

# EG4<sup>®</sup> 18kPV & 12kPV + WALLMOUNT 280Ah ALL WEATHER

## ESS USER MANUAL

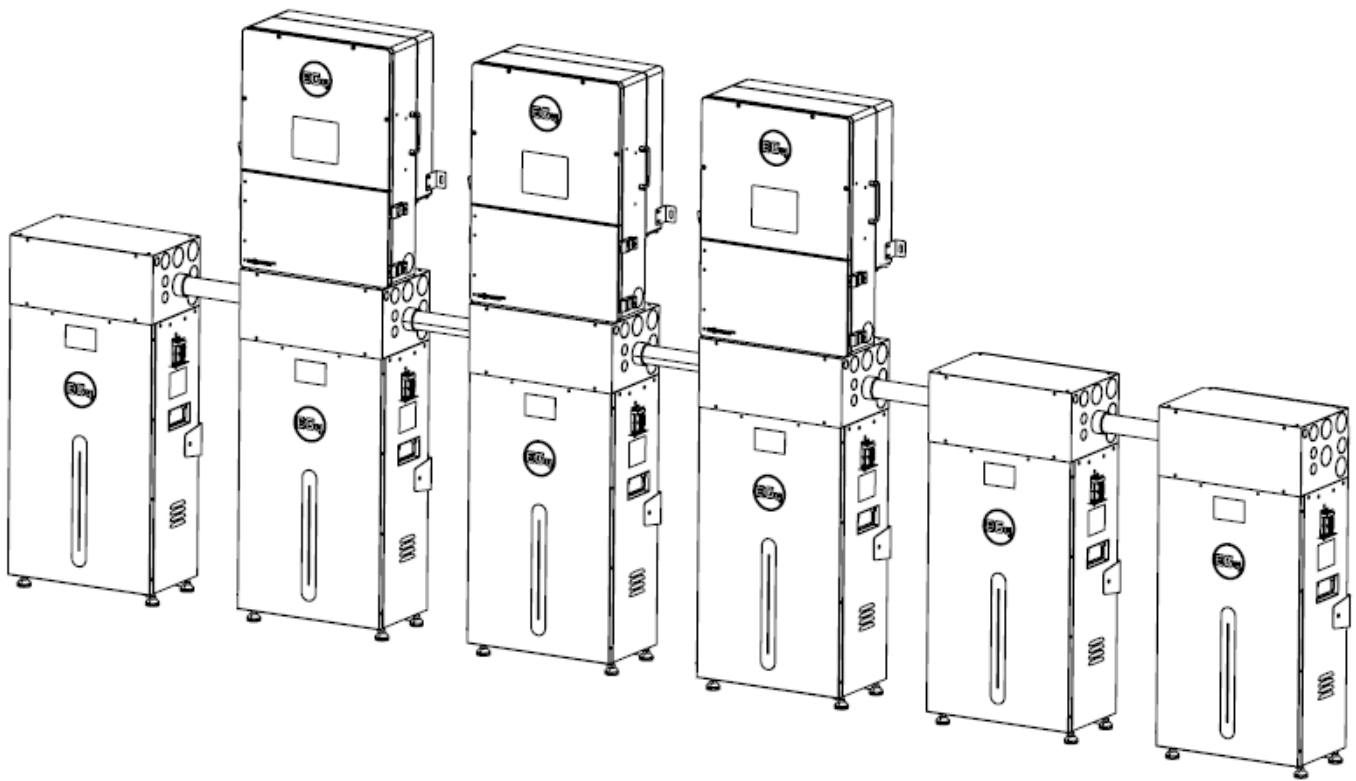

## TABLE OF CONTENTS

1.	TECHNICAL SPECIFICATIONS.....	1
1.1	18KPV ESS TECHNICAL SPECIFICATIONS .....	1
1.2	12KPV ESS TECHNICAL SPECIFICATIONS.....	13
2.	ABBREVIATIONS .....	25
3.	SAFETY.....	26
3.1	SYMBOLS USED IN MANUAL .....	26
3.2	SAFETY INSTRUCTIONS & NOTIFICATIONS.....	27
4.	SÉCURITÉ.....	29
4.1	SYMBOLS UTILISÉS DANS LE MANUEL .....	29
4.2	CONSIGNES DE SÉCURITÉ ET AVIS.....	30
5.	ESS OVERVIEW.....	36
6.	WALLMOUNT AW 280AH INTRODUCTION .....	37
6.1	BATTERY FEATURES.....	37
6.2	BATTERY OVERVIEW.....	38
6.3	BATTERY DIAGRAM .....	39
6.4	PACKING LIST .....	40
7.	12KPV HYBRID INVERTER INTRODUCTION .....	41
7.1	INVERTER OVERVIEW .....	42
7.2	PACKING LIST .....	43
8.	18KPV HYBRID INVERTER INTRODUCTION .....	44
8.1	INVERTER OVERVIEW .....	45
8.2	PACKING LIST .....	48
9.	LOCATION SELECTION & INSTALLATION TOOLS .....	49
9.1	RECOMMENDED TOOLS .....	49
9.2	INSTALLATION LOCATION INFORMATION .....	50
9.3	X-BRACKET OVERVIEW.....	52
9.4	INSTALLING THE BATTERY.....	53
9.5	INSTALLING THE CONDUIT BOX (OPTIONAL) .....	54
9.6	WITH EG4® 18KPV INVERTER .....	55
9.7	WITH EG4® 12KPV INVERTER .....	59
9.8	INSTALLING THE 18KPV INVERTER.....	63
9.9	INSTALLING THE 12KPV INVERTER.....	66
9.10	ORIENTATION EXAMPLE.....	67
10.	PRE-WIRE STEPS & WIRING (BATT, PV, AC) .....	68
10.1	18KPV WIRE SIZING .....	68
10.2	12KPV WIRE SIZING .....	69
10.3	18KPV AND 12KPV RSD/ESS DISCONNECT .....	70
10.4	WALLMOUNT AW 280AH EMERGENCY STOP (RSD, ESS DISCONNECT).....	72
10.5	BATTERY/INVERTER CONNECTION .....	73
10.6	BATTERY CONNECTION.....	74
10.7	MULTIPLE INVERTER PARALLEL INSTALL.....	75
10.8	MULTIPLE BATTERY PARALLEL INSTALL .....	77
10.9	BMS COMMUNICATIONS.....	78
10.10	DIP SWITCH ID TABLE.....	79
11.	WALLMOUNT 280AH AW LCD SCREEN .....	80
11.1	COMMUNICATION PROTOCOL SELECTION .....	81
12.	EG4® MONITOR CENTER .....	83

12.1	EXISTING USER ACCOUNT.....	84
12.2	ENABLE APP NOTIFICATIONS.....	85
12.3	LOCAL MONITORING SETUP WITH THE EG4® MONITORING APP.....	87
13.	DONGLE INSTALLATION.....	88
13.1	CONNECTIVITY REQUIREMENTS.....	88
13.2	DONGLE PARAMETERS.....	89
13.3	LED INDICATORS AND BUTTON FUNCTIONALITY.....	90
13.4	DONGLE BOOTUP STEPS.....	91
14.	ESS STARTUP & SHUTDOWN.....	91
15.	INVERTER WORKING MODES.....	93
15.1	18KPV MODES.....	93
15.2	12KPV MODES.....	101
16.	ESS MAINTENANCE.....	105
16.1	BATTERY END OF LIFE.....	106
16.2	UPDATE DONGLE FIRMWARE USING APP.....	106
16.3	NETWORK SECURITY.....	107
17.	ESS TROUBLESHOOTING.....	111
17.1	18KPV AND 12KPV STATUS CODES.....	111
17.2	FAULT DEFINITIONS & TROUBLESHOOTING.....	112
17.3	ALARM DEFINITIONS & TROUBLESHOOTING.....	114
17.4	BATTERY ALARM DESCRIPTION AND TROUBLESHOOTING.....	116
17.5	TROUBLESHOOTING DONGLE NETWORK CONNECTION.....	118
18.	WARRANTY INFORMATION.....	119

# 1. TECHNICAL SPECIFICATIONS

## 1.1 18KPV ESS TECHNICAL SPECIFICATIONS

18kPV + 1 – 3 280Ah All Weather Batteries

MODEL	PP-48-280A1-18K1-AW-*	PP-48-280A2-18K1-AW-*	PP-48-280A3-18K1-AW-*
<b>BATTERY DATA</b>			
BATTERY TYPE		LiFePo4	
TOTAL ENERGY	14.336kWh	28.672kWh	43.008kWh
BATTERY VOLTAGE RANGE		44.8 – 56 VDC	
NOMINAL VOLTAGE		51.2 VDC	
MAX. CHARGE CURRENT	100A	200A	250A
MAX. DISCHARGE CURRENT	140A	250A	250A
TOTAL CAPACITY	280Ah	560Ah	840Ah
PARALLEL NUMBER	1S1P	1S2P	1S3P
<b>PV INPUT DATA</b>			
MAX. INPUT VOLTAGE		600 VDC	
PV INPUT VOLTAGE RANGE		120 – 500 VDC	
MAX. INPUT CONTINUOUS CURRENT		25/15/15A	
MAX. SHORT-CIRCUIT CURRENT		31/19/19A	
<b>AC INPUT/OUTPUT FOR GRID</b>			
INPUT VOLTAGE		240/208 VAC	
MAX. INPUT/OUTPUT CURRENT		50A	
MAX. SHORT-CIRCUIT CURRENT		156A peak @100us, per inverter	
NOMINAL INPUT/OUTPUT POWER		12kW @240 VAC 10.4kW @208 VAC	
MAX. OUTPUT APPARENT POWER		12kVA @240 VAC 10.4kVA @208 VAC	
MAX. OUTPUT OVER CURRENT PROTECTION		63A per inverter	
OUTPUT POWER FACTOR RATING		0.8 Leading to 0.8 Lagging	
FREQUENCY		60Hz	

**AC OUTPUT FOR OFF-GRID**

NOMINAL VOLTAGE	208 VAC, 120/240 VAC Split-Phase
MAX. CONTINUOUS CURRENT	50A @240/208 VAC
MAX. POWER	12kW @240 VAC 10.4kW @208 VAC
FREQUENCY	60Hz
OUTPUT POWER FACTOR RATING	0.8 Leading to 0.8 Lagging

**GENERAL DATA**

CHARGING TEMPERATURE RANGE	32°F – 131°F (0°C – 55°C)
DISCHARGING TEMPERATURE RANGE	14°F – 131°F (-10°C – 55°C)
INSTALL LOCATION	Battery IP65, Inverter NEMA 4X, Outdoor & Indoor Use, Residential Non-Habitable Spaces
INPUT SHORT-CIRCUIT CURRENT RATING	10kA

## 18kPV + 4 – 6 280Ah All Weather Batteries

MODEL	PP-48-280A4-18K1-AW-*	PP-48-280A5-18K1-AW-*	PP-48-280A6-18K1-AW-*
<b>BATTERY DATA</b>			
BATTERY TYPE		LiFePo4	
TOTAL ENERGY	57.344kWh	71.68kWh	86.016kWh
BATTERY VOLTAGE RANGE		44.8 – 56 VDC	
NOMINAL VOLTAGE		51.2 VDC	
MAX. CHARGE CURRENT	250A	250A	250A
MAX. DISCHARGE CURRENT	250A	250A	250A
TOTAL CAPACITY	1120Ah	1400Ah	1680Ah
PARALLEL NUMBER	1S4P	1S5P	1S6P
<b>PV INPUT DATA</b>			
MAX. INPUT VOLTAGE		600 VDC	
PV INPUT VOLTAGE RANGE		120 – 500 VDC	
MAX. INPUT CONTINUOUS CURRENT		25/15/15A	
MAX. SHORT-CIRCUIT CURRENT		31/19/19A	
<b>AC INPUT/OUTPUT FOR GRID</b>			
INPUT VOLTAGE		240/208 VAC	
MAX. INPUT/OUTPUT CURRENT		50A	
MAX. SHORT-CIRCUIT CURRENT		156A peak @100us, per inverter	
NOMINAL INPUT/OUTPUT POWER		12kW @240 VAC 10.4kW @208 VAC	
MAX. OUTPUT APPARENT POWER		12kVA @240 VAC 10.4kVA @208 VAC	
MAX. OUTPUT OVER CURRENT PROTECTION		63A per inverter	
OUTPUT POWER FACTOR RATING		0.8 Leading to 0.8 Lagging	
FREQUENCY		60Hz	

<b>AC OUTPUT FOR OFF-GRID</b>	
NOMINAL VOLTAGE	208 VAC, 120/240 VAC split-phase
MAX. CONTINUOUS CURRENT	50A @240/208 VAC
MAX. POWER	12kW @240 VAC 10.4kW @208 VAC
FREQUENCY	60Hz
OUTPUT POWER FACTOR RATING	0.8 Leading to 0.8 Lagging
<b>GENERAL DATA</b>	
CHARGING TEMPERATURE RANGE	32°F – 131°F (0°C – 55°C)
DISCHARGING TEMPERATURE RANGE	14°F – 131°F (-10°C – 55°C)
INSTALL LOCATION	Battery IP65, Inverter NEMA 4X, Outdoor & Indoor Use, Residential Non-Habitable Spaces
INPUT SHORT-CIRCUIT CURRENT RATING	10kA

## 18kPV x 2 + 2 – 4 280Ah All Weather Batteries

MODEL	PP-48-280A2-18K2-AW-*	PP-48-280A3-18K2-AW-*	PP-48-280A4-18K2-AW-*
<b>BATTERY DATA</b>			
BATTERY TYPE		LiFePo4	
TOTAL ENERGY	28.672kWh	43.008kWh	57.344kWh
BATTERY VOLTAGE RANGE		44.8 – 56 VDC	
NOMINAL VOLTAGE		51.2 VDC	
MAX. CHARGE CURRENT	200A	300A	400A
MAX. DISCHARGE CURRENT	280A	420A	500A
TOTAL CAPACITY	560Ah	840Ah	1120Ah
PARALLEL NUMBER	1S2P	1S3P	1S4P
<b>PV INPUT DATA</b>			
MAX. INPUT VOLTAGE		600 VDC	
PV INPUT VOLTAGE RANGE		120 – 500 VDC	
MAX. INPUT CONTINUOUS CURRENT		25/15/15A per inverter	
MAX. SHORT-CIRCUIT CURRENT		31/19/19A per inverter	
<b>AC INPUT/OUTPUT FOR GRID</b>			
INPUT VOLTAGE		240/208 VAC	
MAX. INPUT/OUTPUT CURRENT		100A	
MAX. SHORT-CIRCUIT CURRENT		156A peak @100us, per inverter	
NOMINAL INPUT/OUTPUT POWER		24kW @240 VAC 20.8kW @208 VAC	
MAX. OUTPUT APPARENT POWER		24kVA @240 VAC 20.8kVA @208 VAC	
MAX. OUTPUT OVER CURRENT PROTECTION		63A per inverter	
OUTPUT POWER FACTOR RATING		0.8 Leading to 0.8 Lagging	
FREQUENCY		60Hz	

**AC OUTPUT FOR OFF-GRID**

NOMINAL VOLTAGE	208 VAC, 120/240 VAC split-phase
MAX. CONTINUOUS CURRENT	100A @240/208 VAC
MAX. POWER	24kW @240 VAC 20.8kW @208 VAC
FREQUENCY	60Hz
OUTPUT POWER FACTOR RATING	0.8 Leading to 0.8 Lagging

**GENERAL DATA**

CHARGING TEMPERATURE RANGE	32°F – 131°F (0°C – 55°C)
DISCHARGING TEMPERATURE RANGE	14°F – 131°F (-10°C – 55°C)
INSTALL LOCATION	Battery IP65, Inverter NEMA 4X, Outdoor & Indoor Use, Residential Non-Habitable Spaces
INPUT SHORT-CIRCUIT CURRENT RATING	10kA

## 18kPV x 2 + 5 – 6 280Ah All Weather Batteries

MODEL	PP-48-280A5-18K2-AW-*	PP-48-280A6-18K2-AW-*
<b>BATTERY DATA</b>		
BATTERY TYPE	LiFePo4	
TOTAL ENERGY	71.68kWh	86.016kWh
BATTERY VOLTAGE RANGE	44.8 – 56 VDC	
NOMINAL VOLTAGE	51.2 VDC	
MAX. CHARGE CURRENT	500A	500A
MAX. DISCHARGE CURRENT	500A	500A
TOTAL CAPACITY	1400Ah	1680Ah
PARALLEL NUMBER	1S5P	1S6P
<b>PV INPUT DATA</b>		
MAX. INPUT VOLTAGE	600 VDC	
PV INPUT VOLTAGE RANGE	120 – 500 VDC	
MAX. INPUT CONTINUOUS CURRENT	25/15/15A per inverter	
MAX. SHORT-CIRCUIT CURRENT	31/19/19A per inverter	
<b>AC INPUT/OUTPUT FOR GRID</b>		
INPUT VOLTAGE	240/208 VAC	
MAX. INPUT/OUTPUT CURRENT	100A	
MAX. SHORT-CIRCUIT CURRENT	156A peak @100us, per inverter	
NOMINAL INPUT/OUTPUT POWER	24kW @240 VAC 20.8kW @208 VAC	
MAX. OUTPUT APPARENT POWER	24kVA @240 VAC 20.8kVA @208 VAC	
MAX. OUTPUT OVER CURRENT PROTECTION	63A per inverter	
OUTPUT POWER FACTOR RATING	0.8 Leading to 0.8 Lagging	
FREQUENCY	60Hz	

<b>AC OUTPUT FOR OFF-GRID</b>	
NOMINAL VOLTAGE	208 VAC, 120/240 VAC Split-Phase
MAX. CONTINUOUS CURRENT	100A @240/208 VAC
MAX. POWER	24kW @240 VAC 20.8kW @208 VAC
FREQUENCY	60Hz
OUTPUT POWER FACTOR RATING	0.8 Leading to 0.8 Lagging
<b>GENERAL DATA</b>	
CHARGING TEMPERATURE RANGE	32°F – 131°F (0°C – 55°C)
DISCHARGING TEMPERATURE RANGE	14°F – 131°F (-10°C – 55°C)
INSTALL LOCATION	Battery IP65, Inverter NEMA 4X, Outdoor & Indoor Use, Residential Non-Habitable Spaces
INPUT SHORT-CIRCUIT CURRENT RATING	10kA

## 18kPV x 3 + 3 – 4 280Ah All Weather Batteries

MODEL	PP-48-280A3-18K3-AW-*	PP-48-280A4-18K3-AW-*
<b>BATTERY DATA</b>		
BATTERY TYPE	LiFePo4	
TOTAL ENERGY	43.008kWh	57.344kWh
BATTERY VOLTAGE RANGE	44.8 – 56 VDC	
NOMINAL VOLTAGE	51.2 VDC	
MAX. CHARGE CURRENT	300A	400A
MAX. DISCHARGE CURRENT	420A	560A
TOTAL CAPACITY	840Ah	1120Ah
PARALLEL NUMBER	1S3P	1S4P
<b>PV INPUT DATA</b>		
MAX. INPUT VOLTAGE	600 VDC	
PV INPUT VOLTAGE RANGE	120 – 500 VDC	
MAX. INPUT CONTINUOUS CURRENT	25/15/15A per inverter	
MAX. SHORT-CIRCUIT CURRENT	31/19/19A per inverter	
<b>AC INPUT/OUTPUT FOR GRID</b>		
INPUT VOLTAGE	240/208 VAC	
MAX. INPUT/OUTPUT CURRENT	150A	
MAX. SHORT-CIRCUIT CURRENT	156A peak @100us, per inverter	
NOMINAL INPUT/OUTPUT POWER	36kW @240 VAC 31.2kW @208 VAC	
MAX. OUTPUT APPARENT POWER	36kVA @240 VAC 31.2kVA @208 VAC	
MAX. OUTPUT OVER CURRENT PROTECTION	63A per inverter	
OUTPUT POWER FACTOR RATING	0.8 Leading to 0.8 Lagging	
FREQUENCY	60Hz	

**AC OUTPUT FOR OFF-GRID**

NOMINAL VOLTAGE	208 VAC, 120/240 VAC Split-Phase
MAX. CONTINUOUS CURRENT	150A @240/208 VAC
MAX. POWER	36kW @240 VAC 31.2kW @208 VAC
FREQUENCY	60Hz
OUTPUT POWER FACTOR RATING	0.8 Leading to 0.8 Lagging

**GENERAL DATA**

CHARGING TEMPERATURE RANGE	32°F – 131°F (0°C – 55°C)
DISCHARGING TEMPERATURE RANGE	14°F – 131°F (-10°C – 55°C)
INSTALL LOCATION	Battery IP65, Inverter NEMA 4X, Outdoor & Indoor Use, Residential Non-Habitable Spaces
INPUT SHORT-CIRCUIT CURRENT RATING	10kA

## 18kPV x 3 + 5 – 6 280Ah All Weather Batteries

MODEL	PP-48-280A5-18K3-AW-*	PP-48-280A6-18K3-AW-*
<b>BATTERY DATA</b>		
BATTERY TYPE	LiFePo4	
TOTAL ENERGY	71.68kWh	86.016kWh
BATTERY VOLTAGE RANGE	44.8 – 56 VDC	
NOMINAL VOLTAGE	51.2 VDC	
MAX. CHARGE CURRENT	500A	600A
MAX. DISCHARGE CURRENT	700A	750A
TOTAL CAPACITY	1400Ah	1680Ah
PARALLEL NUMBER	1S5P	1S6P
<b>PV INPUT DATA</b>		
MAX. INPUT VOLTAGE	600 VDC	
PV INPUT VOLTAGE RANGE	120 – 500 VDC	
MAX. INPUT CONTINUOUS CURRENT	25/15/15A per inverter	
MAX. SHORT-CIRCUIT CURRENT	31/19/19A per inverter	
<b>AC INPUT/OUTPUT FOR GRID</b>		
INPUT VOLTAGE	240/208 VAC	
MAX. INPUT/OUTPUT CURRENT	150A	
MAX. SHORT-CIRCUIT CURRENT	156A peak @100us, per inverter	
NOMINAL INPUT/OUTPUT POWER	36kW @240 VAC 31.2kW @208 VAC	
MAX. OUTPUT APPARENT POWER	36kVA @240 VAC 31.2kVA @208 VAC	
MAX. OUTPUT OVER CURRENT PROTECTION	63A per inverter	
OUTPUT POWER FACTOR RATING	0.8 Leading to 0.8 Lagging	
FREQUENCY	60Hz	

**AC OUTPUT FOR OFF-GRID**

NOMINAL VOLTAGE	208 VAC, 120/240 VAC Split-Phase
MAX. CONTINUOUS CURRENT	150A @240/208 VAC
MAX. POWER	36kW @240 VAC 31.2kW @208 VAC
FREQUENCY	60Hz
OUTPUT POWER FACTOR RATING	0.8 Leading to 0.8 Lagging

**GENERAL DATA**

CHARGING TEMPERATURE RANGE	32°F – 131°F (0°C – 55°C)
DISCHARGING TEMPERATURE RANGE	14°F – 131°F (-10°C – 55°C)
INSTALL LOCATION	Battery IP65, Inverter NEMA 4X, Outdoor & Indoor Use, Residential Non-Habitable Spaces
INPUT SHORT-CIRCUIT CURRENT RATING	10kA

## 1.2 12KPV ESS TECHNICAL SPECIFICATIONS

12kPV + 1 – 3 280Ah All Weather Batteries

MODEL	PP-48-280A1-12K1-AW-*	PP-48-280A2-12K1-AW-*	PP-48-280A3-12K1-AW-*
<b>BATTERY DATA</b>			
BATTERY TYPE		LiFePo4	
TOTAL ENERGY	14.336kWh	28.672kWh	43.008kWh
BATTERY VOLTAGE RANGE		44.8 – 56 VDC	
NOMINAL VOLTAGE		51.2 VDC	
MAX. CHARGE CURRENT	100A	167A	167A
MAX. DISCHARGE CURRENT	140A	167A	167A
TOTAL CAPACITY	280Ah	560Ah	840Ah
PARALLEL NUMBER	1S1P	1S2P	1S3P
<b>PV INPUT DATA</b>			
MAX. INPUT VOLTAGE		600 VDC	
PV INPUT VOLTAGE RANGE		120 – 500 VDC	
MAX. INPUT CONTINUOUS CURRENT		25/25A	
MAX. SHORT-CIRCUIT CURRENT		31/31A	
<b>AC INPUT/OUTPUT FOR GRID</b>			
INPUT VOLTAGE		240/208 VAC	
MAX. INPUT/OUTPUT CURRENT		33.3A @240 VAC 38.5A @208 VAC	
MAX. SHORT-CIRCUIT CURRENT		160A peak @440us, per inverter	
NOMINAL INPUT/OUTPUT POWER		8kW @240 VAC 8kW @208 VAC	
MAX. OUTPUT APPARENT POWER		8kVA @240 VAC 8kVA @208 VAC	
MAX. OUTPUT OVER CURRENT PROTECTION		63A or 80A per inverter	
OUTPUT POWER FACTOR RATING		0.8 Leading to 0.8 Lagging	
FREQUENCY		60Hz	

**AC OUTPUT FOR OFF-GRID**

NOMINAL VOLTAGE	208 VAC, 120/240 VAC Split-Phase
MAX. CONTINUOUS CURRENT	33.3A @240 VAC
	38.5A @208 VAC
MAX. POWER	8kW @240 VAC
	8kW @208 VAC
FREQUENCY	60Hz
OUTPUT POWER FACTOR RATING	0.8 Leading to 0.8 Lagging

**GENERAL DATA**

CHARGING TEMPERATURE RANGE	32°F – 131°F (0°C – 55°C)
DISCHARGING TEMPERATURE RANGE	14°F – 131°F (-10°C – 55°C)
INSTALL LOCATION	Battery IP65, Inverter NEMA 4X, Outdoor & Indoor Use, Residential Non-Habitable Spaces
INPUT SHORT-CIRCUIT CURRENT RATING	10kA

## 12kPV + 4 – 6 280Ah All Weather Batteries

MODEL	PP-48-280A4-12K1-AW-*	PP-48-280A5-12K1-AW-*	PP-48-280A6-12K1-AW-*
<b>BATTERY DATA</b>			
BATTERY TYPE		LiFePo4	
TOTAL ENERGY	57.344kWh	71.68kWh	86.016kWh
BATTERY VOLTAGE RANGE		44.8 – 56 VDC	
NOMINAL VOLTAGE		51.2 VDC	
MAX. CHARGE CURRENT	167A	167A	167A
MAX. DISCHARGE CURRENT	167A	167A	167A
TOTAL CAPACITY	1120Ah	1400Ah	1680Ah
PARALLEL NUMBER	1S4P	1S5P	1S6P
<b>PV INPUT DATA</b>			
MAX. INPUT VOLTAGE		600 VDC	
PV INPUT VOLTAGE RANGE		120 – 500 VDC	
MAX. INPUT CONTINUOUS CURRENT		25/25A	
MAX. SHORT-CIRCUIT CURRENT		31/31A	
<b>AC INPUT/OUTPUT FOR GRID</b>			
INPUT VOLTAGE		240/208 VAC	
MAX. INPUT/OUTPUT CURRENT		33.3A @240 VAC 38.5A @208 VAC	
MAX. SHORT-CIRCUIT CURRENT		160A peak @440us, per inverter	
NOMINAL INPUT/OUTPUT POWER		8kW @240 VAC 8kW @208 VAC	
MAX. OUTPUT APPARENT POWER		8kVA @240 VAC 8kVA @208 VAC	
MAX. OUTPUT OVER CURRENT PROTECTION		63A or 80A per inverter	
OUTPUT POWER FACTOR RATING		0.8 Leading to 0.8 Lagging	
FREQUENCY		60Hz	

**AC OUTPUT FOR OFF-GRID**

NOMINAL VOLTAGE	208 VAC, 120/240 VAC Split-Phase
MAX. CONTINUOUS CURRENT	33.3A @240 VAC 38.5A @208 VAC
MAX. POWER	8kW @240 VAC 8kW @208 VAC
FREQUENCY	60Hz
OUTPUT POWER FACTOR RATING	0.8 Leading to 0.8 Lagging

**GENERAL DATA**

CHARGING TEMPERATURE RANGE	32°F – 131°F (0°C – 55°C)
DISCHARGING TEMPERATURE RANGE	14°F – 131°F (-10°C – 55°C)
INSTALL LOCATION	Battery IP65, Inverter NEMA 4X, Outdoor & Indoor Use, Residential Non-Habitable Spaces
INPUT SHORT-CIRCUIT CURRENT RATING	10kA

## 12kPV x 2 + 2 – 4 280Ah All Weather Batteries

MODEL	PP-48-280A2-12K2-AW-*	PP-48-280A3-12K2-AW-*	PP-48-280A4-12K2-AW-*
<b>BATTERY DATA</b>			
BATTERY TYPE		LiFePo4	
TOTAL ENERGY	28.672kWh	43.008kWh	57.344kWh
BATTERY VOLTAGE RANGE		44.8 – 56 VDC	
NOMINAL VOLTAGE		51.2 VDC	
MAX. CHARGE CURRENT	200A	300A	334A
MAX. DISCHARGE CURRENT	280A	334A	334A
TOTAL CAPACITY	560Ah	840Ah	1120Ah
PARALLEL NUMBER	1S2P	1S3P	1S4P
<b>PV INPUT DATA</b>			
MAX. INPUT VOLTAGE		600 VDC	
PV INPUT VOLTAGE RANGE		120 – 500 VDC	
MAX. INPUT CONTINUOUS CURRENT		25/25A per inverter	
MAX. SHORT-CIRCUIT CURRENT		31/31A per inverter	
<b>AC INPUT/OUTPUT FOR GRID</b>			
INPUT VOLTAGE		240/208 VAC	
MAX. INPUT/OUTPUT CURRENT		66.6A @240 VAC 77A @208 VAC	
MAX. SHORT-CIRCUIT CURRENT		160A peak @440us, per inverter	
NOMINAL INPUT/OUTPUT POWER		16kW @240 VAC 16kW @208 VAC	
MAX. OUTPUT APPARENT POWER		16kVA @240 VAC 16kVA @208 VAC	
MAX. OUTPUT OVER CURRENT PROTECTION		63A or 80A per inverter	
OUTPUT POWER FACTOR RATING		0.8 Leading to 0.8 Lagging	
FREQUENCY		60Hz	

**AC OUTPUT FOR OFF-GRID**

NOMINAL VOLTAGE	208 VAC, 120/240 VAC Split-Phase
MAX. CONTINUOUS CURRENT	66.6A @240 VAC 77A @208 VAC
MAX. POWER	16kW @240 VAC 16kW @208 VAC
FREQUENCY	60Hz
OUTPUT POWER FACTOR RATING	0.8 Leading to 0.8 Lagging

**GENERAL DATA**

CHARGING TEMPERATURE RANGE	32°F – 131°F (0°C – 55°C)
DISCHARGING TEMPERATURE RANGE	14°F – 131°F (-10°C – 55°C)
INSTALL LOCATION	Battery IP65, Inverter NEMA 4X, Outdoor & Indoor Use, Residential Non-Habitable Spaces
INPUT SHORT-CIRCUIT CURRENT RATING	10kA

## 12kPV x 2 + 5 – 6 280Ah All Weather Batteries

MODEL	PP-48-280A5-12K2-AW-*	PP-48-280A6-12K2-AW-*
<b>BATTERY DATA</b>		
BATTERY TYPE	LiFePo4	
TOTAL ENERGY	71.68kWh	86.016kWh
BATTERY VOLTAGE RANGE	44.8 – 56 VDC	
NOMINAL VOLTAGE	51.2 VDC	
MAX. CHARGE CURRENT	334A	334A
MAX. DISCHARGE CURRENT	334A	334A
TOTAL CAPACITY	1400Ah	1680Ah
PARALLEL NUMBER	1S5P	1S6P
<b>PV INPUT DATA</b>		
MAX. INPUT VOLTAGE	600 VDC	
PV INPUT VOLTAGE RANGE	120 – 500 VDC	
MAX. INPUT CONTINUOUS CURRENT	25/25A per inverter	
MAX. SHORT-CIRCUIT CURRENT	31/31A per inverter	
<b>AC INPUT/OUTPUT FOR GRID</b>		
INPUT VOLTAGE	240/208 VAC	
MAX. INPUT/OUTPUT CURRENT	66.6A @240 VAC 77A @208 VAC	
MAX. SHORT-CIRCUIT CURRENT	160A peak @440us, per inverter	
NOMINAL INPUT/OUTPUT POWER	16kW @240 VAC 16kW @208 VAC	
MAX. OUTPUT APPARENT POWER	16kVA @240 VAC 16kVA @208 VAC	
MAX. OUTPUT OVER CURRENT PROTECTION	63A or 80A per inverter	
OUTPUT POWER FACTOR RATING	0.8 Leading to 0.8 Lagging	
FREQUENCY	60Hz	

**AC OUTPUT FOR OFF-GRID**

NOMINAL VOLTAGE	208 VAC, 120/240 VAC Split-Phase
MAX. CONTINUOUS CURRENT	66.6A @240 VAC 77A @208 VAC
MAX. POWER	16kW @240 VAC 16kW @208 VAC
FREQUENCY	60Hz
OUTPUT POWER FACTOR RATING	0.8 Leading to 0.8 Lagging

**GENERAL DATA**

CHARGING TEMPERATURE RANGE	32°F – 131°F (0°C – 55°C)
DISCHARGING TEMPERATURE RANGE	14°F – 131°F (-10°C – 55°C)
INSTALL LOCATION	Battery IP65, Inverter NEMA 4X, Outdoor & Indoor Use, Residential Non-Habitable Spaces
INPUT SHORT-CIRCUIT CURRENT RATING	10kA

## 12kPV x 3 + 3 – 4 280Ah All Weather Batteries

MODEL	PP-48-280A3-12K3-AW-*	PP-48-280A4-12K3-AW-*
<b>BATTERY DATA</b>		
BATTERY TYPE	LiFePo4	
TOTAL ENERGY	43.008kWh	57.344kWh
BATTERY VOLTAGE RANGE	44.8 – 56 VDC	
NOMINAL VOLTAGE	51.2 VDC	
MAX. CHARGE CURRENT	300A	400A
MAX. DISCHARGE CURRENT	420A	501A
TOTAL CAPACITY	840Ah	1120Ah
PARALLEL NUMBER	1S3P	1S4P
<b>PV INPUT DATA</b>		
MAX. INPUT VOLTAGE	600 VDC	
PV INPUT VOLTAGE RANGE	120 – 500 VDC	
MAX. INPUT CONTINUOUS CURRENT	25/25A per inverter	
MAX. SHORT-CIRCUIT CURRENT	31/31A per inverter	
<b>AC INPUT/OUTPUT FOR GRID</b>		
INPUT VOLTAGE	240/208 VAC	
MAX. INPUT/OUTPUT CURRENT	99.9A @240 VAC 115.5A @208 VAC	
MAX. SHORT-CIRCUIT CURRENT	160A peak @440us, per inverter	
NOMINAL INPUT/OUTPUT POWER	24kW @240 VAC 24kW @208 VAC	
MAX. OUTPUT APPARENT POWER	24kVA @240 VAC 24kVA @208 VAC	
MAX. OUTPUT OVER CURRENT PROTECTION	63A or 80A per inverter	
OUTPUT POWER FACTOR RATING	0.8 Leading to 0.8 Lagging	
FREQUENCY	60Hz	

**AC OUTPUT FOR OFF-GRID**

NOMINAL VOLTAGE	208 VAC, 120/240 VAC Split-Phase
MAX. CONTINUOUS CURRENT	99.9A @240 VAC
	115.5A @208 VAC
MAX. POWER	24kW @240 VAC
	24kW @208 VAC
FREQUENCY	60Hz
OUTPUT POWER FACTOR RATING	0.8 Leading to 0.8 Lagging

**GENERAL DATA**

CHARGING TEMPERATURE RANGE	32°F – 131°F (0°C – 55°C)
DISCHARGING TEMPERATURE RANGE	14°F – 131°F (-10°C – 55°C)
INSTALL LOCATION	Battery IP65, Inverter NEMA 4X, Outdoor & Indoor Use, Residential Non-Habitable Spaces
INPUT SHORT-CIRCUIT CURRENT RATING	10kA

## 12kPV x 3 + 5 – 6 280Ah All Weather Batteries

MODEL	PP-48-280A3-12K3-AW-*	PP-48-280A4-12K3-AW-*
<b>BATTERY DATA</b>		
BATTERY TYPE	LiFePo4	
TOTAL ENERGY	71.68kWh	86.016kWh
BATTERY VOLTAGE RANGE	44.8 – 56 VDC	
NOMINAL VOLTAGE	51.2 VDC	
MAX. CHARGE CURRENT	500A	501A
MAX. DISCHARGE CURRENT	501A	501A
TOTAL CAPACITY	840Ah	1120Ah
PARALLEL NUMBER	1S5P	1S6P
<b>PV INPUT DATA</b>		
MAX. INPUT VOLTAGE	600 VDC	
PV INPUT VOLTAGE RANGE	120 – 500 VDC	
MAX. INPUT CONTINUOUS CURRENT	25/25A per inverter	
MAX. SHORT-CIRCUIT CURRENT	31/31A per inverter	
<b>AC INPUT/OUTPUT FOR GRID</b>		
INPUT VOLTAGE	240/208 VAC	
MAX. INPUT/OUTPUT CURRENT	99.9A @240 VAC 115.5A @208 VAC	
MAX. SHORT-CIRCUIT CURRENT	160A peak @440us, per inverter	
NOMINAL INPUT/OUTPUT POWER	24kW @240 VAC 24kW @208 VAC	
MAX. OUTPUT APPARENT POWER	24kVA @240 VAC 24kVA @208 VAC	
MAX. OUTPUT OVER CURRENT PROTECTION	63A or 80A per inverter	
OUTPUT POWER FACTOR RATING	0.8 Leading to 0.8 Lagging	
FREQUENCY	60Hz	

**AC OUTPUT FOR OFF-GRID**

NOMINAL VOLTAGE	208 VAC, 120/240 VAC Split-Phase
MAX. CONTINUOUS CURRENT	99.9A @240 VAC 115.5A @208 VAC
MAX. POWER	24kW @240 VAC 24kW @208 VAC
FREQUENCY	60Hz
OUTPUT POWER FACTOR RATING	0.8 Leading to 0.8 Lagging

**GENERAL DATA**

CHARGING TEMPERATURE RANGE	32°F – 131°F (0°C – 55°C)
DISCHARGING TEMPERATURE RANGE	14°F – 131°F (-10°C – 55°C)
INSTALL LOCATION	Battery IP65, Inverter NEMA 4X, Outdoor & Indoor Use, Residential Non-Habitable Spaces
INPUT SHORT-CIRCUIT CURRENT RATING	10kA

## 2. ABBREVIATIONS

- AWG – American Wire Gauge
- A – Amps
- Ah – Amp hour(s)
- AC – Alternating Current
- AFCI – Arc-Fault Circuit Interrupter
- AHJ – Authority Having Jurisdiction
- kAIC – kilo-Amp Interrupting Capability
- ANSI – American National Standards Institute
- BAT – Battery
- BMS – Battery Management System
- COM – Communication
- CT – Current Transformer
- DC – Direct Current
- DIP – Dual In-line Package
- DOD – Depth of Discharge
- EG – Equipment Ground
- EGS – Equipment Grounding System
- EMC – Electromagnetic Compatibility
- EPS – Emergency Power System
- ESS – Energy Storage System
- E-Stop – Emergency Stop
- FCC – Federal Communication Commission
- GE – Grounding Electrode
- GEC – Grounding Electrode Conductor
- GFCI – Ground Fault Circuit Interrupter
- GFDI – Ground Fault Detector/Interrupter
- Imp – Maximum Power Point Current
- IEEE – Institute of Electrical and Electronic Engineers
- IP – Ingress Protection
- I<sub>sc</sub> – Short-Circuit Current
- In-lbs. – Inch Pounds
- kW – Kilowatt
- kWh – Kilowatt-hour
- LCD – Liquid Crystal Display
- LFP – Lithium Iron Phosphate
- L1 – Line 1
- L2 – Line 2
- mm – Millimeters
- MPPT – Maximum Power Point Tracking
- mV – Millivolt
- N – Neutral
- NEC – National Electric Code
- NEMA – National Electrical Manufacturers Association
- NFPA – National Fire Prevention Association
- Nm – Newton Meters
- NOCT – Normal Operating Cell Temperature
- PC – Personal Computer
- PCB – Printed Circuit Board
- PE – Protective Earth
- PPE – Personal Protective Equipment
- PV – Photovoltaic
- RSD – Rapid Shut Down
- SCC – Standards Council of Canada
- SOC – State of Charge
- STC – Standard Testing Conditions
- UL – Underwriters Laboratories
- UPS – Uninterrupted Power Supply
- V – Volts
- VOC – Open-Circuit Voltage
- VMP – Voltage Maximum Power

## 3. SAFETY

### 3.1 SYMBOLS USED IN MANUAL



This type of notation indicates a severe hazard that presents an immediate risk of serious injury or death.



This type of notation indicates that a hazard may pose a risk to human health and safety



Use team lift whenever load weight, size, or center of gravity exceeds safe single-person handling limits. Coordinated lifting improves stability, control, and significantly reduces injury risk.



This type of notation indicates that the hazard could potentially damage the equipment.



This type of notation indicates that the information provided is important for the installation, operation, and/or maintenance of the equipment. Failure to follow the recommendations in such a notation could result in the equipment warranty being voided.



This type of notation indicates useful information.

### SYMBOLS USED ON EQUIPMENT

	<p><b>WARNING:</b> Read the instructions before installation, operation, and maintenance of the system.</p>
	<p><b>WARNING:</b> Read the instructions before installation, operation, and maintenance of the system.</p>
	<p><b>WARNING:</b> Hazardous Voltage Circuits!</p>

## 3.2 SAFETY INSTRUCTIONS & NOTIFICATIONS

EG4® inverters, batteries, and system components are designed and tested in strict adherence to international safety standards. Before beginning any work, carefully review all safety instructions and follow them throughout the handling of all system components. Installation should be performed only by qualified service personnel who must adhere to the guidelines provided and follow appropriate practices in accordance with local electrical, building, fire, and utility regulations. It is also essential to consult the local Authority Having Jurisdiction (AHJ) to obtain any necessary permits and approvals prior to installation.

### Incorrect installation may cause:

- Injury or death to the installer, operator, or third party
- Damage to the inverter or other attached equipment



### WARNING

**All tasks related to this product**, including system design, installation, operation, setup, configuration, and maintenance, must be performed by trained personnel. To prevent electric shock, avoid performing any maintenance beyond what is outlined in the operating instructions unless qualified to do so.



### DANGER

**Hazardous Voltage Circuits!** There are various safety concerns that must be carefully observed before, during, and after installation, as well as during future operation and maintenance. The following are important safety notifications for the installer and any end users of this product under normal operating conditions.

**Save these instructions. This manual contains instructions for the 18kPV, the 12kPV, and the WallMount 280Ah All Weather battery which shall be followed during the installation and maintenance of the inverter and battery.**

1. **Beware of high PV voltage.** Install an external DC disconnect switch or breaker, making sure it is in the “off” or “open” position before installing or working on the inverter. Use a voltmeter to verify that no DC voltage is present to prevent electric shock.
2. **Beware of high grid voltage.** Confirm the AC switch and/or AC breaker are in the “off” or “open” position before installing or working on the inverter. Use a voltmeter to confirm that no voltage is present to prevent electric shock.
3. **Beware of high battery current.** Confirm the battery module breakers and/or on/off switches are in the “open” or “off” position before installing or working on the inverter. Use a voltmeter to confirm that no DC voltage is present to avoid electric shock.
4. **Do not open the inverter cable connection area while it is operating to avoid electric shock and damage from live voltage and current within the system.**
5. **Do not make any connections or disconnections (PV, battery, grid, communication, etc.) while the system is operating.** Damage to system components or risk of elec shock may occur if working with energized batteries.
6. **The system uses DC current.** DC current can lead to sustained muscle contractions, severe burns, or fire if mishandled during electric shock incidents.
7. **Do not disassemble the inverter or battery.** Contact the distributor for any issues requiring repair, for more information, and for proper handling instructions. Incorrect servicing or reassembly may pose a risk of electric shock or fire and void the warranty.
8. Ensure the PV, battery, and grid connections are secure and proper to prevent damage or injuries caused by improper installation.

9. Damage to the equipment or improper installation may cause arc flash, which can result in serious damage, injury, or death.
10. Make sure the inverter and battery are properly grounded.
11. Read all instructions before commencing installation. For electrical work, follow all local and national wiring standards, regulations, and these installation instructions. All wiring should comply with the National Electrical Code (NEC), ANSI/NFPA 70.
12. The inverter can connect to the utility grid only if the utility provider permits. Consult the local AHJ (Authority Having Jurisdiction) before installing this product to confirm any additional regulations or requirements for the immediate area.
13. All warning labels and nameplates on system components (inverters, batteries, etc.) must be clearly visible and must not be removed or covered.
14. The installer should consider the safety of future users when choosing the correct position and location of the inverter and battery, as specified in this manual.
15. Keep children from touching or misusing the inverter, battery, and relevant system components.
16. **Beware!** The inverter and other components of the system can get hot during use. Do not touch the inverter's surface or other components while the system is operating. During operation, only the LCD (if equipped) and buttons should be touched.
17. Rupture of the battery and shorting of battery cells can cause the release of toxic gases and harmful electrolyte solutions.
18. The installer must be adequately protected by wearing suitable, professional insulation gear, such as Personal Protective Equipment (PPE).
19. Some system components can be very heavy. Be sure to use team lift and other safe lifting techniques throughout the installation.
20. Before installing, operating, or maintaining any components in the system, it is important to inspect all existing wiring to ensure it meets the appropriate specifications and operating conditions.



## WARNING

Cancer and reproductive harm – See [www.p65warnings.ca.gov](http://www.p65warnings.ca.gov) for more details.

---

### DISCLAIMER

EG4 reserves the right to make changes to the material herein at any time without notice. Please refer to [www.eg4electronics.com](http://www.eg4electronics.com) for the most updated version of our manuals/spec sheets.

## 4. SÉCURITÉ

### 4.1 SYMBOLES UTILISÉS DANS LE MANUEL

#### DANGER

Ce type de signalisation indique un danger grave présentant un risque immédiat de blessures graves, voire mortelles.

#### AVERTISSEMENT

Ce type de signalisation indique qu'un danger peut présenter un risque pour la santé et la sécurité humaines.

#### LEVAGE EN ÉQUIPE

Utilisez le levage à deux personnes lorsque le poids, les dimensions ou le centre de gravité de la charge dépassent les limites de manutention sécuritaire pour une seule personne. Un levage coordonné améliore la stabilité et le contrôle, et réduit considérablement les risques de blessure.

#### REMARQUER

Ce type de notation indique que les informations fournies sont importantes pour l'installation, le fonctionnement et/ou l'entretien de l'équipement. Le non-respect des recommandations figurant dans cette notation pourrait entraîner l'annulation de la garantie de l'équipement.



#### RAPPEL

Ce type de notation indique des informations précédemment mentionnées qui doivent être prises en compte pour garantir un fonctionnement et une sécurité optimaux.

#### NOTE

Ce type de notation indique des informations utiles.

### SYMBOLES UTILISÉS SUR L'ÉQUIPEMENT

	<b>AVERTISSEMENT :</b> Lisez les instructions avant l'installation, l'utilisation et l'entretien du système.
	<b>AVERTISSEMENT :</b> Lisez les instructions avant l'installation, l'utilisation et l'entretien du système.
	<b>AVERTISSEMENT :</b> Circuits à tension dangereuse.

## 4.2 CONSIGNES DE SÉCURITÉ ET AVIS

Les onduleurs, batteries et composants système EG4® sont conçus et testés en stricte conformité avec les normes de sécurité internationales. Avant toute intervention, veuillez lire attentivement toutes les consignes de sécurité et les respecter scrupuleusement lors de la manipulation du système. L'installation doit être effectuée uniquement par du personnel qualifié, qui doit respecter les directives fournies et appliquer les bonnes pratiques conformément aux réglementations locales en matière d'électricité, de construction, de sécurité incendie et de services publics. Il est également essentiel de consulter l'autorité compétente locale afin d'obtenir les permis et autorisations nécessaires avant l'installation.

### Une installation incorrecte peut entraîner les effets suivants :

- Blessure ou décès de l'installateur, de l'exploitant ou d'un tiers
- Dommages à la batterie ou à tout autre équipement attaché



### AVERTISSEMENT

**Pour réduire le risque de blessure, lisez toutes les instructions !** Toutes les tâches relatives à ce produit, y compris la conception du système, l'installation, le fonctionnement, la configuration et la maintenance, doivent être effectuées par du personnel qualifié. Afin de prévenir tout risque d'électrocution, il est impératif de ne procéder à aucune opération de maintenance autre que celles décrites dans le manuel d'utilisation, sauf si vous possédez les qualifications requises.



### DANGER

**Circuits à haute tension!** Il existe diverses précautions de sécurité qui doivent être scrupuleusement respectées avant, pendant et après l'installation, ainsi que lors de l'utilisation et de la maintenance futures. Vous trouverez ci-dessous des consignes de sécurité importantes destinées à l'installateur et à tout utilisateur final de ce produit dans des conditions normales d'utilisation.

**Conservez ces Instructions. Ce manuel contient des instructions importantes concernant les modèles 18kPV, 12kPV et la batterie en tout temps WallMount 280Ah, qui doivent être suivies lors de l'installation et de l'entretien de l'onduleur et de la batterie.**

1. **Méfiez-vous des tensions photovoltaïques élevées.** Installez un sectionneur ou un disjoncteur CC externe et assurez-vous qu'il est en position « off » ou « open » avant d'installer ou de travailler sur l'onduleur. Utilisez un voltmètre pour vérifier l'absence de tension CC afin d'éviter tout risque d'électrocution.
2. **Méfiez-vous des tensions élevées du réseau.** Assurez-vous que l'interrupteur CA et/ou le disjoncteur CA sont en position « off » ou « open » avant d'installer ou de travailler sur l'onduleur. Utilisez un voltmètre pour vérifier qu'il n'y a pas de tension afin d'éviter tout risque d'électrocution.
3. **Méfiez-vous du courant élevé de la batterie.** Assurez-vous que les disjoncteurs du module de batterie et/ou les interrupteurs marche/arrêt sont en position « ouverte » ou « arrêt » avant d'installer ou de travailler sur l'onduleur. Utilisez un voltmètre pour vérifier qu'il n'y a pas de tension continue afin d'éviter tout risque d'électrocution.
4. **N'ouvrez pas la zone de connexion des câbles de l'onduleur pendant son fonctionnement afin d'éviter tout risque d'électrocution et tout dommage causé par la tension et le courant présents dans le système.**
5. **N'effectuez aucune connexion ou déconnexion (PV, batterie, réseau, communication, etc.) pendant que le système est en fonctionnement.** Des dommages aux composants du système ou un risque de choc électrique peuvent survenir si vous travaillez avec des batteries sous tension.

6. Le système utilise du courant continu. Le courant continu peut entraîner des contractions musculaires prolongées, des brûlures graves ou un incendie s'il est mal manipulé lors d'incidents de choc électrique.
7. Ne démontez pas l'onduleur ou la batterie. Contactez le distributeur pour tout problème nécessitant une réparation, pour plus d'informations et pour obtenir des instructions de manipulation appropriées. Un entretien ou un remontage incorrect peut présenter un risque d'électrocution ou d'incendie et annuler la garantie.
8. Assurez-vous que les connexions PV, batterie et réseau sont sécurisées et correctes afin d'éviter tout dommage ou blessure causé par une installation incorrecte.
9. Tout dommage causé à l'ESS ou toute installation incorrecte peut provoquer un arc électrique, pouvant entraîner des dommages graves, des blessures ou la mort.
10. Assurez-vous que l'onduleur et la batterie sont correctement mis à la terre.
11. Lisez toutes les instructions avant de commencer l'installation. Pour les travaux électriques, respectez toutes les normes et réglementations locales et nationales en matière de câblage, ainsi que les présentes instructions d'installation. Tout le câblage doit être conforme au Code national de l'électricité (NEC), ANSI/NFPA 70.
12. L'onduleur et le système ne peuvent être interconnectés avec le réseau électrique public que si le fournisseur d'électricité l'autorise. Consultez l'autorité compétente locale avant d'installer ce produit afin de confirmer toute réglementation ou exigence supplémentaire applicable à la zone immédiate.
13. Toutes les étiquettes d'avertissement et plaques signalétiques apposées sur les composants du système (onduleurs, batteries, etc.) doivent être clairement visibles et ne doivent pas être retirées ou recouvertes.
14. L'installateur doit tenir compte de la sécurité des futurs utilisateurs lorsqu'il choisit la position et l'emplacement corrects de l'onduleur et de la batterie, comme indiqué dans ce manuel.
15. Empêchez les enfants de toucher ou d'utiliser de manière abusive l'onduleur, la batterie et les composants du système concernés.
16. **Attention !** L'onduleur et certaines parties du système peuvent devenir chauds pendant leur utilisation. Ne touchez pas la surface de l'onduleur ni la plupart de ses composants lorsque le système est en marche. Pendant le fonctionnement, seuls l'écran LCD (si présent) et les boutons doivent être touchés.
17. La rupture de la batterie et le court-circuit des cellules de la batterie peuvent entraîner le dégagement de gaz toxiques et de solutions électrolytiques nocives.
18. L'installateur doit s'assurer qu'il est correctement protégé en portant un équipement d'isolation professionnel adapté, tel qu'un équipement de protection individuelle (EPI).
19. Certains composants du système peuvent être très lourds. Veillez à utiliser des techniques de levage en équipe et d'autres techniques de levage sécuritaires tout au long de l'installation.
20. Avant d'installer, d'utiliser ou d'entretenir tout composant du système, il est important d'inspecter tout le câblage existant afin de s'assurer qu'il répond aux spécifications et aux conditions de fonctionnement appropriées.



## AVERTISSEMENT

Cancer et dommages reproductifs – Voir [www.P654warnings.ca.gov](http://www.P654warnings.ca.gov) pour plus de détails.

## DISCLAIMER

EG4® se réserve le droit de modifier le contenu de ce document à tout moment sans préavis. Veuillez consulter [www.eg4electronics.com](http://www.eg4electronics.com) pour la version la plus récente de nos manuels/fiches techniques.



## TAKE THESE ADDITIONAL PRECAUTIONS DURING INSTALLATION/REPLACEMENT

**Ensure that all precautions listed above have been taken prior to beginning the installation and observe these additional precautions during installation. Failure to take these precautions may result in serious injury or death:**



- **Thermal Runaway:** Immediately stop the installation, place battery in a safe state if possible, and move away from the battery if the battery:
  - begins to swell or bulge,
  - if you smell any unusual odors,
  - if you hear a hissing sound, or
  - if the battery begins to emit heat and/or smoke.

**Your battery may be experiencing thermal runaway, a dangerous condition that may cause fire or explosion. Contact local fire department, Chemtrec 800-262-8200, and EG4 support.**



- **Electrical Shock:** When installing/replacing the battery:
  - Ensure that the battery does not get wet.
  - Do not spray water or other liquids on the battery.
  - Do not perform the installation in conditions where dust, moisture, or other debris could enter the battery.
  - Avoid touching connections and components unless instructed to do so by this guide.
  - Do not leave the battery unattended during the installation without it being in a safe state. Do not touch, lean on, or lay tools on the battery or connections.

**If you are electrically shocked during installation, place battery in a safe state if possible, and seek immediate medical attention.**



- **Ventilation Warning:** When installing/replacing the battery:
  - Do not open the battery.
  - Do not attempt the installation/replacement if the battery is damaged.

*Lithium batteries may emit toxic gases when ruptured. Do not attempt to repair the battery in the case of rupture. Move outdoors in the case of rupture and seek professional assistance.*



- **Electrolyte Exposure: When installing/replacing the battery:**
  - *Ensure that the battery is not damaged.*
  - *Do not attempt the installation/replacement if the battery is damaged.*

*Lithium batteries contain a liquid electrolyte solution that is corrosive and damaging to skin and eyes. Exposure may occur in the case of damage to the battery. In the case of contact with skin or eyes, wash continuously with water for 15 minutes and seek immediate medical attention. Remove contaminated clothes immediately. In the case of ingestion, drink at least two glasses of water or milk, induce vomiting if unconscious, and seek immediate medical attention.*

### **General Advice:**

In all cases of exposure, seek medical attention if symptoms persist or if large amounts of electrolyte are involved. Show this safety information to the treating physician.

### **Skin Contact:**

- Immediately remove contaminated clothing and shoes.
- Rinse affected skin thoroughly with plenty of water for at least 15 minutes.
- Seek medical attention if irritation persists or burns appear.
- Wash contaminated clothing before reusing.

### **Eye Contact:**

- Immediately flush eyes with plenty of water for at least 15 minutes, keeping eyelids open.
- Remove contact lenses if present and easy to do.
- Seek immediate medical attention.

### **Inhalation (if applicable):**

- Move the person to fresh air immediately.
- If breathing is difficult, provide oxygen. If not breathing, give artificial respiration.
- Seek immediate medical attention.

### **Ingestion:**

- Do not induce vomiting.
- Rinse mouth with water.
- Give small amounts of water or milk to dilute, if the person is conscious and alert.
- Never give anything by mouth to an unconscious person.
- Seek immediate medical attention or contact Poison Control immediately.



## PRENEZ CES PRÉCAUTIONS SUPPLÉMENTAIRES LORS DE L'INSTALLATION OU DU REMPLACEMENT

Assurez-vous que toutes les précautions énumérées ci-dessus ont été prises avant de commencer l'installation et respectez ces précautions supplémentaires pendant l'installation. Le non-respect de ces précautions peut entraîner des blessures graves ou la mort.



- Emballement thermique: Arrêtez immédiatement l'installation, mettez la batterie dans un état sécuritaire si possible et éloignez-vous de la batterie si celle-ci :
  - commence à gonfler ou à se déformer,
  - dégage des odeurs inhabituelles,
  - émet un sifflement, ou
  - commence à dégager de la chaleur et/ou de la fumée.

La batterie peut être en situation d'emballement thermique, une condition dangereuse pouvant entraîner un incendie ou une explosion. Communiquez avec le service d'incendie local, Chemtrec au 800-262-8200, et le soutien EG4.



- Choc électrique: Lors de l'installation ou du remplacement de la batterie :
  - Assurez-vous que la batterie ne soit pas mouillée.
  - Ne vaporisez pas d'eau ni d'autres liquides sur la batterie.
  - N'effectuez pas l'installation dans des conditions où de la poussière, de l'humidité ou d'autres débris pourraient pénétrer dans la batterie.
  - Évitez de toucher les connexions et les composants sauf indication contraire dans ce guide.
  - Ne laissez pas la batterie sans surveillance pendant l'installation si elle n'est pas dans un état sécuritaire
  - Ne touchez pas la batterie, ne vous appuyez pas dessus et ne déposez pas d'outils sur la batterie ou les connexions.

En cas de choc électrique pendant l'installation, mettez la batterie dans un état sécuritaire si possible et consultez immédiatement un professionnel de la santé.



- Avertissement – Ventilation: Lors de l'installation ou du remplacement de la batterie :
  - N'ouvrez pas la batterie.
  - N'effectuez pas l'installation ou le remplacement si la batterie est endommagée.

*Les batteries au lithium peuvent émettre des gaz toxiques en cas de rupture. N'essayez pas de réparer la batterie si elle est rompue. En cas de rupture, déplacez-vous à l'extérieur et demandez l'assistance d'un professionnel qualifié.*



- **Exposition à l'électrolyte : Lors de l'installation ou du remplacement de la batterie :**
  - *Assurez-vous que la batterie n'est pas endommagée.*
  - *N'effectuez pas l'installation ou le remplacement si la batterie est endommagée.*

*Les batteries au lithium contiennent une solution d'électrolyte liquide corrosive et nocive pour la peau et les yeux. Une exposition peut survenir si la batterie est endommagée. En cas de contact avec la peau ou les yeux, rincez abondamment à l'eau pendant 15 minutes et consultez immédiatement un professionnel de la santé. Retirez immédiatement les vêtements contaminés. En cas d'ingestion, buvez au moins deux verres d'eau ou de lait, provoquez le vomissement si la personne est consciente, et consultez immédiatement un professionnel de la santé.*

### **Conseils généraux :**

Dans tous les cas d'exposition, consultez un médecin si les symptômes persistent ou si de grandes quantités d'électrolytes sont impliquées. Montrez ces informations de sécurité au médecin traitant.

#### **Contact avec la peau :**

- Retirez immédiatement les vêtements et chaussures contaminés.
- Rincez abondamment la peau affectée à l'eau pendant au moins 15 minutes.
- Consultez un médecin si l'irritation persiste ou si des brûlures apparaissent.
- Laver les vêtements contaminés avant de les réutiliser.

#### **Contact avec les yeux :**

- Rincer immédiatement les yeux à grande eau pendant au moins 15 minutes, gardant les paupières ouvertes.
- Retirer les lentilles de contact si présentes et si cela est facile à faire.
- Consulter immédiatement un médecin.

#### **Inhalation (le cas échéant) :**

- Transporter immédiatement la personne à l'air frais.
- Si la respiration est difficile, administrer de l'oxygène. Si la personne ne respire pas, pratiquer la respiration artificielle.
- Consulter immédiatement un médecin

#### **Ingestion :**

- Ne pas faire vomir.
- Rincer la bouche à l'eau.
- Donner de petites quantités d'eau ou de lait pour diluer, si la personne est consciente et alerte.
- Ne jamais rien donner par voie orale à une personne inconsciente.
- Consultez immédiatement un médecin ou contactez immédiatement le centre antipoison.

## 5. ESS OVERVIEW

The UL 9540 certified ESS (Energy Storage System) consists of a maximum configuration of 3 × EG4® 18kPV or 12kPV hybrid inverters and 6 × EG4 WallMount AW 280Ah lithium batteries. The following diagram shows the spacing for 3 × EG4® 18kPV or 12kPV hybrid inverters and 6 × EG4 WallMount AW 280Ah lithium batteries and is for reference only. For more detailed information on installation, scan the following QR codes:



18kPV User Manual



12kPV Quick Start Guide



WallMount Indoor 280Ah  
Quick Start Guide



### NOTE

**Per UL9540**, 3 x EG4 18kPV or 12kPV hybrid inverters with 6 x WallMount 280Ah All Weather is the max. configuration for the ESS.

**For UL9540 compliance**, each ESS must use only one inverter model. **Do not mix** the 12kPV and 18kPV within the same ESS.

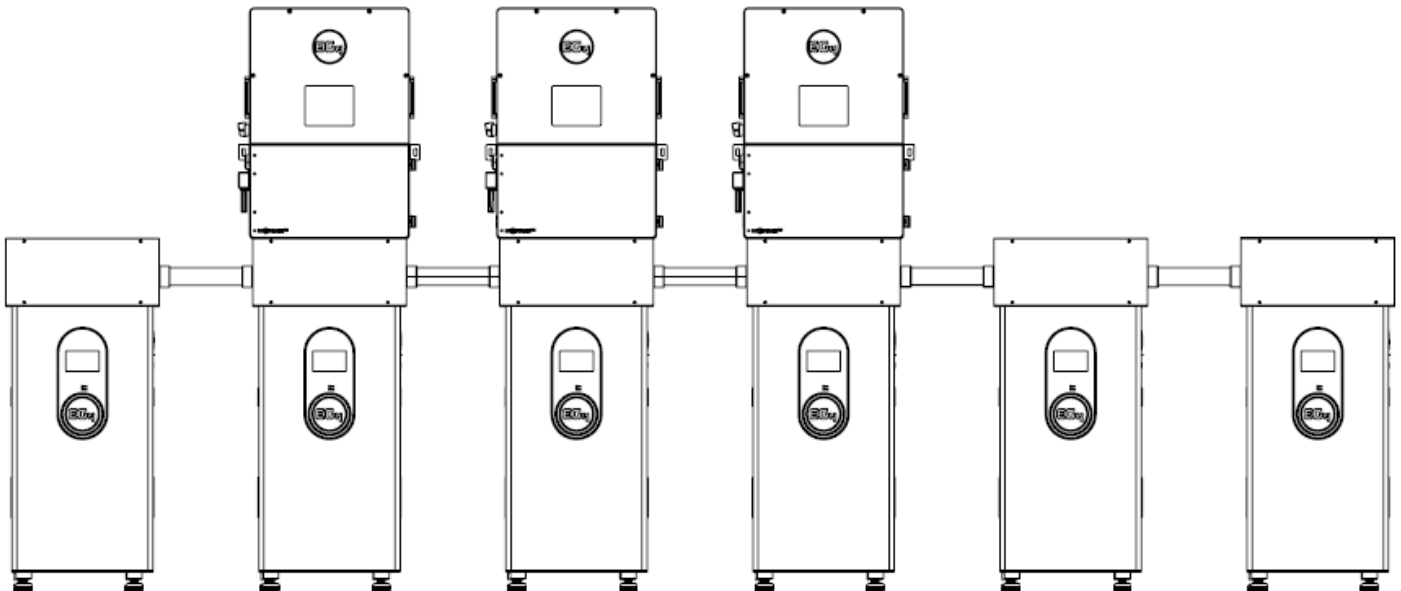

## 6. WALLMOUNT AW 280AH INTRODUCTION

The EG4® 48V WallMount All Weather 280Ah batteries are ideal for low-voltage residential outdoor energy storage system (ESS) applications. These batteries use lithium iron phosphate (LiFePO<sub>4</sub> or LFP) cells with the highest safety performance and an intelligent Battery Management System (BMS) that can monitor and record the voltage of each cell, along with the current, voltage, and temperature of the module in real-time. The BMS also contains a passive balance function and an advanced battery control method, both of which improve the performance of the battery pack. For enhanced security, the battery has two onboard fire-extinguishing modules. With a design life of more than 15 years, the WallMount is designed to last over 8000 cycles at 80% DOD at 0.5C°.



### 6.1 BATTERY FEATURES

- Constant rated output current of 200A
- IP65 all-weather rated, integrated self-heating during low ambient temperatures
- Smart balancing of cells enhancing the battery consistency and the lifespan up to 15 years of life with over 8000 cycles at 80% DOD at 0.5C
- Built-in intelligent BMS with battery voltage, current, temperature, and health management to reduce electrical risks and overheating
- Internal busbars rated to 600 Amps for paralleling multiple batteries and feeding multiple inverters
- Real time monitoring and LCD screen to display battery voltage, current, temperature, SOC in detail
- Integrated E-stop circuit supports emergency stop function with remote Rapid Shutdown Initiator (RSD) or Energy Storage Systems (ESS) disconnect or by inverter's RSD or ESS terminals
- Communicate with inverter using CAN or RS485. Firmware update using RS485
- Plug-and-play cable installation with the use of the 250A weather-tight quick connectors
- Stable, reliable, and maintenance-free battery pack
- Comprehensive safety UL1973 and UL9540A on cell and module level with enhanced onboard fire-extinguishing modules

## 6.2 BATTERY OVERVIEW

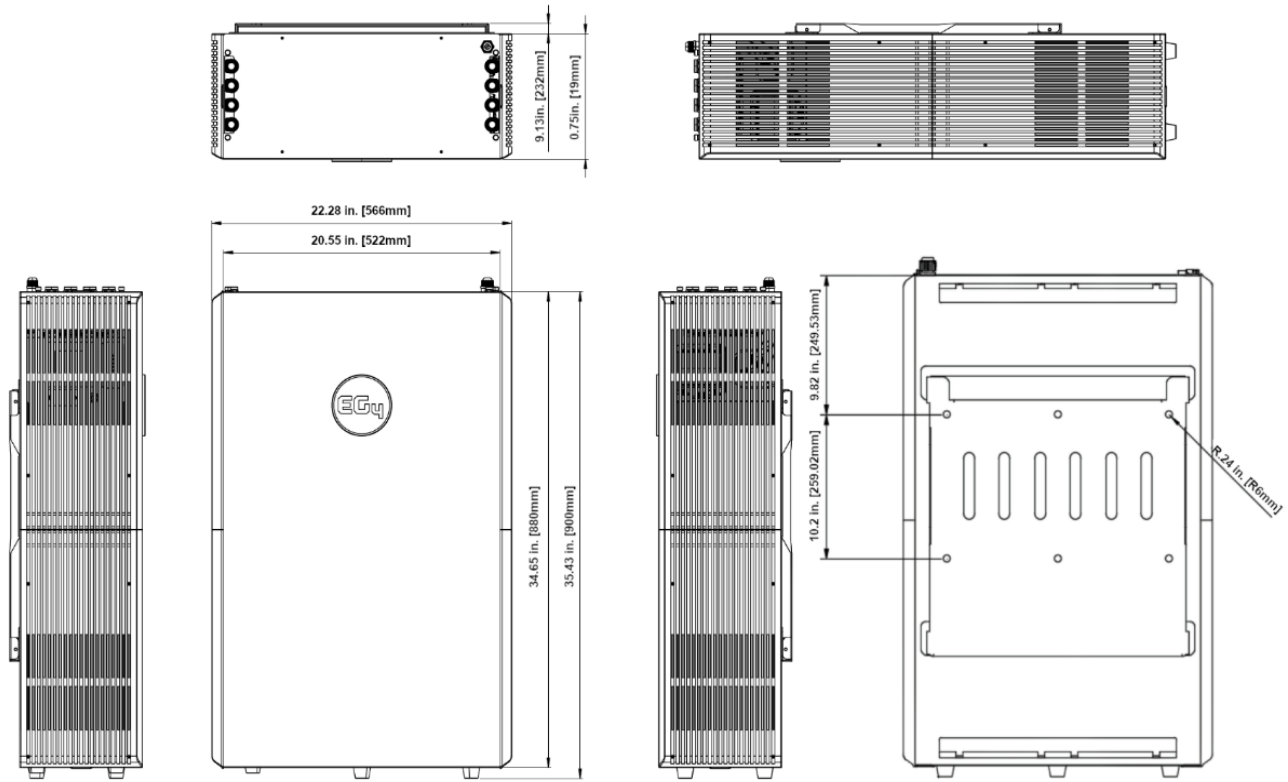

Battery Cross-Sectional View

**! DANGER**

**When installing or removing a battery, verify battery is powered off,** and use a multimeter to confirm there is no voltage present. Failure to do so can result in severe injury and/or death.

## 6.3 BATTERY DIAGRAM

Side Panel  
Screws

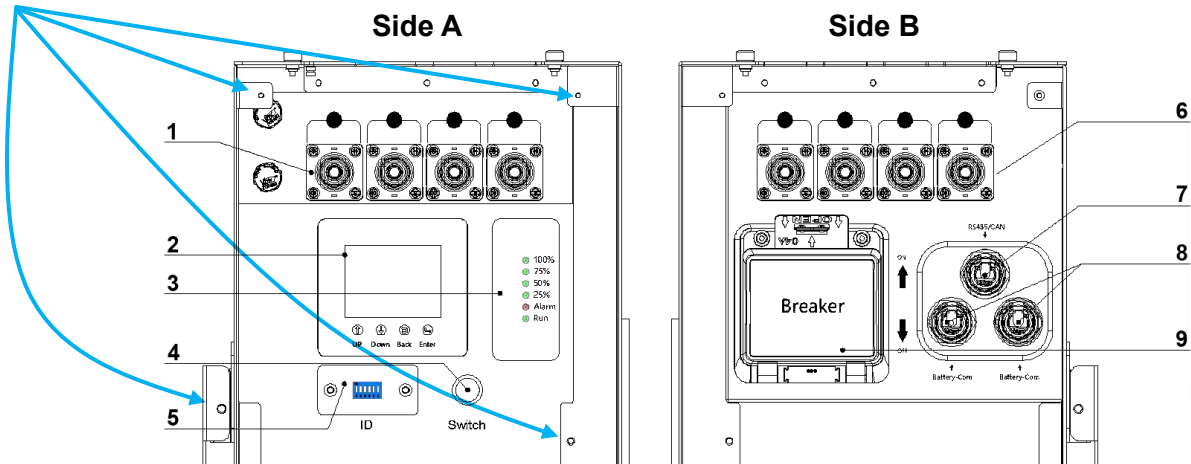

NO.	ITEM	DESCRIPTION	REMARKS
1	Negative Terminals	Connects to negative terminal of Inverter and/or paralleled battery	
2	LCD Screen	Shows battery information	
3	SOC Display	State of Charge LED	
4	Power Switch	Turns BMS on/off	
5	ID/DIP Switch	DIP Switch board for BMS	
6	Positive Terminal	Connects to positive terminal of Inverter and/or paralleled battery	
7	RS485/CAN Port	RS485/CAN Communication Interface	Pin 1 & Pin 8 – RS485_B Pin 2 & Pin 7 – RS485_A Pin 4 – CAN_H Pin 5 – CAN_L
8	Battery-Comm	Parallel battery Communication Port	Pin 1 & Pin 8 – RS485_B Pin 2 & Pin 7 – RS485_A Pin 3 & Pin 6 – E-Stop NO
9	Battery Disconnect Breaker	Turns power supply on/off	Double Pole Single Throw 125 Frame size 125A Rating*



### NOTE

The battery disconnect breaker is 2 single pole breakers with a singular switch, parallel to reach 250A rating.

## 6.4 PACKING LIST

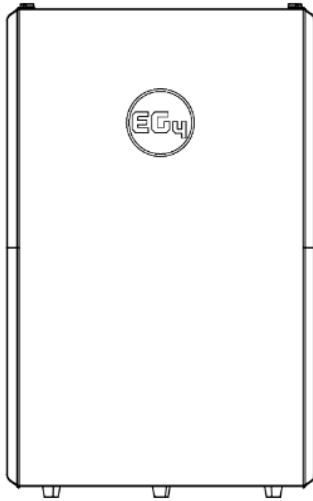

**280Ah All Weather  
(Qty 1)**

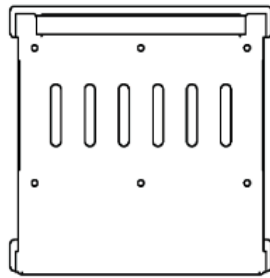

**Mounting bracket (Qty 1)**

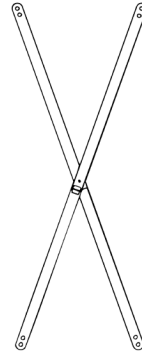

**X-Bracket**

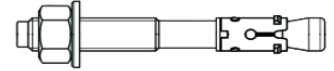

**Concrete expansion bolts  
M8×70 (Qty 6)**

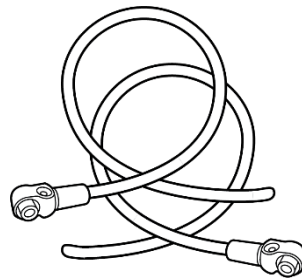

**Black power cable 2/0 AWG 39.4 in.  
(to inverter negative terminal) (Qty 2)**

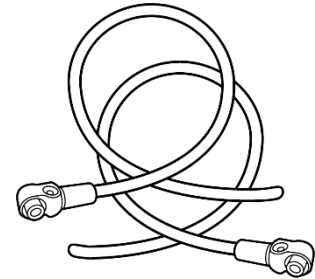

**Red power cable 2/0 AWG 39.4 in. (to  
inverter positive terminal) (Qty 2)**

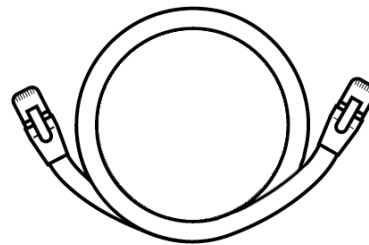

**Battery to Inverter  
communication cable (Qty 1)**

## 7. 12KPV HYBRID INVERTER INTRODUCTION



The EG4<sup>®</sup> 12kPV is a 48V split-phase hybrid inverter designed for energy independence, ideal for both rural and suburban homeowners. Sharing architecture and firmware with the EG4 18kPV, it powers loads while charging batteries but stands out with a more compact design, simpler installation, and lower cost. Integrating MPPTs, DC-AC inversion, grid interaction, and battery connectivity, it eliminates the need for extra charge controllers or transformers. With 12kW PV input and 8kW continuous output, it's a powerful, modular, and expandable solution. Remote monitoring and updates via the EG4 Web App ensure convenience and control.

## 7.1 INVERTER OVERVIEW

### Back View of the Cable Box Knockouts

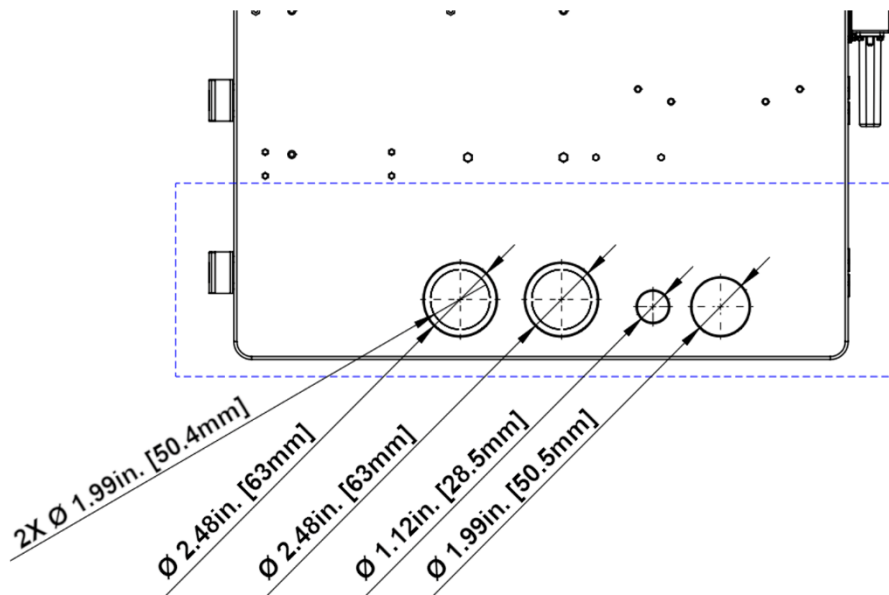

### Bottom View of Cable Box Knockouts

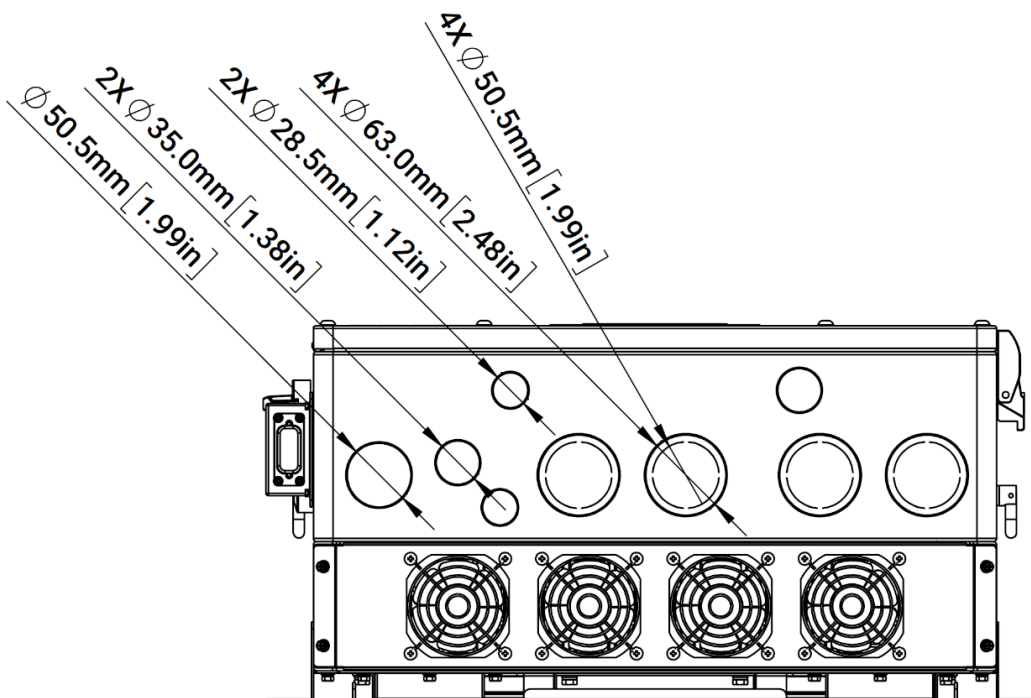







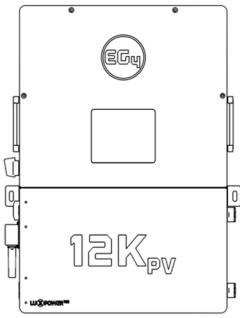
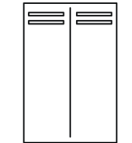

U.S. NOM. TRADE SIZE	ACTUAL KNOCKOUT SIZE
1/2 in.	0.88 in. (22.2 mm)
3/4 in.	1.12 in. (28.5 mm)
1 in.	1.38 in. (35 mm)
1 1/4 in.	1.73 in. (44 mm)
1 1/2 in.	1.99 in. (50.5 mm)
2 in.	2.48 in. (63 mm)

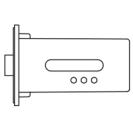
## 7.2 PACKING LIST

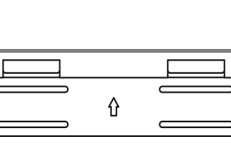
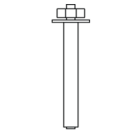
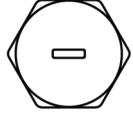
The items listed below will arrive with each product shipment:

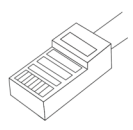
### 12kPV:

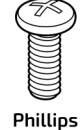
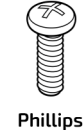
 <p>Hybrid Inverter ×1</p>	 <p>Paperboard ×1</p>	 <p>1" CT ×2</p>	 <p>Wi-Fi Dongle ×1</p>	 <p>6ft. Battery Comm Cable (Orange) ×1</p>	 <p>6ft. Parallel Comm Cable (Grey) ×1</p>	 <p>Wall Mounting Bracket ×1</p>	
 <p>Expansion Bolts ×6</p>	 <p>Assorted Knockout Plugs</p>	 <p>L-Bracket ×2</p>	 <p>RJ 45 ×4</p>	 <p>Keys ×2</p>	 <p>Phillips Head Screw (M5) ×4</p>	 <p>Phillips Head Screw (M3) ×4</p>	

## 8. 18KPV HYBRID INVERTER INTRODUCTION



The EG4<sup>®</sup> 18kPV is a 48V split-phase hybrid inverter designed for rural and suburban homeowners seeking energy independence. This flagship inverter stands as a testament to complete energy independence with the ability to power loads while simultaneously charging batteries. Users can harness multiple power sources, including photovoltaic (PV), battery storage, as well as the grid. Additionally, the 18kPV features a comprehensive list of certifications that ensure code compliance while offering additional safety and reliability.

## 8.1 INVERTER OVERVIEW

Breaker selection recommendation for both DC and AC:

Label	Breaker/Switch	Description
A	PV Input	See section 1 for specs
B	Integrated Bonded Battery Breaker	200A × 2
C	Integrated Bonded Load Breaker	L1: 200A L2: 200A
D	AC Input/Output	See section 1 for specs
E	Generator	240VAC/100A

Overview of the Cable Box

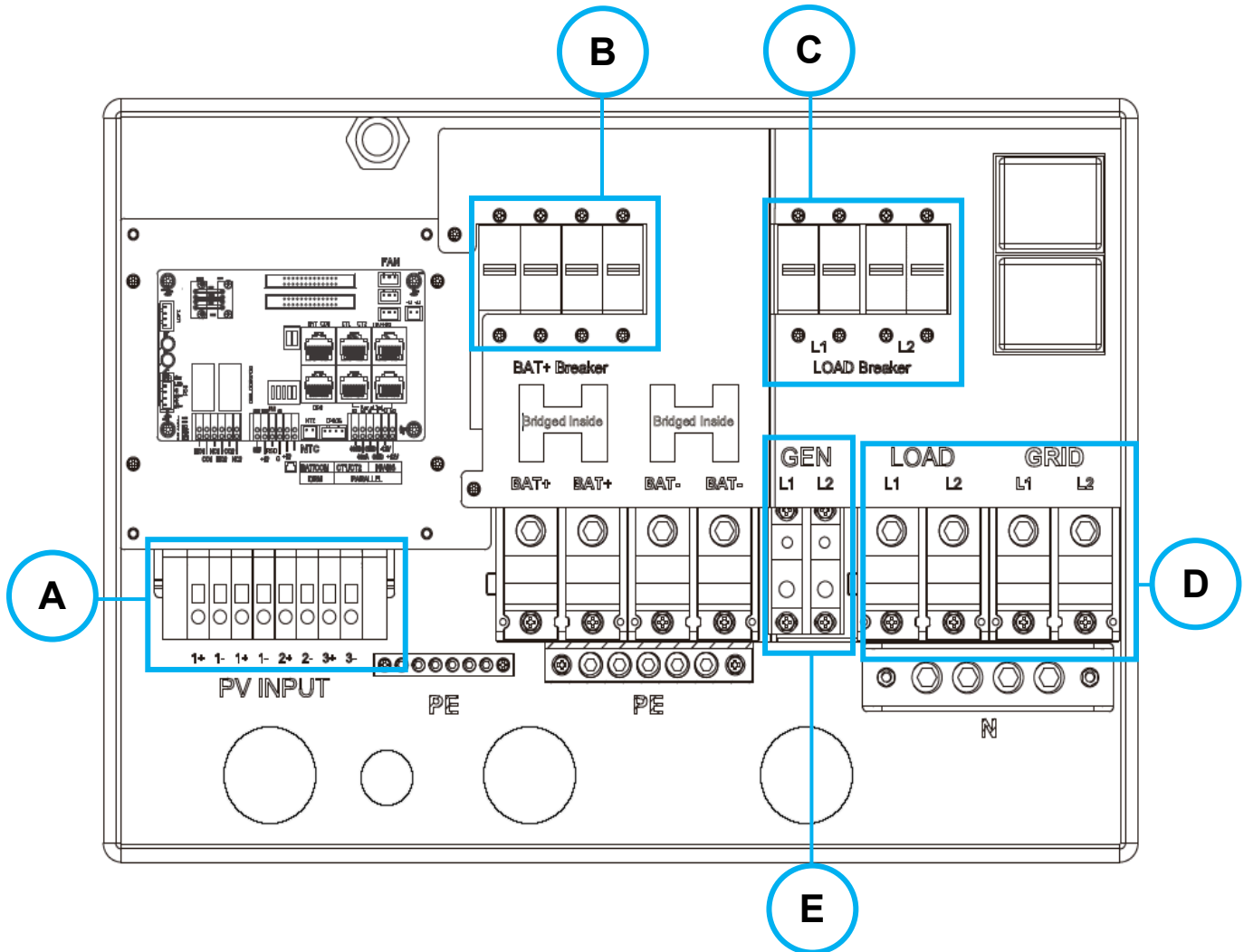

## Overview of Connection Ports

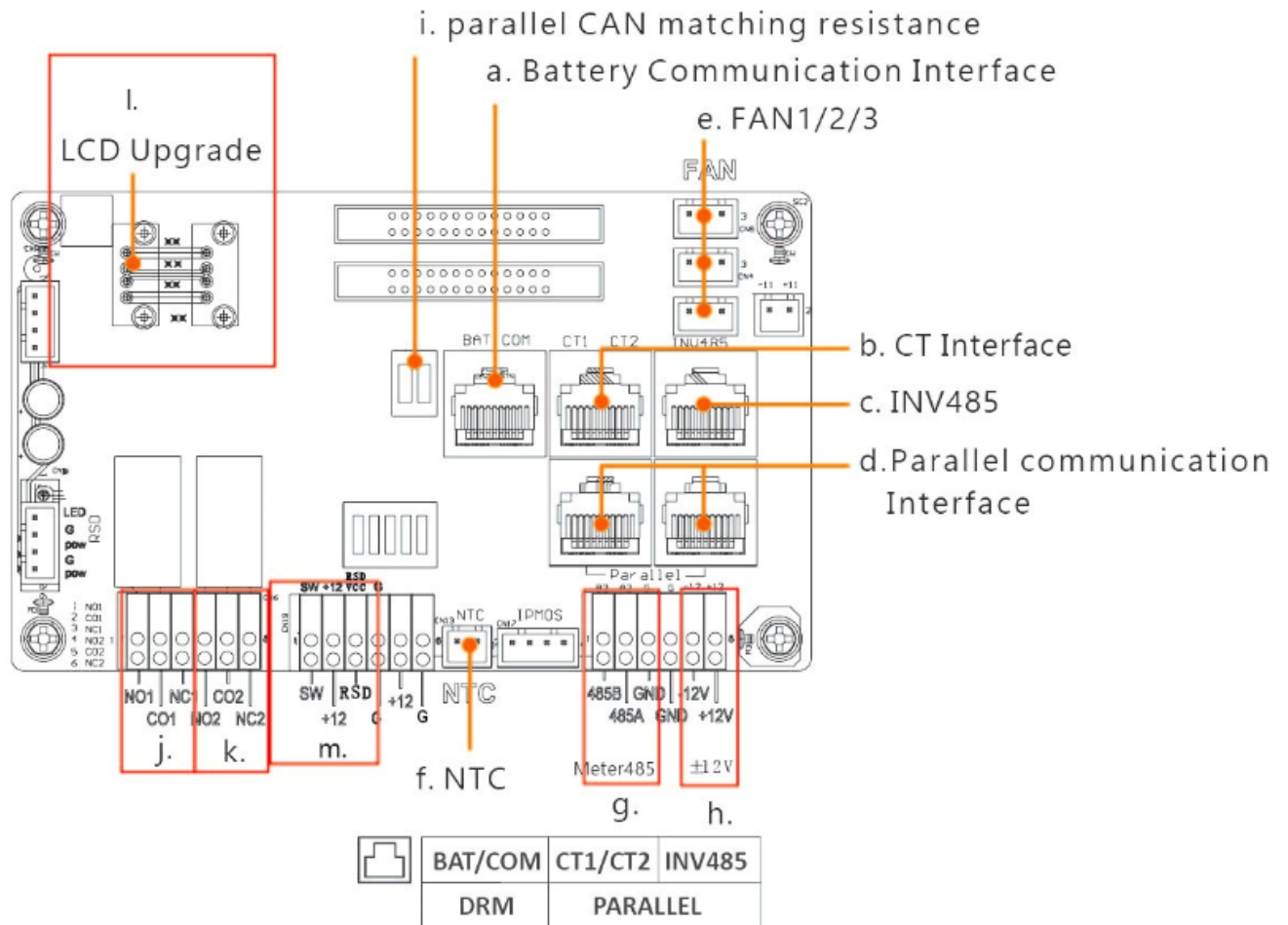

- a. Battery communication port (CAN & RS485)
- b. CT interface
- c. INV 485: debugging port
- d. Parallel communication port
- e. Fans 1/2/3
- f. Temp sensor connection for lead-acid battery
- g. Meter 485B & 485A: for meter communication

- h.  $\pm 12V$ : reserved for customer use, 500mA max
- i. CAN matching resistance: set DIP switch when using inverters in parallel
- j. Connection for generator auto-start function: GEN (NO, NC)
- k. Reserved: DRY (NO, NC)
- l. LCD UI upgrade port
- m. RSD Terminals

## Back View of the Cable Box Knockouts

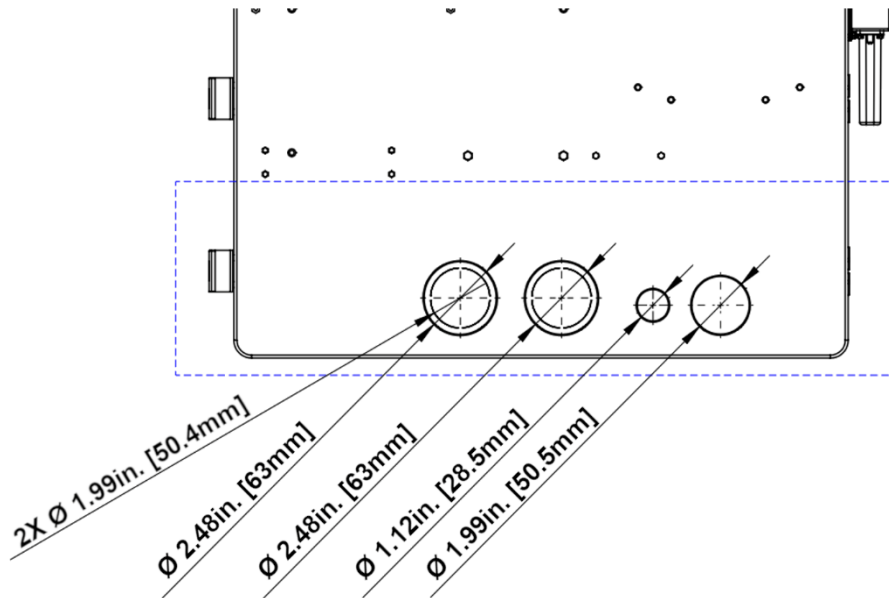

## Bottom View of Cable Box Knockouts

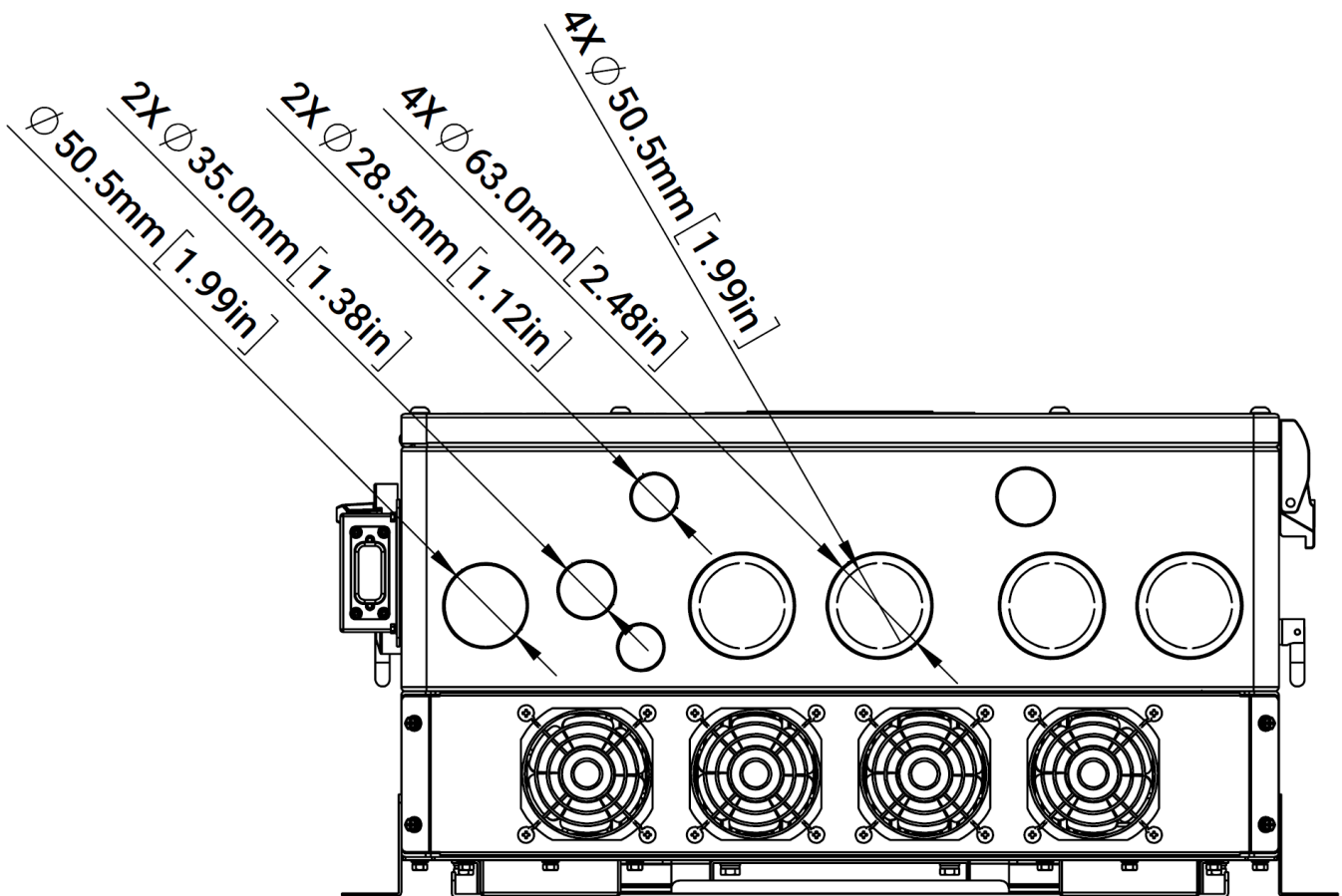

## 8.2 PACKING LIST

When the product is unpacked, the contents should match those listed below:  
 Pictures for reference only.

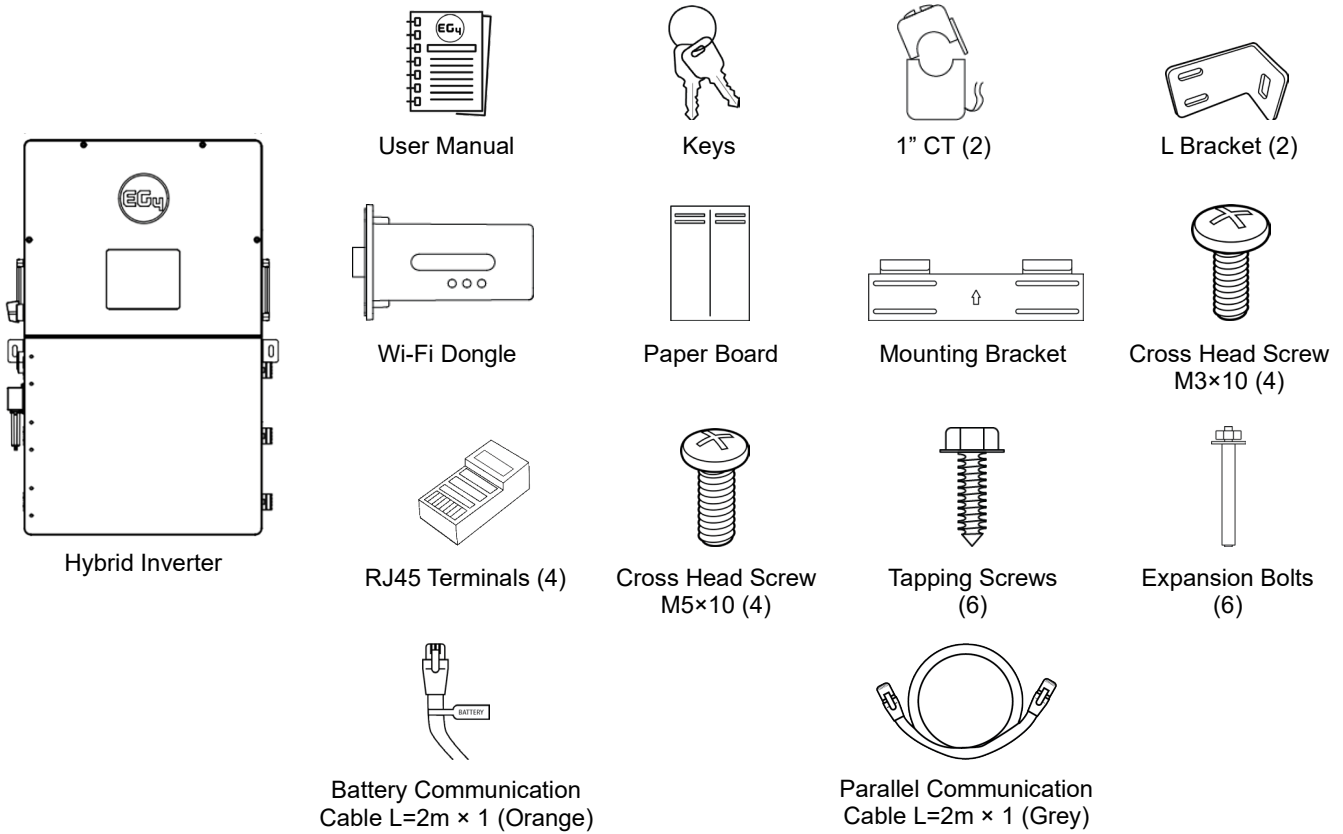

## **9. LOCATION SELECTION & INSTALLATION TOOLS**

### **9.1 RECOMMENDED TOOLS**

- Hand truck with all-terrain tires
- Tape measure
- Drill and drill bits (5/16)
- Wire strippers
- Small straight slot
- Lineman's Pliers, rabbit ears or side cutters
- M8 Hex
- M5 Hex
- Multimeter
- Tech screwdriver
- 14 mm or 9/16 socket for anchors
- Medium flat head screwdriver for PV connection
- 13 mm or 1/2 socket for lag screws
- Level
- Channel Locks
- Self-tapping screws (2)
- Torque wrench
- Heavy duty wood screws (4) – if anchoring in wood OR Hammer Drill or masonry bit (9/16)—if anchoring in concrete

## 9.2 INSTALLATION LOCATION INFORMATION

The battery and inverter are designed to be installed indoors or outdoors. Units used for indoor residential use are only intended to be installed in attached or detached garages, sheds, enclosed utility closets, basements, storage or utility spaces within dwelling units. **Units are not intended for installation in habitable spaces and living spaces in dwelling units.**

### CAUTION

Ensure a minimum installation space volume of 79.6 m<sup>3</sup> if not ventilated. This ensures flammable gas remains below 25% of the lower flammable limit (LFL) in case of thermal runaway. Room volume is based on released gases and the number of battery cells affected during testing. Adding more batteries does not require a larger installation location as tests showed no propagation between units. Required installation volume may be reduced with proper ventilation per local code and jurisdictional requirements.

- Verify proper spacing at least 5.9 in. (150 mm) of space on the left and right side of the inverter and at least 11.81 in. (300 mm) above the unit and spacing between WallMount All Weather 280Ah lithium batteries is at least 6 in. (152.4 mm) on each side of the units for adequate airflow and operations. Ensure equipment is mounted away from all combustible materials.

### NOTE

Six inches is the minimum allowable spacing between WallMount 280Ah All Weather batteries per UL 9540A testing. Consult the AHJ prior to installation to see if they allow reduced spacing between batteries. If not, follow the applicable state or local building and fire codes' spacing requirements.

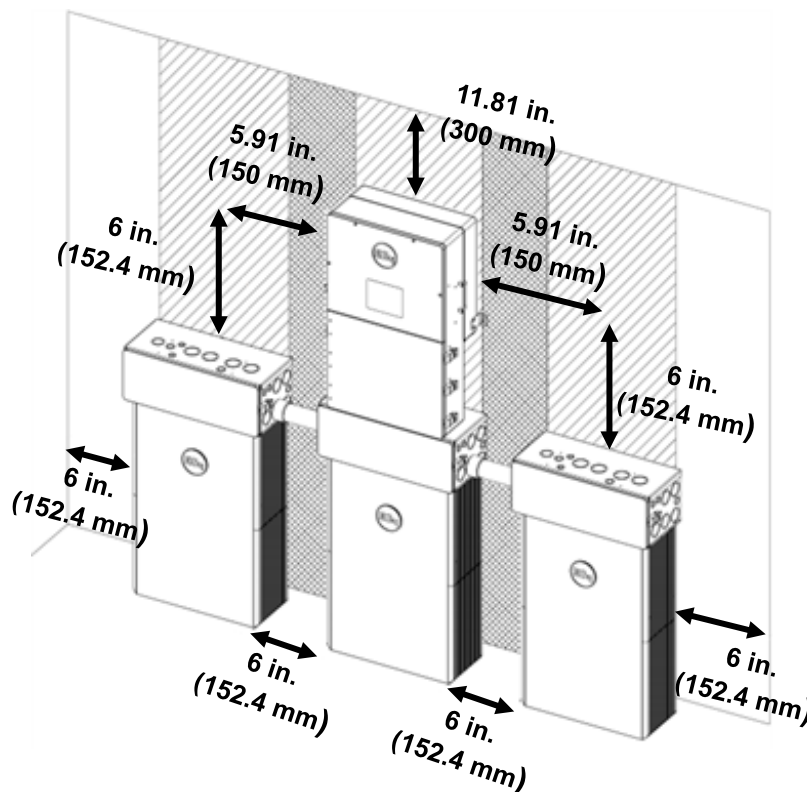



## NOTE

Prior to installation, confirm installation requirements with the AHJ where the install is taking place as they may have additional requirements IAW (In Accordance With) state or local building and fire codes.

- The mounting wall should be strong enough to bear the weight of the inverter.
- The battery is designed to be installed indoors or outdoors. Units used for indoor residential use are only intended to be installed in attached or detached garages, sheds, enclosed utility closets, basements, storage or utility spaces within dwelling units. Units are not intended for installation in habitable or living spaces within dwelling units and are not intended for installation near marine environments.
- The battery can be installed against a flat wall, but the weight of the battery should not be fully supported by the wall. To help with this requirement, the battery comes with pre-installed feet that should be used to carry the weight of the battery.
- Verify the mounting surfaces are made of non-combustible material. If this is not possible, then the units **MUST** have a minimum of 2 in. (50.8 mm) clearance from the wall. Also note that whatever mounting solution that is used to grant the 2 in. clearance from the wall **MUST** be made of a non-combustible material.
- If installing the battery on flat ground as a standalone unit, ensure there is proper drainage on the ground surrounding the battery to maintain integrity of the module over time and prevent damage from flooding.
- Verify each inverter and battery are mounted upright.
- Never position the inverter in direct sunlight, rain, or snow. Refer to the figure below and choose a well-shaded site or a shed to protect the inverter from the elements. The inverter should be installed upright on a vertical surface.
- The inverter and battery are heavy. Use team-lift technique and/or lift assist equipment to carry and lift the units.

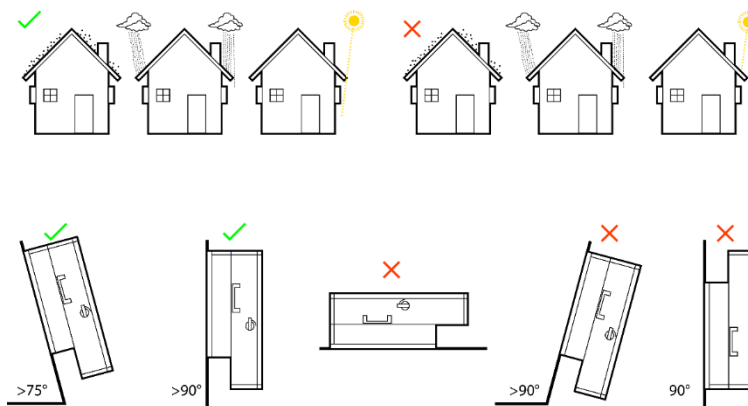

## TEAM LIFT

The battery will be shipped with temporary lifting handles for removing the battery from its packaging. The battery is very heavy. Use the team-lift technique during installation and remove the temporary handles before making any connections within the system.



## CAUTION

Do not make any electrical connections until the system is fully installed.

## 9.3 X-BRACKET OVERVIEW

There are two sets of mounting holes on the x-bracket. The outermost holes in the image below are used for the 18kPV. The innermost holes are for the 12kPV, FlexBOSS18, and FlexBOSS21.

### X-bracket (v1)

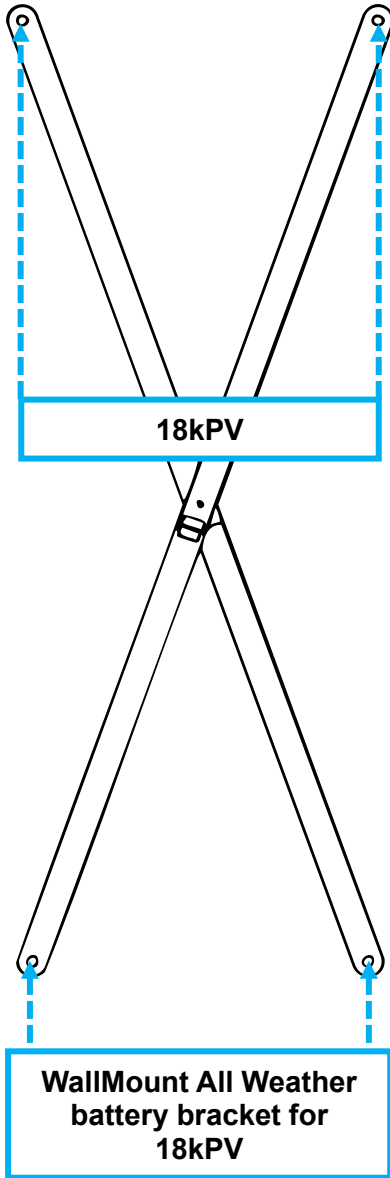

### X-bracket (v2)

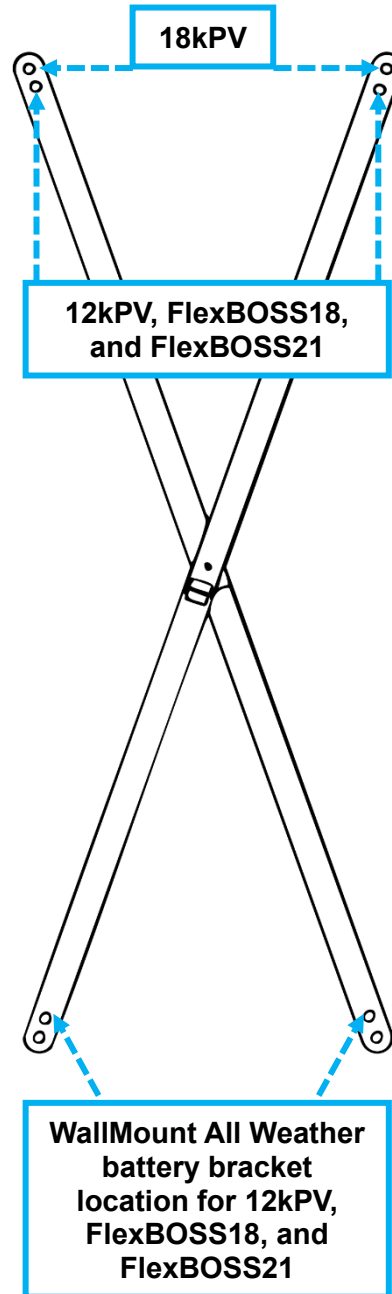

## 9.4 INSTALLING THE BATTERY

### NOTE

EG4 recommends installing the battery with at least 6-inch clearance on each side of the battery, back and front sides excluded, to easily access the side panel.

1. Remove the 4 set screws holding the mounting bracket to the back of the battery pack and set them to the side.
2. Remove the mounting bracket from the battery.
3. Position the top of the mounting bracket on the wall at the desired mounting height, with a minimum clearance from the ground of 28.065 in. (712.85mm).
4. Using a level, ensure the bracket is level and drill (using a 3/8" bit) 6 holes to accommodate the mounting hardware used.
5. Secure the mounting bracket to the wall using the included expansion bolts or appropriate hardware required for the mounting surface.
6. Attach the battery pack to the mounting bracket. Using the team-lift technique, lift the battery and hook the back flange onto the front flange of the mounting bracket.
7. Secure the battery to the mounting bracket using the 4 included side screws.
8. Finally, properly ground the battery, attaching a grounding conductor to the M6 grounding screw on top of the battery to the Equipment Grounding System. **DO NOT GROUND THE NEGATIVE BATTERY CABLE!**

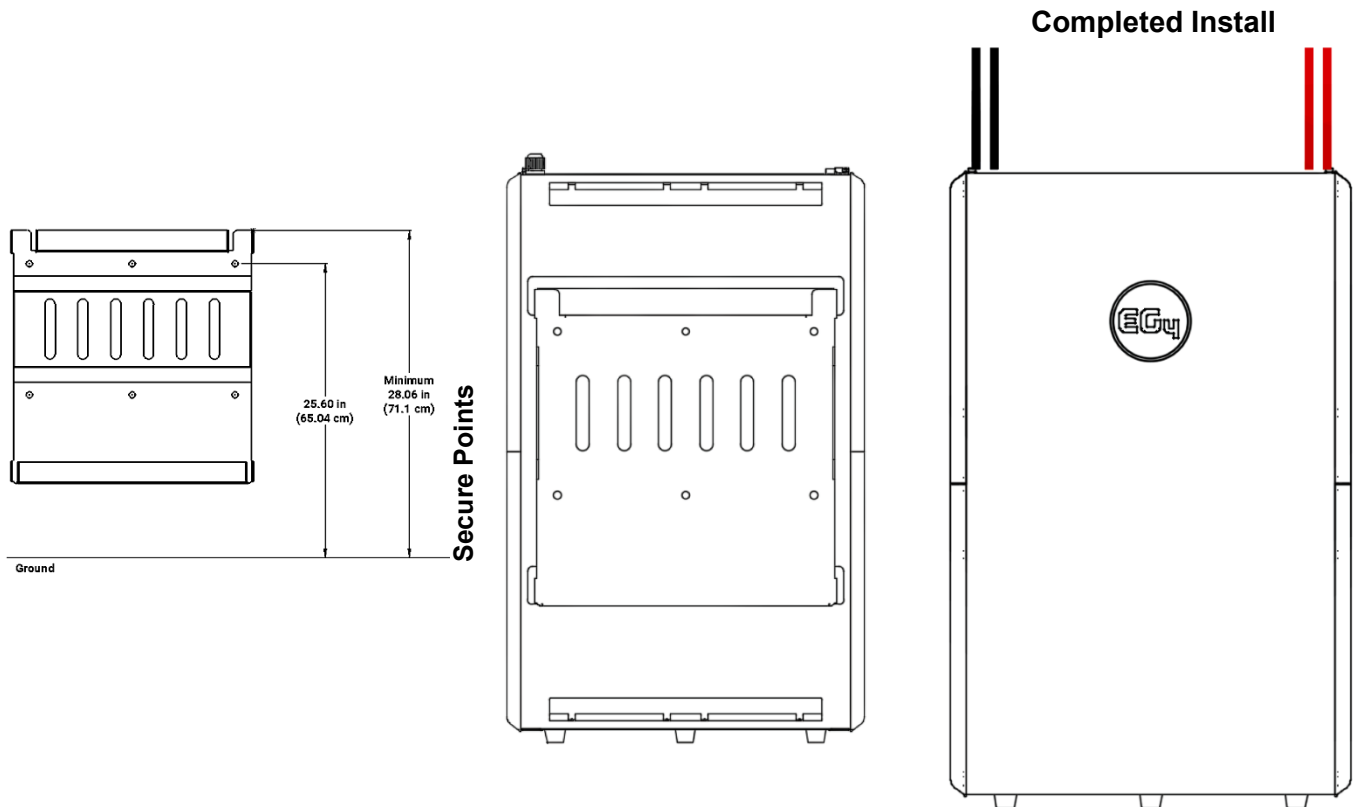

## 9.5 INSTALLING THE CONDUIT BOX (OPTIONAL)

When the WallMount battery is mounted, attach the conduit box (sold separately) to the top of the WallMount battery using the included hardware. The conduit box is an optional accessory. It is not an included component of the UL9540 ESS listing. See specifications on conduit box for certification and/or weather rating information.

1. Remove the four screws on the top of the battery and retain them for use in Step 2.
2. Identify the four screws that line up with the thumb screws located in Step 1. Place the conduit box on top of the battery and use the thumb screws to attach the box to the top of the battery.
3. Finally, properly ground the battery, attaching a grounding conductor to the M6 grounding screw on top of the battery to the equipment grounding system. **DO NOT GROUND THE NEGATIVE BATTERY CABLE!**

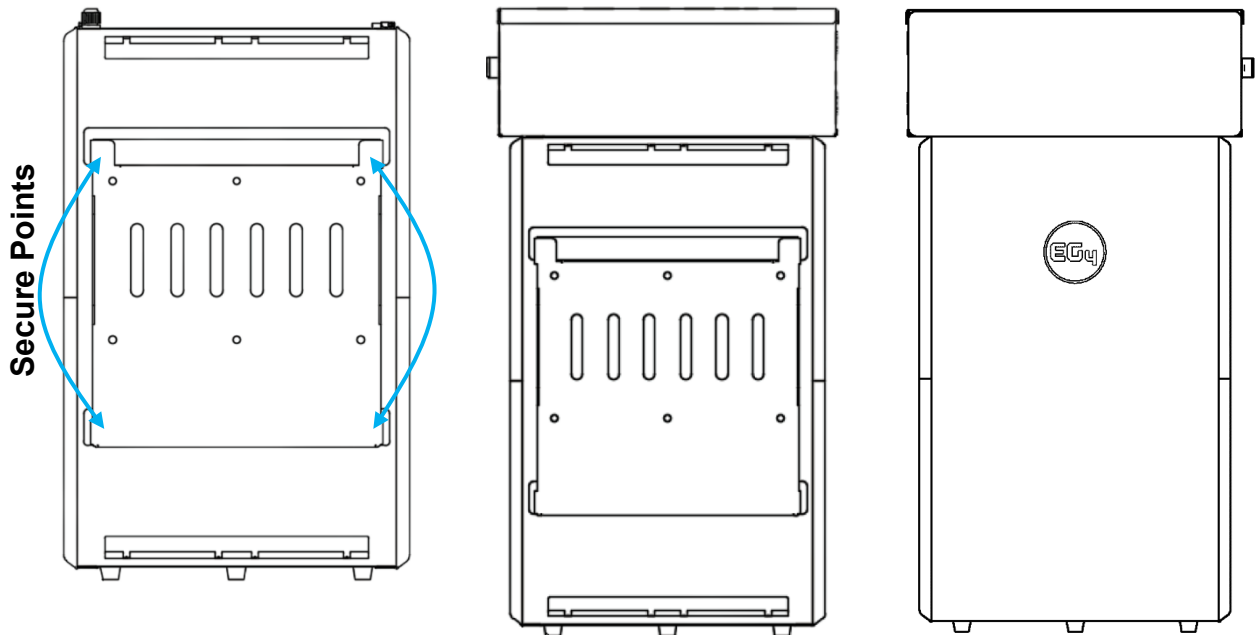
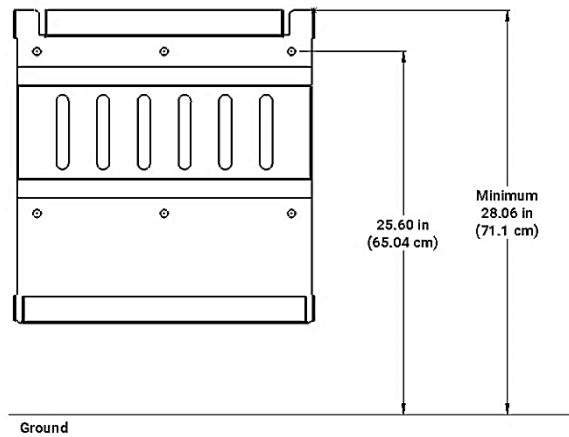

## 9.6 WITH EG4<sup>®</sup> 18KPV INVERTER

### NOTE

If not mounting into concrete or brick using the included expansion bolts, ensure bolts are mounted into both studs or supportive material. The battery is 300 lbs. Ensure full mounting support.

1. Place mounting bracket on wall at proper mounting height (Min. 28.0625 in.) from the ground; use a level to make sure the bracket is straight, and mark mounting hole locations. Drill holes to accommodate mounting hardware being used.

### NOTE

The mounting bracket set at 28.1 in. from the ground allows the battery to sit on the ground.

2. Align the provided X-bracket with the holes on the mounting bracket and secure both to the wall, using the included expansion bolts (concrete/brick walls) or appropriate hardware required for the mounting surface. The X-bracket will be behind the mounting plate, against the wall.
3. Using the X-bracket as a guide, attach the 18kPV mounting bracket using the appropriate hardware required for the mounting surface.
4. Attach the WallMount battery pack to the mounting bracket. To accomplish this, lift the battery up and hook the flange on the back of the battery into the flange on the front of the mounting bracket. Secure the battery to the mounting bracket with the 4 included side screws.

Note: The battery is very heavy. Please use the team lift technique to prevent damage to personnel and/or equipment

5. Attach the conduit box (sold separately) to the top of the WallMount battery using the included hardware.
6. Attach the 18kPV to the inverter mounting bracket making sure that the holes of the inverter align with the conduit box and secure to each other with the included hardware.
7. Finally, properly ground the battery, attaching a grounding conductor to the M6 grounding screw on top of the battery to the Equipment Grounding System.

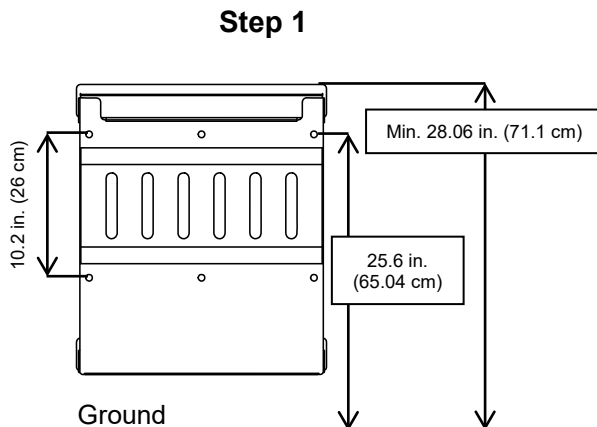

**Step 2 (back view)**

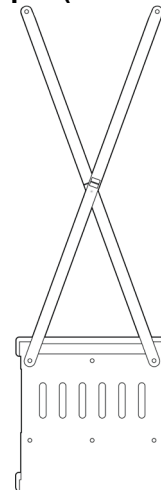

Step 3 (back view)

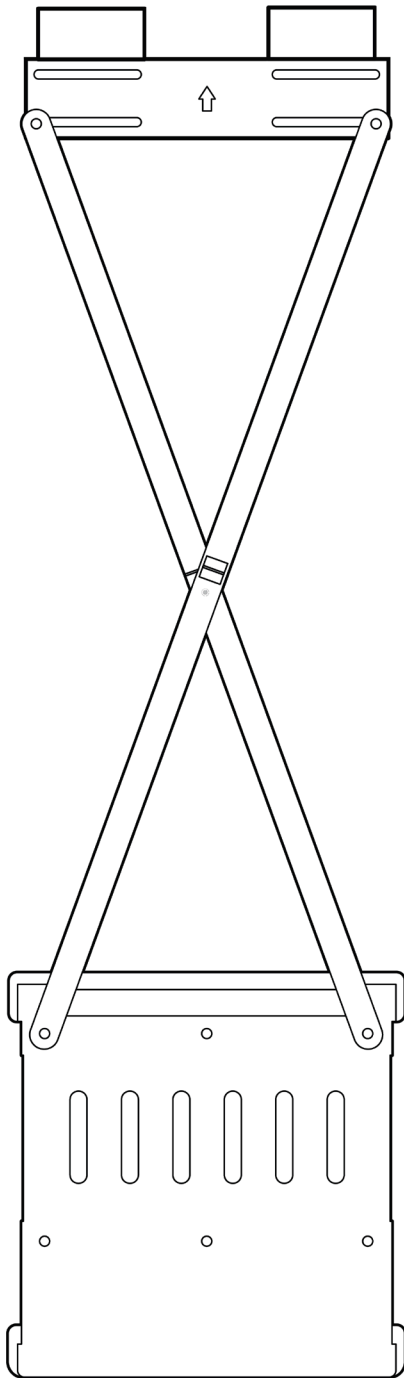

Step 4 (back view)

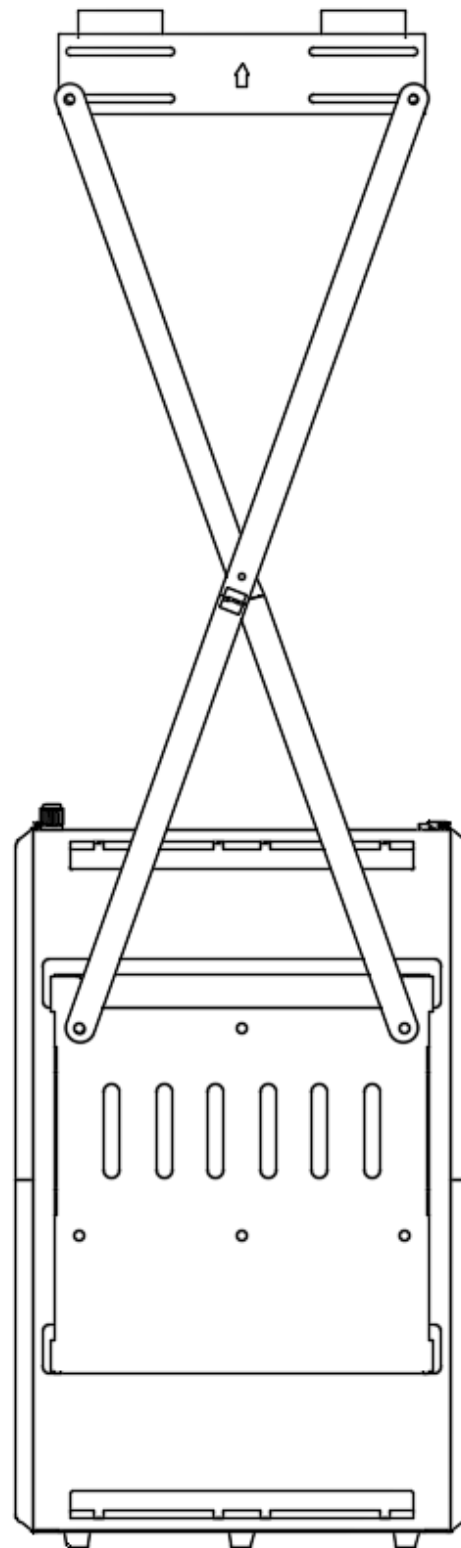

Step 5 (back view)

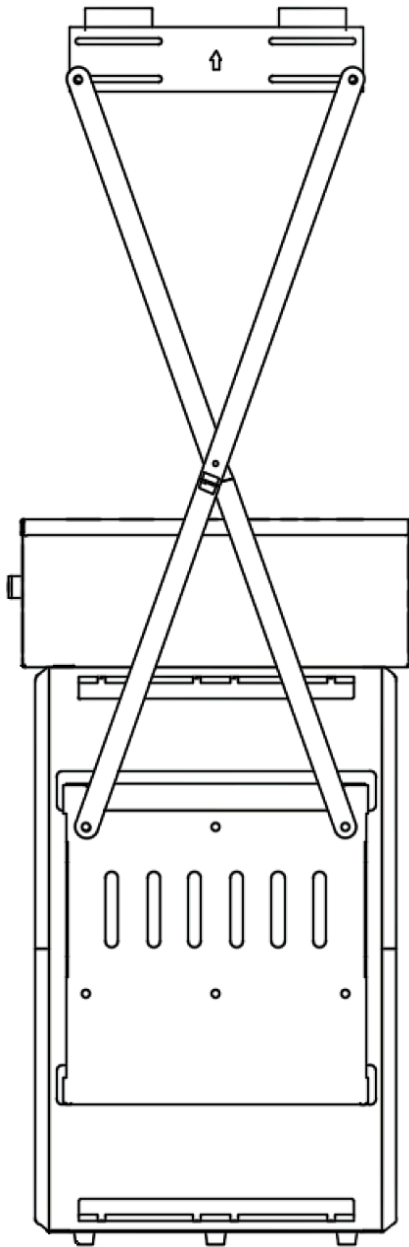

Step 6 (back view)

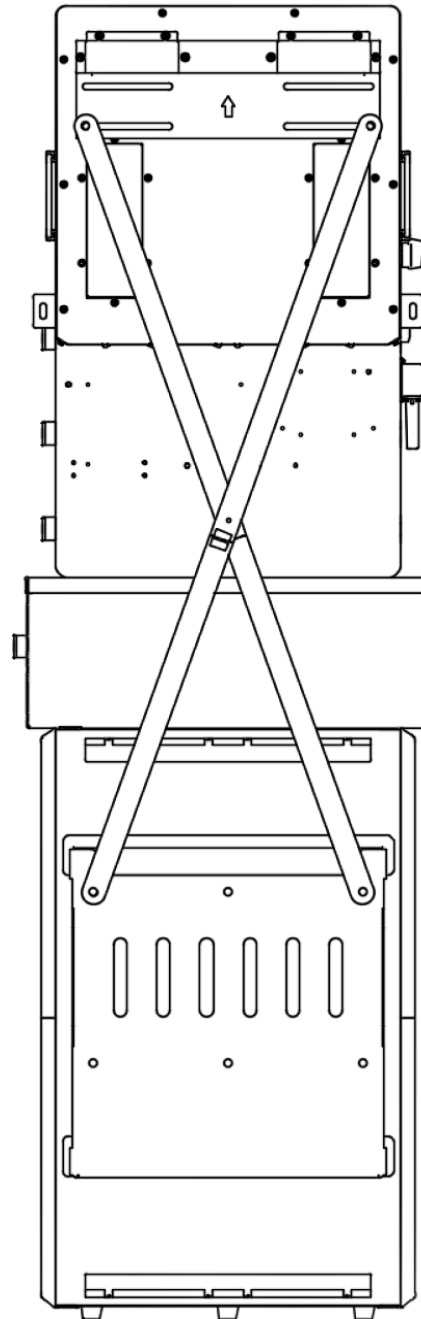

## Final - Front View w/ Dimensions

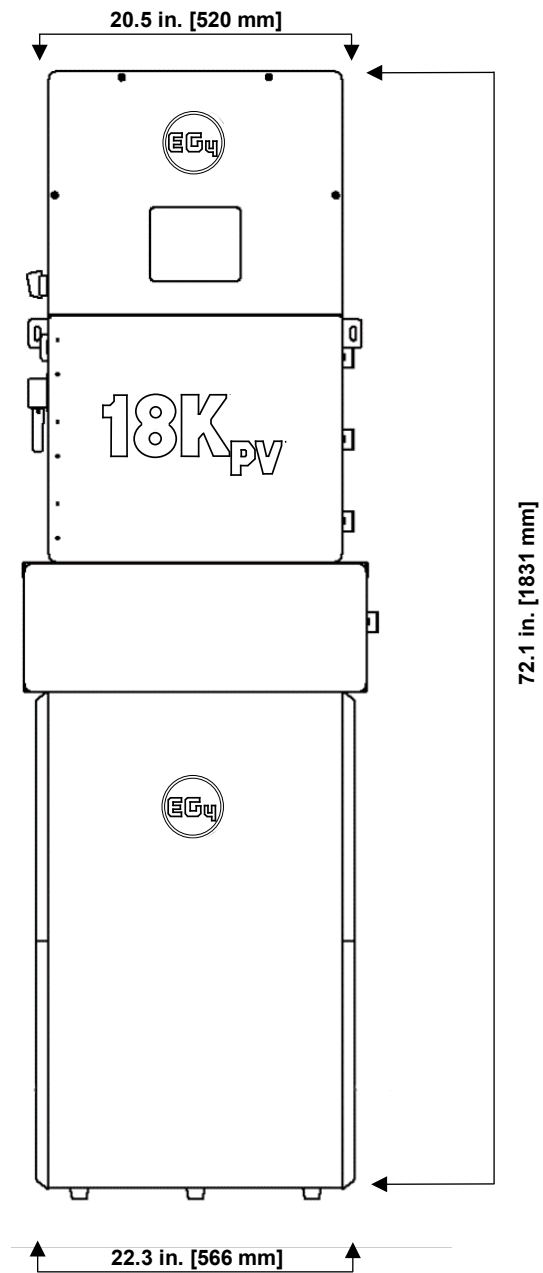

## 9.7 WITH EG4® 12KPV INVERTER

### NOTE

If not mounting into concrete or brick using the included expansion bolts, ensure bolts are mounted into both studs or supportive material. The battery is 300 lbs. Ensure full mounting support.

- Place mounting bracket on wall at proper mounting height (Min. 28.0625 in.) from the ground; use a level to make sure the bracket is straight, and mark mounting hole locations. Drill holes to accommodate mounting hardware being used.  
The images below correlate to the steps taken in this list.

### NOTE

The mounting bracket set at 28.1 in. from the ground allows the battery to sit on the ground.

- Align the innermost holes on the X-bracket with the holes on the mounting bracket and secure both to the wall, using the included expansion bolts (concrete/brick walls) or appropriate hardware required for the mounting surface. The X-bracket will be behind the mounting plate, against the wall.
- Using the innermost holes on the X-bracket as a guide, attach the inverter mounting bracket using the appropriate hardware required for the mounting surface.
- Attach the WallMount battery pack to the mounting bracket. To accomplish this, lift the battery up and hook the flange on the back of the battery into the flange on the front of the mounting bracket. Secure the battery to the mounting bracket with the 4 included side screws.

### TEAM LIFT

The battery is very heavy. Use the team-lift technique during installation.

- Attach the conduit box (sold separately) to the top of the WallMount battery using the included hardware.
- Attach the 12kPV to the inverter mounting bracket making sure that the holes of the inverter align with the conduit box. Secure the conduit box to the inverter with the included hardware (if applicable).

**Step 1 (front view)**

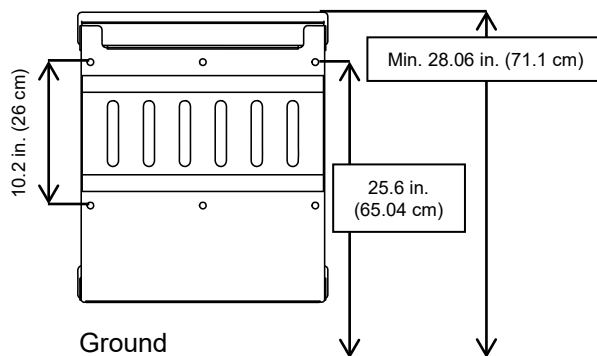

**Step 2 (back view)**

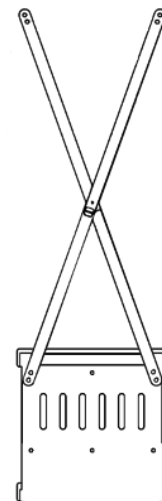

Step 3 (back view)

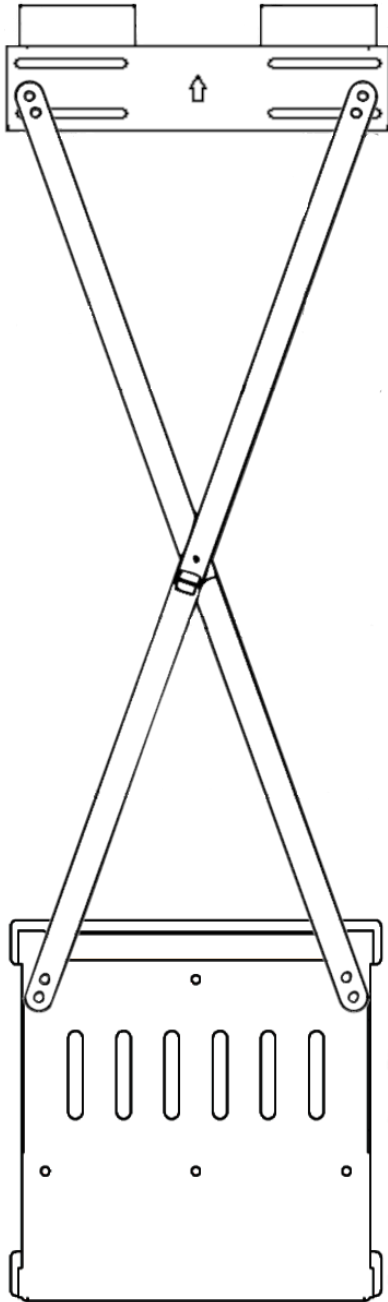

Step 4 (back view)

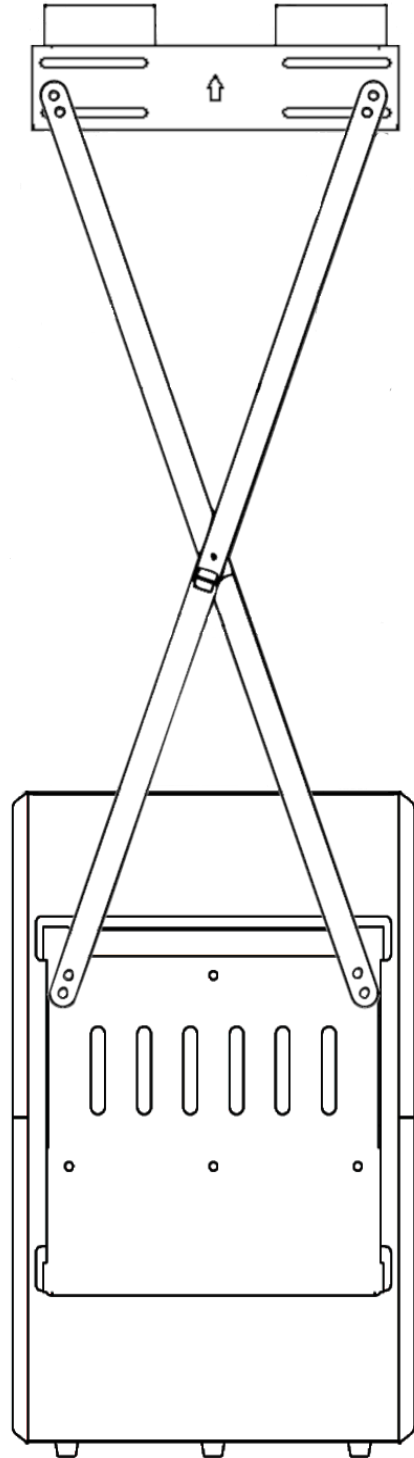

Step 5 (back view)

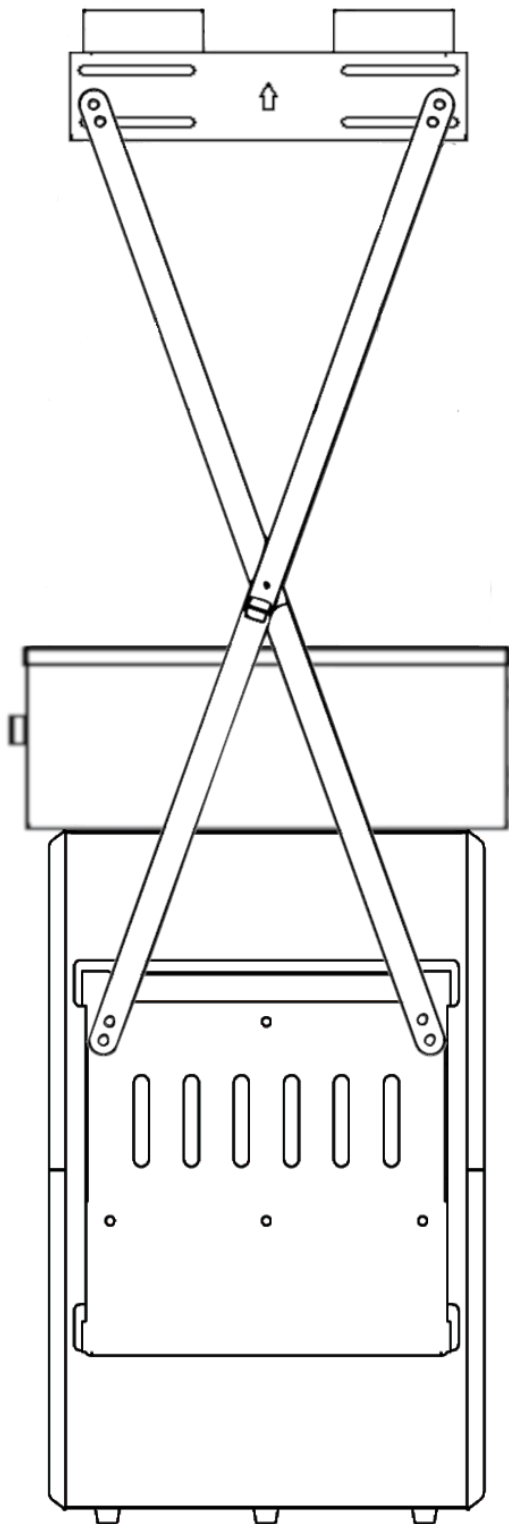

Step 6 (back view)

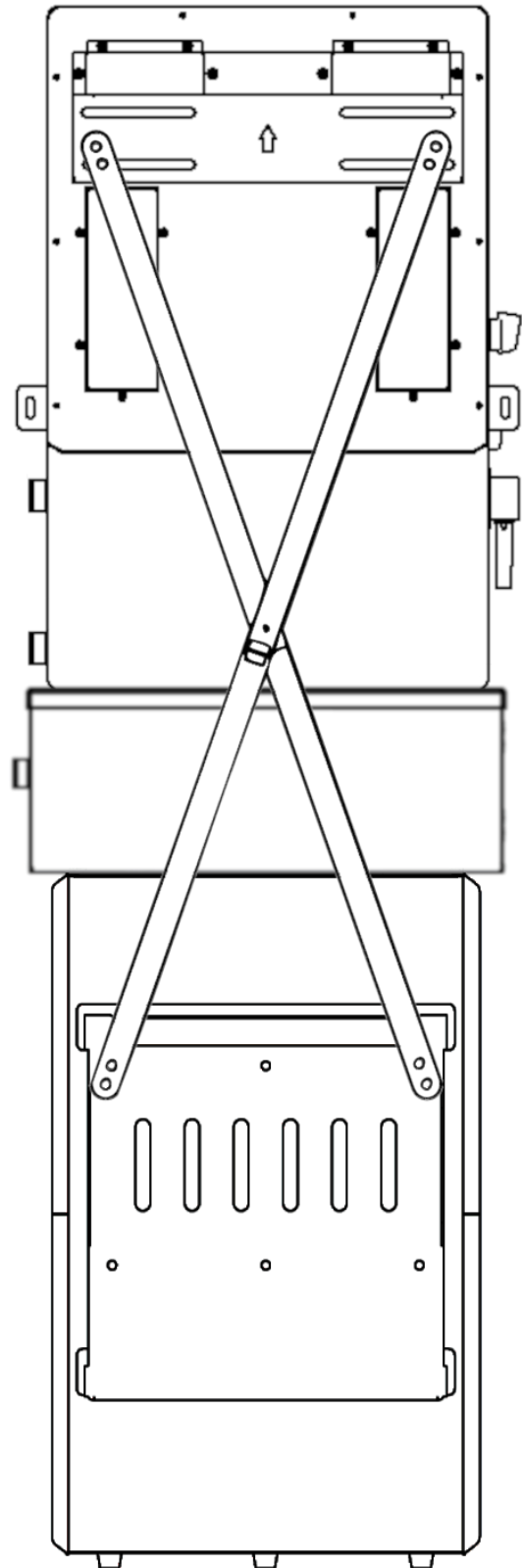

## Final - Front View w/ Dimensions

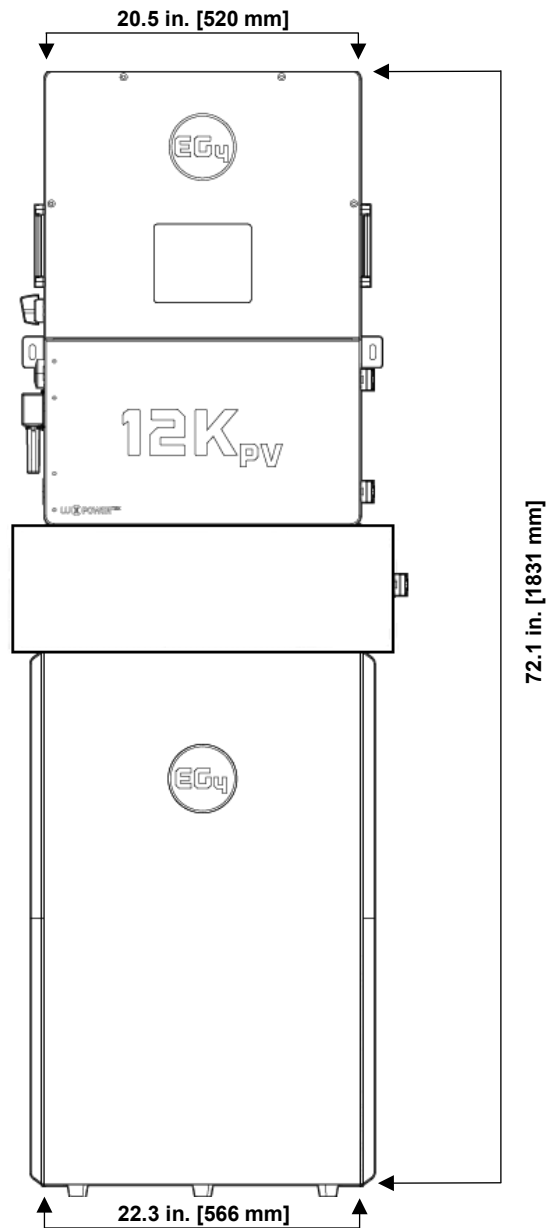

## 9.8 INSTALLING THE 18KPV INVERTER

The inverter is designed to be wall-mounted on a vertical, solid **non-combustible** surface such as brick or concrete. Two or more people may be needed to install the inverter due to its weight. The slots on the mounting bracket can accommodate various stud spacings from 12 in. (305 mm) to 16 in. (406 mm).

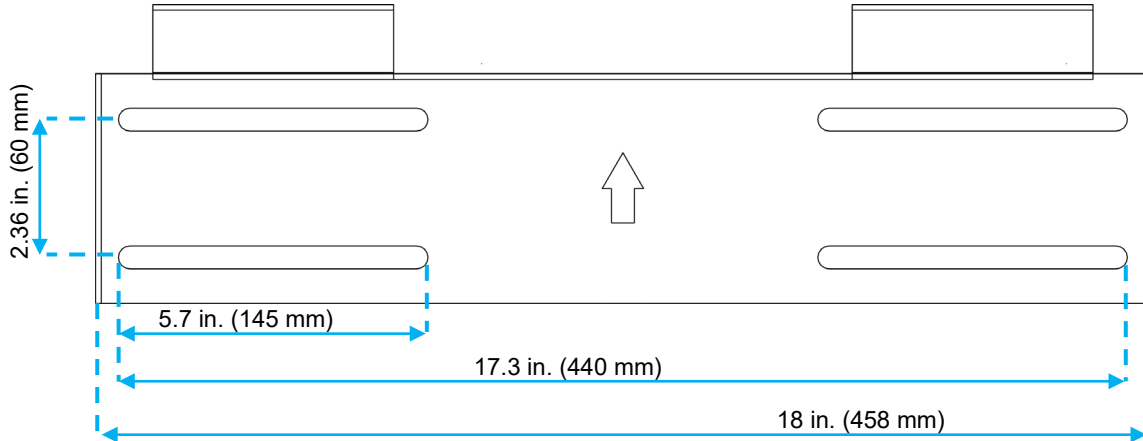

### Mounting Steps:

1. Select a location for the inverter's final placement.
2. Use the cardboard template to mark where the mounting bracket screws will be installed.

When installing the bracket to studs, verify the marks for the screws are centered over a stud.

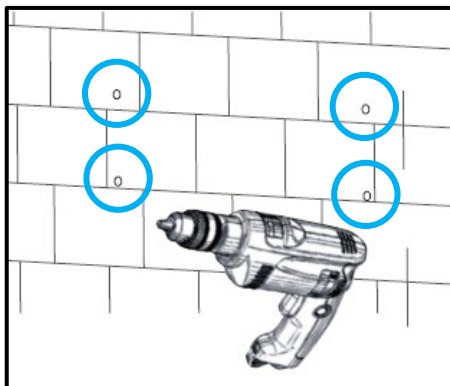
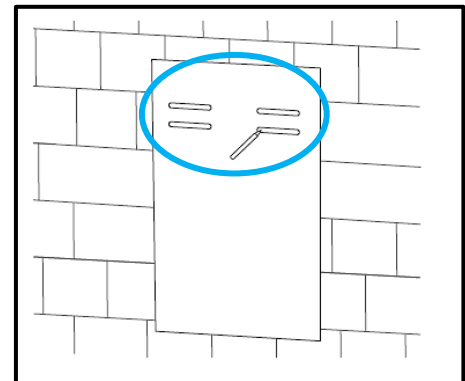

3. When installing the bracket to concrete or brick, drill 5/16 in. (8 mm) diameter holes on the marks, making sure the holes are deeper than 2 in. (50 mm) when using the included expansion bolts. When installing the bracket to studs, drill a pilot hole recommended for the screw diameter used. Ensure the studs are spaced 12 to 16 in. apart.

4. For concrete or brick wall installation, insert the expansion bolts into the drilled holes. Install the bracket to the wall, ensuring the arrow is pointing up. Use the corresponding nuts and washers (packaged together with the expansion bolts) to affix the bracket to the wall. For stud wall installation, use the proper screws and affix the bracket to the wall.

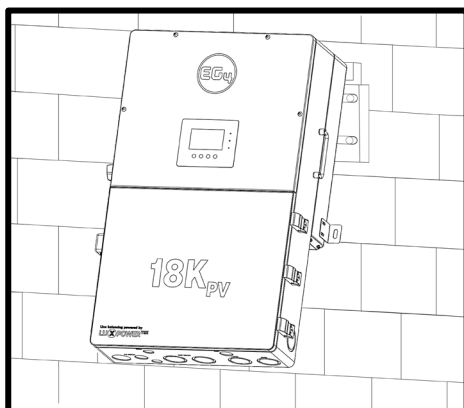
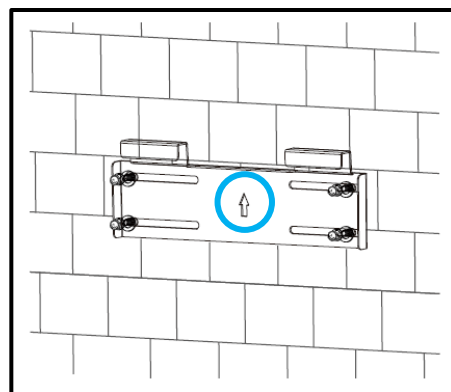

5. Use the team lift technique, place the inverter on to the wall bracket, securing it to the wall.

6. Temporarily mount the L bracket to the side of the inverter (located at the bottom, one on each side). Mark holes on the wall based on the hole location on the right-angled bracket (repeat this step for both sides).

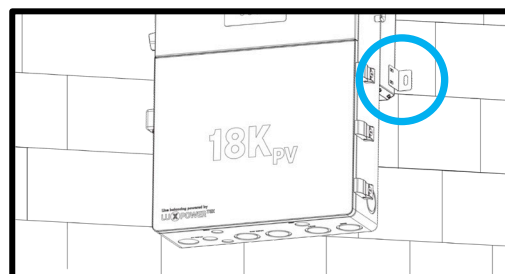

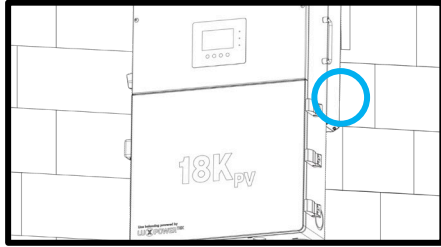

7. Remove the angle bracket and drill a hole at the marking. Use the drill bit size based on the anchor type or screw size as directed in step 3 (repeat this step for both sides).

8. Attach the angle brackets (one on each side) to the inverter and to the wall using the correct hardware. Once the bracket is secure, the wall installation is complete.

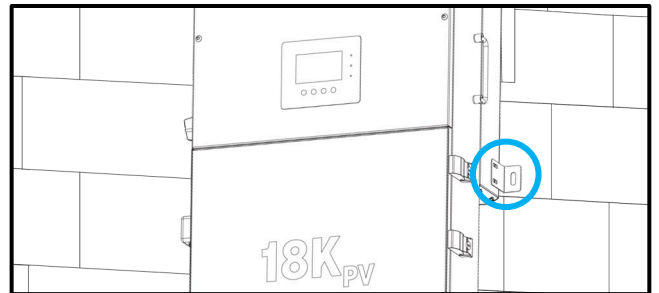

## 9.9 INSTALLING THE 12KPV INVERTER

The 12kPV is designed to be wall mounted using a wall mounting bracket. The mounting location must be a vertical, solid mounting surface, such as concrete or brick, and be able to withstand the weight of the unit. The surface must be made of non-combustible material. The slots on the mounting bracket can accommodate various stud spacings from 12 in. (305 mm) to 16 in. (406 mm). See image below.

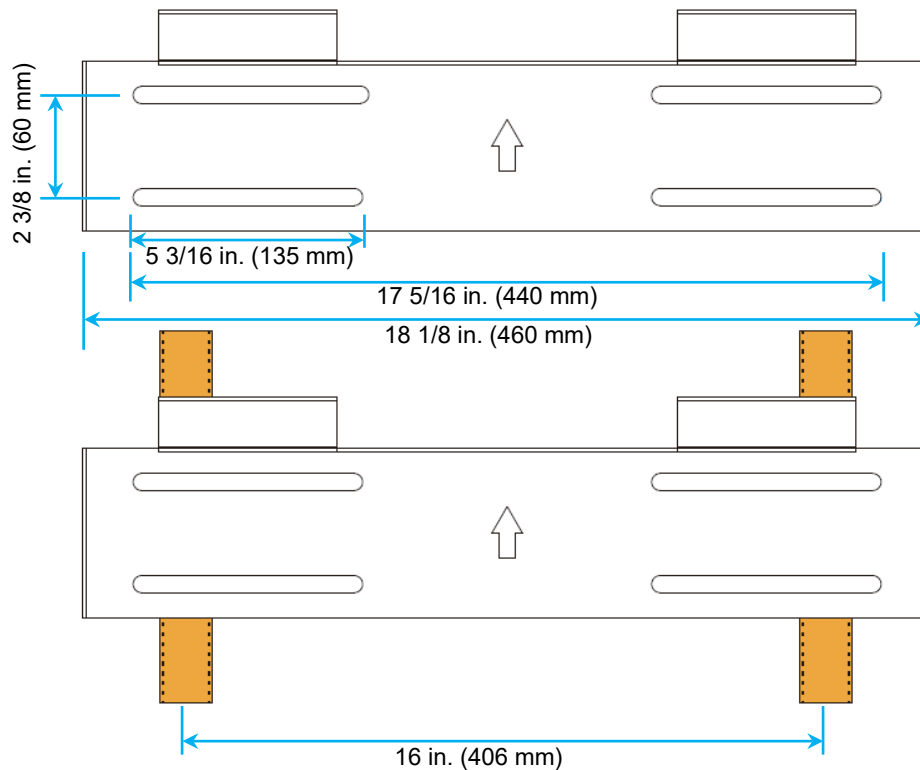

### MOUNTING STEPS

Follow the steps below if mounting on brick or concrete:

1. Using the included template, mark the hole positions for the mounting bracket.
2. Drill four 5/16 in. diameter holes, ensuring the holes are deeper than 2 in.
3. Insert the expansion bolts into the drilled holes and tighten.
4. Use the included nuts and washers, packaged together with the expansion bolts, to secure the wall-mount bracket to the wall.
5. Using the team-lift technique, hang the inverter on the wall-mount bracket and lock it to the wall with two self-tapping screws (not included) and the included L-brackets.

For mounting on concrete board with wooden studs:

1. To ensure correct mounting, follow steps 1 and 2 above before proceeding.
2. Fasten the mounting bracket to the studs with four heavy duty wood screws.
3. Using the team-lift technique, hang the inverter on the wall-mount bracket and lock it to the wall with two self-tapping screws (not included) and the included L-brackets.



### NOTE

Wood screws and self-tapping screws are not included with the purchase. Installers will need to source all necessary screws before installation.

## 9.10 ORIENTATION EXAMPLE

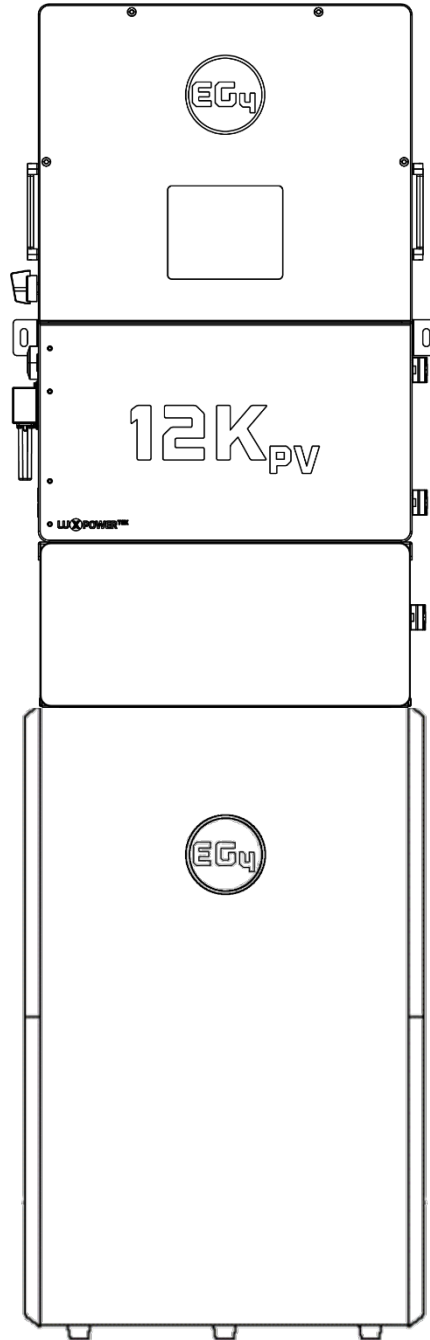

## 10. PRE-WIRE STEPS & WIRING (BATT, PV, AC)

### 10.1 18kPV WIRE SIZING

Reference the tables below for wire size and torque recommendations depending on the type of wire and connection.

#### Battery Wire Sizing

# of cables	Cable Size (90°C)	Max. Distance	Torque for cable connection
2 sets	1/0AWG (53.5 mm <sup>2</sup> )	10 ft.	165 in-lbs. (18.6Nm)
2 sets	2/0AWG (67.4 mm <sup>2</sup> )	20 ft.	165 in-lbs. (18.6Nm)
1 set	4/0AWG (107 mm <sup>2</sup> )	10 ft.	Max. 275 in-lbs. (31.1Nm)
1 set	250kcmil (127 mm <sup>2</sup> )	20 ft.	Max. 275 in-lbs. (31.1Nm)

#### PV Wire Sizing

Cable Size	Minimum Insulator Voltage
10 AWG – 6 AWG (Max.) (6 mm <sup>2</sup> – 16 mm <sup>2</sup> )	600V

#### AC Wire Sizing

Terminal Connection	Wire Size	Torque Values
GRID	6 – 4/0AWG (26.7 mm <sup>2</sup> – 107 mm <sup>2</sup> )	95 – 165 in-lbs. (10.7Nm – 18.6Nm) depending on wire
GEN	Size according to generator output	95 – 165 in-lbs. (10.7Nm – 18.6Nm) depending on wire
LOAD	6 – 4/0AWG (26.7 mm <sup>2</sup> – 107 mm <sup>2</sup> )	95 – 165 in-lbs. (10.7Nm – 18.6Nm) depending on wire

*\*Consult installer to ensure that appropriate cable size is used due to various factors such as distance, operating voltage, and amperage.*

## 10.2 12kPV WIRE SIZING

Reference the tables below for wire size and torque recommendations depending on the type of wire and connection.

### Battery Wire Sizing

CABLE SIZE	MAX. DISTANCE	TORQUE VALUES
4/0 AWG (107 mm <sup>2</sup> )	10 ft.	Max. 22.9 ft-lbs. (31.1Nm)
250 Kcmil (127 mm <sup>2</sup> )	20 ft.	Max. 22.9 ft-lbs. (31.1Nm)

### PV Wire Sizing

Cable Size	Minimum Insulator Voltage
10 AWG – 6 AWG (Max.) (6 mm <sup>2</sup> – 16 mm <sup>2</sup> )	600V

### AC Wire Sizing

TERMINAL CONNECTION	CABLE SIZE	TORQUE VALUES
GRID	Max. 4 AWG (21.2 mm <sup>2</sup> )	17.7 in-lbs. (2Nm)
GEN	Max. 4 AWG (21.2 mm <sup>2</sup> )	17.7 in-lbs. (2Nm)
LOAD	Max. 4 AWG (21.2 mm <sup>2</sup> )	17.7 in-lbs. (2Nm)

*\*Consult installer to ensure that appropriate cable size is used due to various factors such as distance, operating voltage, and amperage.*

## 10.3 18kPV AND 12kPV RSD/ESS DISCONNECT

The inverter includes a rapid shutdown system that complies with 2017 and 2020 NEC 690.12 requirements. A rapid shutdown switch should be connected to the RSD terminals on the master inverter and mounted in a readily accessible location outdoors (*check with the AHJ for specific requirements*). For paralleled systems, the RSD needs only to connect to the master inverter. When the switch is engaged, it will shut down all inverters in parallel.

### NOTE

When using supported EG4 batteries in closed-loop communications with the inverter, the RSD also initiates ESS disconnect.

### External RSD

The system can also utilize an External E-Stop Switch if the local AHJ deems it necessary.

The external switch must be “Normally Open” by default, and “Closed” when the button is pressed for emergency shutdown.

If utilizing an external E-Stop switch, see the following subsection for instructions.

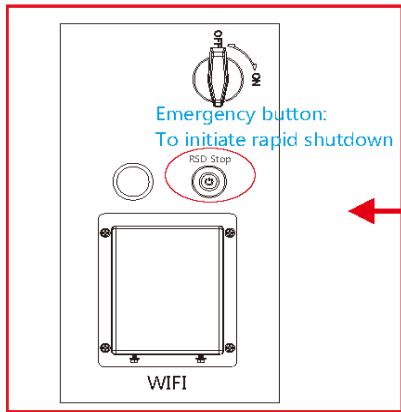
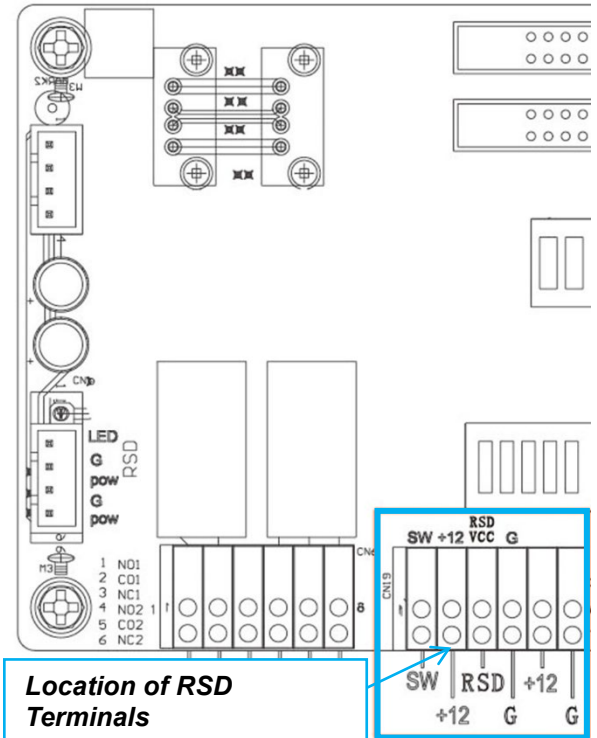

### RSD Transmitter

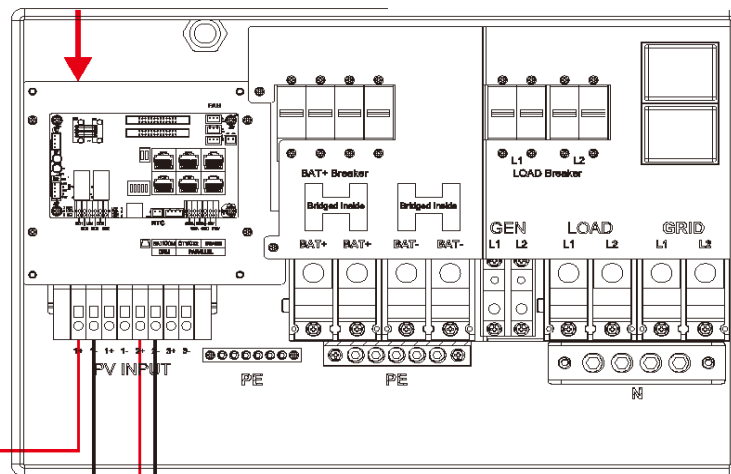

In case of emergency, press the rapid shutdown button to cut off the RSD power supply, in turn cutting the inverter's AC Output along with dropping the PV Conductors voltage to <30V in 30 seconds.

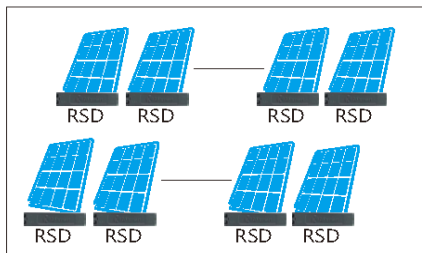

## External RSD Wiring Instructions



### NOTE

If the inverter does not have the RSD terminals shown in the image, contact the distributor for information regarding RSD installation.

For more information on Rapid Shut Down and installing a different RSD transmitter or for additional information on the APsmart RSD transmitter, scan the QR codes below.

Wire the E-Stop Switch into the RSD terminals according to the switch's specifications.

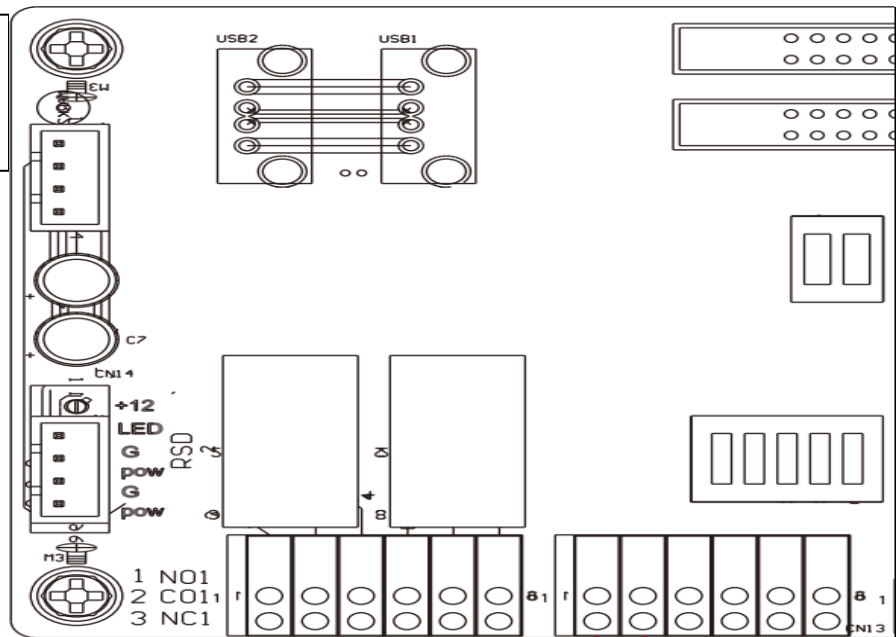

**E-Stop Switch**



Rapid Shut Down  
Wiring Guide



APsmart RSD Transmitter  
Module Removal

## 10.4 WALLMOUNT AW 280AH EMERGENCY STOP [RSD, ESS DISCONNECT]

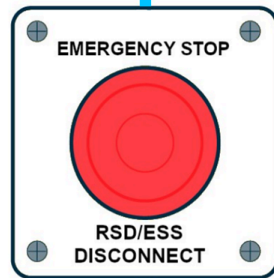
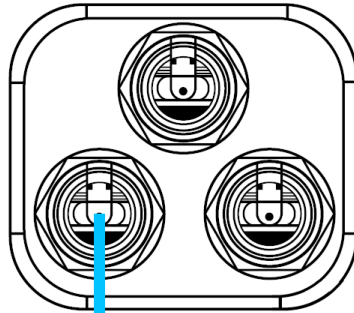

To inverter, RSD Initiator, or ESS Disconnect  
(Inverter recommended if compatible with inverter's RSD system)  
Normally Open (NO) or Normally Closed (NC) contacts depending on inverter

### Emergency Stop

The optional ESS disconnect can be used to shut down all batteries and inverters (if equipped) with the push of a button.

When paralleling multiple batteries, the ESS disconnect only needs to have connections made with the master battery.

This integrated safety feature ties directly into the battery communication system via an open Battery-Com port using a standard Cat-5/6 ethernet cable.

Pins 3 & 6 are used to communicate the emergency stop information to the batteries once the stop button is pressed.

If the inverter is equipped with rapid shut down (RSD) capabilities, the emergency stop feature can be used to initiate this function. Check with the local AHJ and NEC code for compliance.

## 10.5 BATTERY/INVERTER CONNECTION

### 18kPV CONNECTION

1. Place all breakers in the OFF position before connecting or disconnecting wires. Ensure that there is no voltage present with a voltmeter.
2. Strip 3/5 in. – 4/5 in. (15 mm – 20 mm) insulation from the cable end.
3. Route the battery power cable, connecting positive to BAT +, and negative to BAT -.
4. Secure the conduit fitting to the enclosure using the counter nut.
5. Fasten battery positive and negative cables to the mechanical terminals according to the markings with an M8 hex wrench, torquing to a maximum value of 22.9 ft-lbs. (31.1 Nm).

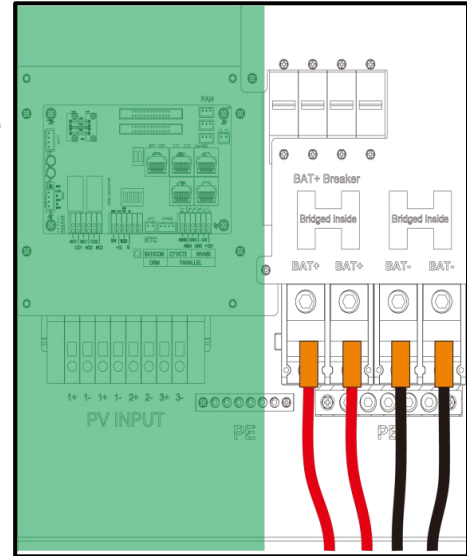

### 12kPV CONNECTION

1. Ensure all circuit breakers are open (off). Use a multimeter to test the wires and terminals for voltage. If no voltage is present, proceed to the next step.
2. Route the battery power cables, ensuring cables are long enough to span the distance between battery and inverter terminals, without making any connections.
3. Secure a conduit fitting to the enclosure using a counter nut.
4. Connect the battery positive and negative cables to the inverter's mechanical lugs using an M8 hex wrench, torquing to a maximum value of 22.9 ft-lbs. (31.1 Nm).



#### NOTE

Conduit fittings and counter nuts are not included with purchase. Installers will need to acquire all necessary conduit accessories before installation.

**Multiple Inverters:** If more than one inverter is installed, connect the battery communication cable to the inverter that will be used as the master inverter. All additional inverters will communicate with the master inverter through the parallel communication cable for all needed battery information.

**Multiple Batteries:** When using more than one battery, use the communication cable supplied with each battery to interconnect each battery, including the master battery. This allows the master battery to gather all battery data and provide it to the master inverter.

## 10.6 BATTERY CONNECTION

---



### DANGER

No connections should be made until proper polarity of cables has been confirmed.



### CAUTION

Make sure to install the communication cables into their respective ports. Improper installation may lead to component damage.

EG4 recommends double checking all points of connection before introducing power to the system to mitigate any potential issues.

---

Follow the steps outlined below to both test the inputs and wire the battery pack to the inverter.

1. Ensure all circuit breakers are open (off). Using a multimeter, check for voltage at all available disconnects and lines. Once no voltage is confirmed, proceed to the next step.
  2. Connect the included sets of 2/0 AWG (70mm<sup>2</sup>) with outdoor rated connectors to the battery's positive and negative terminals. The connectors will "click" when seated properly.
- 



### NOTE

If installing the battery with the optional conduit box, secure the conduit fittings to the enclosure using the counter nuts after step 2.

---

3. If applicable, route the battery power cables through the conduit box to the inverter **without making any connections!**
  4. Ensure proper polarity of cables. Once confirmed, proceed to the next step.
  5. Install the positive battery cable to the inverter's positive battery terminal following proper torque values. See table below.
  6. Install the negative battery cable to the inverter's negative battery terminal following proper torque values. See table below.
- 



### CAUTION

**Do not disassemble the battery.** Contact the distributor for any issues that need repair for more information and proper handling instructions. Incorrect servicing or re-assembly may result in a risk of electric shock or fire, and void the warranty.

---

## 10.7 MULTIPLE INVERTER PARALLEL INSTALL

### NOTE

The steps below apply to both the 12kPV and 18kPV inverters.

The hybrid inverter supports parallel connection to expand power and energy capacity to suit different usage scenarios. **Up to 10 units can be paralleled to reach a capacity of 120kW, using the 18kPV and 80kW, if using the 12kPV inverters.**

The parallel wiring diagrams are as follows. The manual bypass switch connects the loads to LOAD panel as default. If the inverters fail, users can switch the loads to utility. **Contact the inverter supplier for more detailed guidance on paralleling the system.**

### NOTICE

Set the CAN communication pin to ON for the first and last inverter and OFF for the inverters in between. Both switches in the "ON" position translates to address 1, and both switches "OFF" translates to address 0.

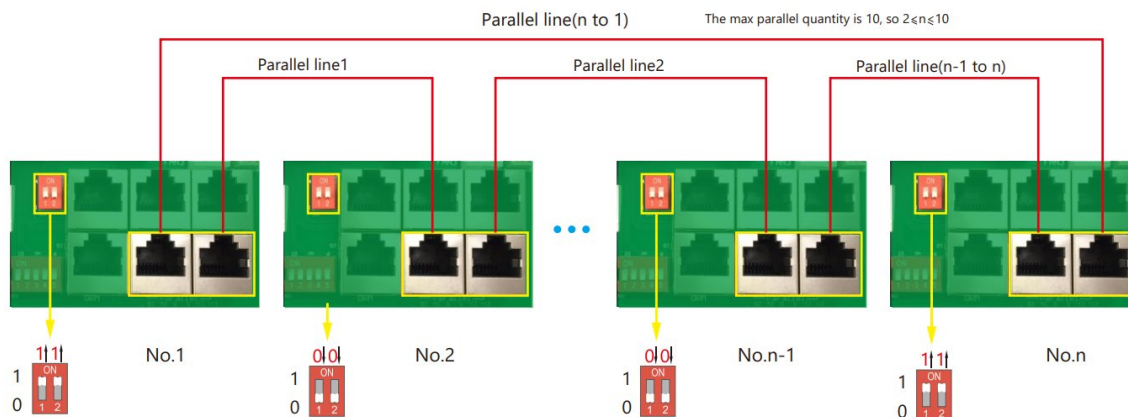

#### Important notices for parallel system:

- If utilizing the Generator input (GEN), ensure that the generator is connected to all inverters in parallel.
- If it is not possible to evenly divide solar strings per inverter, it is recommended to have more PV strings on the master inverter.
- The values shown on the LCD of each inverter display the individual inverter's contribution to the system, **not the system's total**.



## NOTICE

If needing to extend the inverter to inverter paralleling cable, confirm the cable is a straight-through CAT5 cable or higher. See image below for reference.

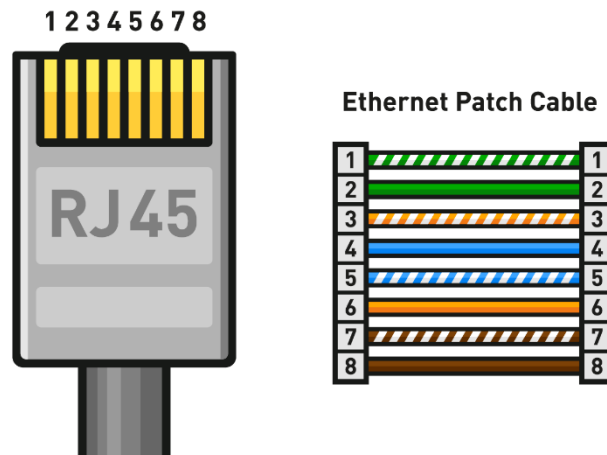

### Before commissioning:

1. Verify that all inverters in the system are updated to the latest firmware. Contact the distributor to confirm the latest version.
2. Make sure the power cables and parallel communications cables have been properly connected and verify the DIP-switch settings are correct.
3. If using battery power, close (turn on) the battery breaker and then begin powering batteries on one by one to provide power to the inverter, If using AC power, close the GRID breaker to power on the inverter.
4. Set the system to standby via the “**Basic**” page in the settings.
5. Verify that the inverter status is set to “**0.**”
6. Select which unit will be the Master by selecting “**1 phase master**” in Advanced Settings. Set all others to “**Slave.**”
7. Ensure all inverters are set to “**R**” phase.
8. For closed-loop communications, enable “**Share Battery**” setting for all paralleled inverters.
9. Ensure the battery to inverter communications cable is properly connected from master battery to the master inverter.

### Commissioning steps:

1. Turn on the battery and make sure the communication works on all units.
2. Check the parallel info via the Home page.
3. Turn on the “**Off-grid output**” function in the “**Advanced**” page.
4. Before connecting load to load output terminal, check the output of L1 to N (120V in the U.S.), L2 to N (120V in the U.S.) and L1 to L2 (240V in the U.S.).
5. Add some small loads to the load output and verify power output.

## 10.8 MULTIPLE BATTERY PARALLEL INSTALL

When paralleling multiple batteries, a paralleling kit must be purchased through the distributor. Follow the steps outlined below to ensure proper installation of multiple batteries in parallel.

### NOTE

When installing multiple batteries, please ensure all batteries are charged to 100% before paralleling together. This step is crucial for optimizing battery performance and ensuring proper operation.

1. Verify all circuit breakers are open (off). Using a multimeter, check for voltage at all available disconnects and lines. Once no voltage is confirmed, proceed to the next step.
2. Set the address code of each battery according to the DIP Switch ID Table, make sure there are no duplicate addresses.
3. Set up communication between the batteries via the “*Battery-Comm*” ports of each battery. Use the paralleling kit communication cable to daisy chain all paralleled batteries in the bank together. See diagram below for example.
4. The battery with DIP Switch ID 1 (referred to as the master) connects to the inverter via a properly pinned communication cable using the RS485/CAN port.
5. Install battery paralleling cables between batteries. See image below.

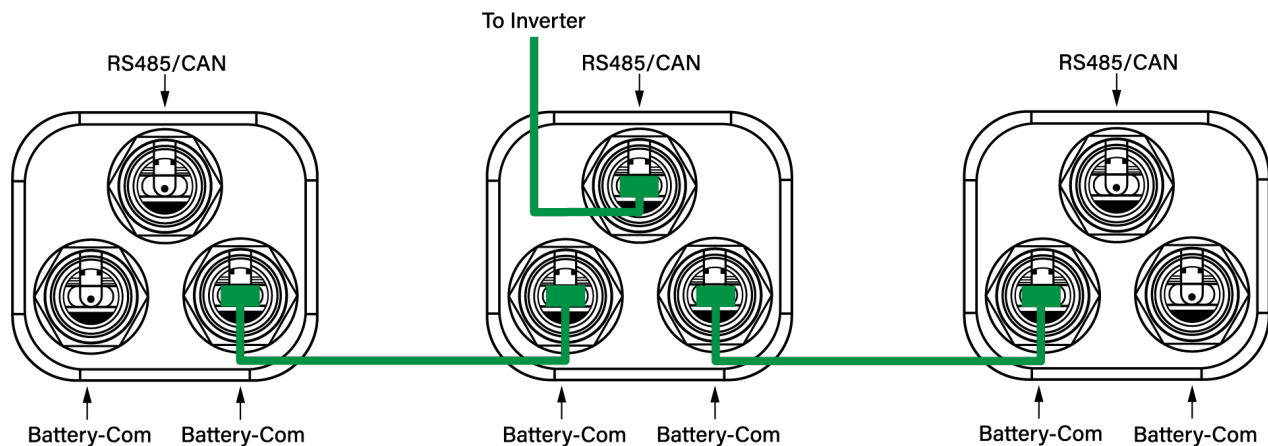

## 10.9 BMS COMMUNICATIONS

EG4 batteries interface with compatible inverters by designating a “Master” battery (DIP switch ID No. 1).

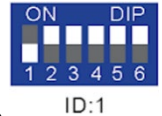

The battery will connect directly to the inverter via an RS485 battery communications cable or a standard CAT 5, 5e, or 6 cable for closed loop communications with supported EG4 and non-EG4 inverters using CAN bus protocol.

The PC software “BMS TOOLS” provides real-time battery analysis and diagnostics. The battery cannot communicate with the software and a closed loop inverter simultaneously.

Scan the QR code on the left for a video walking through the BMS Tools setup process.

Scan the QR code on the right for a white sheet walking through the BMS



































































### WARNING

Make sure to install the communication cables into their respective ports. Improper installation may lead to component damage.

EG4 recommends double checking all points of connection before introducing power to the system to mitigate potential issues.

## 10.10 DIP SWITCH ID TABLE

If paralleling multiple batteries, all DIP switch settings **must** be different from each other. This allows all equipment to see each battery in the bank separately. For best practice, place IDs in sequence starting with ID 1 as the master battery.

 ID:1	 ID:2	 ID:3	 ID:4	 ID:5	 ID:6	 ID:7	 ID:8
 ID:9	 ID:10	 ID:11	 ID:12	 ID:13	 ID:14	 ID:15	 ID:16
 ID:17	 ID:18	 ID:19	 ID:20	 ID:21	 ID:22	 ID:23	 ID:24
 ID:25	 ID:26	 ID:27	 ID:28	 ID:29	 ID:30	 ID:31	 ID:32
 ID:33	 ID:34	 ID:35	 ID:36	 ID:37	 ID:38	 ID:39	 ID:40
 ID:41	 ID:42	 ID:43	 ID:44	 ID:45	 ID:46	 ID:47	 ID:48
 ID:49	 ID:50	 ID:51	 ID:52	 ID:53	 ID:54	 ID:55	 ID:56
 ID:57	 ID:58	 ID:59	 ID:60	 ID:61	 ID:62	 ID:63	 ID:64

## 11. WALLMOUNT 280AH AW LCD SCREEN

Each module has a built-in HD LCD touch screen used to display important information about the cells including voltage, current, temperature, SOC, among others.

### Button Description

There are 4 function buttons below the display with detailed descriptions, as shown in the table below.

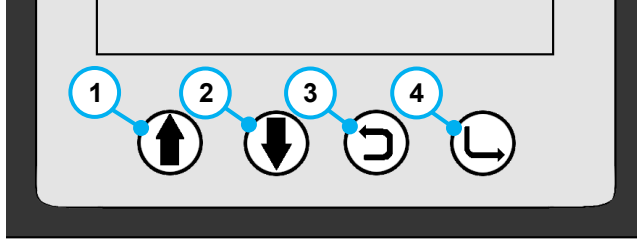

Number	Description
1	Up
2	Down
3	Return
4	Enter

### Waking up the LCD screen

Press any key to wake up the screen when the power is on, and the information will be shown on the display.

Number	Description
1	Battery Name
2	Status
3	Voltage
4	Current
5	System Date & Time
6	State of Charge

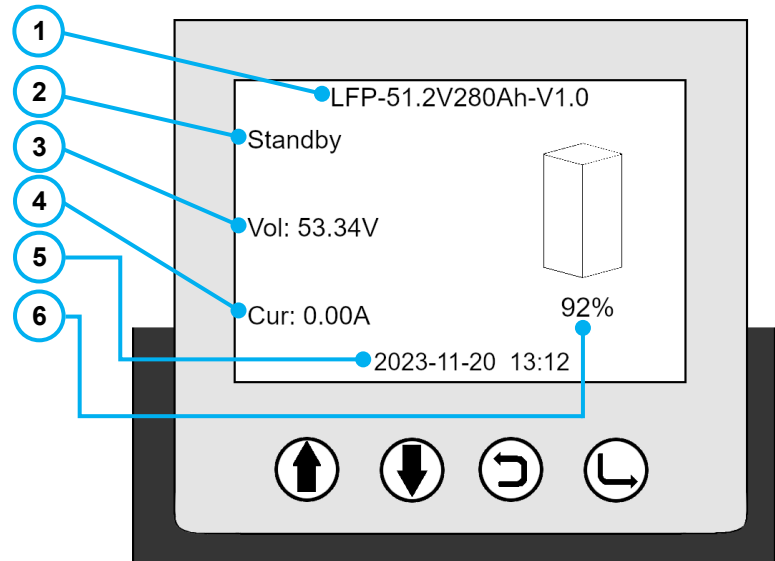

Press "Enter" on the Cell Voltage page to view the temperature information of the PCB and individual cells (shown in °C)

Temperature			
PCB Temp: 32°C			
Cell Temp:			
31°C	31°C	31°C	30°C

## 11.1 COMMUNICATION PROTOCOL SELECTION



### NOTE

Only the master battery should be set to the inverter protocol. All other batteries must have unique addresses starting at address 2 and ascending in chronological order.

Page 1

Cell Voltage(mV)		
1:3332	2:3300	3:3333
4:3334	5:3333	6:3334
7:3333	8:3334	9:3333

Page 2

Cell Voltage(mV)		
10:3332	11:3300	12:3333
13:3334	14:3333	15:3334
16:3334		

Check individual cell voltage by pressing the “Enter” button on the main page of the LCD screen (shown in mV). There are 2 pages. Pressing “Up” and “Down” changes the page.

### Protocol Change/Selection Procedure

1. Power off all battery DC breakers and BMS power buttons.
2. The inverter protocol can only be changed with the master battery temporarily set to address 64 (all switches ON. After the dipswitch is changed, restart the battery (with only the BMS power button) for the settings to take effect. (See image on right.)
3. On the master battery, press and hold the “Return”  key for 5 seconds and release to enter the “Protocol Setting” menu.



- Select the corresponding RS485 program or CAN program, and press Enter.

RS485 Protocol - P01	
P01-EG4	▲
P02-GRW	
P03-LUX	
P04-SCH	
	▼

CAN Protocol - P01	
EG4/LUX	▲
P02-GRW	
P03-SLK	
P04-DY	
P05-MGR	
P06-VCT	
P07-LUX	
P08-SMA	
	▼

Protocol #	Manufacturer
P01-EG4	EG4
P02-GRW	Growatt
P03-LUX	Luxpower
P04-SCH	Schneider

Protocol #	Manufacturer
P01-EG4/LUX	EG4/LUX
P02-GRW	Growatt
P03-SLK	Sol-Ark
P04-DY	Deye
P05-MGR	Megarevo
P06-VCT	Victron
P07-LUX	Luxpower
P08-SMA	SMA

- Press the “Return”  key to return to the main interface.
- Change the master DIP switch address back to address 1. (See image on right.)
- Power cycle the master battery, and the BMS will correspond to the protocol selected.



## “About” Screen

When single tapping the battery’s return key, the “About” page will populate. Here the user can check which Inverter protocol the battery is set to, BMS version numbers, and Firmware version numbers.

See image to the right for an example.

About
Protocol: RS485: P01-EG4 CAN: EG4/LUX
Version: BMS: Z02T10 LCD: V1.1.0

## 12. EG4<sup>®</sup> MONITOR CENTER



### NOTE

The monitoring system may change due to updates. Therefore, UI descriptions may vary from the current pages on the site. If you have any questions, or to create distributor/installer accounts, contact [support@eg4electronics.com](mailto:support@eg4electronics.com) for assistance.

### USING EG4<sup>®</sup> MONITOR CENTER

1. Using a web browser, connect to “monitor.eg4electronics.com” and select on “Register”.
2. Complete the online form. Contact the distributor for the customer code. The dongle serial number (SN) and dongle PIN can be found on the sticker attached to the side of the dongle.
3. Once the registration is complete, return to the EG4 Monitor Center web page and login using the username and password created during the registration process.

Scan the code for additional information regarding the EG4 Monitor Center:

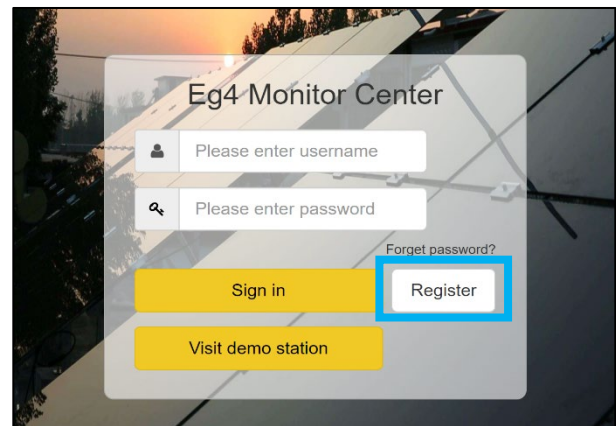

### USING THE PHONE APP

1. Download the “EG4 Monitor” app for iOS or Android. After installation is complete, open the app.
2. Select “Register,” then complete the required information and press “Register”. Contact the distributor for the installer code.
3. Once the registration is complete, return to the login page and login using the username and password created during the registration process.

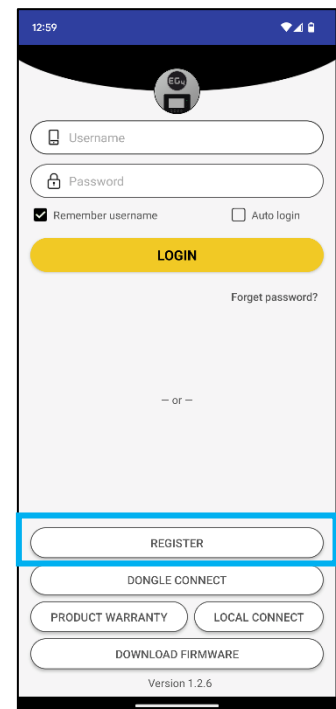

## 12.1 EXISTING USER ACCOUNT

When an EG4® account already exists, new EG4 hardware that utilizes a dongle can be added to the existing account. This can be completed using the Monitor Center or the phone app.

### USING EG4 MONITOR CENTER:

1. Using a web browser, open “monitor.eg4electronics.com” and login with the existing username and password.
2. Navigate to the “Configuration” tab, then select “Dongles.”
3. Select “Add Dongle.”
4. Enter the new dongle serial number and pin, select the station to assign the dongle to, then click” Add.”
5. The EG4® FlexBOSS18 should now be available in Monitor Center.

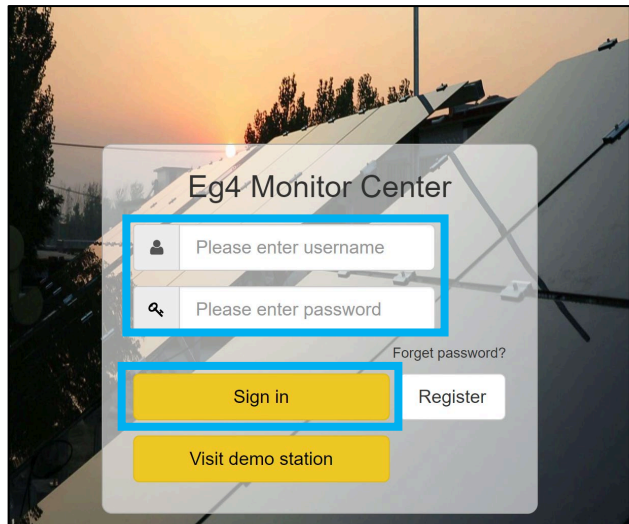

### USING THE PHONE APP:

1. Open the “EG4 Monitor” app and login using an existing name and password.
2. Select the back arrow in the upper left corner of the screen.
3. Select “Add Dongle.” Scan or enter the dongle information located on the dongle sticker, then press “Add Dongle.”

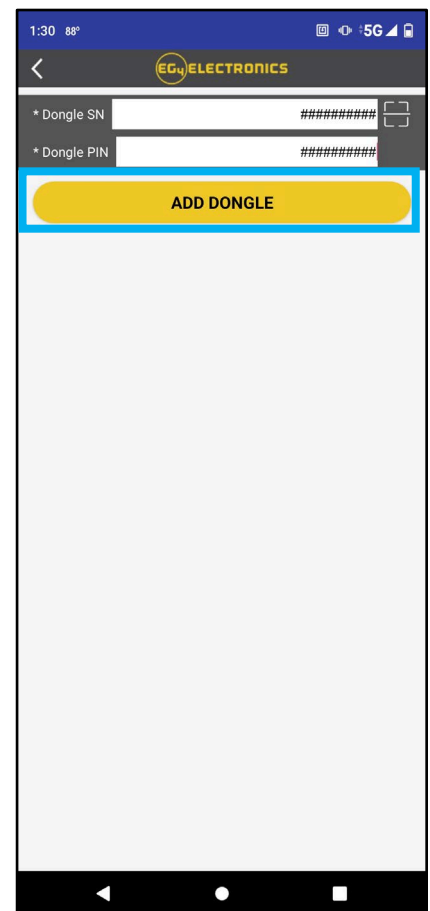
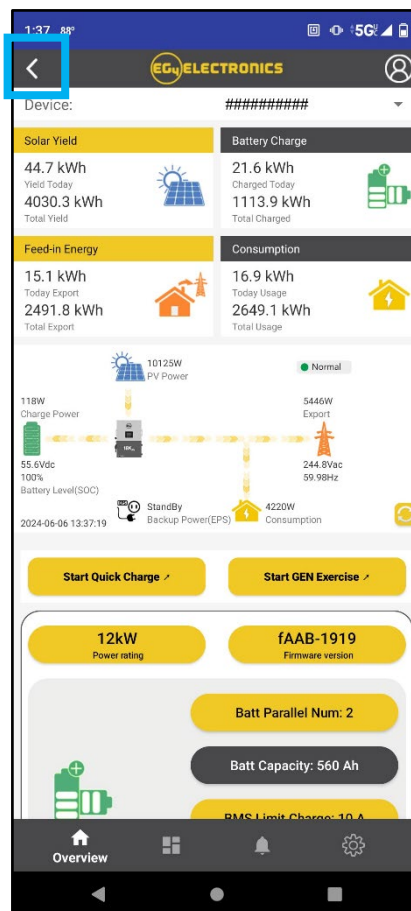
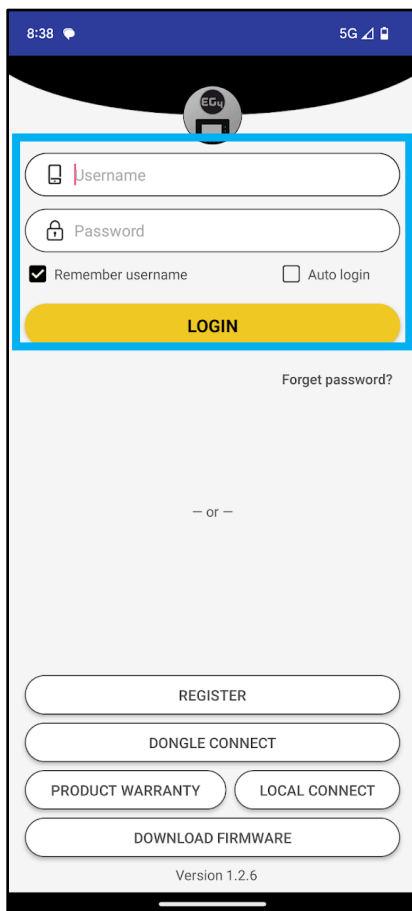

## 12.2 ENABLE APP NOTIFICATIONS

The EG4® Mobile App allows the end user to easily check real-time system information regarding the inverters, batteries, and other informative values.

### ENABLE NOTIFICATIONS IN MONITOR CENTER:

1. Go to monitor.eg4electronics.com and login.

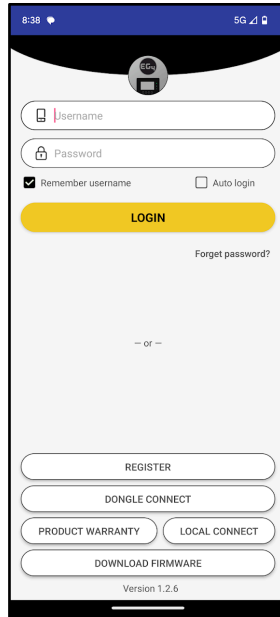

2. At the top of the screen, select “Configuration,” then “Users.”

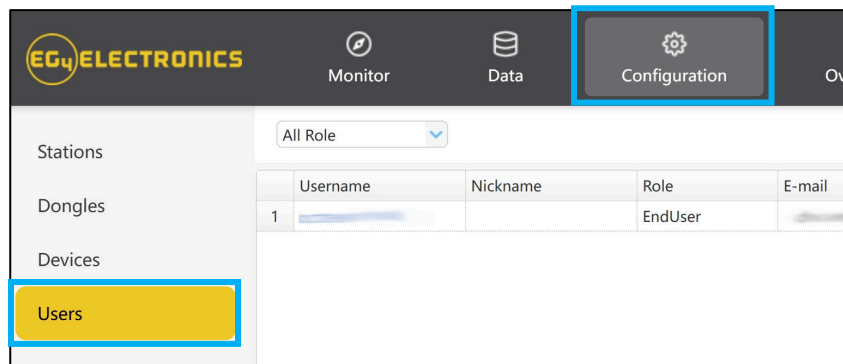

3. Select “User Management,” then “APP Notice.”

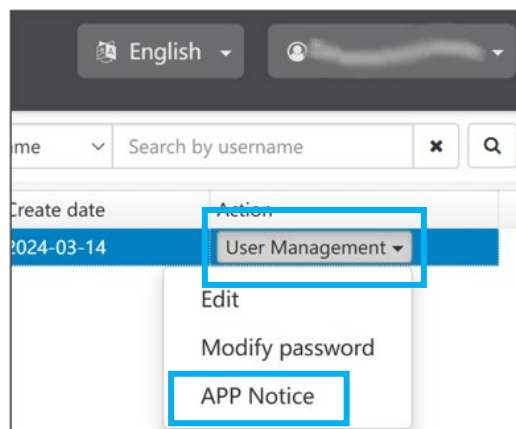

- Choose which setting to enable, and what values will trigger a notification. Select “Edit.”

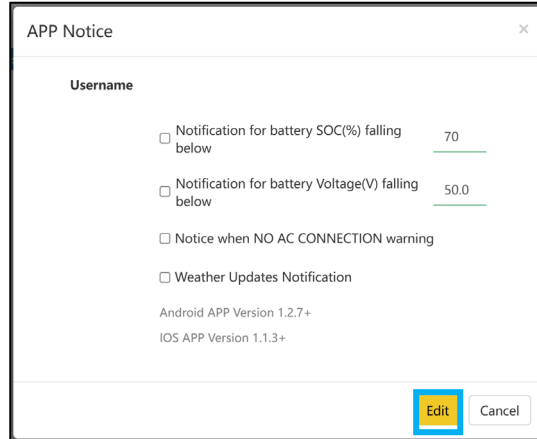

## ENABLE NOTIFICATIONS ON A MOBILE DEVICE:

The EG4® Mobile App allows the end-user to easily check real-time system information regarding the inverters, batteries, and other informative values.



Verify the app is up to date before proceeding!

- Login to the EG4® Monitor App. Select the user icon at the top right corner of the screen.

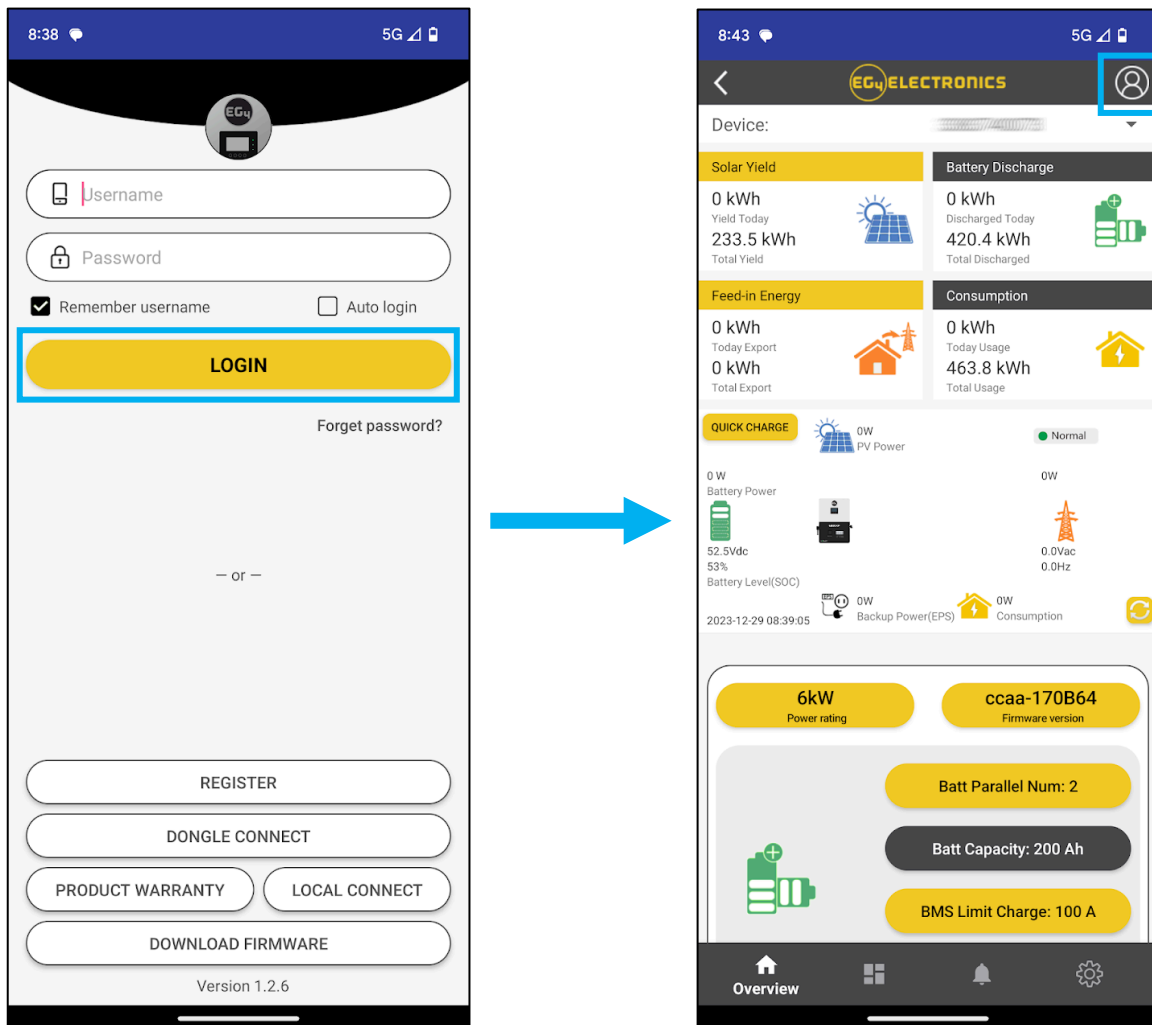

2. Select “Notifications,” “Allow Notifications,” and make selections for which notifications to receive. Toggle selection on to “Allow Notifications” on device and choose how to receive notifications

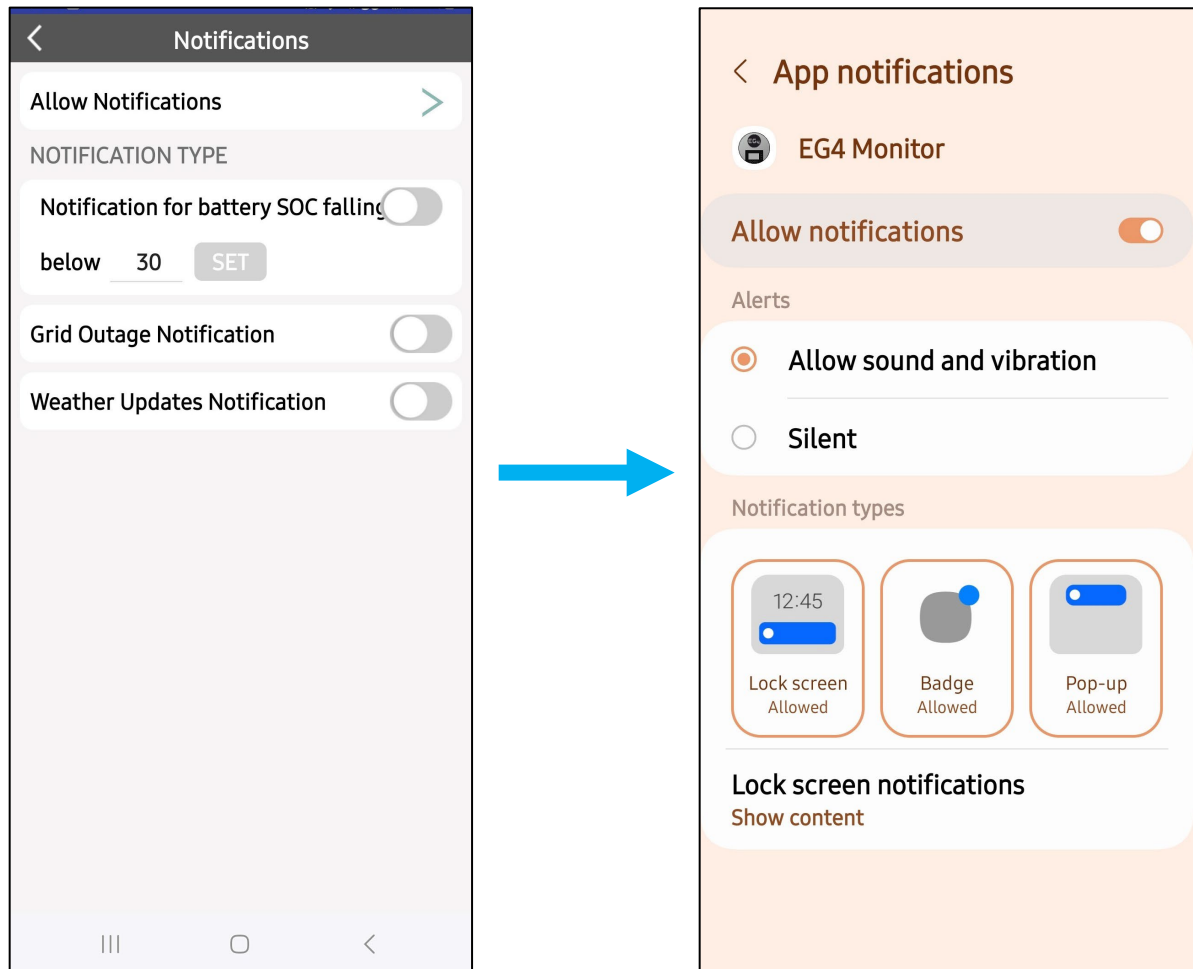

## 12.3 LOCAL MONITORING SETUP WITH THE EG4® MONITORING APP

If there is no Wi-Fi available at the location, use the local function to monitor or set up the system:

1. Download the EG4® Monitor app.
2. Connect the mobile device to the dongle’s Wi-Fi hotspot after the INV LED on the Wi-Fi module is solid on. The name of the hotspot is the same as the serial number on the Wi-Fi module shell.
3. Select “Local Connect.” Now the system can be monitored and set up either through the hotspot connection or Bluetooth (on Android devices only).

## 13. DONGLE INSTALLATION

A Wi-Fi/4G dongle can be used to monitor the inverter and remotely view the monitoring data on a computer or smart phone. Attach this module by plugging it in to the side of the inverter and securing it with the four (4) Phillips head screws (see image below).

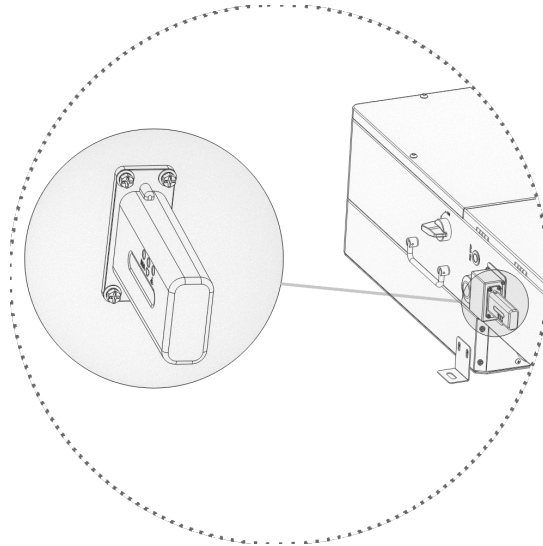

### 13.1 CONNECTIVITY REQUIREMENTS

Due to certain limitations of the Wi-Fi Dongle, please ensure that the home Wi-Fi network signal and security settings meet the following requirements:

- The Wi-Fi dongle only supports wireless networks in the 2.4GHz frequency band. If the router supports the 5GHz or 6GHz network frequencies, please confirm the router supports the 2.4GHz network frequency band and it is enabled.
- The Wi-Fi dongle is compatible with WPA1, WPA2, and WPA3 security protocols on the 2.4GHz network only.
- Ensure the Wi-Fi dongle can obtain an IP address by verifying the home Wi-Fi router has DHCP (Dynamic Host Configuration Protocol) setup and it is enabled.
- It is recommended the home Wi-Fi network name length does not exceed 19 characters, and the password length does not exceed 24 characters. It is *not* recommended to use any of the following special symbols in the password: @, #, \$, %, &, \*, ?, \_, /, or using a space “keyboard spacebar”.

## 13.2 DONGLE PARAMETERS

The dongle network parameters can be used for troubleshooting various configuration and connectivity issues. This section describes the steps to view the dongle parameters along with a brief description for each parameter.

1. Verify the Wi-Fi LED is solid on. If the LED is not on, see section 17.5.
2. Using an iOS or Android device, connect to the Wi-Fi network created by the dongle, generally it's named as dongle serial number (i.e., BEXXXXXXXX, BJXXXXXXXX, BGXXXXXXXX).

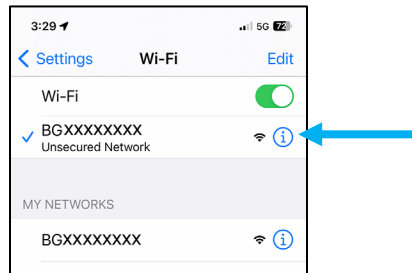

3. Open the EG4 app and select Dongle Connect. Then select Dongle Connect Params.

**NOTE:** If the home screen is bypassed after opening the EG4 app, click the user icon in the upper right of the screen and then select logout.

**NOTE:** After clicking Dongle Connect, give the dongle time to respond to the EG4 monitor phone app. This could take up to 60 seconds based on connectivity strength.

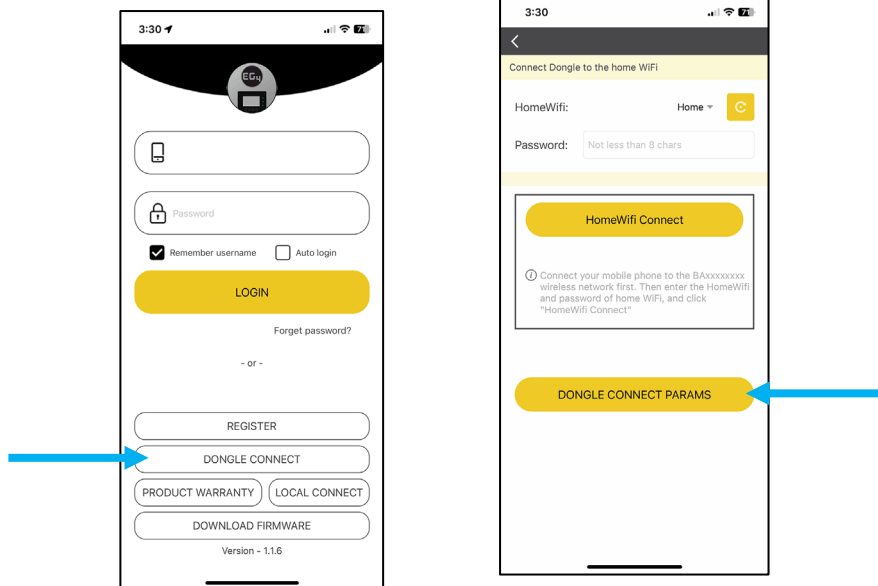

4. The configuration parameters used by the dongle when connecting and communicating over the Wi-Fi network are described below:

<b>AP State</b>	
Function	Enable
Ip	10.10.10.1
Netmask	255.255.255.0
<b>STA State</b>	
Function	Enable
Ip	192.168.1.74
Netmask	255.255.255.0
Gateway	192.168.1.1
<b>AP Parameter</b>	
SSID	BGXXXXXXX
Encryption Mode	<input type="checkbox"/>
AP Password	<input type="password"/>
Restart Dongle	<input type="button" value="SET"/>
<b>Station Parameter</b>	
SSID	Home
Password	<input type="password"/>
Connection State	Connected
<b>Network 1 State</b>	
Protocol	TCPClient
Remote Port	3.101.7.137
Server Address(Ip or domain)	4346
TCP Client State	Connected
<b>Network 2 State</b>	
Protocol	TCPServer
Local Port	8000

This is the dongle's IP address of the when it is acting as the access point to other Wi-Fi devices (i.e. phones, tablets, etc). This is also the gateway address attached devices use when communicating to the dongle via Wi-Fi. The dongle IP address 10.10.10.1/24 is pre-set at the factory and will always be the same.

This is the DHCP IP address the dongle received from the home Wi-Fi network. The gateway listed here is the IP address of the home Wi-Fi router. If the user knows the home Wi-Fi router password, the gateway address can be used to connect to the router if network parameters need to be changed. If the STA State area does not populate with an IP address, the dongle is not properly connecting to the home Wi-Fi router (network).

This area displays encryption information for the dongle's Wi-Fi network, including the SSID of the dongle, if encryption mode is enabled or disabled, the encryption password, and a button to restart the dongle. Enabling encryption mode provides a level of security when connecting a device directly to the dongle. By default, any device can connect to the dongle without requiring a password (no security).

The SSID of the home Wi-Fi network, password, and connection state.

The protocol and address used to communicate with the EG4 monitoring server over the internet.

Protocol and port used for internal communication between dongle and inverter.

## 13.3 LED INDICATORS AND BUTTON FUNCTIONALITY

**LEDs:** Each of the three LEDs on the dongle will illuminate green once that step in the boot/configuration process is complete.

1. **Wi-Fi LED:** Dongle has power, and the Wi-Fi hotspot is on.
2. **Cloud LED:** Dongle is communicating with the monitoring server.
3. **INV LED:** Dongle to inverter communication is established and functioning.

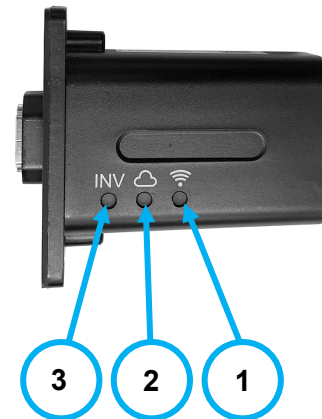

**Bottom Button:** When using dongle firmware version 2.0 or later, press the button on the bottom of the dongle to perform the following:

- Reboot the dongle - Hold down the button for 5 seconds, then release.
- Disable encryption - Hold down the button for 10 seconds, then release.

### NOTE

Use a small Phillips screwdriver or similar object to press the button to ensure the button is pressed far enough to register the input. The dongle will not reboot until the button is depressed.

## 13.4 DONGLE BOOTUP STEPS

The following steps describe the Wi-Fi dongle bootup sequence:

1. After the Wi-Fi Dongle receives power from the inverter and completes the first step in the bootup process, the Wi-Fi LED should be on. The dongle then creates a hotspot (see image) for supported devices to connect to.

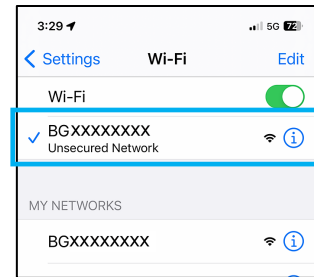

**NOTE:** The dongle should automatically power-on if the inverter is on and the dongle is plugged into the dongle connector. If the Wi-Fi LED is not on, check the physical connection to ensure the dongle is completely seated into the connector on the inverter. The dongle is hot-pluggable, meaning it can be removed and re-inserted with the inverter on.

2. Once the dongle is properly configured, it should successfully connect to the home Wi-Fi network and then to the internet. The Cloud LED will illuminate once the dongle connects to the monitoring server via the internet.
3. Once the dongle has a connection to the monitoring server, it will then set up an internal connection to the inverter. When internal communication is successful, **the INV LED is solid on.**
4. When all three dongle LEDs are on, the inverter can be configured and monitored using the EG4 monitor phone app or the EG4 monitor website.

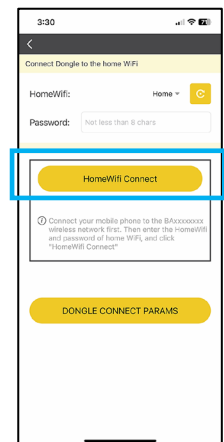
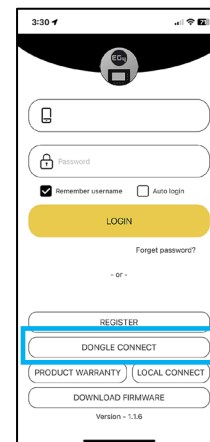

## 14. ESS STARTUP & SHUTDOWN

### ESS STARTUP

1. Before proceeding, make sure proper PPE is equipped.
2. Before powering the inverter and battery, verify that the system is ready to be powered on:
  - a. Ensure all connections are properly tightened.
  - b. Ensure all circuit breakers are in the open (OFF) position.
  - c. Using a multimeter, check the battery bank to ensure no voltage (DC) is present.
  - d. Check the external PV isolator switch via multimeter to ensure the voltage (DC) is in the MPPT's optimal operating range.
  - e. If utilizing AC input, double check each hot line to neutral coming into the inverter to ensure voltage is in operating range of the unit.
3. Upon confirming all voltages are within the inverter's operating range, close the battery breaker on the front of the inverter.
  - f. Close the external battery breaker between bank and inverter (if equipped).
4. Begin powering on batteries one at a time, starting with the master, in ~5 second intervals.
  - g. Press the BMS power switch located under the breaker on the right-hand when facing the battery from the front.
  - h. Pull the cover of the battery breaker upward. While holding the cover open, flip the battery breaker up to power on the battery.
  - i. The battery screen will power on. Release the cover and close.
5. Close the external PV isolator switch (if equipped).

6. Close PV breaker on the side of the unit.
7. If using AC input, close the external breaker between panel and inverter.
8. Close the GRID breaker on the front of the inverter.
9. Power on the inverter via the power switch on the side of the unit.
10. Close external AC output breaker (if equipped) going to the panel.
11. Turn ON the EPS Output (AC Output) switch on the side of the unit to begin powering loads.



## DANGER

**Never disconnect battery, PV, or AC power while under loads.** If there is an emergency and users must shut down the inverter, please follow the steps outlined in this section.

---

### ESS SHUTDOWN

1. Turn ON the EPS output on the side of the inverter.
2. Open the LOAD breaker on the front of the inverter.
  - a. Open external AC output breaker if equipped.
3. Open the GRID/GENERATOR breaker on the front of the inverter.
4. Open the external PV isolator switch.
5. Open the PV breaker on the side of the inverter.
6. Open the battery breaker on the front of the inverter.
  - a. Open the external battery breaker if equipped.
7. Power down the batteries one at a time starting with the master.
  - a. Press the BMS communications button located under the breaker on the right-hand side when facing the battery from the front.
  - b. Pull the cover of the battery breaker upward. While holding the cover open, flip the battery breaker down (off) to power off the battery.
  - c. The battery screen will power down. Release the cover and close.
8. Turn the power switch on the side of the inverter to off.



## NOTE

The dongle will power down when no power is supplied to the inverter.

---

## 15. INVERTER WORKING MODES

### 15.1 18KPV MODES

#### Time of Use:

Time of use is a setting that is applicable to numerous scenarios to maximize cost savings by adjusting the battery's usage patterns. It enables the system to meet energy demands across different time periods, provide real-time system status, and provide detailed reports. This feature is customizable for fluctuations in electricity prices and to individual needs.

To enable this feature, select "Maintenance" at the top of the Monitor Center Webpage. Select "Weather Optimization" to the left of the screen. Select the desired inverter and select the location button. Input the inverter's information on the next screen. Afterwards, enable the times of use for battery charging/discharging under the "Maintenance" tab.

The screenshot shows the EG4 Monitor Center Webpage interface. The top navigation bar includes 'Monitor', 'Data', 'Configuration', 'Overview', and 'Maintenance' (highlighted). Below the navigation bar, there is a 'Remote Set' section with an 'Add device' button and a search bar. A yellow button labeled 'Weather Optimize' is highlighted. Below this, a table lists two inverters with columns for 'Serial number', 'Station name', 'Charge Time Range', 'Location', and 'Action'. The 'Location' column for both inverters shows a location icon, which is highlighted with a blue box. The 'Action' column shows a 'Management' dropdown menu.

Serial number	Station name	Charge Time Range	Location	Action
1		00:30 - 04:00	✓	Management
2		00:30 - 04:00	✓	Management

#### Weather Optimize Function:

Used to collect real-time weather data to automatically adjust the state of charge. This maximizes the efficient use of solar energy by ensuring the battery bank remains adequately charged for stable electricity consumption. "Charge Priority Mode" prioritizes battery charging to ensure stable electricity usage, making it ideal for areas with unstable power supply. "Self-Consumption Mode" prioritizes self-generated solar power to meet household electricity demands, making it ideal for areas with high electricity prices. "Forced Charge/Discharge Mode" chooses to charge or discharge batteries based on electricity pricing, making it ideal for time-of-use pricing areas.

This screenshot is identical to the one above, showing the EG4 Monitor Center Webpage interface with the 'Maintenance' tab selected and the 'Weather Optimize' function highlighted. The table below shows the configuration for two inverters.

Serial number	Station name	Charge Time Range	Location	Action
1		00:30 - 04:00	✓	Management
2		00:30 - 04:00	✓	Management

- To enable this feature, select “Maintenance” at the top of the Monitor Center Webpage. Select “Weather Optimization” to the left of the screen. Select the desired inverter and select the location button.

A screenshot of a web form for selecting location information. The form includes the following fields and options:

- \* Station name: A text input field with a checkmark icon on the right.
- LNG-LAT: A text input field with a location pin icon on the right.
- \* Create time: A text input field.
- \* Continent: A dropdown menu with "North America" selected.
- \* Region: A dropdown menu with "North America" selected.
- \* Country: A dropdown menu with "United States of America" selected.
- \* Timezone: A dropdown menu with "GMT -6" selected.
- \* Daylight saving time: Radio buttons for "Yes" and "No", with "No" selected.

At the bottom of the form are three buttons: "Update", "Export", and "Cancel".

- Input the inverter’s information and select “Update”.

- Afterwards, select “Management” and click “Edit”. Here, users can set charging times and percentages based on their electricity use patterns and weather conditions. The platform sends user settings to the inverter, and the inverter provides feedback, confirming the receipt of setting and executing charging operations according to user-defined parameters.

A screenshot of a web form for managing inverter settings. The form includes the following fields and options:

- \* Serial number: A text input field.
- \* Charge Start Time: A dropdown menu with "00:00" selected.
- \* Charge End Time: A dropdown menu with "00:00" selected. A blue tooltip message reads: "May not charge when end time is equal with start time".
- Charge percent(%) by weather: A section with multiple rows, each containing a weather condition and a corresponding text input field for the percentage:
  - \* Clear sky: Clear sky
  - \* Few(11%-25%) clouds: Few(11%-25%) clouds
  - \* Scattered(25%-50%) clouds: Scattered(25%-50%) clouds
  - \* Broken(51%-84%) clouds: Broken(51%-84%) clouds
  - \* Overcast(85%-100%) clouds: Overcast(85%-100%) clouds
  - \* Light rain: Light rain
  - \* Moderate rain: Moderate rain
  - \* Heavy rain: Heavy rain
  - \* Other: Other

At the bottom right of the form are two buttons: "Edit" (highlighted in yellow) and "Cancel".

## Working Modes:

Working modes are pre-set priority systems that allow users to configure the system to meet their demands through extensive customizations. These modes can be found under the Maintenance tab by selecting “Working Mode.” Scroll past “Application Setting” to the “Working Mode Setting” section.



### Working Mode Definitions:

- **Backup Mode:** Used to save battery power as a last resort. The solar arrays power the loads, and when PV is insufficient, loads will pull from the grid. The inverter will only power loads with battery when there are no other options.
- **Peak Shaving:** Used to avoid peak demand charges from the grid by using a combination of settings to limit the power drawn from the grid.
- **AC Charge Mode:** Used to charge battery bank with the grid while loads are supported by PV. Batteries can then be used when electricity prices are high.
- **PV Charge Priority:** Used to charge battery bank with PV; once battery bank is charged, then PV will be used to power loads.
- **Forced Discharge/Export PV Only:** Used to sell PV and/or battery power back to the grid.
- **Self-Consumption:** Used to significantly lower grid consumption. Solar arrays power loads, then, when PV is insufficient, batteries power loads, and AC is only used as a last resort.

## Backup Mode

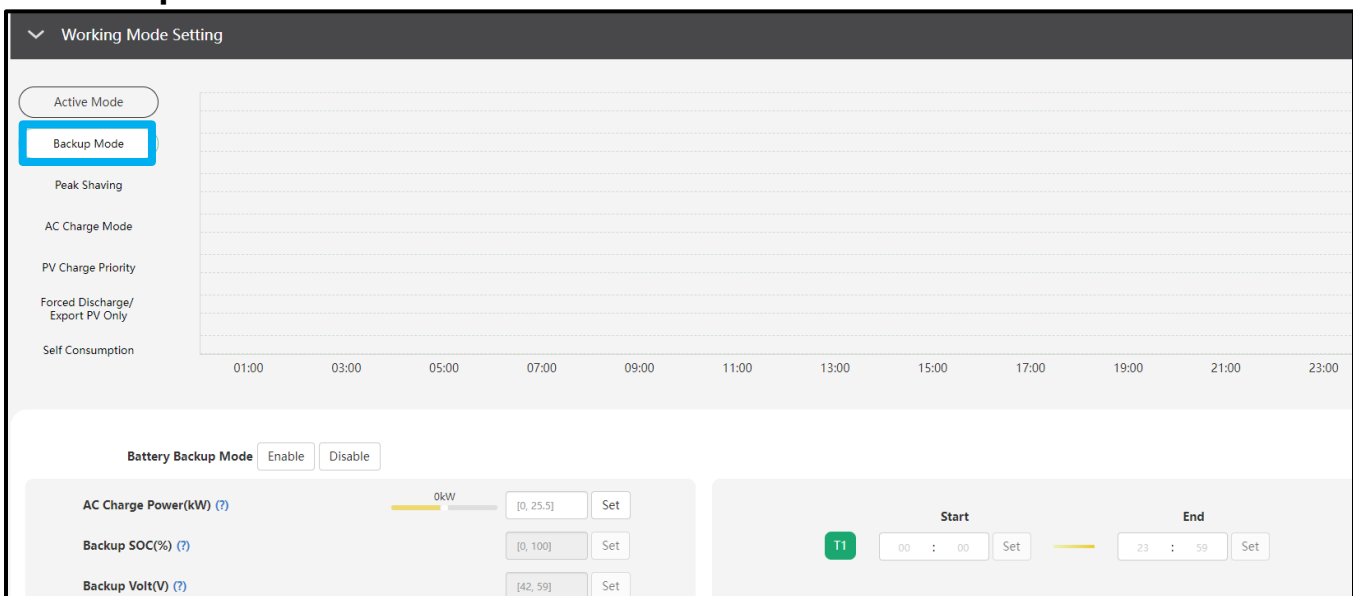

When setting the station in this mode, the inverter will use batteries as a last resort. The user will be able to configure the system to set how much power is drawn from the grid; at what percentage, voltage, and time to stop and start charging.

Upon selecting the working mode, the system must be configured using the settings listed below:

- **Battery Backup Mode:** “Enable” “Battery Backup Mode”.
- **AC Charge Power(kW):** Set the maximum amount of power to draw from the grid.
- **Backup SOC (%) / Volt (V):** Percentage or voltage at which the system will stop charging batteries from the grid.
- **T1 Start/ T1 End:** Set the start and end time of charging.

## Peak Shaving:

The screenshot displays the 'Working Mode Setting' interface. On the left sidebar, 'Peak Shaving' is highlighted with a blue box. The main area features a graph with a grid showing power consumption over a 24-hour period. Below the graph, the 'Grid Peak-Shaving' toggle is set to 'Enable'. The configuration section is divided into two columns for two battery banks, T1 and T2. Each column contains sliders and input fields for 'Grid Peak-Shaving Power(kW)', 'Start Peak-Shaving Volt 1(V)', and 'Start Peak-Shaving SOC 1(%)'. Below these are 'Start' and 'End' time settings for each battery bank, with T1's start time set to 08:00 and T2's to 12:00.

When setting the station into this mode, the inverter will use peak-shaving to avoid peak demand charges from the grid. The user will be able to configure the system to pull limited (or no) power from the grid by setting maximum power pulled from the grid, the SOC/voltage of the battery bank in which to start grid peak-shaving, and by setting time of use.

Upon selecting the working mode, the system must be configured using the settings listed below:

- **Grid Peak-Shaving:** “Enable” “Grid Peak-Shaving”.
- **Grid Peak-Shaving Power(kW)/Grid Peak-Shaving Power2(kW):** Set the maximum amount of power that will be drawn from the grid.
- **Start Peak-Shaving Volt 1(V)/Start Peak-Shaving Volt 2(V):** Set the starting point of peak-shaving when using voltage setpoints for batteries.
- **Start Peak-Shaving SOC 1(%) / Start Peak-Shaving SOC 2(%):** Set the starting point of peak-shaving when using SOC setpoints for batteries.
- **T1/T2 Start:** Set the start time of peak-shaving depending on SOC/voltage as configured above.
- **T1/T2 End:** Set the end time of peak-shaving depending on SOC/voltage as configured above.

## AC Charge Mode:

The screenshot displays the 'Working Mode Setting' interface for 'AC Charge Mode'. The left sidebar lists various modes, with 'AC Charge Mode' highlighted. The main area features a grid chart for monitoring. Below the chart, the 'AC Charge Enable' toggle is set to 'Enable'. The configuration section includes several parameters: 'AC Charge Power(kW)' is set to 25.5; 'AC Charge Based On' is set to '<Empty>'; 'Start AC Charge SOC(%)' is 42.59; 'Stop AC Charge SOC(%)' is 100; 'Start AC Charge Volt(V)' is 40.57; and 'Stop AC Charge Volt(V)' is 42.59. On the right, three time periods (T1, T2, T3) are defined with their respective 'Start' and 'End' times.

Users can charge battery bank with grid power when electricity prices are low, then use battery power to run loads or export to the grid when electricity prices are high. When setting the station into Backup/AC Charge mode, the user can configure the system to prioritize charging batteries from grid power. The user can configure the settings to charge with grid based on maximum power in kW, SOC/voltage, or by setting times of use.

Upon selecting the working mode, the system must be configured using the settings listed below:

- **AC Charge Enable:** “Enable” the system’s ability to charge batteries from the grid.
- **AC Charge Power(kW):** Set the maximum power drawn from the grid to charge batteries.
- **AC Charge Based On (SOC/Volt/Time):** Configure how the system will charge batteries from the grid by setting custom voltage points, SOC% of batteries, or by time.
- **Start/Stop AC charge SOC (%) / Volt (V):** Percentage or voltage at which the system will start and stop charging batteries from the Grid.
- **T1/T2/T3 Start and End:** The time periods in which the system can charge the battery bank.

## PV Charge Priority:

The order of priority for solar power usage will be Battery >Load >Grid. During the “PV Charge Priority” period, loads are first supplied power from the grid. If there is excess solar power after charging batteries, the excess solar will power the loads along with grid power. Upon selecting the working mode, the system must be configured using the settings listed below:

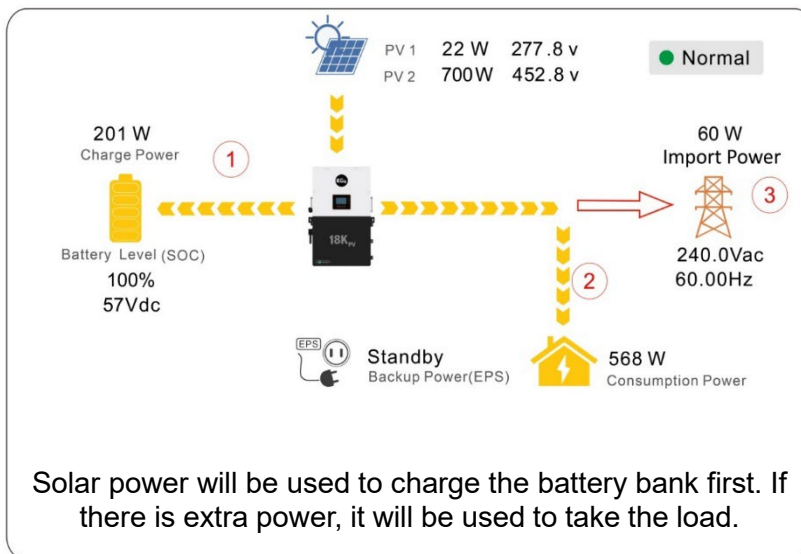

- **PV Charge Priority:** “Enable” “PV Charge Priority” working mode.
- **PV Charge Power(kW):** Set the maximum amount of power to charge the batteries from solar.
- **PV Charge Priority Stop SOC (%):** Set the stop point for “Battery Priority” according to SOC%.
- **T1/T2/T3:** Set up to 3 different start and stop times for the PV Charge Priority working mode.

## Forced Discharge/Export PV Only:

The screenshot displays the 'Working Mode Setting' interface. On the left, a sidebar lists various modes: Active Mode, Backup Mode, Peak Shaving, AC Charge Mode, PV Charge Priority, **Forced Discharge/Export PV Only** (highlighted), and Self Consumption. The main area features a time-axis from 01:00 to 23:00. Below this, there are several configuration options:

- Forced Discharge Enable (?)**: Enable/Disable buttons.
- Export PV Only (?)**: Enable/Disable buttons.
- Forced Discharge Power(kW) (?)**: Input field with value [0, 25.5] and a Set button.
- Stop Discharge SOC(%) (?)**: Input field with value [0, 100] and a Set button.
- Stop Discharge Volt(V)**: Input field with value [40, 56] and a Set button.

To the right of these settings is a scheduling table for three time periods (T1, T2, T3):

	Start	End
T1	[0, 23] : [0, 59] Set	[0, 23] : [0, 59] Set
T2	[0, 23] : [0, 59] Set	[0, 23] : [0, 59] Set
T3	[0, 23] : [0, 59] Set	[0, 23] : [0, 59] Set

When setting the station into this mode, the batteries will be forced to discharge within the set periods of time. During this period, the inverter will discharge the battery at the power set by “Forced Discharge Power(kW)” until the battery SOC or voltage set point reaches the “Stop Discharge” value.

**Note:** EG4® suggests setting this value no lower than 20% to maintain the recommended 80% Depth of Discharge (DOD).

Upon selecting the working mode, the system must be configured using the settings listed below:

- **Forced Discharge Enable:** “Enable” this setting to forcefully discharge the station’s battery bank.
- **Export PV Only:** “Enable” this setting to sell back generated PV power to the grid.
- **Forced Discharge Power(kW):** Set the maximum power limit of battery discharge.
- **Stop Discharge SOC (%):** Stop the forced discharge upon reaching the set SOC%.
- **Stop Discharge Volt(V):** Stop the forced discharge upon reaching the set voltage point.
- **T1/T2/T3:** Set up to 3 different start and stop times for the Force Discharge/Sell to Grid working mode.

## Self-Consumption:

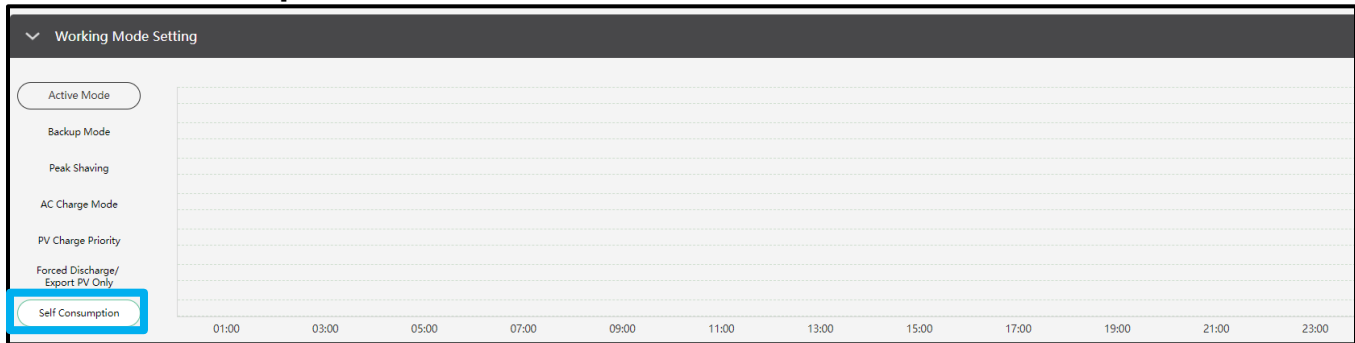

The station will default to Self-Consumption mode. The order of priority for powering loads is Solar > Battery > Grid. The order priority for solar power is Load > Battery > Grid which creates an ideal scenario when needing to prioritize solar power generation over other types of power. Self-Consumption mode will increase the self-consumption rate of solar power and reduce energy bills significantly. Effective when Charge Priority, AC Charge, and Forced Discharge are disabled.

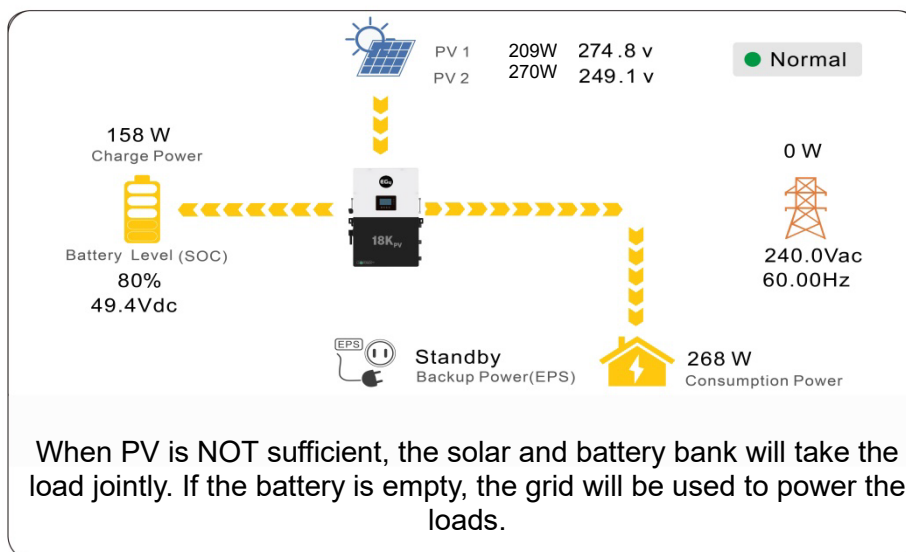
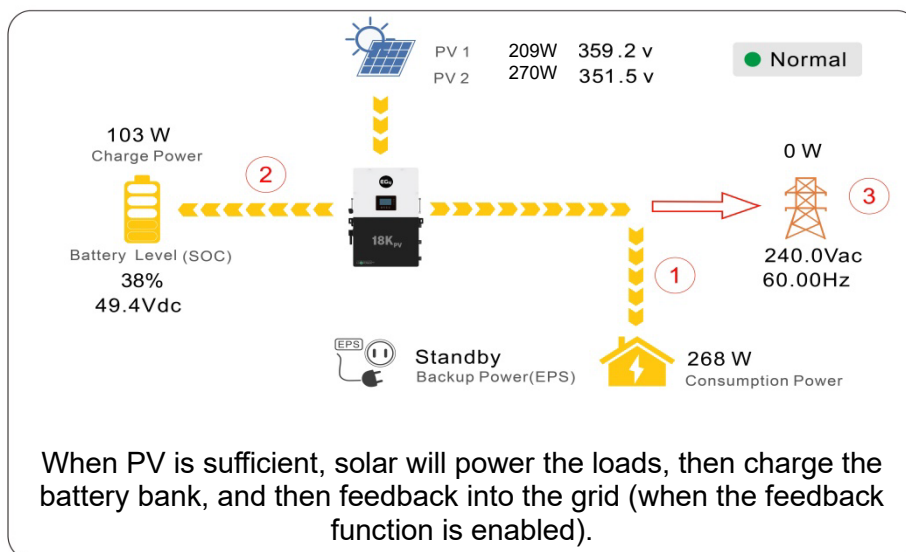

## 15.2 12KPV MODES

The EG4® 12kPV can work in several different modes of operation:

- **Self-Consumption Mode:** The inverter will operate in a pre-set priority system. In this mode, the user will experience the inverter drawing power from the solar arrays to power the loads, this is the default operating mode. When the solar power is insufficient, the inverter will then draw from the battery bank for loads. Only as a last resort will the inverter switch to bypass mode to power loads from AC input.
- **Battery Backup Mode:** The inverter will operate in a pre-set priority system. In this mode, the user will experience the inverter drawing power from the solar arrays to power the loads. When/if the solar power is insufficient, the inverter will then switch to bypass mode to power loads from AC input. The inverter will only power loads with battery when there are no other options.
- **Grid Sell Back with AC Couple:** The inverter will operate with full functionality while still allowing the inverter to sell back to the grid using the GEN port for an AC coupled system.

### SELF-CONSUMPTION MODE

Ensure the inverter is in standby mode before making any changes to the system settings.

Listed below are the combination of settings to achieve Self-Consumption Mode via the mobile app or monitoring website for single inverter operations.



#### NOTE

Verify settings match the images below. If any settings are missing from the list below, contact the distributor for more information regarding commissioning.

#### 1. Step 1

Grid Sell Back

#### 2. Step 2

PV Input Mode

#### 3. Step 3

Run Without Grid

#### 4. Step 4

Seamless EPS switching

#### 5. Step 5

Fast Zero Export

## 6. Step 6

On-Grid Cut-Off SOC(%) (?)	25	Set
----------------------------	----	-----

## 7. Step 7

Charge Current Limit(Adc)	100	Set
---------------------------	-----	-----

## 8. Step 8

Discharge Current Limit(Adc) (?)	100	Set
----------------------------------	-----	-----

**BATTERY BACKUP MODE**

Ensure the inverter is in standby mode before making any changes to the system settings.

Listed below are the combination of settings to achieve Battery Backup Mode via the mobile app or monitoring website.

**NOTE**

Verify settings match the images below. If any settings are missing from the list below, contact the distributor for more information regarding commissioning.

## 1. Step 1

Grid Sell Back	Enable	Disable
----------------	--------	---------

## 2. Step 2

PV Input Mode	7: PV1&2&3 in	Set
---------------	---------------	-----

## 3. Step 3

Run Without Grid	Enable	Disable
------------------	--------	---------

## 4. Step 4

Fast Zero Export	Enable	Disable
------------------	--------	---------

## 5. Step 5

Seamless EPS switching	Enable	Disable
------------------------	--------	---------

## 6. Step 6

AC Charge Enable

## 7. Step 7

Charge Current Limit(Adc)

## 8. Step 8

Start AC Charge SOC(%)    
Stop AC Charge SOC(%)

## 9. Step 9

AC Charge Start Time 1  :    
AC Charge End Time 1  :

## 10. Step 10

Battery Priority (?)

## 11. Step 11

On-Grid Cut-Off SOC(%) (?)

## 12. Step 12

Discharge Current Limit(Adc) (?)

## GRID SELL BACK WITH AC COUPLE

Ensure the inverter is in standby mode before making any changes to the system settings. To achieve Grid Sell Back w/ AC Couple working mode, refer to the following settings.



### NOTE

Verify settings match the images below. If any settings are missing from the list below, contact the distributor for more information regarding commissioning.

#### 1. Step 1

Battery Priority (?)

#### 2. Step 2

PV Input Mode 7: PV1&2&3 in

#### 3. Step 3

Run Without Grid

#### 4. Step 4

Seamless EPS switching

#### 5. Step 5

Charge Current Limit(Adc) 100

#### 6. Step 6

AC Couple

#### 7. Step 7

AC Couple Start SOC(%) 25   
AC Couple End SOC(%) 100

#### 8. Step 8

Discharge Current Limit(Adc) (?) 100

#### 9. Step 9

On-Grid Cut-Off SOC(%) (?) 25

## 16. ESS MAINTENANCE

The information in this section provides guidance on routine general maintenance practices intended to support safe operation, maintain system performance, and promote long term reliability of the ESS.

**Table 16.1 – ESS Maintenance**

ACTION	FREQUENCY	DESCRIPTION	RESPONSIBILITY
Visual Inspection	Monthly	<ul style="list-style-type: none"> <li>Check inverter and battery enclosures for damage, corrosion, or overheating.</li> <li>Confirm ventilation is clear, wiring is secure, and labels are legible.</li> <li>Observe for unusual noise, vibration, or odors.</li> </ul>	User
Operational Check	Quarterly	<ul style="list-style-type: none"> <li>Review system status indicators and fault logs.</li> <li>Confirm normal operating temperatures.</li> <li>Confirm all disconnecting means are accessible and functional.</li> </ul>	User
Electrical & Mechanical Inspection	Annually	<ul style="list-style-type: none"> <li>Torque accessible electrical connections per manufacturer specifications.</li> <li>Inspect mounting hardware, grounding, and bonding.</li> <li>Check all power and communication cables for wear or damage.</li> </ul>	Qualified Technician
Environmental & Site Conditions	Annually or post-events	<ul style="list-style-type: none"> <li>Verify installation area is dry, clean, and within environmental limits.</li> <li>Inspect system after severe weather, flooding, seismic activity, or extended outages.</li> </ul>	<ul style="list-style-type: none"> <li><b>User:</b> No damage detected.</li> <li><b>Qualified Technician:</b> Damage detected.</li> </ul>
Firmware & Software Review	As needed	<ul style="list-style-type: none"> <li>Check for firmware or software updates.</li> <li>If needed, apply updates according to the manufacturer's instructions.</li> <li>After the update, confirm configuration settings remain correct.</li> </ul>	<ul style="list-style-type: none"> <li><b>User:</b> If no system downtime is needed.</li> <li><b>Qualified Technician:</b> If update requires system downtime.</li> </ul>

### CAUTION

- Do not lean on, place objects on, or hang items from the ESS, including its associated wiring or conduit.
- To clean the exterior, gently wipe with a soft, lint-free cloth. If needed, dampen the cloth with mild soap and water.
- Avoid chemical cleaners and solvents, and exposure to flammable or corrosive chemicals or vapors.

## 16.1 BATTERY END OF LIFE

The EG4® battery is designed to last more than 15 years with proper use. We have devoted extensive effort to ensure it retains its charge through thousands of cycles. However, when it's time to retire the battery, several factors should be considered.

Lithium iron phosphate (LFP) batteries are classified as hazardous materials and should not be disposed of in regular trash. Many websites and organizations offer free or low-cost recycling services for these batteries. At EG4, we recognize that our customers are located throughout the United States and worldwide. We recommend searching online for "Lithium Battery Disposal Near Me," as there are likely many organizations that can safely dispose of LFP batteries.

**It's recommended to call beforehand to verify that the location is open and accepting materials.**

If users cannot find a safe disposal location, EG4 is available to assist. Before disposing of the battery improperly or dumping it, please reach out to our customer service team for help.

## 16.2 UPDATE DONGLE FIRMWARE USING APP

Before starting a dongle firmware update, verify all three LEDs are on and the dongle is online and has access to the monitoring server (EG4® Monitor Website). Dongle updates require downloading firmware from the server over the internet. If there are any issues connecting to the monitoring server, refer to section 17.5. Then connect the phone to the dongle's wireless network.



### NOTE

Before starting a firmware update:

- Verify the Android app is version 1.3.1 or later.
- Verify all 3 dongle LEDs are ON, the dongle is online, and the mobile device is connected to the dongle's Wi-Fi.

1. Connect the mobile device to the dongle's wireless network.
2. Open the EG4® app and select "DONGLE CONNECT".
3. The current dongle firmware will be displayed on the Update firmware button. Select the "Vx.xx Update Firmware" button to start the upgrade process. The EG4 app will automatically locate the latest firmware version available.
4. Select "Vx.x.x UPDATE FIRMWARE" to load the new firmware to the dongle.
5. The dongle FW should immediately load to the dongle followed by the message shown below. Press "OK" and wait for the dongle to reboot, which should not take more than a couple minutes. Once rebooted, verify the dongle firmware was updated using the dongle connect option in the app, or by using Monitor Center.

## 16.3 NETWORK SECURITY

### ENABLING:

The following steps describe the process of configuring and enabling WPA2 security for the dongle's wireless network:

1. Verify the Wi-Fi LED is solid on. If the LED is not on, see section 17.5.
2. Using a supported device, connect the Wi-Fi network created by the dongle, generally it's named as dongle serial number (i.e., BEXXXXXXXX, BJXXXXXXX, BGXXXXXXX).
3. Open the EG4® mobile app and select "DONGLE CONNECT". Then select "DONGLE CONNECT PARAMS".

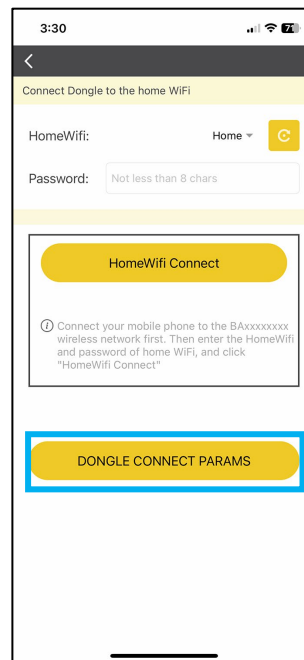
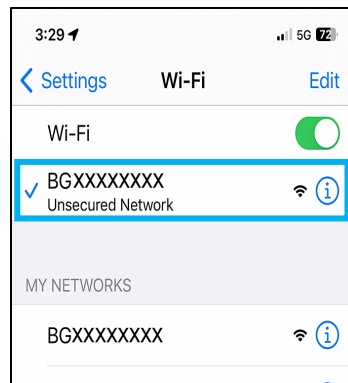
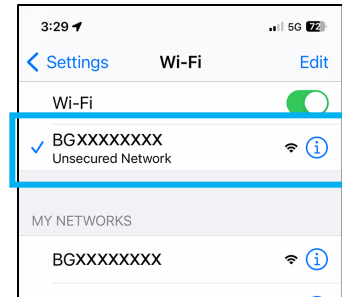

4. Select the Encryption Mode slider to start the configuration process. This step alone will not enable encryption. If the app is closed or the back arrow is pressed to move to the previous screen, this step will need to be completed again.

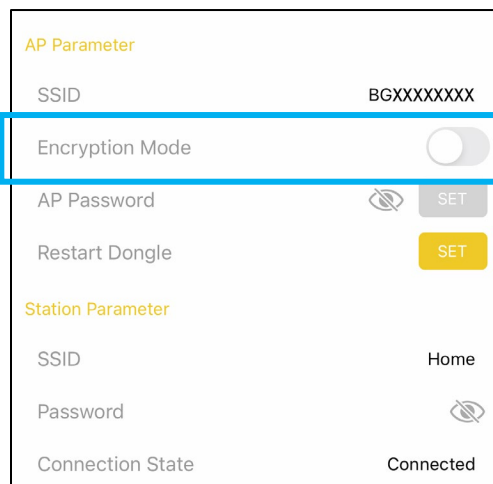

5. Select the “eye” icon and enter the verification code 123123. The “OK” button may need to be selected twice, depending on communication and/or software lag.

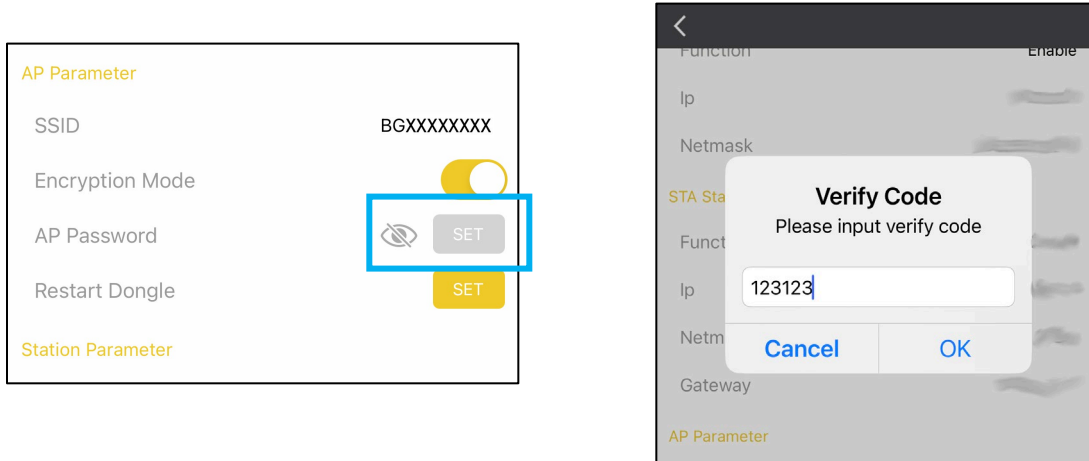

6. The default WPA2 password set at the factory is “12345678”. To change the default password, select inside the password area and overwrite the existing password using the desired password. In the example below, the password is set to “Passw0rd!”.

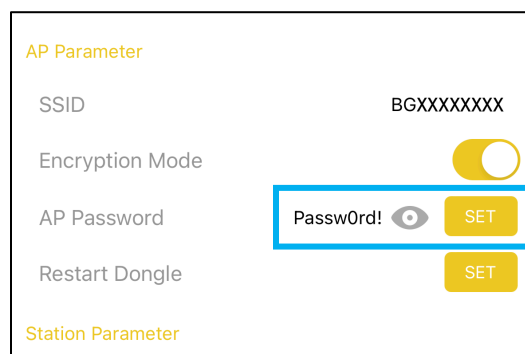

7. Select “SET” to save the password which will also enable WPA2 security. There may be a short pause after selecting the SET button. Press “OK” to verify the setup is complete. The dongle will reboot and should be back online within a couple minutes.

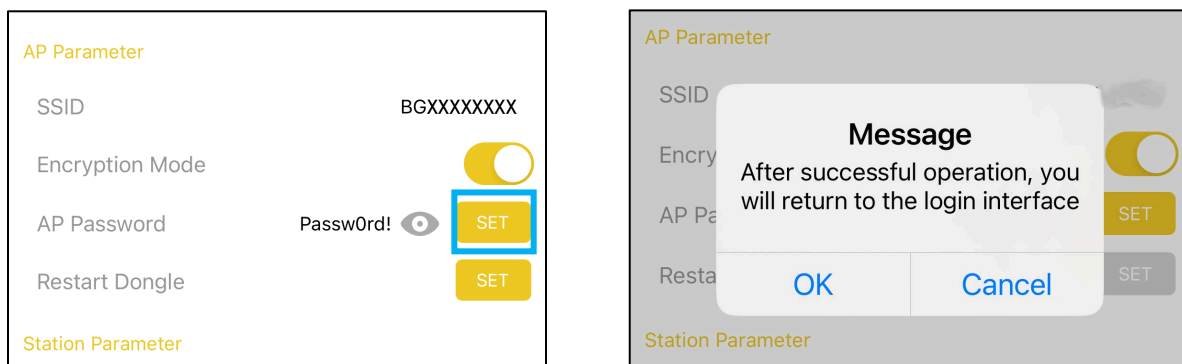

- Go to the phone's Wi-Fi settings and re-select the dongle's Wi-Fi network. The lock icon should appear next to the dongle's wireless network which means security is enabled. Enter the password created in the previous step.

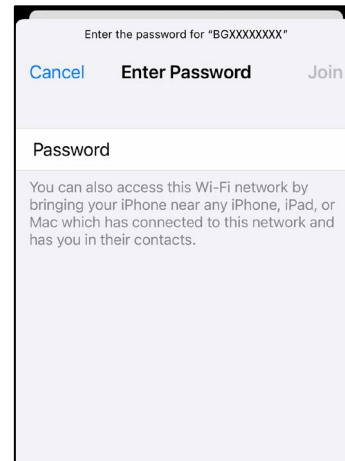
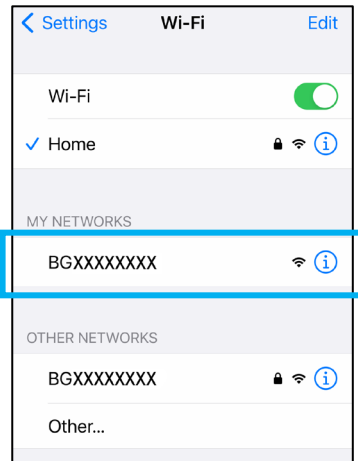

- The EG4® mobile app can now be used as it was previously when security was not enabled. Also note, enabling and setting up WPA2 security on the dongle's Wi-Fi network will not change the dongle's ability to connect to the home Wi-Fi network.

## DISABLING:

There are two options to disable the security settings for the dongle's network.

- Option 1:** Hold down the reset button on the bottom of the dongle for at least 10 seconds and release. This is the quickest and easiest option because it does not require using the currently set WPA2 password set on the dongle's Wi-Fi network.
- Option 2:** Use the EG4 App to disable the security settings on the dongle. This option can only be used if the WPA2 password is known. Follow the step list below:
  - Connect a phone to the dongle's Wi-Fi network. If the network was not previously saved on the current phone, enter the dongle's WPA2 password when prompted.
  - Open the EG4 app and select "DONGLE CONNECT".
  - Under the AP Parameter area, select the slider button next to Encryption Mode to disable security.

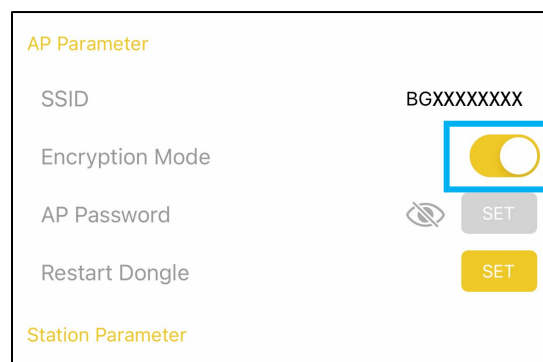

4. Press the “eye” icon and enter the verification code 123123.

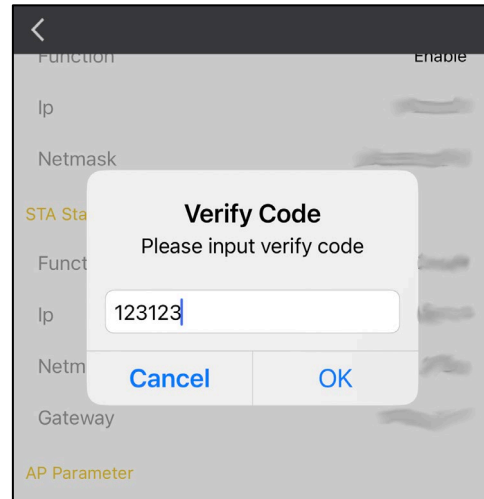
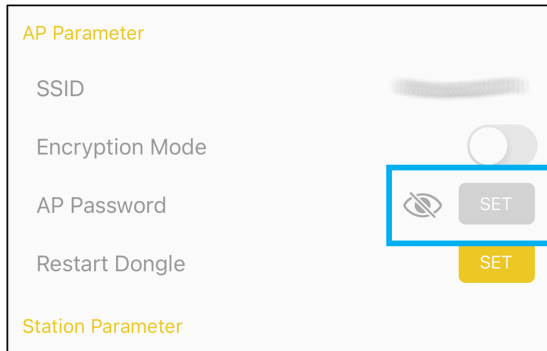

5. Select the “SET” button. There may be a short pause after selecting SET. If this step is not completed, security will NOT be disabled. Press “OK”, when prompted. The dongle will reboot, and security will be disabled after the reboot is complete.

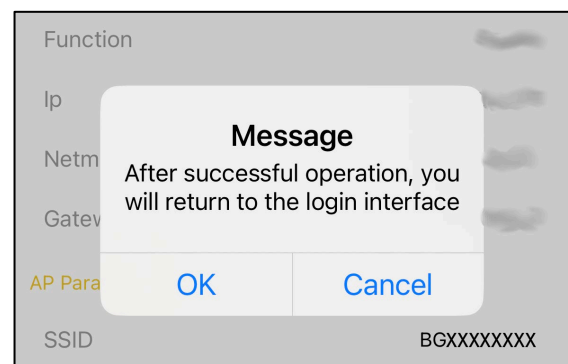
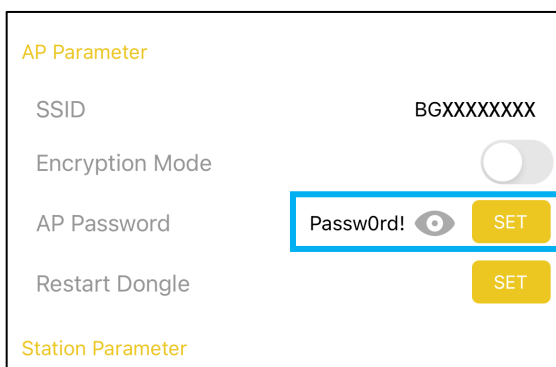

6. When selecting the dongle’s Wi-Fi network, the lock icon should no longer be displayed, and a password should not be required to connect to the dongle’s network.

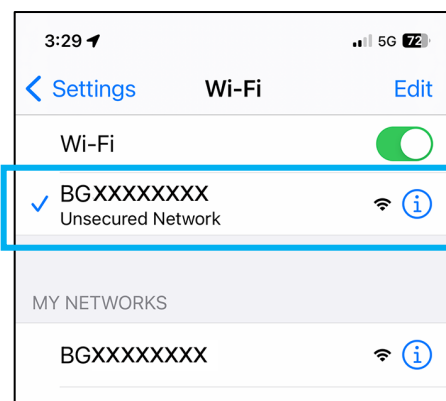

## 17. ESS TROUBLESHOOTING

### REPAIRS





All replacement of parts of the EG4 ESS are to be done by qualified personnel. Only approved materials, components and parts shall be used for replacements.

Unqualified personnel should **NEVER** complete repairs. Repairs should **ONLY** be carried out by qualified personnel. Attempting to repair the product without proper training and authorization may result in product or property damage, personal injury, or the product warranty being voided.

If your product requires repair, please contact the distributor for assistance.

### 17.1 18KPV AND 12KPV STATUS CODES

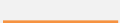
If a warning or fault occurs, users can troubleshoot according to the LED status description and the warning/fault information found in the “Event History” tab on the app or Monitor Center website.

LED	Display	Description	Action
Green LED	Solid lit 	Working normally	No action needed
	Flashing 	Firmware upgrading	Wait until update is complete
Yellow LED	Solid lit 	Warning, inverter may stop working	Needs troubleshooting
Red LED	Solid lit 	Fault, inverter will stop working	Needs troubleshooting

Website

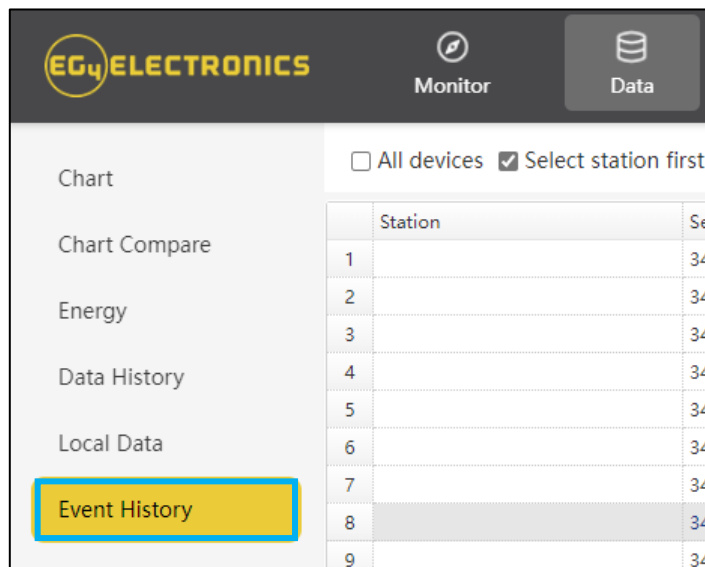

Mobile App



## 17.2 FAULT DEFINITIONS & TROUBLESHOOTING

If the dot on the left of the fault item is red, it means the fault is active.  
When the dot is grey, it means the fault is inactive.

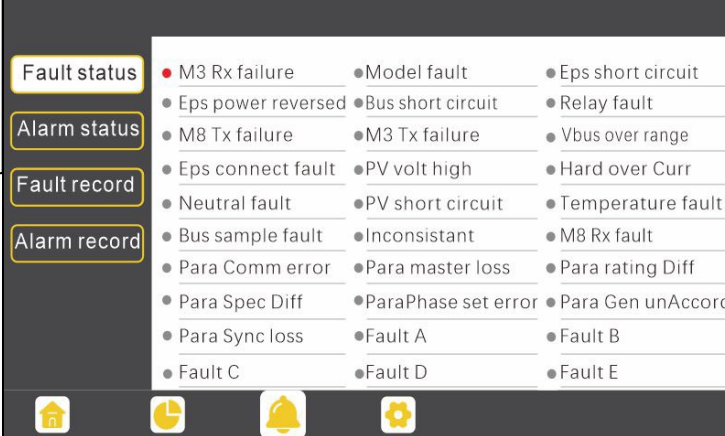

Category	Item	Status
Fault status	M3 Rx failure	Active (Red dot)
	Model fault	Inactive (Grey dot)
	Eps short circuit	Inactive (Grey dot)
	Eps power reversed	Inactive (Grey dot)
Alarm status	Bus short circuit	Inactive (Grey dot)
	Relay fault	Inactive (Grey dot)
	Vbus over range	Inactive (Grey dot)
	M8 Tx failure	Inactive (Grey dot)
Fault record	M3 Tx failure	Inactive (Grey dot)
	Eps connect fault	Inactive (Grey dot)
	PV volt high	Inactive (Grey dot)
	Hard over Curr	Inactive (Grey dot)
Alarm record	Neutral fault	Inactive (Grey dot)
	Temperature fault	Inactive (Grey dot)
	PV short circuit	Inactive (Grey dot)
	Inconsistent	Inactive (Grey dot)
Other	M8 Rx fault	Inactive (Grey dot)
	Para rating Diff	Inactive (Grey dot)
	Para Gen unAccord	Inactive (Grey dot)
	Para Phase set error	Inactive (Grey dot)
Other	Para Comm error	Inactive (Grey dot)
	Para master loss	Inactive (Grey dot)
	Para Spec Diff	Inactive (Grey dot)
	Fault A	Inactive (Grey dot)
	Fault B	Inactive (Grey dot)
Other	Para Sync loss	Inactive (Grey dot)
	Fault C	Inactive (Grey dot)
	Fault D	Inactive (Grey dot)
Other	Fault E	Inactive (Grey dot)
	Fault E	Inactive (Grey dot)

Fault	Meaning	Troubleshooting
M3 Rx failure	M3 microprocessor fails to receive data from DSP	Restart the inverter. If the error persists, contact the supplier.
Model fault	Incorrect model value	
EPS short circuit	Inverter detected short-circuit on load output terminals	<ol style="list-style-type: none"> <li>Check if the L1, L2, and N wires are connected correctly at the inverter load output terminal.</li> <li>Disconnect the load breaker to see if fault remains. If the fault persists, contact the supplier.</li> </ol>
EPS power reversed	Inverter detected power flowing into load terminal	Restart the inverter. If the fault persists, contact the supplier.
Bus short circuit	DC Bus is short circuited	
Relay fault	Relay abnormal	
M8 Tx failure	DSP fails to receive data from M8 microprocessor	
M3 Tx failure	DSP fails to receive data from M3 microprocessor	
Vbus over range	DC Bus voltage too high	Ensure the PV string voltage is within the inverter specification. If string voltage is within range and this fault persists, contact the supplier.
EPS connect fault	Load terminal and grid terminal are connected wired incorrectly or reversed	Check if the wires on load terminal and grid terminal are wired correctly. If the fault persists, contact the supplier.
PV volt high	PV voltage is too high	Check if the PV string voltage is within the inverter specification. If string voltage is within range and this fault persists, contact the supplier.
Hard over curr	Hardware level over current protection triggered	Restart the inverter. If the fault persists, contact the supplier.

Neutral fault	Voltage between N and G is greater than 30V	Ensure the neutral wire is connected correctly.
PV short circuit	Short circuit detected on PV input	Disconnect all PV strings from the inverter. If the error persists, contact the supplier.
Temperature fault	Heat sink temperature too high	Install the inverter in a place with good ventilation and no direct sunlight. If the installation site is okay, check if the NTC connector inside the inverter is loose.
Bus sample fault	Inverter detected DC bus voltage lower than PV input voltage	Restart the inverter, if the fault persists, contact the supplier.
Inconsistent	Sampled grid voltage values of DSP and M8 microprocessor are inconsistent	
M8 Rx fault	M8 microprocessor fails to receive data from DSP	
Para Comm error	Parallel communication abnormal	<ol style="list-style-type: none"> <li>1. Check whether the connection of the parallel cable is loose. Connect the parallel cable correctly.</li> <li>2. Ensure the PIN status of the CAN communication cable from the first to the end inverter is connected correctly.</li> </ol>
Para master loss	No Master in the parallel system	<ol style="list-style-type: none"> <li>1. If a Master has been configured in the system, the fault will automatically be removed after the Master works.</li> <li>2. If a Master has not been configured and there are only Slaves in the system, set the Master first. <b>Note:</b> For a single-unit system, the role of the inverter should be set as "1 phase Master."</li> </ol>
Para rating Diff	Rated power of parallel inverters are inconsistent	Confirm that the rated power of all inverters is the same.
Para Phase set error	Incorrect setting of phase in parallel	First confirm the wiring for the parallel system is correct. Once verified, connect each inverter to the grid. The system will automatically detect the phase sequence and the fault automatically resolves after the phase sequence is detected. If the fault persists, contact the supplier.
Para Gen in Accord	Inconsistent generator connection in parallel	Some inverters are connected to generators, and some are not. Confirm <i>all</i> inverters in parallel are connected to common generator output, or <i>none</i> are connected to generators.
Para sync loss	Parallel inverter fault	Restart the inverter. If the fault persists, contact the supplier.

## 17.3 ALARM DEFINITIONS & TROUBLESHOOTING

If the dot to the left of the fault item is yellow, it means the fault is active. When it is grey, it means the fault is inactive.

The screenshot shows a mobile application interface for alarm status. On the left, there are four buttons: 'Fault status', 'Alarm status', 'Fault record', and 'Alarm record'. The main area displays a list of faults with status indicators (yellow dot for active, grey dot for inactive). The faults listed are:

- Bat Com failure (Active)
- Meter Com failure (Active)
- Lcd Com failure (Inactive)
- Bat reversed (Inactive)
- Trip by Fac abnormal (Inactive)
- Trip by dci high (Inactive)
- Bat volt high (Inactive)
- Offgrid overload (Inactive)
- Offgrid dcv high (Inactive)
- Para Phase loss (Inactive)
- AFCI Com failure (Inactive)
- Bat fault (Inactive)
- Fw mismatch (Inactive)
- Trip by no AC (Inactive)
- Trip by iso low (Inactive)
- PV short circuit (Inactive)
- Bat volt low (Inactive)
- Offgrid overvolt (Inactive)
- RSD Active (Inactive)
- Para no BM set (Inactive)
- AFCI high (Inactive)
- Auto test failure (Inactive)
- Fan stuck (Inactive)
- Trip by Vac abnormal (Inactive)
- Trip by gfci high (Inactive)
- GFCI module fault (Inactive)
- Bat open (Inactive)
- Meter reversed (Inactive)
- Alarm A (Inactive)
- Para multi BM set (Inactive)

Alarm	Meaning	Troubleshooting
Bat com failure	Inverter fails to communicate with battery	Check if the communication cable pinout is correct, and if the correct battery brand on the inverter's LCD is selected. If all is correct but this alarm persists, contact the supplier.
AFCI com failure	Inverter fails to communicate with AFCI module	Restart inverter. If the error continues, contact the supplier.
AFCI high	PV arc fault is detected	Check each PV string for correct open-circuit voltage and short-circuit current. If the PV strings are in good condition, clear the alarm on the inverter LCD.
Meter com failure	Inverter fails to communicate with the meter	Check if the communication cable is connected correctly and in good working condition. Restart inverter. If the alarm persists, contact the supplier.
Bat Fault	Battery cannot charge or discharge	<ol style="list-style-type: none"> <li>1. Check the battery communication cable for correct pinout on both inverter and battery end.</li> <li>2. Check if an incorrect battery brand is selected.</li> <li>3. Check if there is fault on battery's indicator. If there is a fault, contact the battery supplier.</li> </ol>
LCD com failure	LCD fails to communicate with M3 microprocessor	Restart the inverter. If the fault still occurs, contact the supplier.
Fwm mismatch	Firmware version mismatch between the microprocessors	Update the inverter; if the fault persists, contact the supplier.
Fan stuck	Cooling fan(s) are stuck	Check for debris, if the issue persists, contact the supplier.
Trip by GFCI high	Inverter detected leakage current on AC side	<ol style="list-style-type: none"> <li>1. Check if there is ground fault on grid and load side.</li> <li>2. Restart inverter. If the alarm persists, contact the supplier.</li> </ol>
Trip by dci high	Inverter detected high DC injection current on Grid terminal	Restart inverter. If the alarm persists, contact the supplier.

PV short circuit	Inverter detected a short circuit in PV input	<ol style="list-style-type: none"> <li>1. Check whether each PV string is connected correctly.</li> <li>2. Restart inverter. If the alarm persists, contact the supplier.</li> </ol>
GFCI module fault	GFCI module is abnormal	Restart inverter. If the alarm persists, contact the supplier.
Bat volt high	Battery voltage too high	Check whether the battery voltage exceeds 59.9V; battery voltage should be within inverter specification.
Bat volt low	Battery voltage too low	Check whether the battery voltage is under 40V; battery voltage should be within inverter specification.
Bat open	Battery is disconnected from inverter	Check battery breaker or battery fuse. Reconnect as needed.
Off-grid overload	Overload on Load terminal	Check if load power on inverter LOAD terminal is within inverter specification.
Off-grid overvolt	Load voltage is too high	Restart inverter. If the alarm persists, contact the supplier.
Meter reversed	Meter connection is reversed	Check if the meter communication cable is connected correctly on the inverter and meter sides.
Off-grid dcv high	High DC voltage component on load output when running off-grid	Restart inverter. If the alarm persists, contact the supplier.
RSD Active	Rapid shutdown activated	Check if the RSD switch is pressed.
Para phase loss	Phase losing in parallel system	Confirm that the wiring of the inverter is correct. If the Master is set to 3-phase Master, the number of parallel inverters must be $\geq 3$ . (The grid input for each inverter should be connected correctly to Grid L1, L2, L3.) If the Master is set to 2x 208 Master, the number of parallel inverters needs to be $\geq 2$ . (And the grid input of each inverter should be connected correctly to Grid L1, L2, L3.)
Para no BM set	Master is not set in the parallel system	Set one of the inverters in the parallel system as the Master.
Para multi BM set	Multiple Primaries have been set in the parallel system	There are at least two inverters set as the Master in the parallel system. Keep one Master and set the other as Slave.

## 17.4 BATTERY ALARM DESCRIPTION AND TROUBLESHOOTING

When the ALM light on the battery control panel is on, it means that the battery has given an alarm or has been protected from potential damage. Please check the cause of the failure through the app or BMS Tools and take appropriate measures or go directly to the battery site to troubleshoot.

BMS Tools alarms are shown in the table below:

### Warning and protect status definitions:

STATUS	NAME	DEFINITION	ACTION
Warning/ Protect	Pack OV	Pack over-voltage	Module needs to be discharged to lower its voltage.
	Cell OV	Cell over-voltage	Check individual cell voltage in BMS Tools.
	Pack UV	Pack under-voltage	Module needs to be charged.
	Cell UV	Cell under-voltage	Check individual cell voltage in BMS Tools.
	Charge OC	Charge over-current	Incoming current needs to be reduced.
	Discharge OC	Discharge over-current	Discharge current is too high; lower loads.
	Temp Anomaly	Temperature anomaly	Check ambient and module temperature.
	MOS OT	MOSFET over-temperature	BMS temperature is too high. Power off module and cool down location.
	Charge OT	Charge over-temperature	Power off module and cool down location.
	Discharge OT	Discharge over-temperature	Power off module and cool down location.
	Charge UT	Charge under-temperature	Power off module and warm up location.
	Discharge UT	Discharge under temperature	Power off module and warm up location.
Warning	Low Capacity	Low battery capacity	Module needs to be charged.
Warning	Other Error	Error not listed	Contact the distributor
Protect	Float Stopped	Float Stopped	Contact the distributor
Protect	Discharge SC	Discharge short circuit	Discharge current is too high, turn BMS and breaker off and back on to reset. Lower loads



### NOTE

The “Historical Record” tab indicates what occurred with the module before entering a warning or protection state.

## Other common faults and solutions



### NOTE

If any of the warnings or faults from both tables persist, please contact the distributor for additional troubleshooting steps.

Fault	Analysis	Action
Inverter communication failure	Check communication port connection, and battery ID setting.	Input proper "host" battery DIP switch address, and power cycle the battery.
No DC output	Open breaker, or battery voltage is too low.	Check battery breaker or charge the battery.
Power supply unstable	Battery capacity is not at full power.	Check for proper battery cable connection.
Battery cannot be charged fully	DC output voltage is below the minimum charge voltage.	Check the charging settings on the inverter to ensure they match battery requirements.
ALM LED always on	Short circuit	Disconnect the power cable and check all cables.
The battery output voltage is unstable.	Battery management system does not operate normally.	Press the reset button to reset the battery, then reboot the system.
ALM LED flashes 20 times with SOC1 LED on.	Unbalanced voltage within a cell	Deep discharge the battery bank (<20% SOC), then charge battery bank fully.
ALM LED flashes 20 times with SOC2 LED on.	Unbalanced temperature	Contact the distributor.
ALM LED flashes 20 times with SOC 3/4 LED on.	BMS damaged	Contact the distributor.
Different SOC value of batteries in parallel operation.	No issue	Deep discharge the battery bank (<20% SOC), then charge battery bank fully.
Low voltage protection with no LED on	BMS is in low voltage protection, and is in sleep mode	Contact the distributor.
Deeply discharged with "RUN" LED on	The battery voltage is too low to start BMS.	Contact the distributor.

## 17.5 TROUBLESHOOTING DONGLE NETWORK CONNECTION

### ERROR: “SET FAILED” AND/OR “SET PARAMETER FAILED”

- **Description:** This error message may appear after selecting any button in the app that performs an action. For example, selecting the “Home WIFI Connect” button as shown below.
- **Fix:** Confirm the phone is connected to the dongle’s Wi-Fi network and the dongle’s wireless LED is illuminated. If those two conditions are met, wait a few minutes and retry the last step that failed. At times the dongle can become busy or slow to respond to the app.

### ERROR: LOST HOTSPOT CONNECTION

- **Description:** This error will occur when there is an issue connecting to the dongle hotspot properly, or the mobile device has disconnected from the dongle hotspot and is trying to connect using the mobile Cellular Network.
- **Fix:** Verify the phone is not set up to connect to a cellular network when Wi-Fi connectivity is poor or is not providing a connection to the internet. The WLAN/Wi-Fi assist can be disabled or the Cellular can be temporarily disabled during the dongle setup process.

### TO DISABLE WLAN AND WI-FI ASSIST

- **Android – Select Settings**, select Cellular, then scroll down the page (screen). Locate ‘WLAN assistant’ and disable this setting.
- **iOS – Select Settings**, select Cellular, then scroll to the bottom of the page (screen). Locate “Wi-Fi- Assist” and disable this setting.

**18. WARRANTY INFORMATION**

For information regarding warranty registration on EG4® Electronics products, please navigate to <https://eg4electronics.com/warranty/> and select the corresponding product to begin the registration process.

# EG4

ELECTRONICS

support@eg4electronics.com  
(903) 609-1988  
www.eg4electronics.com