

EG4 12000XP SYSTEM WIRING DIAGRAMS

TABLE OF CONTENTS

1. 12000XP - Off-Grid
 - 1a. 12000XP - Off-Grid (with Notes)
2. 12000XP - Partial Home Off-Grid with Grid Breaker Input
 - 2a. 12000XP Partial Home Off-Grid with Grid Breaker Input (with Notes)
3. 12000XPs - Whole Home Off-Grid with Grid Input by Service Entrance Panel (Option 1)
 - 3a. 12000XPs - Whole Home Off-Grid with Grid Input by Service Entrance Panel (Option 1) (with Notes)
4. 12000XPs - Whole Home Off-Grid with Grid Input by Service Entrance Panel (Option 2)
 - 4a. 12000XPs - Whole Home Backup with Grid Input by Service Entrance Panel (Option 2) (with Notes)
5. 12000XPs - Whole Home Off-Grid with Grid Input by Supply-Side Tap
 - 5a. 12000XPs Whole Home Off-Grid with Grid Input by Supply-Side Tap (with Notes)
6. 12000XPs - Whole Home Off-Grid with Grid Input by Feeder Tap
 - 6a. 12000XPs Whole Home Off-Grid with Grid Input by Feeder Tap (with Notes)
7. 12000XPs - Parallel Systems - Partial Off-Grid, No Grid Charge, Pass-thru or Bypass
8. 12000XPs - Parallel Systems - Whole Home Off-Grid with Inverter Bypass, No Grid Charge or Pass-Thru
 - 8a. 12000XPs - Parallel Systems - Whole Home Off-Grid with Inverter Bypass, No Grid Charge or Pass-Thru (with Notes)

Overview of 12000XP System Use Cases (See Corresponding Drawing #)

Off-Grid (No Grid Available) Drawing #1

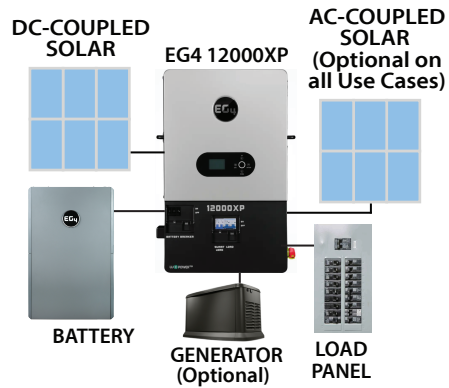

- Remote - No Grid or Seldom Use Grid
- Grid too Expensive
- Add Grid Backup Later
- Energy Autonomy

Partial Home Off-Grid w Grid Charge & Pass-thru Drawing #2

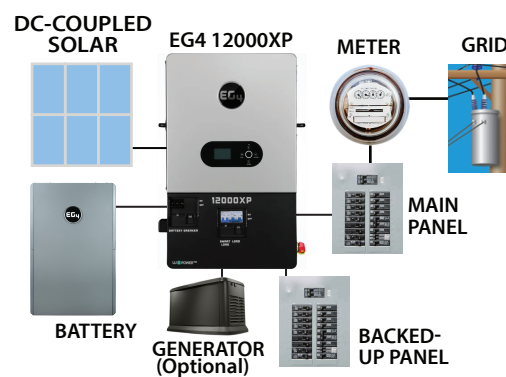

- Reduce Utility Bill
- Reduce Utility Dependence
- Avoid Interconnection Agreement
- Starter System for Expansion to Whole Home Off-Grid

Whole Home Off-Grid w Grid Charge, Pass-thru & Inverter Bypass Drawings #3,4,5,6

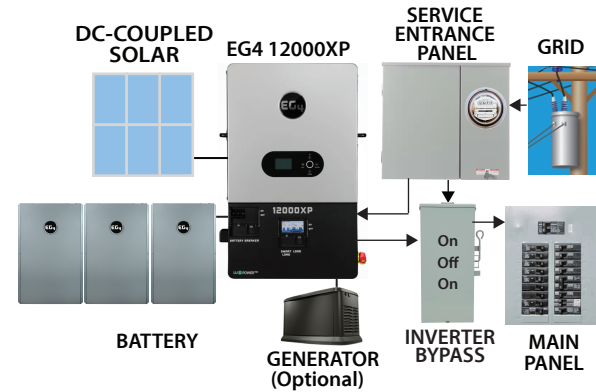

- Reduce Utility Bill
- Reduce or Eliminate Utility Dependence
- Avoid Interconnection Agreement
- Use Grid only during Extensive Cloudy Periods

Parallel Systems Partial Off-Grid No Grid Charge, Pass-thru or Bypass Drawing #7

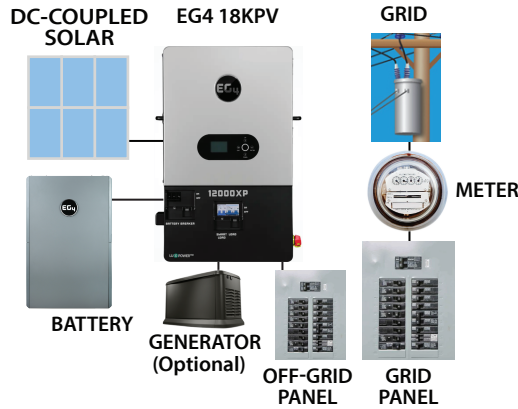

- Reduce Utility Bill
- Reduce or Eliminate Utility Dependence
- Avoid Interconnection Agreement
- Use Grid only for Large Loads

Parallel Systems Whole Home Off-Grid With inverter Bypass No Grid Charge or Pass-thru Drawing #8

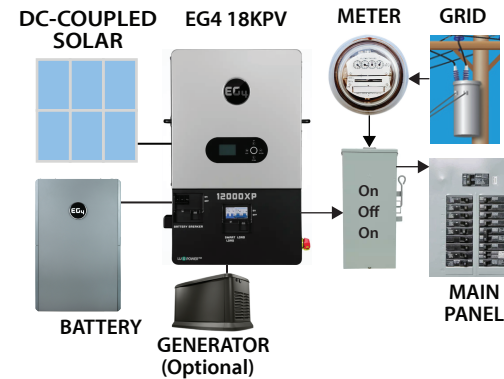

- Reduce Utility Bill
- Reduce or Eliminate Utility Dependence
- Avoid Interconnection Agreement
- Use Grid only as Backup

1. 12000XP - Off-Grid

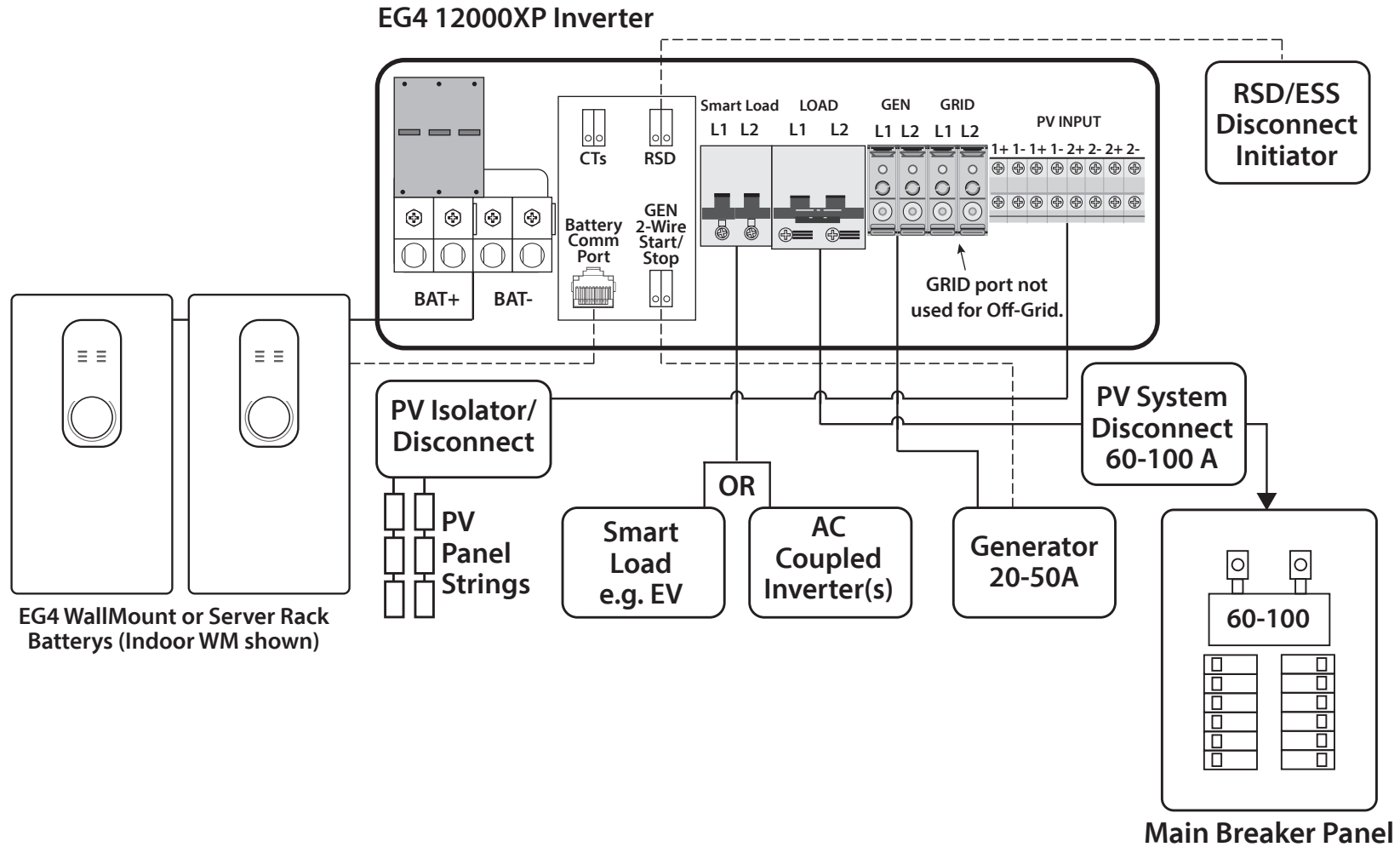

1a. 12000XP - Off-Grid (with Notes)

One Inverter shown. As many as 16 12000XPs can be paralleled for more power. With multiple inverters use combiner panels to combine inputs and outputs as shown in Drawings #4 and #5. Three inverters is roughly equivalent to a 200 Amp utility service since they are 160 Amp continuous rated.

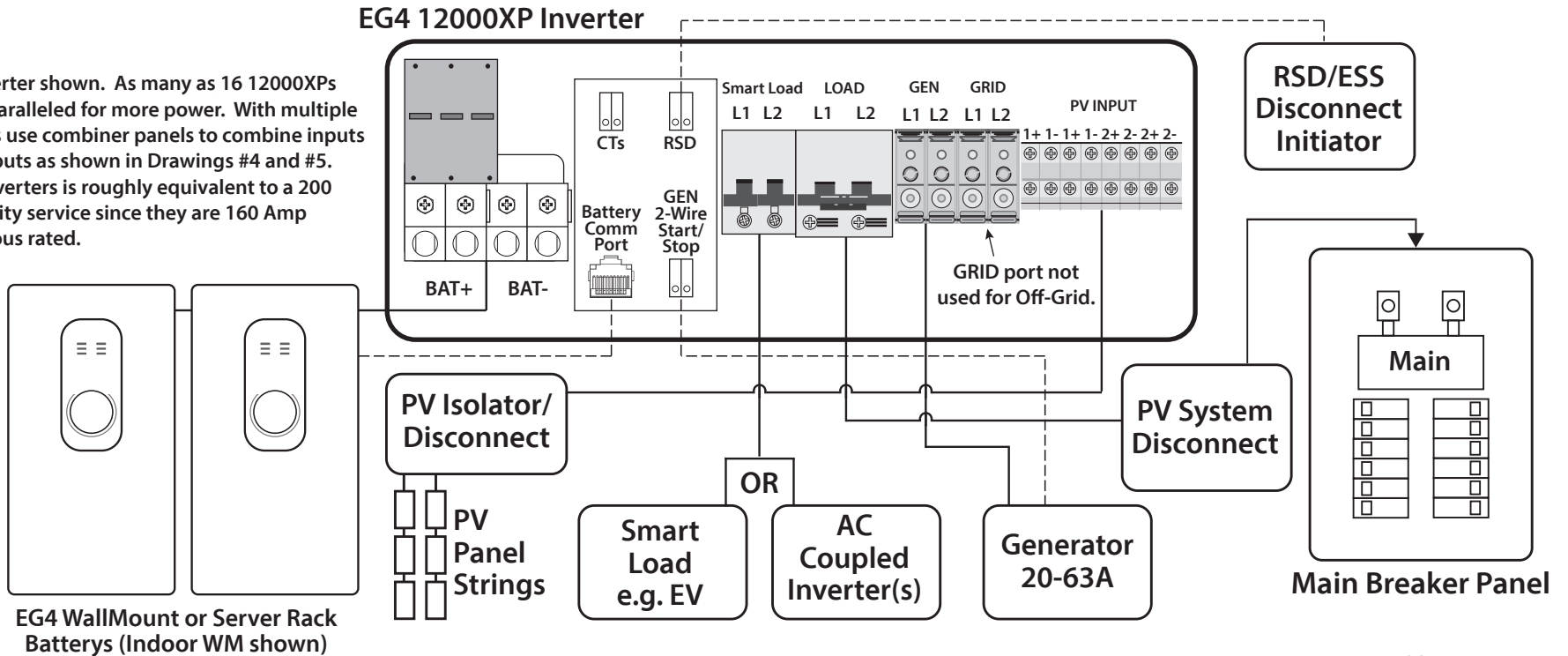

PV INPUT DATA	
Number of MPPTS	2
INPUTS PER MPPT	2/2
MAX. USABLE INPUT CURRENT	35A/35A
MAX. SHORT CIRCUIT INPUT CURRENT	44A/44A
DC INPUT VOLTAGE RANGE	100 - 480 VDC
MIN. STARTUP VOLTAGE	100 VDC
MPPT OPERATING VOLTAGE RANGE	120 - 385 VDC
NOMINAL MPPT VOLTAGE	320 VDC
MAX. UTILIZED SOLAR POWER	24000W (12000 per MPPT)
MAX. RECOMMENDED SOLAR INPUT	28000W (14000 per MPPT)

AC INPUT DATA	
NOMINAL AC VOLTAGE (GRID GENERATOR)	120/240VAC; 120/208vac (L1/L2/N required)
FREQUENCY (GRID GENERATOR)	60 Hz (Default) 50 Hz (Configurable)
GRID MAX. CONTINUOUS AC CURRENT	100A @ 240VAC
MAX. AC INPUT POWER	24000W
GENERATOR MAX. CONTINUOUS CURRENT	62.5A @ 240VAC
RECOMMENDED GENERATOR CAPACITY	6000W - 15000W
AC BYPASS (GRID GENERATOR)	100A 90A

AC OUTPUT DATA	
OUTPUT VOLTAGE	120/240VAC; 208VAC
OUTPUT FREQUENCY	60 Hz (Default) 50 Hz (Configurable)
MAX. CONTINUOUS OUTPUT CURRENT	50A @ 240VAC 57.7A @ 208V
NOMINAL POWER OUTPUT	w/PV: 12000W @ 240V 12000W @ 208V w/out PV: 12000W @ 240V 12000W @ 208V
MAX. CONTINUOUS WATTAGE	12000W (L1-L2) 6000W (L1-N or L2-N)
PEAK PWER (SURGE CAPACITY)	18000W for ~5 seconds 15000W for ~ 10s
POWER FACTOR VALUE	.99
THD (V)	<3%
SWITCHING TIME	<10 ms @ Single / <20ms @ Parallel

The EG4 12000XP inverter is incapable of feeding power back to the utility grid. Therefore it is not an interactive inverter and hence should not need an interconnection agreement with your utility. Likewise NEC code 705.11-13 compliance for interconnected systems does not apply to the Point of Interconnection (POI). It can draw power from the utility grid and hence is essentially a battery charger. See full note on this topic on drawing #2a.

In Off-Grid inverter installations with no grid input or generator present, the output circuit can be sized to 50 Amps x 1.25 = 62.25 A per inverter then choose next breaker size up. Hence switchgear and overcurrent protection for 1 inverter should be sized to at least 70 Amps.

For Off-Grid installations with a Generator or AC Coupled input, up to 90 Amps can be provided per inverter and passed through to the Loads. In these cases, a 90 Amp input and output circuit can be utilized.

DRAWING #12000XP-V1-1L-1a, VERSION 1.2 ©2025 EG4 ELECTRONICS, LLC. ALL RIGHTS RESERVED. THIS DIAGRAM IS FOR ILLUSTRATIVE PURPOSES ONLY. EG4™ IS NOT RESPONSIBLE FOR ACCURACY. FINAL WIRING DIAGRAMS SHOULD BE GENERATED BY A LICENSED PROFESSIONAL AND APPROVED BY ALL AUTHORITIES HAVING JURISDICTION INCLUDING MUNICIPAL, COUNTY, STATE OR ANY OTHER GOVERNMENT OR REGULATORY ENTITY WHICH REGULATES THE USE OF THIS EQUIPMENT WHERE IT MAY BE INSTALLED.

2. 12000XP - Partial Home Backup with Grid Breaker Input

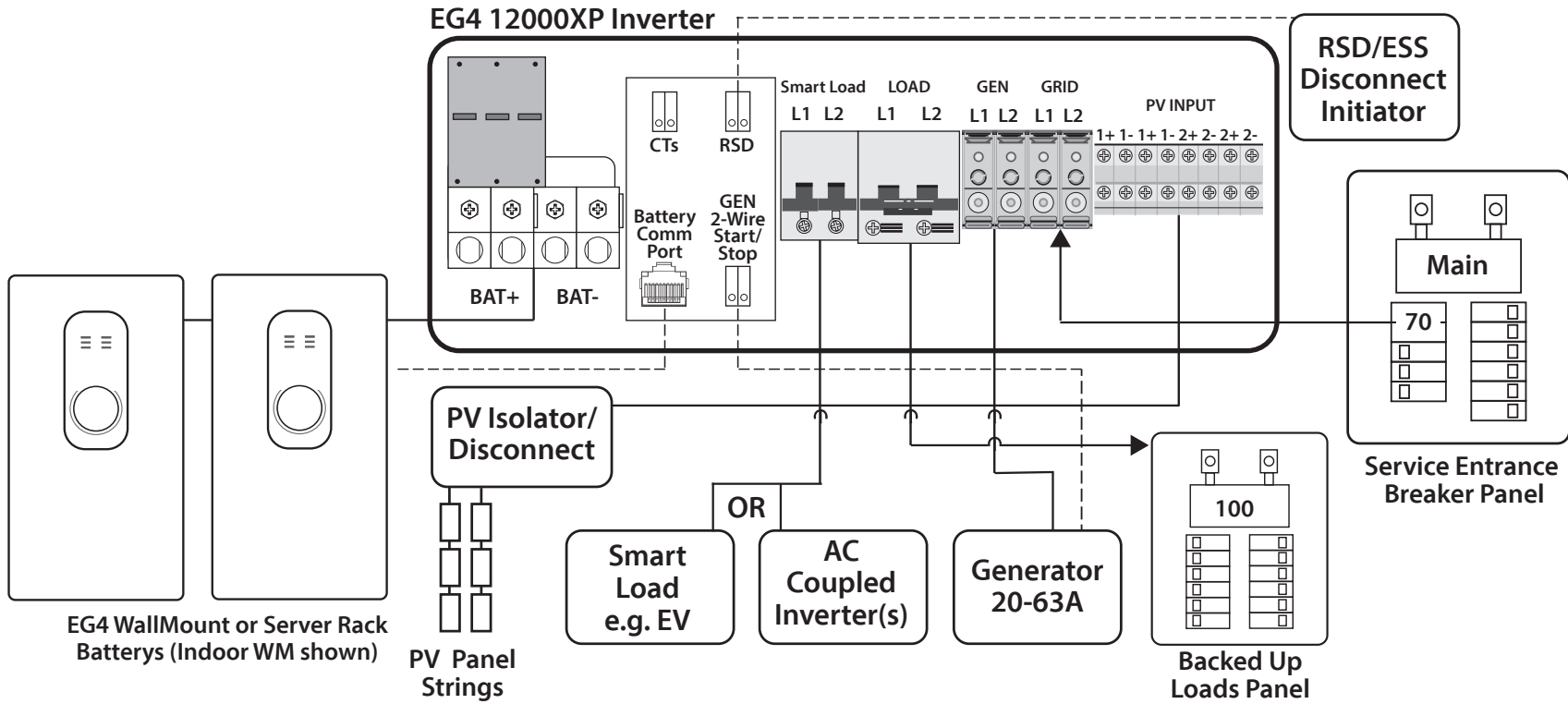

2a. 12000XP - Partial Home Backup with Grid Breaker Input (with Notes)

One Inverter shown. As many as 16 12000XPs can be paralleled for more power. With multiple inverters use combiner panels to combine inputs and outputs as shown in Drawings #4 and #5. Three inverters is roughly equivalent to a 200 Amp utility service since they are 160 Amp continuous rated.

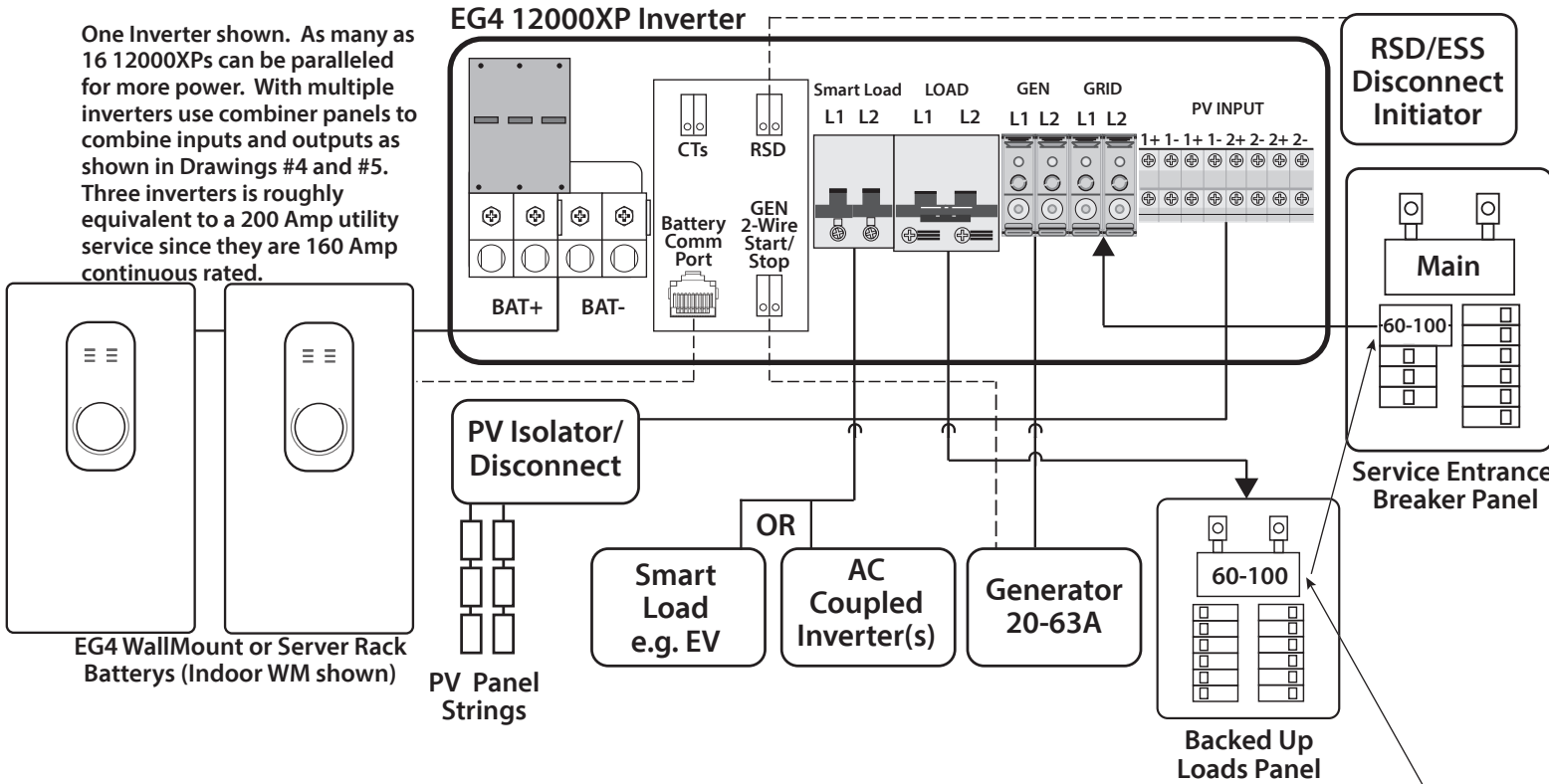

The EG4 12000XP inverter is incapable of feeding power back to the utility grid. Therefore it is not an interactive inverter and hence should not need an interconnection agreement with your utility. It is highly advised to establish this with your utility beforehand that an interconnection agreement is not needed.

Likewise NEC code 705.11-13 compliance for interconnected systems does not apply as there is no bi-directional Point of Interconnection (POI). There is only a feed breaker as any appliance has. It can draw power from the utility grid and hence is essentially a battery charger for code purposes. The 12000XP's UL 9540 listing ensures safe operation as a battery charger.

However many inspectors are accustomed to looking for NEC 705 compliance when they see an inverter connected to a breaker on the main breaker panel. It is highly advised to establish with your inspector beforehand that NEC 705 does not apply.

The size of the AC grid feed breaker and the size of the output subpanel breaker are determined by two factors: 1) How much utility power you want to pass through from the Main Breaker Panel to the Backed up Loads breaker panel. This can be up to the AC pass-through rating of the inverter which is 100 Amps. 2) By how much power you want available to use for battery charging. This can be up to 50 Amps. A 100 Amp breaker on both the grid panel and the backed-up loads subpanel will allow the full 100 Amps to be utilized by the subpanel. If you don't need that much pass-through then you can size the breaker to match the battery charge rate setting you have set in the inverter. To get the maximum battery charging available, use at least a 70 Amp breaker.

PV INPUT DATA	
Number of MPPTS	2
INPUTS PER MPPT	2/2
MAX. USABLE INPUT CURRENT	35A/35A
MAX. SHORT CIRCUIT INPUT CURRENT	44A/44A
DC INPUT VOLTAGE RANGE	100 - 480 VDC
MIN. STARTUP VOLTAGE	100 VDC
MPPT OPERATING VOLTAGE RANGE	120 - 385 VDC
NOMINAL MPPT VOLTAGE	320 VDC
MAX. UTILIZED SOLAR POWER	24000W (12000 per MPPT)
MAX. RECOMMENDED SOLAR INPUT	28000W (14000 per MPPT)

AC INPUT DATA	
NOMINAL AC VOLTAGE (GRID GENERATOR)	120/240VAC; 120/208vac (L1/L2/N required)
FREQUENCY (GRID GENERATOR)	60 Hz (Default) 50 Hz (Configurable)
GRID MAX. CONTINUOUS AC CURRENT	100A @ 240VAC
MAX. AC INPUT POWER	24000W
GENERATOR MAX. CONTINUOUS CURRENT	62.5A @ 240VAC
RECOMMENDED GENERATOR CAPACITY	6000W - 15000W
AC BYPASS (GRID GENERATOR)	100A 90A

AC OUTPUT DATA	
OUTPUT VOLTAGE	120/240VAC; 208VAC
OUTPUT FREQUENCY	60 Hz (Default) 50 Hz (Configurable)
MAX. CONTINUOUS OUTPUT CURRENT	50A @ 240VAC 57.7A @ 208V
NOMINAL POWER OUTPUT	w/PV: 12000W @ 240V 12000W @ 208V w/out PV: 12000W @ 240V 12000W @ 208V
MAX. CONTINUOUS WATTAGE	12000W (L1-L2) 6000W (L1-N or L2-N)
PEAK PWR (SURGE CAPACITY)	18000W for ~5 seconds 15000W for ~10s
POWER FACTOR VALUE	.99
THD (V)	<3%
SWITCHING TIME	<10 ms @ Single / <20ms @ Parallel

BATTERY DATA	
COMPATIBLE TYPES	Lead-Acid (L-A)/Lithium
MAX. CHARGE/DISCHARGE CURRENT (A)	250A
MAX. CHARGE/DISCHARGE POWER (W)	12000W
NOMINAL VOLTAGE	48 VDC
BATTERY VOLTAGE RANGE	46.4 - 60 VDC (Lithium) 38.4 - 60 VDC L-A
RECOMMENDED BATTERY CAPACITY PER INVERTER	>400Ah
HIGH DC CUT-OFF VOLTAGE	59 VDC (Lithium) 60 VDC L-A

3. 12000XPs - Whole Home Backup with Grid Input by Service Entrance Panel (Option 1)

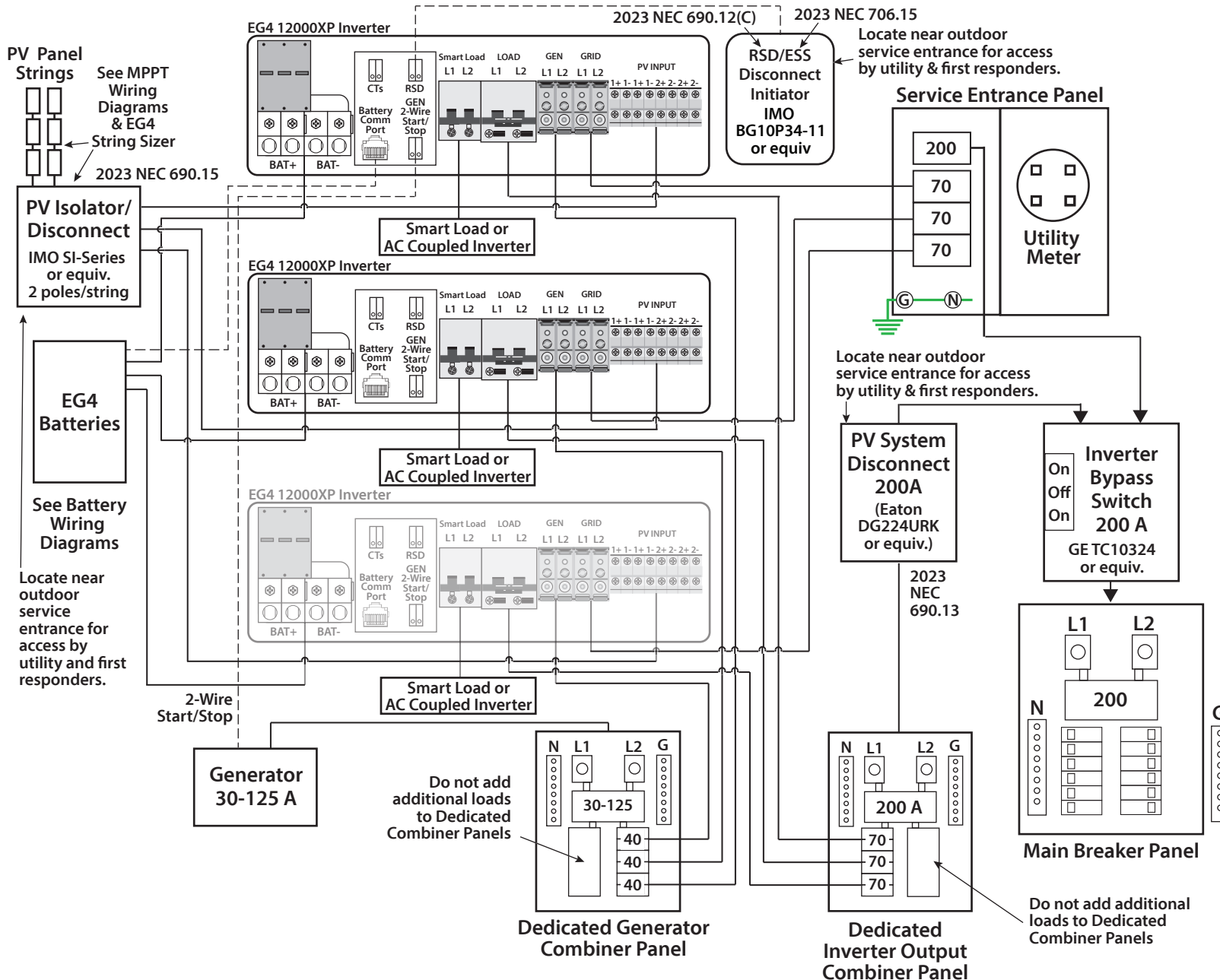

DRAWING #12000XP-V1-1L-3, VERSION 1.4 ©2025 EG4 ELECTRONICS, LLC. ALL RIGHTS RESERVED.
 THIS DIAGRAM IS FOR ILLUSTRATIVE PURPOSES ONLY. EG4™ IS NOT RESPONSIBLE FOR ACCURACY. FINAL WIRING DIAGRAMS SHOULD BE GENERATED BY A LICENSED PROFESSIONAL AND APPROVED BY ALL AUTHORITIES HAVING JURISDICTION INCLUDING MUNICIPAL, COUNTY, STATE OR ANY OTHER GOVERNMENT OR REGULATORY ENTITY WHICH REGULATES THE USE OF THIS EQUIPMENT WHERE IT MAY BE INSTALLED.

3a. 12000XPs - Whole Home Backup with Grid Input by Service Entrance Panel (Option 1) (with Notes)

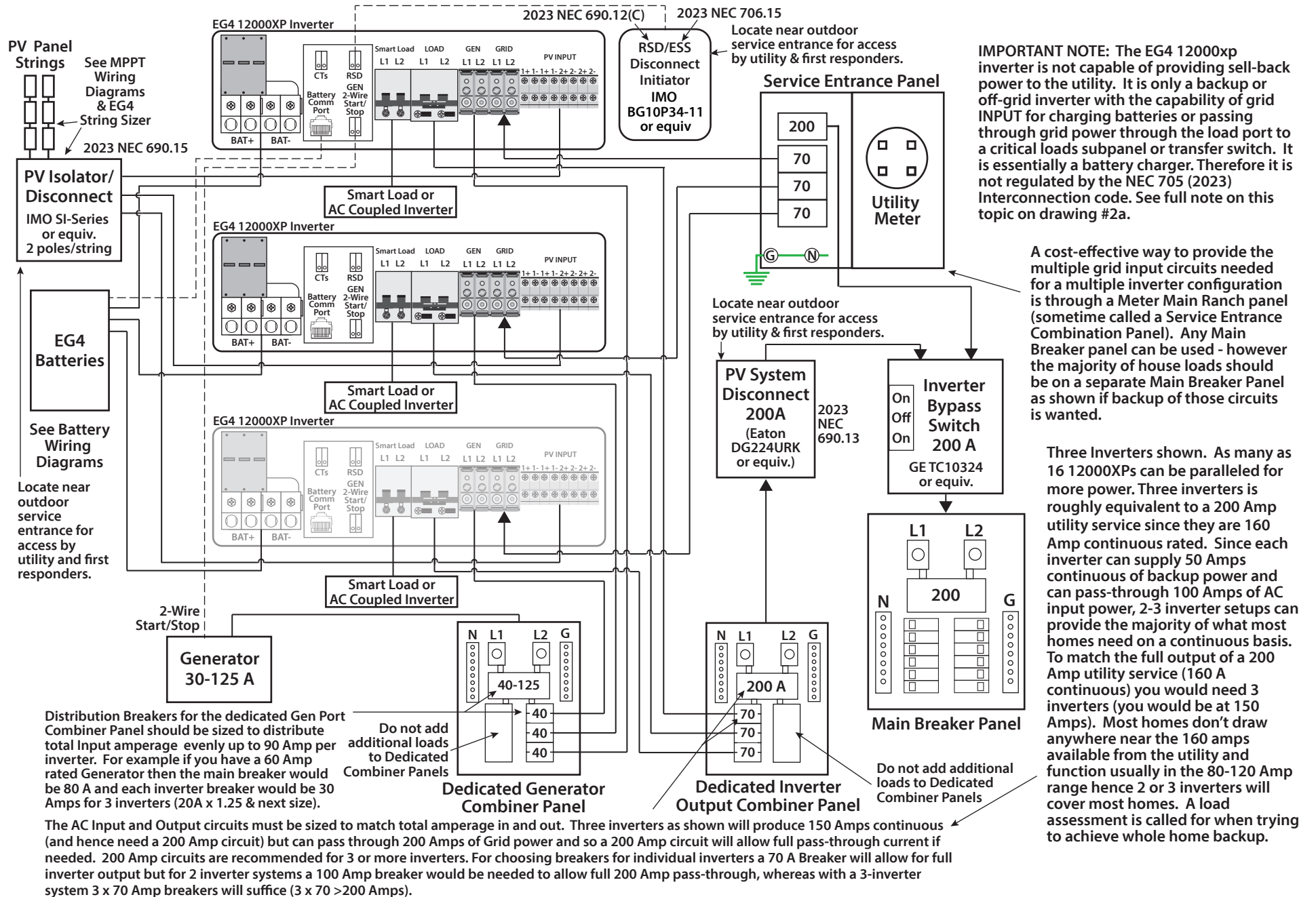

4. 12000XPs - Whole Home Backup with Grid Input by Service Entrance Panel (Option 2)

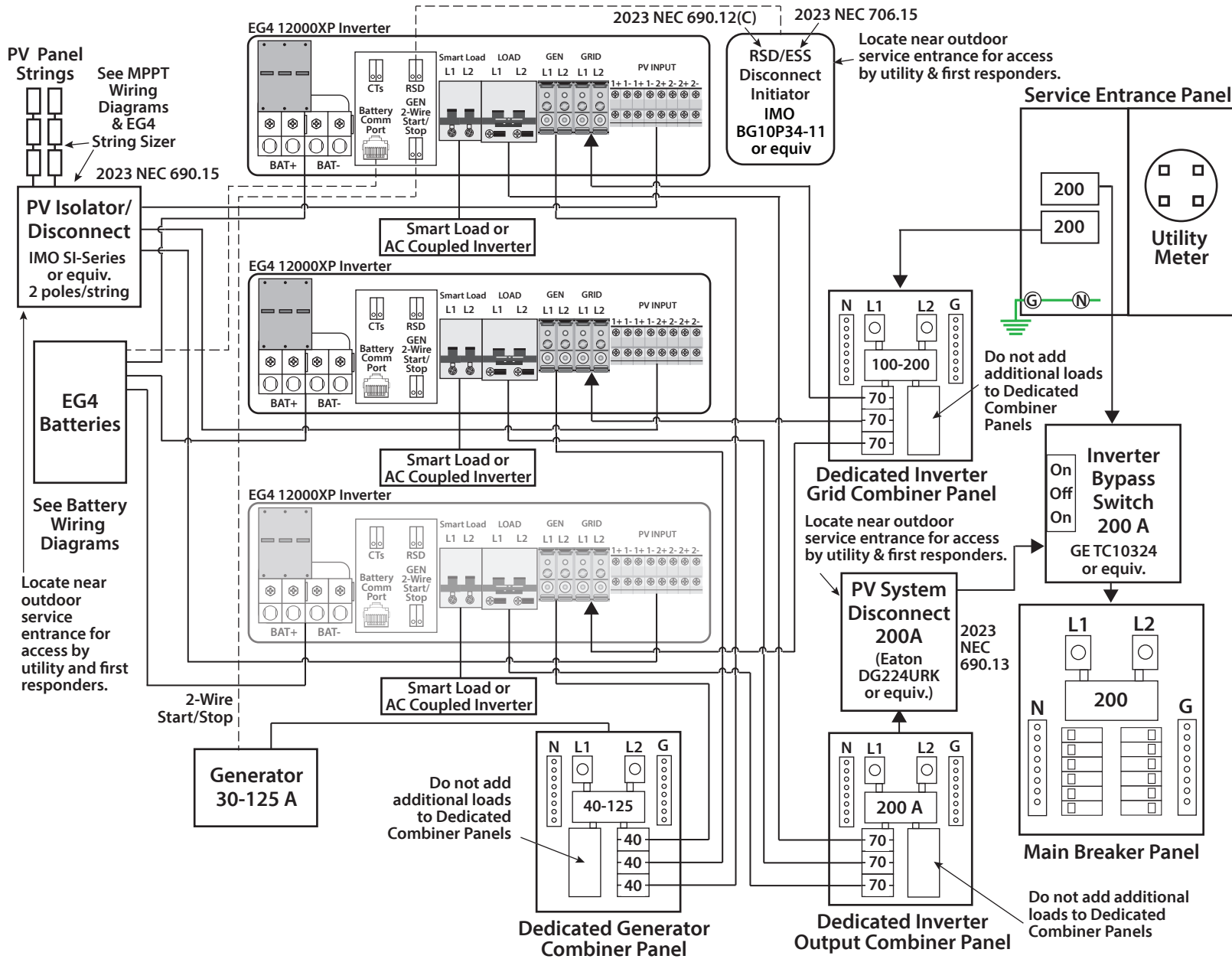

DRAWING #12000XP-V1-1L-4, VERSION 1.4 ©2025 EG4 ELECTRONICS, LLC. ALL RIGHTS RESERVED.
 THIS DIAGRAM IS FOR ILLUSTRATIVE PURPOSES ONLY. EG4™ IS NOT RESPONSIBLE FOR ACCURACY. FINAL WIRING DIAGRAMS SHOULD BE GENERATED BY A LICENSED PROFESSIONAL AND APPROVED BY ALL AUTHORITIES HAVING JURISDICTION INCLUDING MUNICIPAL, COUNTY, STATE OR ANY OTHER GOVERNMENT OR REGULATORY ENTITY WHICH REGULATES THE USE OF THIS EQUIPMENT WHERE IT MAY BE INSTALLED.

4a. 12000XPs - Whole Home Backup with Grid Input by Service Entrance Panel (Option 2) (with Notes)

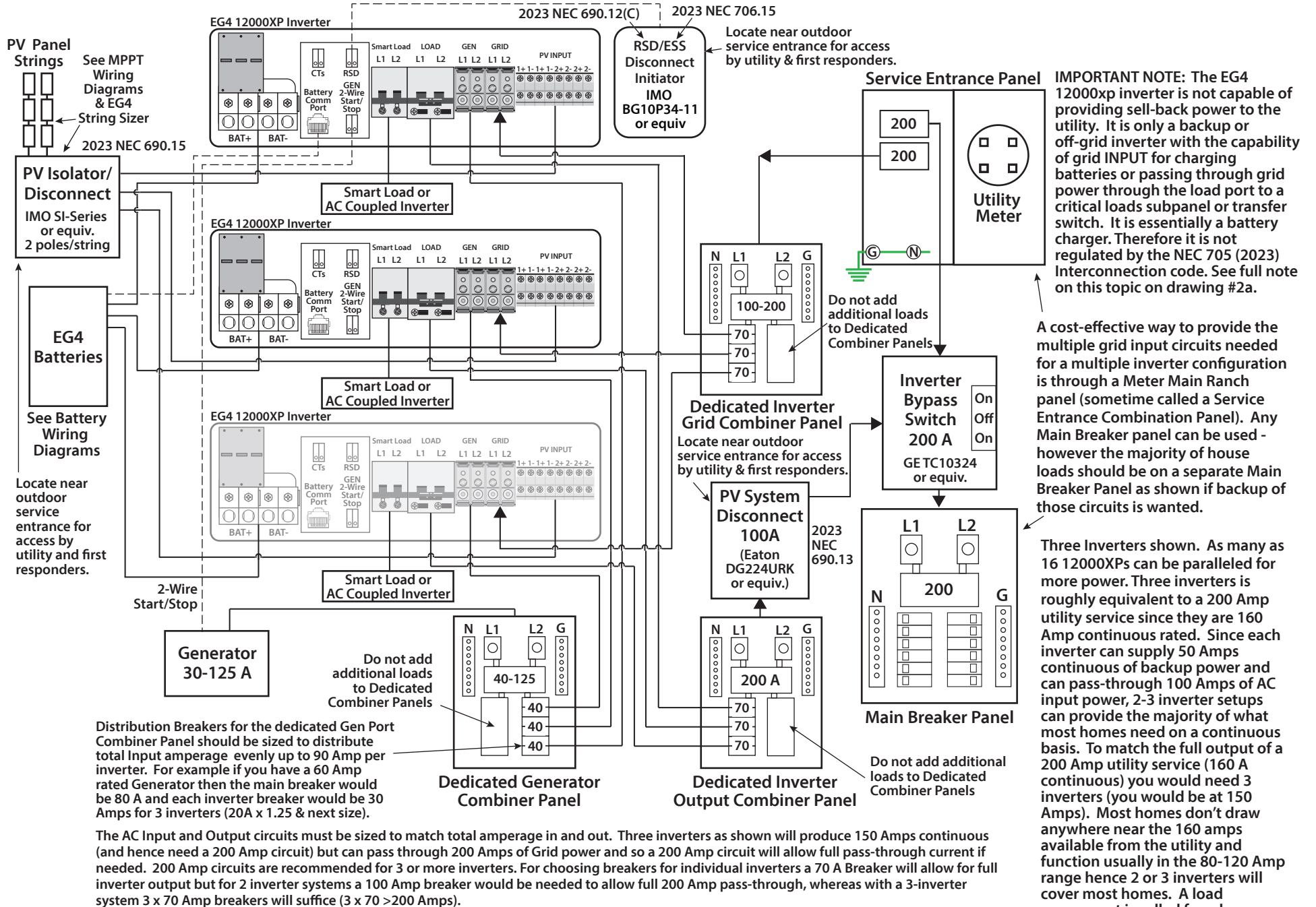

5. 12000XPs - Whole Home Backup with Grid Input by Supply Side Tap

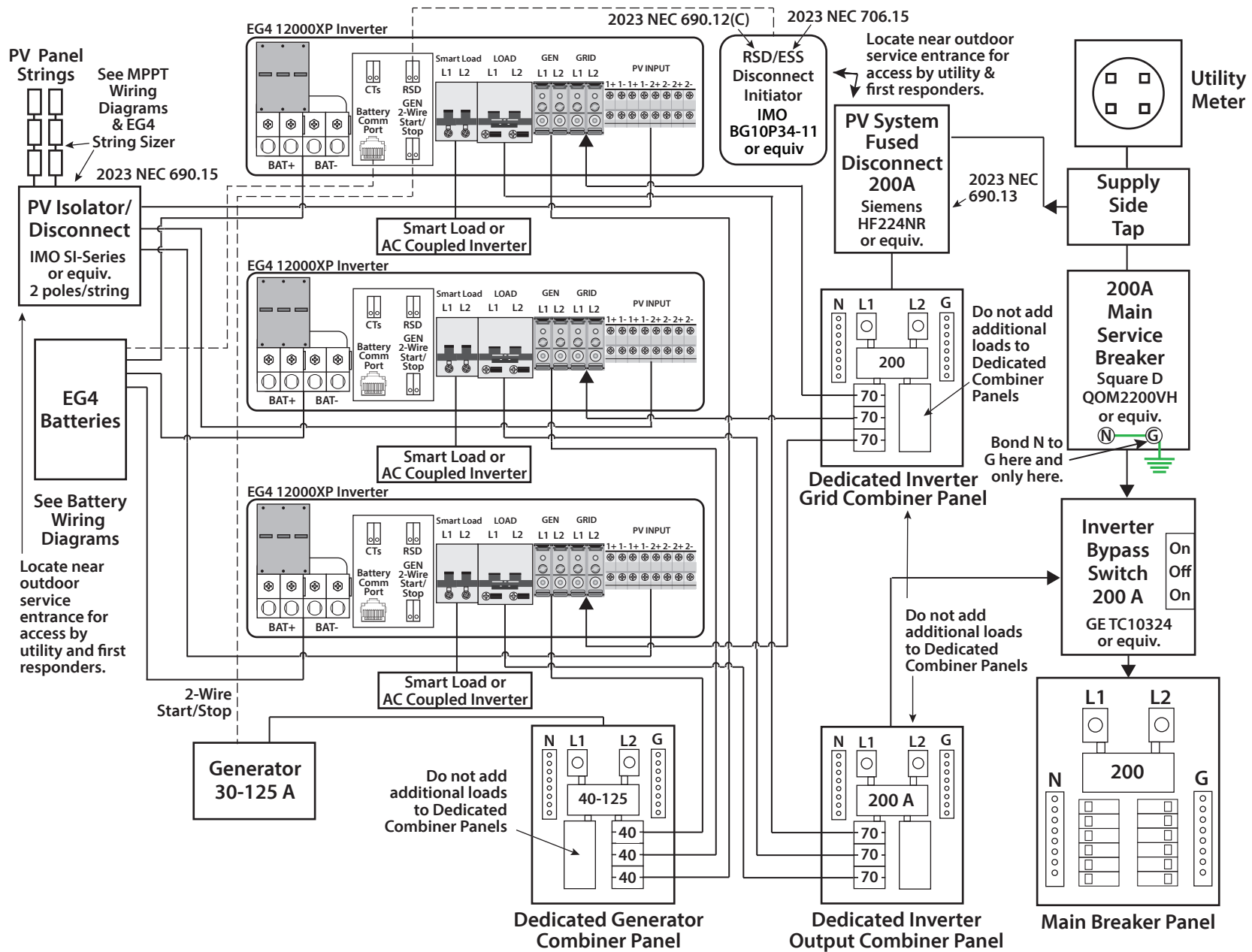

5a. 12000XPs - Whole Home Backup with Grid Input by Supply Side Tap (with Notes)

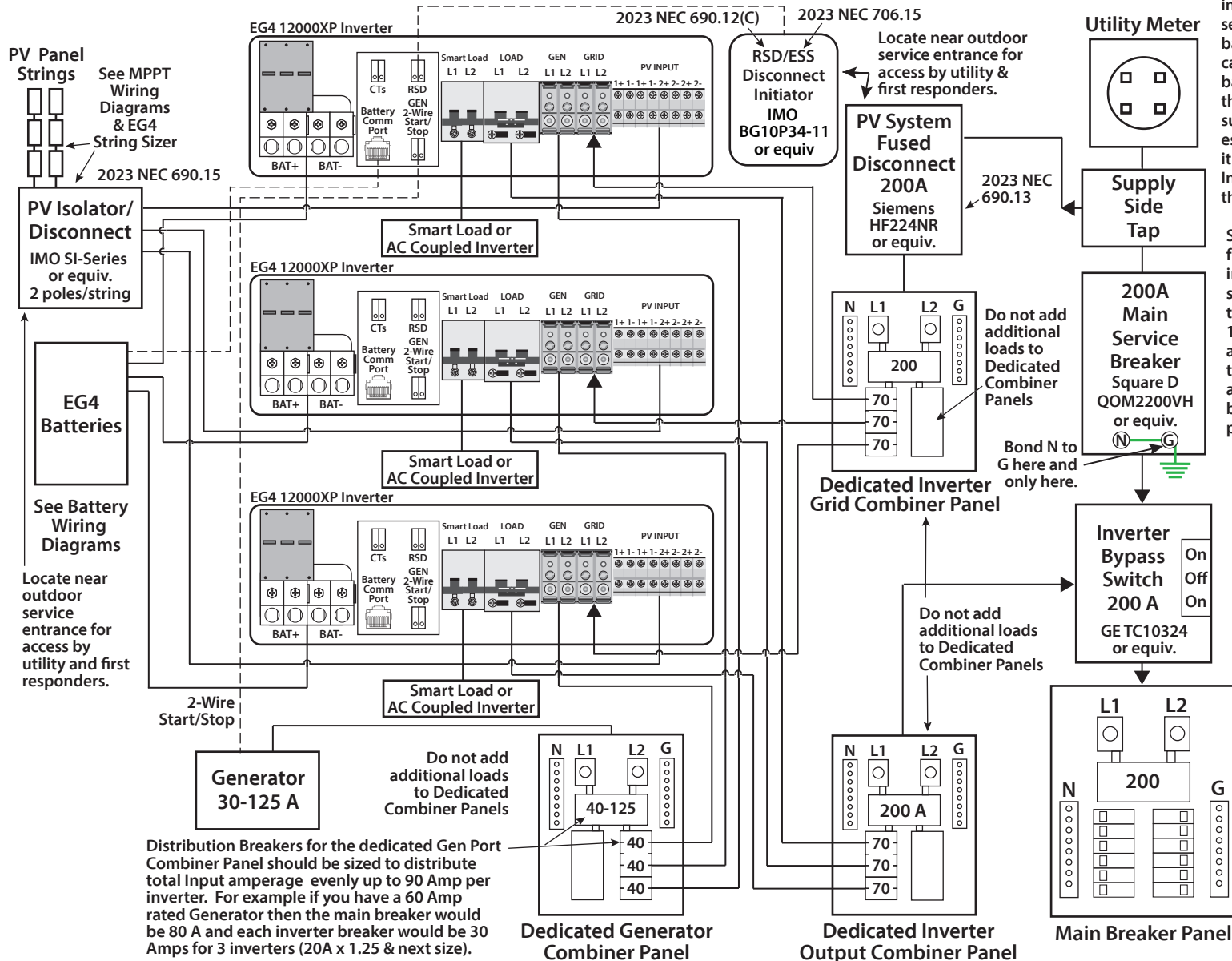

IMPORTANT NOTE: The EG4 12000xp inverter is not capable of providing sell-back power to the utility. It is only a backup or off-grid inverter with the capability of grid INPUT for charging batteries or passing through grid power through the load port to a critical loads subpanel or transfer switch. It is essentially a battery charger. Therefore it is not regulated by the NEC 705 (2023) Interconnection code. See full note on this topic on drawing #2a.

Supply Side Taps allow you to feed the full pass-through capability of the inverter to either your critical loads subpanel or to a transfer switch back to the Main Breaker Panel. Since the 12000 XP has a 50 Amp Off-grid output and an 100 A pass-through rating from the Grid or a Generator you can achieve whole panel or whole home backup by using 2-4 Inverters in parallel.

Caution: A Supply Side Tap will essentially add loads to your Service Entrance since the 12000XP adds close to 50 Amps per inverter to the total house loads with it's battery chargers. With this increased load there is the very real danger of overloading the Service Entrance conductors if the home is already using the full capacity of a 200 A Service. Do this under advisement of your electrician and/or Electrical Inspector. Alternatively use a Feeder Tap to mitigate this issue. Feeder taps locate this extra load on the load side of the Main Breaker - thus protecting all Service Entrance Conductors. (See Feeder Tap Diagram).

Supply Side Taps should be installed by a professional electrician. IlSCO KUP-L-Taps are recommended, but the installer must adhere strictly to installation instructions with proper torque applied (as measured with a torque wrench). Alternatively, a Polaris or Burnby Insulated MultiTap Connector can be used, but these need to be torqued twice - once upon installation and once 24 hours later.

Distribution Breakers for the dedicated Gen Port Combiner Panel should be sized to distribute total Input amperage evenly up to 90 Amp per inverter. For example if you have a 60 Amp rated Generator then the main breaker would be 80 A and each inverter breaker would be 30 Amps for 3 inverters (20A x 1.25 & next size).

The AC Input and Output circuits must be sized to match total amperage in and out. Three inverters as shown will produce 150 Amps continuous (and hence need a 200 Amp circuit) but can pass through 200 Amps of Grid power and so a 200 Amp circuit will allow full pass-through current if needed. 200 Amp circuits are recommended for 3 or more inverters. For choosing breakers for individual inverters a 70 A Breaker will allow for full inverter output but for 2 inverter systems a 100 Amp breaker would be needed to allow full 200 Amp pass-through, whereas with a 3-inverter system 3 x 70 Amp breakers will suffice (3 x 70 > 200 Amps).

DRAWING #12000XP-V1-1L-5a, VERSION 1.4 ©2025 EG4 ELECTRONICS, L.L.C. ALL RIGHTS RESERVED.
 THIS DIAGRAM IS FOR ILLUSTRATIVE PURPOSES ONLY. EG4™ IS NOT RESPONSIBLE FOR ACCURACY. FINAL WIRING DIAGRAMS SHOULD BE GENERATED BY A LICENSED PROFESSIONAL AND APPROVED BY ALL AUTHORITIES HAVING JURISDICTION INCLUDING MUNICIPAL, COUNTY, STATE OR ANY OTHER GOVERNMENT OR REGULATORY ENTITY WHICH REGULATES THE USE OF THIS EQUIPMENT WHERE IT MAY BE INSTALLED.

6. 12000XPs - Whole Home Backup with Grid Input by Feeder Tap

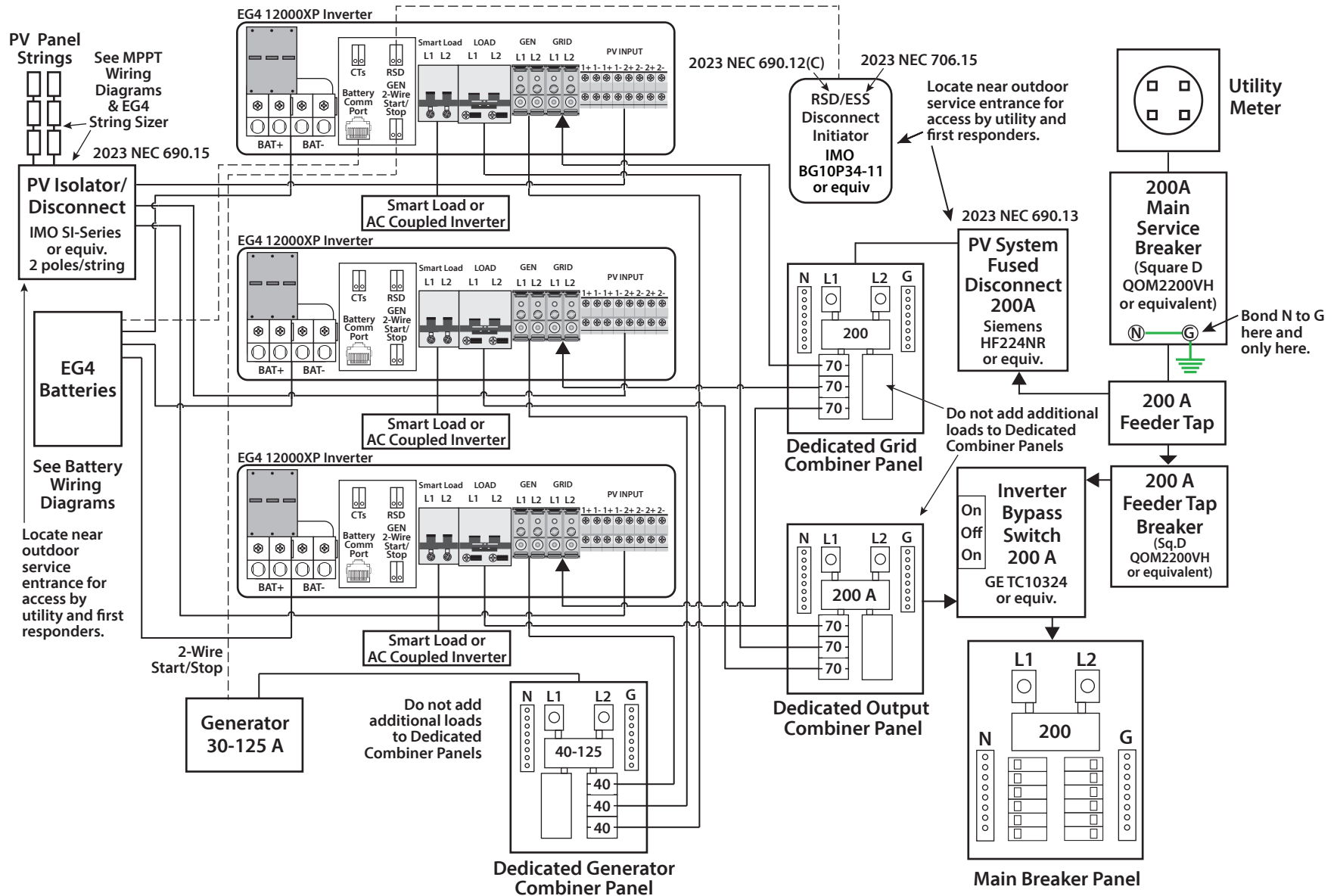

6a. 12000XPs - Whole Home Backup with Grid Input by Feeder Tap (with Notes)

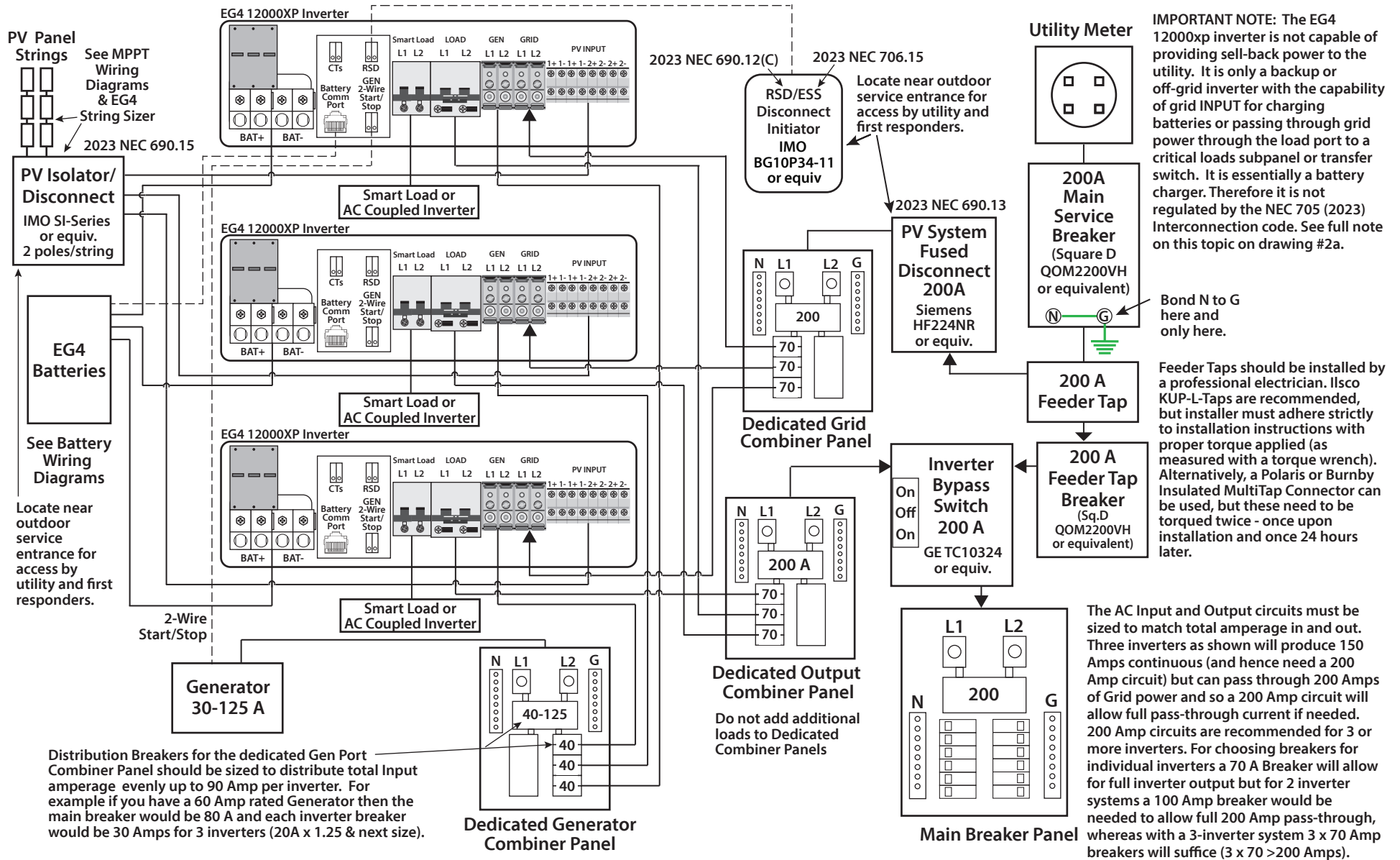

DRAWING #12000XP-V1-1L-6a, VERSION 1.4 ©2025 EG4 ELECTRONICS, LLC. ALL RIGHTS RESERVED. THIS DIAGRAM IS FOR ILLUSTRATIVE PURPOSES ONLY. EG4™ IS NOT RESPONSIBLE FOR ACCURACY. FINAL WIRING DIAGRAMS SHOULD BE GENERATED BY A LICENSED PROFESSIONAL AND APPROVED BY ALL AUTHORITIES HAVING JURISDICTION INCLUDING MUNICIPAL, COUNTY, STATE OR ANY OTHER GOVERNMENT OR REGULATORY ENTITY WHICH REGULATES THE USE OF THIS EQUIPMENT WHERE IT MAY BE INSTALLED.

7. 12000XP - Parallel Systems - No Grid Charge, Pass-Thru or Bypass

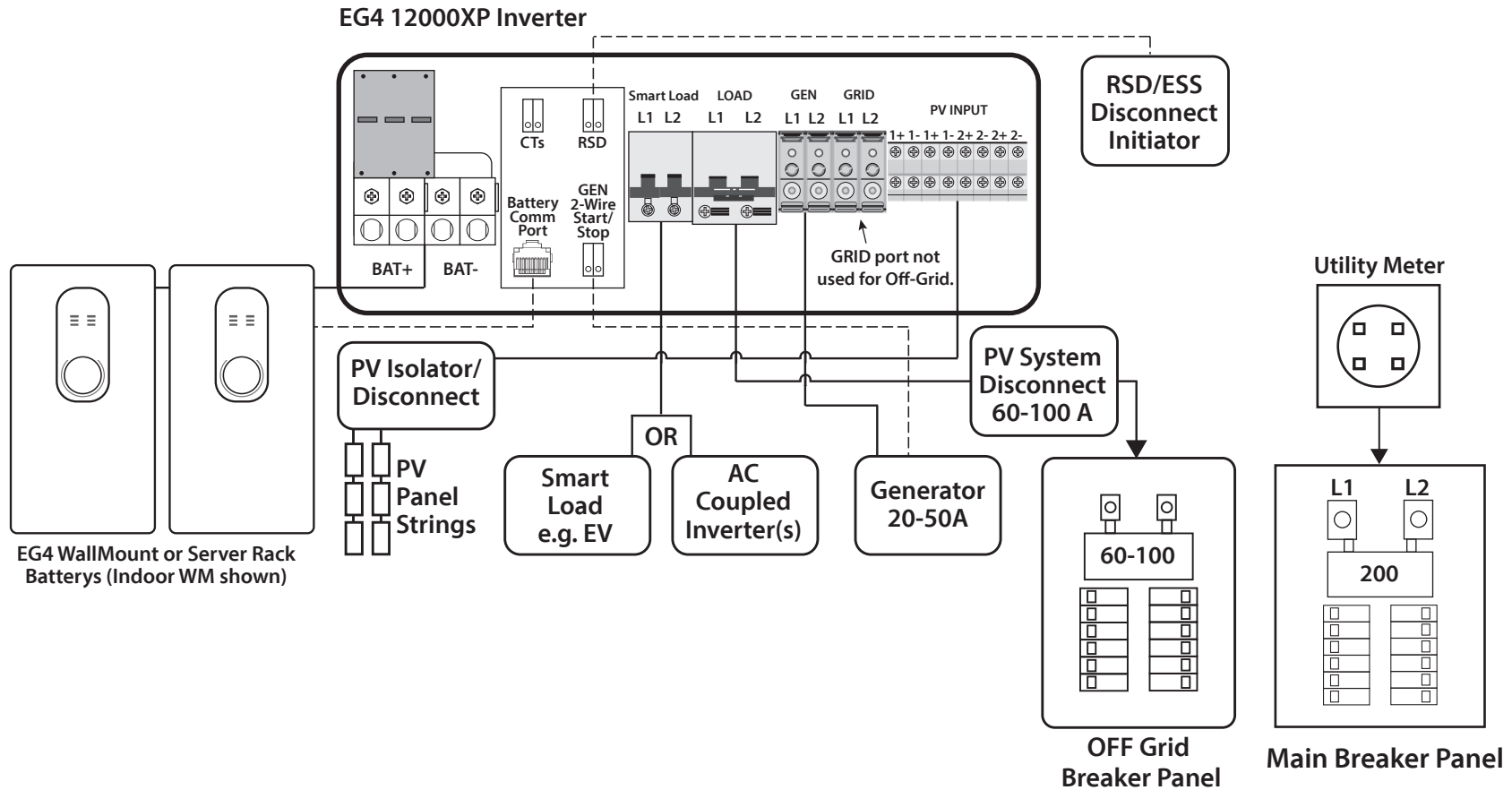

8a. 12000XPs - Parallel Systems - Whole Home Off-Grid with Inverter Bypass, No Grid Charge or Pass-Thru (with Notes)

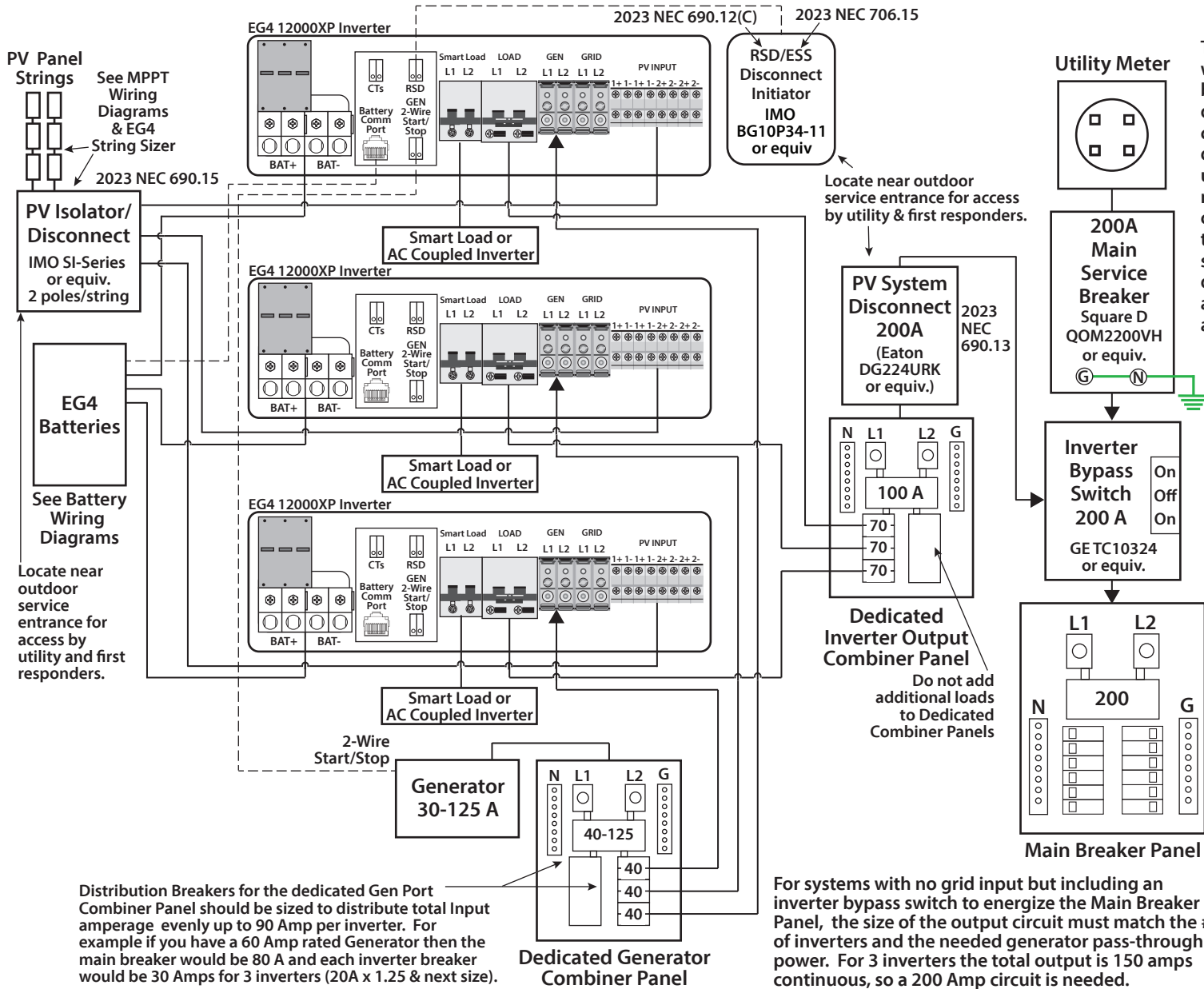

This system as shown will backup a whole home from solar powered backup inverters and batteries but does not allow the batteries to be charged from the grid. However if you do not want to prove to either the utility or the inspector that you have no grid sell-back interconnection this configuration avoids all connection to the utility grid. The manual transfer switch isolates all wiring and literally disconnects the entire solar system and the home from the grid achieving a fully Off-grid configuration.

Three Inverters shown. As many as 16 12000XPs can be paralleled for more power. Three inverters is roughly equivalent to a 200 Amp utility service since they are 160 Amp continuous rated. Since each inverter can supply 50 Amps continuous of backup power and can pass-through 100 Amps of AC input power, 2-3 inverter setups can provide the majority of what most homes need on a continuous basis. To match the full output of a 200 Amp utility service (160 A continuous) you would need 3 inverters (you would be at 150 Amps). Most homes don't draw anywhere near the 160 amps available from the utility and function usually in the 80-120 Amp range hence 2 or 3 inverters will cover most homes. A load assessment is called for when trying to achieve whole home backup.

Locate near outdoor service entrance for access by utility and first responders.

See MPPT Wiring Diagrams & EG4 String Sizer

See Battery Wiring Diagrams

Distribution Breakers for the dedicated Gen Port Combiner Panel should be sized to distribute total Input amperage evenly up to 90 Amp per inverter. For example if you have a 60 Amp rated Generator then the main breaker would be 80 A and each inverter breaker would be 30 Amps for 3 inverters (20A x 1.25 & next size).

Locate near outdoor service entrance for access by utility & first responders.

Do not add additional loads to Dedicated Combiner Panels

For systems with no grid input but including an inverter bypass switch to energize the Main Breaker Panel, the size of the output circuit must match the # of inverters and the needed generator pass-through power. For 3 inverters the total output is 150 amps continuous, so a 200 Amp circuit is needed.