

EG4[®] WALLMOUNT 314Ah INDOOR BATTERY

QUICK START GUIDE



TABLE OF CONTENTS

1.	TECHNICAL SPECIFICATIONS.....	1
2.	ABBREVIATIONS.....	3
3.	BATTERY SAFETY.....	4
3.1	SAFETY INSTRUCTIONS.....	4
3.2	IMPORTANT SAFETY NOTIFICATIONS.....	4
4.	SÉCURITÉ DE LA BATTERIE.....	8
4.1	CONSIGNES DE SÉCURITÉ.....	8
4.2	NOTIFICATIONS DE SÉCURITÉ IMPORTANTES.....	8
5.	PRODUCT OVERVIEW.....	14
5.1	BATTERY DIMENSIONS.....	15
5.2	PACKING LIST.....	16
5.3	BMS OVERVIEW.....	16
5.4	STORAGE INFORMATION.....	17
5.5	BATTERY PERFORMANCE CURVES.....	18
5.6	BATTERY CHARGING.....	19
5.7	FRONT PANEL INDICATOR LIGHTS.....	19
6.	GENERAL INSTALLATION.....	20
6.1	RECOMMENDED TOOLS.....	20
6.2	LOCATION REQUIREMENTS.....	21
6.3	BATTERY INSTALLATION.....	22
6.4	BATTERY WITH CONDUIT BOX.....	26
6.5	BATTERY, CONDUIT BOX, & 18KPV.....	28
6.6	BATTERY, CONDUIT BOX, & 12KPV/FLEXBOSS18/21.....	30
7.	CONNECTING MULTIPLE BATTERIES IN PARALLEL.....	32
7.1	BMS COMMUNICATION WIRING.....	32
7.2	BATTERY CABLE CONNECTIONS.....	34
8.	BATTERY COMMUNICATIONS.....	39
8.1	AUTO-ID BMS PROTOCOL FEATURE.....	39
8.2	BMS AUTO-ID PROCEDURE.....	40
8.3	COMMUNICATION CABLE PINOUT.....	40
9.	BATTERY STARTUP AND SHUTDOWN PROCEDURE.....	41
9.1	STARTUP.....	41
9.2	SHUTDOWN.....	41
10.	TROUBLESHOOTING, MAINTENANCE & DISPOSAL.....	42
10.1	LED INDICATOR STATUS AND DEFINITION.....	42
10.2	MAINTENANCE.....	44
10.3	BATTERY END OF LIFE.....	45
11.	WARRANTY INFORMATION.....	45
12.	CHANGELOG.....	46

1. TECHNICAL SPECIFICATIONS

TYPE & MODEL #		
PARAMETER	SPECIFICATION	
PRODUCT TYPE	LFP Battery	
BATTERY TYPE	Lithium Iron Phosphate (LFP)	
MODEL NUMBER	WM-48-314-IN-XX / WM48314INXX (XX is a number between 00 – 99)	
ELECTRICAL CHARACTERISTICS		
NOMINAL ENERGY CAPACITY	16kWh	
USABLE ENERGY (DOO%)	12.86kWh (80% recommended)	
RECOMMENDED VOLTAGE RANGE	47.5 – 57.6 VDC	
NOMINAL VOLTAGE	51.2 VDC	
CAPACITY	314Ah	
CHARGING VOLTAGE RANGE	56 – 57 VDC	
DISCHARGING CUT-OFF VOLTAGE	47.5 VDC	
MAX CONTINUOUS/RECOMMENDED CHARGE CURRENT	157A/157A	
MAX CONTINUOUS/RECOMMENDED DISCHARGE CURRENT	200A/157A	
CONTINUOUS CHARGE/DISCHARGE POWER	8/10.2 kW	
RECOMMENDED CHARGING/DISCHARGING RATE	0.5C	
SHORT CIRCUIT CURRENT	1700A, 15ms delay	
PEAK POWER	12.8kW (3 sec)	
ROUND-TRIP EFFICIENCY	95%	
MAX PARALLEL UNITS	32	
PROTECTION FEATURES	Over/Under Voltage, Over-Current, Short Circuit, High/Low Temp	
BATTERY MANAGEMENT SYSTEM [BMS]	Integrated, Active Balancing	
COMMUNICATION PROTOCOLS	RS485, CAN	
BATTERY BREAKER	250A	
BATTERY HEATER SPECIFICATIONS		
PARAMETER	SPEC	CONDITION
VOLTAGE	56V	-
POWER CONSUMPTION	448W	-
INTERNAL BATTERY TEMPERATURE	≤32°F (0°C)/≥37°F (3°C)	Heat On/Heat Off
ENVIRONMENTAL SPECIFICATIONS		
STORAGE TEMPERATURE RANGE*	-4 – 131°F (-20 – 55°C)	
HUMIDITY RANGE	5% – 95% RH (non-condensing)	
ALTITUDE	9843 ft. (<3000 m)	
COOLING METHOD	Natural Convection	
DIMENSIONS [H × W × D]	34.1 in. × 18.1 in. × 9.6 in. (865 mm × 460 mm × 245 mm)	
OPERATING TEMPERATURE RANGE	Charge: 32 – 122°F (0 – 50°C) Discharging: -4 – 131°F (-20 – 55°C)	

*Less than 3 months of storage. If longer than 3 months, recommended storage temperature will be 59°F – 86°F (15°C - 30°C). Refer to section 5.4 for complete storage requirements.

MECHANICAL SPECIFICATIONS

PARAMETER	SPECIFICATION
WEIGHT	293.2 lbs. (133 kg)
ENCLOSURE RATING	IP20
MOUNTING OPTIONS	Floor mount/wall attached
DISPLAY/INDICATORS	LED Status
CONNECTOR TYPE	Degson quick connector/screw terminal

CERTIFICATIONS & COMPLIANCE

UL 1973	Yes
UL 9540	See https://eg4electronics.com/ for supported UL 9540 configurations
UL 9540A	Yes

WARRANTY & LIFECYCLE

CYCLE LIFE [70% EOL CAPACITY]*	10000 cycles @ 0.5C, 25°C, 80% DOD
DESIGN LIFE	10 years
WARRANTY	10 years or 10000 cycles
LIFETIME PRODUCTION**	122.2 MWh
APPLICATION TYPE	Residential/Commercial/Off-grid/Backup

*EG4 recommends this value be set no lower than 20% to maintain the recommended 80% Depth of Discharge.

** $(51.2V \times 314Ah / 1000 \times 80\% \times 10000 / 1000) \times 95\% = 122.2 \text{ MWh}$ or
 $(12861 \text{ kWh} \times 10000 \text{ cycles} \times 95\% \text{ efficiency}) = 122.2 \text{ MWh}$

2. ABBREVIATIONS

- AWG – American Wire Gauge
- A – Amps
- Ah – Amp hour(s)
- AC – Alternating Current
- AFCI – Arc-Fault Circuit Interrupter
- AHJ – Authority Having Jurisdiction
- kAIC – kilo-Amp Interrupting Capability
- ANSI – American National Standards Institute
- BAT – Battery
- BMS – Battery Management System
- COM – Communication
- CT – Current Transformer
- DC – Direct Current
- DIP – Dual In-line Package
- DOD – Depth of Discharge
- EG – Equipment Ground
- EGS – Equipment Grounding System
- EMC – Electromagnetic Compatibility
- EPS – Emergency Power System
- ESS – Energy Storage System
- E-Stop – Emergency Stop
- FCC – Federal Communication Commission
- GE – Grounding Electrode
- GEC – Grounding Electrode Conductor
- GFCI – Ground Fault Circuit Interrupter
- GFDI – Ground Fault Detector/Interrupter
- Imp – Maximum Power Point Current
- IEEE – Institute of Electrical and Electronic Engineers
- IP – Ingress Protection
- I_{sc} – Short-Circuit Current
- In-lbs. – Inch Pounds
- kW – Kilowatt
- kWh – Kilowatt-hour
- LCD – Liquid Crystal Display
- LFP – Lithium Iron Phosphate
- L1 – Line 1
- L2 – Line 2
- mm – Millimeters
- MPPT – Maximum Power Point Tracking
- mV – Millivolt
- N – Neutral
- NEC – National Electric Code
- NEMA – National Electrical Manufacturers Association
- NFPA – National Fire Prevention Association
- Nm – Newton Meters
- NOCT – Normal Operating Cell Temperature
- PC – Personal Computer
- PCB – Printed Circuit Board
- PE – Protective Earth
- PPE – Personal Protective Equipment
- PV – Photovoltaic
- RSD – Rapid Shut Down
- SCC – Standards Council of Canada
- SOC – State of Charge
- STC – Standard Testing Conditions
- UL – Underwriters Laboratories
- UPS – Uninterrupted Power Supply
- V – Volts
- VOC – Open-Circuit Voltage
- VMP – Voltage Maximum Power

3. BATTERY SAFETY

3.1 SAFETY INSTRUCTIONS

Before any work begins, carefully read all safety instructions, and always observe them when working on or with the battery. The system must be installed by qualified service personnel following the installation instructions, using appropriate practices, and in compliance with all applicable local electrical, building, fire, and utility codes or regulations. Consult with the local AHJ to obtain the proper permits and permissions before installation.

Incorrect installation may cause:

- *Injury or death to the installer, operator or third party*
- *Damage to the battery or other attached equipment*

3.2 IMPORTANT SAFETY NOTIFICATIONS



DANGER: Hazardous Voltage Circuits!

AVERTISSEMENT! Circuits à tension élevée!

There are various safety concerns that must be carefully observed before, during, and after the installation, as well as during future operation and maintenance. The following are important safety notifications for the installer and any end users of this product under normal operating conditions.

1. **Do not disassemble the battery.** Contact the distributor for any issues that need repair for more information and proper handling instructions. Incorrect servicing or re-assembly may result in a risk of electric shock or fire and void the warranty.
2. **The ESS uses DC current.** DC current can cause continuous muscle contraction in the case of electric shock and severe burns and fire if this product is mishandled.
3. Damage to the ESS or improper installation may cause arc flashing, which can cause serious damage, injury, or death.
4. **Beware of high battery current.** Ensure that the battery module breakers and/or on/off switches are in the “open” or “off” position before installing or working on the battery. Use a voltmeter to confirm there is no voltage present to avoid electric shock.
5. **Do not make any connections or disconnections to the system while the batteries are operating.** Damage to system components or risk of electrical shock may occur if working with energized batteries.
6. Make sure the batteries are properly grounded.
7. An installer should make sure to be well protected by reasonable and professional insulative equipment [e.g., personal protective equipment (PPE)].
8. Before installing, operating, or maintaining the system, it is important to inspect all existing wiring to ensure it meets the appropriate specifications and conditions for use.
9. Ensure that the battery and system component connections are secure and proper to prevent damage or injuries caused by improper installation.
10. Rupture of the battery and shorting of battery cells can cause the release of toxic gases and harmful electrolyte solutions.



WARNING: TO REDUCE THE RISK OF INJURY, READ ALL INSTRUCTIONS!

All work on this product (system design, installation, operation, setting, configuration, and maintenance) must be carried out by qualified personnel. To reduce the risk of electric shock, do not perform any servicing other than those specified in the operating instructions unless qualified to do so.

11. Read all instructions before commencing installation. For electrical work, follow all local and national wiring standards, regulations, and these installation instructions. All wiring should be in accordance with the National Electrical Code (NEC), ANSI/NFPA 70.
12. The battery and system can connect with the utility grid only if the utility provider permits. Consult with the local AHJ before installing this product for any additional regulations and requirements for the area.
13. All warning labels and nameplates on this battery should be clearly visible and must not be removed or covered.
14. The installer should consider the safety of future users when choosing the battery's correct position and location as specified in this manual.
15. Keep children away from touching or misusing the battery and relevant systems.

The battery is designed to stop charging when reaching the low temperature threshold of 32°F. If charging current is observed when the internal battery temperature is below 32°F, disconnect battery immediately and consult distributor.



WARNING!

Cancer And Reproductive Harm – See www.P65Warnings.ca.gov for more details.

DISCLAIMER

EG4® reserves the right to make changes to the material herein at any time without notice. Please refer to www.eg4electronics.com for the most updated version of our manuals/spec sheets.



TAKE THESE ADDITIONAL PRECAUTIONS DURING INSTALLATION/REPLACEMENT

Ensure that all precautions listed above have been taken prior to beginning the installation and observe these additional precautions during installation. Failure to take these precautions may result in serious injury or death:



- **Thermal Runaway:** *Immediately stop the installation, place battery in a safe state if possible, and move away from the battery if the battery:*
 - *begins to swell or bulge,*
 - *if you smell any unusual odors,*
 - *if you hear a hissing sound, or*
 - *if the battery begins to emit heat and/or smoke.*

Your battery may be experiencing thermal runaway, a dangerous condition that may cause fire or explosion. *Contact local fire department, Chemtrec 800-262-8200, and EG4 support.*



- **Electrical Shock:** *When installing/replacing the battery:*
 - *Ensure that the battery does not get wet.*
 - *Do not spray water or other liquids on the battery.*
 - *Do not perform the installation in conditions where dust, moisture, or other debris could enter the battery.*
 - *Avoid touching connections and components unless instructed to do so by this guide.*
 - *Do not leave the battery unattended during the installation without it being in a safe state. Do not touch, lean on, or lay tools on the battery or connections.*

If you are electrically shocked during installation, place battery in a safe state if possible, and seek immediate medical attention.



- **Ventilation Warning:** *When installing/replacing the battery:*
 - *Do not open the battery.*
 - *Do not attempt the installation/replacement if the battery is damaged.*

Lithium batteries may emit toxic gases when ruptured. Do not attempt to repair the battery in the case of rupture. Move outdoors in the case of rupture and seek professional assistance.



- **Electrolyte Exposure:** *When installing/replacing the battery:*
 - *Ensure that the battery is not damaged.*
 - *Do not attempt the installation/replacement if the battery is damaged.*

Lithium batteries contain a liquid electrolyte solution that is corrosive and damaging to skin and eyes. Exposure may occur in the case of damage to the battery. In the case of contact with skin or eyes, wash continuously with water for 15 minutes and seek immediate medical attention. Remove contaminated clothes immediately. In the case of ingestion, drink at least two glasses of water or milk, induce vomiting if unconscious, and seek immediate medical attention.

4. SÉCURITÉ DE LA BATTERIE

4.1 CONSIGNES DE SÉCURITÉ

Avant de commencer tout travail, lisez attentivement toutes les consignes de sécurité et respectez-les toujours lorsque vous travaillez sur ou avec la batterie. L'installation doit être conforme à toutes les normes et réglementations nationales ou locales applicables. Consultez l'autorité compétente locale et/ou le service public pour obtenir les permis et les autorisations appropriés avant l'installation.

Une installation incorrecte peut entraîner les effets suivants :

- *Blessure ou décès de l'installateur, de l'exploitant ou d'un tiers*
- *Domages à la batterie ou à tout autre équipement attaché*

4.2 NOTIFICATIONS DE SÉCURITÉ IMPORTANTES



DANGER: Circuits à haute tension!

Il existe divers problèmes de sécurité qui doivent être soigneusement observés avant, pendant et après l'installation, ainsi que lors de l'utilisation et de la maintenance futures. Ce qui suit sont des notifications de sécurité importantes pour l'installateur et tout utilisateur final de ce produit dans des conditions de fonctionnement normales.

1. **Ne démontez pas la batterie.** Contactez le distributeur pour tout problème nécessitant une réparation pour plus d'informations et des instructions de manipulation appropriées. Un entretien ou un remontage incorrect peut entraîner un risque d'électrocution ou d'incendie et annuler la garantie.
2. **Ne court-circuitez jamais les entrées CC.** Un court-circuit de la batterie peut entraîner un risque d'électrocution ou d'incendie et peut entraîner des blessures graves ou la mort et/ou des dommages permanents à l'appareil et/ou à tout équipement connecté.
3. **Soyez prudent lorsque vous travaillez avec des outils métalliques sur ou à proximité des batteries et des systèmes.** Le risque d'arcs électriques et/ou de court-circuit de l'équipement peut entraîner des blessures graves ou la mort et des dommages à l'équipement.
4. **Attention au courant de batterie élevé.** Assurez-vous que les disjoncteurs du module de batterie et/ou les interrupteurs marche/arrêt sont en position « ouvert » ou « arrêt » avant d'installer ou de travailler sur la batterie. Utilisez un voltmètre pour confirmer qu'il n'y a pas de tension présente afin d'éviter les chocs électriques.
5. **N'effectuez aucune connexion ou déconnexion du système pendant que les batteries fonctionnent.** Des dommages aux composants du système ou un risque d'électrocution peuvent survenir si vous travaillez avec des batteries sous tension.
6. Assurez-vous que le banc de batteries est correctement mis à la terre.
7. Un installateur doit s'assurer d'être bien protégé par un équipement isolant raisonnable et professionnel [par exemple, un équipement de protection individuelle (EPI)].
8. Avant d'installer, d'utiliser ou d'entretenir le système, il est important d'inspecter tout le câblage existant pour s'assurer qu'il répond aux spécifications et aux conditions d'utilisation appropriées.
9. Assurez-vous que les connexions de la batterie et des composants du système sont sécurisées et appropriées pour éviter les dommages ou les blessures causés par une mauvaise installation.
10. La rupture de la batterie et le court-circuit des cellules de la batterie peuvent causer la libération de gaz toxiques et de solutions électrolytiques nocives.



AVERTISSEMENT : Pour réduire le risque de blessure, lisez toutes les instructions !

Tous les travaux sur ce produit (conception du système, installation, fonctionnement, réglage, configuration et maintenance) doivent être effectués par du personnel qualifié. Pour réduire le risque d'électrocution, n'effectuez aucun entretien autre que ceux spécifiés dans le mode d'emploi, à moins d'être qualifié pour le faire.

11. Lisez toutes les instructions avant de commencer l'installation. Pour les travaux électriques, suivez toutes les normes de câblage locales et nationales, les réglementations et ces instructions d'installation. Tout le câblage doit être conforme au Code national de l'électricité (NEC), ANSI/NFPA 70.
12. La batterie et le système ne peuvent se connecter au réseau public que si le fournisseur d'électricité l'autorise. Consultez l'AHJ local avant d'installer ce produit pour connaître les réglementations et exigences supplémentaires de la région.
13. Toutes les étiquettes d'avertissement et les plaques signalétiques de cette batterie doivent être clairement visibles et ne doivent pas être retirées ou couvertes.
14. L'installateur doit tenir compte de la sécurité des futurs utilisateurs lors du choix de la position et de l'emplacement corrects de la batterie, comme spécifié dans ce manuel.
15. Tenez les enfants à l'écart de la batterie et des systèmes concernés ou de les utiliser à mauvais escient.

La batterie est conçue pour arrêter de se charger lorsqu'elle atteint le seuil bas de 32 °F. Si un courant de charge est observé lorsque la température interne de la batterie est inférieure à 32 °F, débranchez immédiatement la batterie et consultez le distributeur.



AVERTISSEMENT !

Cancer et dommages reproductifs – Voir www.P65Warnings.ca.gov pour plus de détails.

DISCLAIMER

EG4® se réserve le droit de modifier le contenu de ce document à tout moment sans préavis. Veuillez consulter www.eg4electronics.com pour la version la plus récente de nos manuels/fiches techniques.



PRENEZ CES PRÉCAUTIONS SUPPLÉMENTAIRES LORS DE L'INSTALLATION OU DU REMPLACEMENT

Assurez-vous que toutes les précautions énumérées ci-dessus ont été prises avant de commencer l'installation et respectez ces précautions supplémentaires pendant l'installation. Le non-respect de ces précautions peut entraîner des blessures graves ou la mort.



- **Emballement thermique:** Arrêtez immédiatement l'installation, mettez la batterie dans un état sécuritaire si possible et éloignez-vous de la batterie si celle-ci :
 - commence à gonfler ou à se déformer,
 - dégage des odeurs inhabituelles,
 - émet un sifflement, ou
 - commence à dégager de la chaleur et/ou de la fumée.

La batterie peut être en situation d'emballement thermique, une condition dangereuse pouvant entraîner un incendie ou une explosion.

Communiquez avec le service d'incendie local, Chemtrec au 800-262-8200, et le soutien EG4.



- **Choc électrique:** Lors de l'installation ou du remplacement de la batterie :
 - Assurez-vous que la batterie ne soit pas mouillée.
 - Ne vaporisez pas d'eau ni d'autres liquides sur la batterie.
 - N'effectuez pas l'installation dans des conditions où de la poussière, de l'humidité ou d'autres débris pourraient pénétrer dans la batterie.
 - Évitez de toucher les connexions et les composants sauf indication contraire dans ce guide.
 - Ne laissez pas la batterie sans surveillance pendant l'installation si elle n'est pas dans un état sécuritaire
 - Ne touchez pas la batterie, ne vous appuyez pas dessus et ne déposez pas d'outils sur la batterie ou les connexions.

En cas de choc électrique pendant l'installation, mettez la batterie dans un état sécuritaire si possible et consultez immédiatement un professionnel de la santé.



- **Avertissement – Ventilation:** Lors de l'installation ou du remplacement de la batterie :
 - N'ouvrez pas la batterie.
 - N'effectuez pas l'installation ou le remplacement si la batterie est endommagée.

Les batteries au lithium peuvent émettre des gaz toxiques en cas de rupture. N'essayez pas de réparer la batterie si elle est rompue. En cas de rupture, déplacez-vous à l'extérieur et demandez l'assistance d'un professionnel qualifié.



- **Exposition à l'électrolyte :** Lors de l'installation ou du remplacement de la batterie :
 - Assurez-vous que la batterie n'est pas endommagée.
 - N'effectuez pas l'installation ou le remplacement si la batterie est endommagée.

Les batteries au lithium contiennent une solution d'électrolyte liquide corrosive et nocive pour la peau et les yeux. Une exposition peut survenir si la batterie est endommagée. En cas de contact avec la peau ou les yeux, rincez abondamment à l'eau pendant 15 minutes et consultez immédiatement un professionnel de la santé. Retirez immédiatement les vêtements contaminés. En cas d'ingestion, buvez au moins deux verres d'eau ou de lait, provoquez le vomissement si la personne est consciente, et consultez immédiatement un professionnel de la santé.

SYMBOLS USED IN MANUAL



WARNING:

This type of notation indicates that a hazard may pose a risk to human health and safety.



DANGER:

This type of notation indicates a severe hazard that presents an immediate risk of serious injury or death.



NOTE:

This type of notation indicates useful information.



IMPORTANT:

This type of notation indicates that the information provided is important for the installation, operation, and/or maintenance of the equipment. Failure to follow the recommendations in such a notation could result in the equipment warranty being voided.



CAUTION:

This type of notation indicates that the hazard could potentially damage the equipment.



REMINDER:

This type of notation indicates previously stated information that should be considered to ensure proper operation and safety.

SYMBOLS USED ON EQUIPMENT

	<p>WARNING: Read the instructions before installation, operation, and maintenance of the system.</p>
	<p>WARNING: Read the instructions before installation, operation, and maintenance of the system.</p>
	<p>WARNING: Hazardous Voltage Circuits</p>

SYMBOLES UTILISÉS DANS LE MANUEL



AVERTISSEMENT :

Ce type de signalisation indique qu'un danger peut présenter un risque pour la santé et la sécurité humaines.



DANGER :

Ce type de signalisation indique un danger grave présentant un risque immédiat de blessures graves, voire mortelles.



NOTE :

Ce type de notation indique des informations utiles.



IMPORTANT :

Ce type de notation indique que les informations fournies sont importantes pour l'installation, le fonctionnement et/ou l'entretien de l'équipement. Le non-respect des recommandations figurant dans cette notation pourrait entraîner l'annulation de la garantie de l'équipement.



PRUDENCE :

Ce type de notation indique que le danger pourrait potentiellement endommager l'équipement.



RAPPEL :

Ce type de notation indique des informations précédemment mentionnées qui doivent être prises en compte pour garantir un fonctionnement et une sécurité optimaux.

SYMBOLES UTILISÉS SUR L'ÉQUIPEMENT



AVERTISSEMENT :

Lisez les instructions avant l'installation, l'utilisation et l'entretien du système.



AVERTISSEMENT :

Lisez les instructions avant l'installation, l'utilisation et l'entretien du système.



AVERTISSEMENT :

Circuits à tension dangereuse.

5. PRODUCT OVERVIEW

The EG4® WallMount 314Ah Indoor Battery is ideal for indoor low voltage residential energy storage applications. The batteries use lithium iron phosphate cells with the highest safety performance and an intelligent Battery Management System (BMS) that can monitor and record the voltage, current, and temperature of each cell in real-time. The BMS also contains additional features and protections such as active cell balancing, advanced battery control methods, additional safety features, and more.

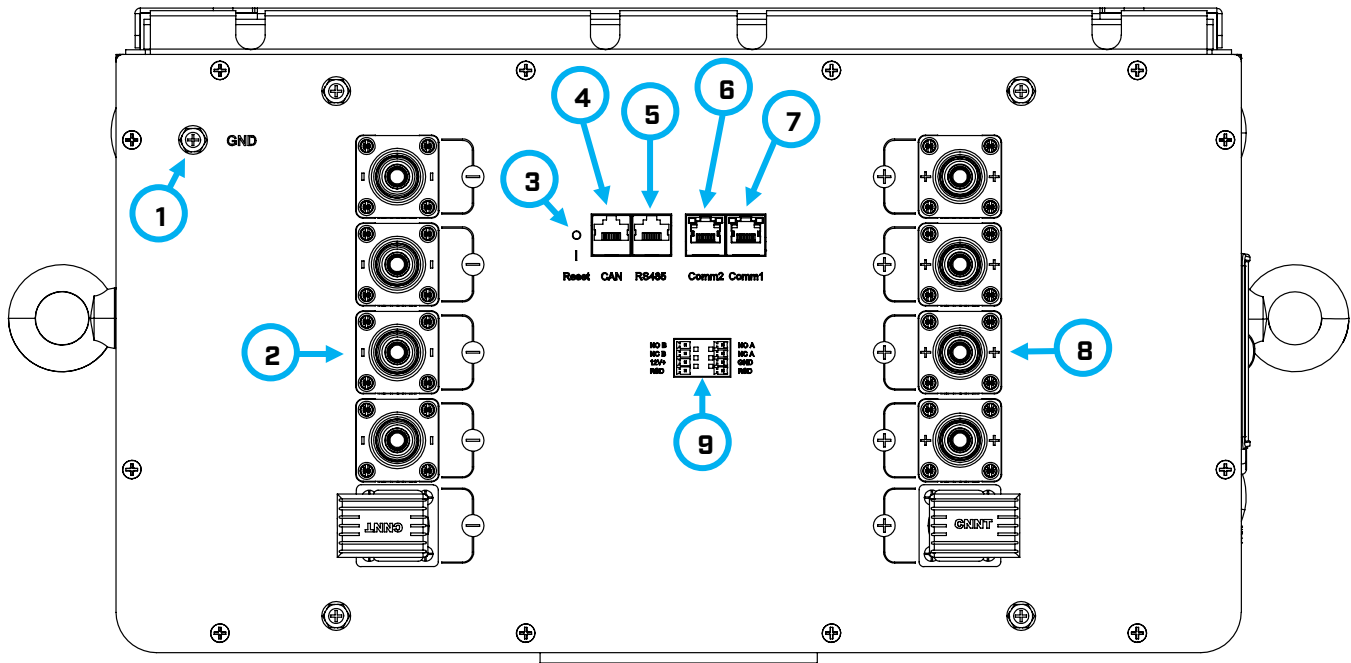

NO.	ITEM	DESCRIPTION	REMARKS
1	GND	Equipment Grounding Conductor (EGC)	For grounding the battery
2	Terminal	Negative × 5	250A rated Degson battery connector
3	Reset	BMS Reset Button	-
4	CAN	CAN Communication Interface	For inverter communications
5	RS485	RS485 Communication Interface	For inverter communications
6	Battery Comm 2	Battery communication Paralleling	For multiple batteries in parallel
7	Battery Comm 1	Battery communication Paralleling	For multiple batteries in parallel
8	Terminal	Positive × 5	250A rated Degson battery connector
9	Dry Contact	Normally Closed, Normally Open, Ground, RSD, 12V	For RSD control

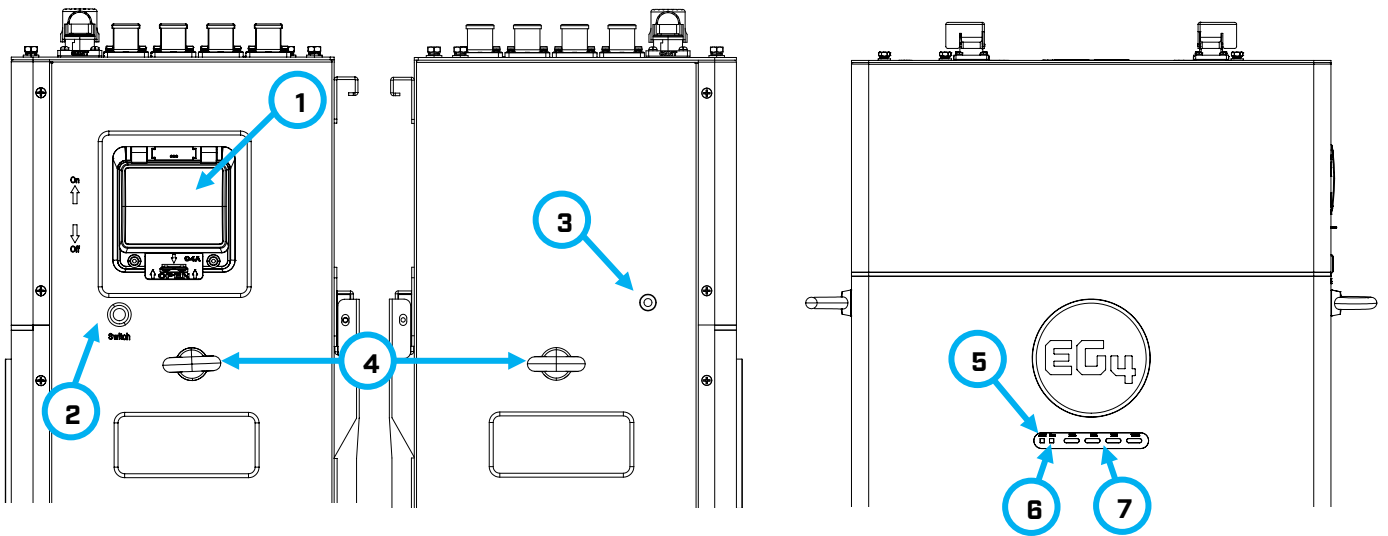

NO.	ITEM	DESCRIPTION	REMARKS
1	Breaker	Output switch and over current protection	-
2	ON/OFF Switch	Turn BMS on/off	-
3	Wi-Fi/Bluetooth Antenna	Network Connection	-
4	Lifting Eye Bolt	Threaded bolt with circular eye	For moving the battery
5	ALM	Alarm LED Display	To show alarm status
6	RUN	Run LED Display	To show normal operating status
7	SOC	State Of Charge Display	To show battery charge. Each LED indicates 25%

5.1 BATTERY DIMENSIONS

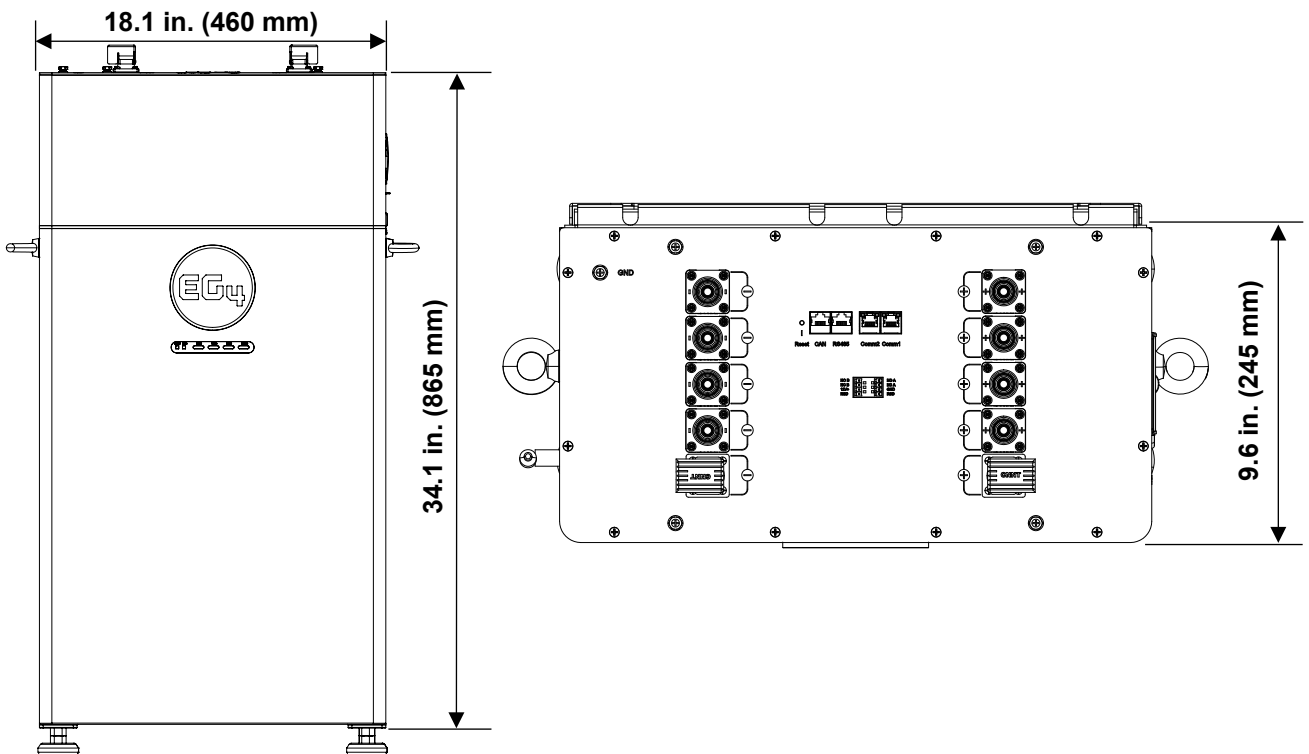

5.2 PACKING LIST

The items listed below will arrive with the product shipment:

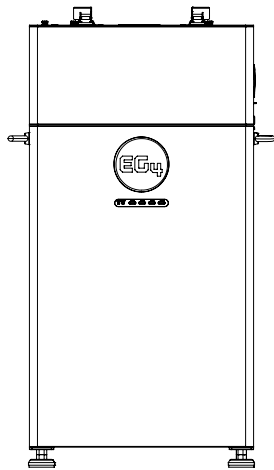

EG4 WallMount 314Ah Indoor Battery (x1)

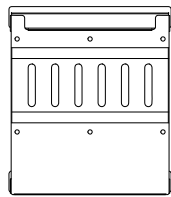

Mounting Bracket (x1)
(Will come attached to the back of the battery)

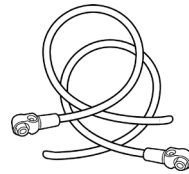

Red and Black Degson power cables (2 set each)
2/0 AWG (39.4 in.)



M10 Lifting Eye Bolt (x2)

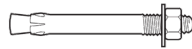

Expansion Bolt (x6)
M8*70



Battery to Inverter Communication Cable (x1)
(59.1 in.)

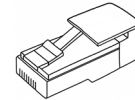

120Ω Terminating Resistor



Wi-Fi/Bluetooth Antenna

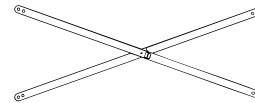

X-Bracket



DANGER:

When installing or removing the battery, confirm the battery is powered off and use a multimeter to confirm there is no voltage present. This will prevent users from encountering live (powered) terminals by accident.

5.3 BMS OVERVIEW

The Battery Management System (BMS) is intended to safeguard the battery and battery cells against a variety of situations that could damage system components. The BMS utilizes a 157A rated charge and 200A rated discharge limit which also aids in keeping the battery and battery cells operational for a greater number of life cycles. Each EG4® WallMount 314Ah Indoor Battery is specifically configured to ensure peak performance and operation with any system.

PCB TEMPERATURE PROTECTION

The BMS will ensure that the Printed Circuit Board (PCB) does not overheat. This component houses most of the “brains” of the battery. This feature will turn off the battery if it begins to overheat.

VOLTAGE PROTECTION

The BMS is designed to continuously monitor the voltage of each individual cell and ensure that they are not over or undercharged.

ACTIVE CELL BALANCE PROTECTION

Cell balancing ensures that each individual cell within the battery maintains a specific voltage range relative to the others. This process is essential for optimizing the battery's performance and longevity and is carried out automatically without the need for manual intervention.

ENVIRONMENTAL TEMPERATURE PROTECTION

It may be dangerous to attempt using the battery in temperatures outside of the environmental parameters provided on the spec sheet. Continued operation in these conditions may result in permanent damage to the battery module and its components. To prevent this, the BMS is designed to measure the temperature while charging/discharging and will shut down the battery to prevent damage. See section 1 for battery charging/discharging temperature ranges.

CURRENT PROTECTION

The BMS is designed to constantly monitor the charge/discharge amperage and has built in safeguards against exceeding specific parameters. These include built-in timers that shut off quickly in the event of short circuits or extremely high amperage and delayed shut down for amperage that is slightly above the maximum capacity.

5.4 STORAGE INFORMATION

There are a few steps to be taken to ensure that batteries are stored safely and in a state that will ensure they are not damaged during storage.

BATTERY STATE

The State of Charge (SOC) of the battery when placed into storage will affect how long the battery maintains its SOC. EG4® recommends that each battery is brought to a 20 – 50% SOC before placing it in storage. Lithium batteries will lose a certain percentage of their total charge while in storage, depending on how long they are stored and the conditions they are stored in. EG4 recommends charging/discharging the batteries every 3 months for best performance.

ENVIRONMENTAL FACTORS

The storage location for the battery can greatly affect the health of the battery. **For best results**, the temperature should remain moderate, between 32°F – 113°F (0°C – 45°C) up to three months. If stored longer than three months, the recommended temperature range is 59°F – 86°F (15°C – 30°C).

If storage time of the cell exceeds 6 months, the SOC of the cell needs to be adjusted to 20 – 50% SOC by a charge and discharge process, humidity is less than or equal to 90% RH, and the recommended storage temperature is 41°F – 77°F (5°C – 25°C).

Keep the battery away from locations where it may get wet or locations with high humidity (≥90%).
Store the batteries away from combustible materials!

5.5 BATTERY PERFORMANCE CURVES

Charge & Discharge curve with 0.5C @ 25°C

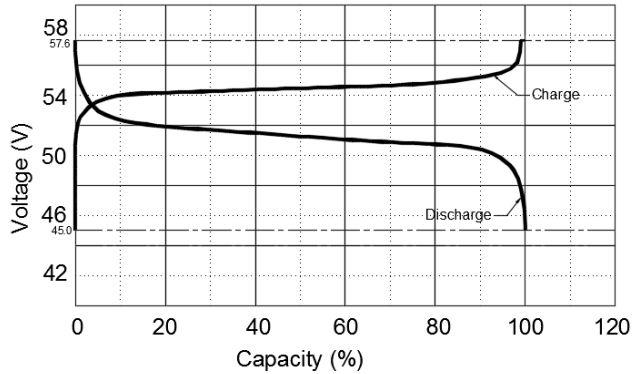

Discharge performance with different rate @ 25°C

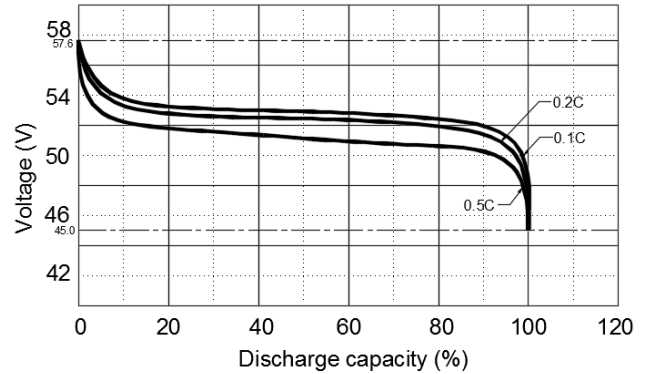

Discharge capacity with different temperature @ 0.5C

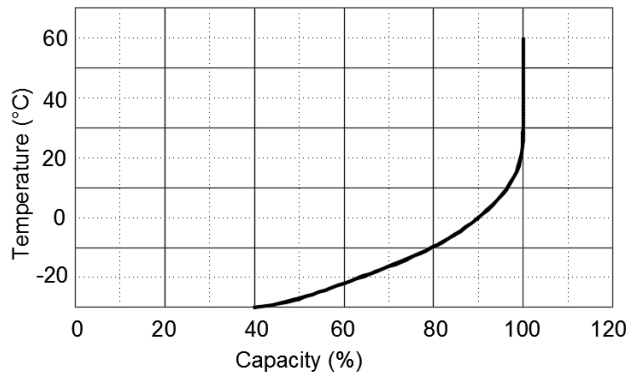

Cycle life with DOD @ 0.5C, 25°C

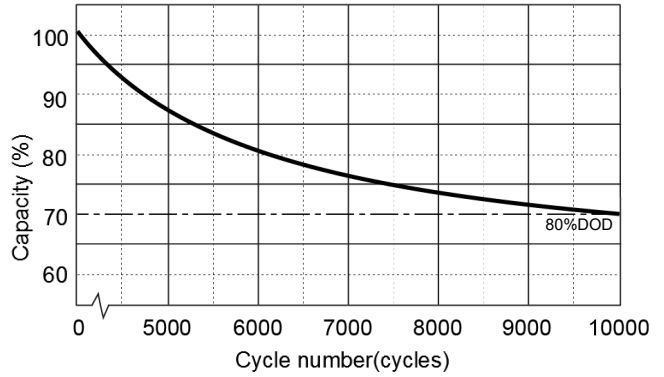

Self-discharge @ different temperature

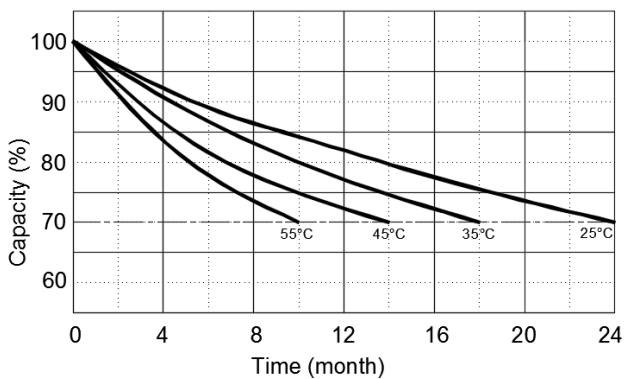

5.6 BATTERY CHARGING

Ensure the proper settings are set on the charge controller and/or inverter being used to avoid overcharging or damaging the module. (Refer to Section 1: Technical Specifications for a full list of charging/discharging parameters.)

It is normal for EG4® WallMount 314Ah Indoor batteries that have their own BMS and are wired in parallel to demonstrate a wide variety of SOC readings during any given charge or discharge cycle. Variations of up to 10% are common. For more information on Battery State of Health (SOH) & Depth of Discharge (DoD), scan the QR code below:



This is not a cause for concern or indication that the module is providing less than the maximum capacity. This can be caused by even slight variations in wiring resistance to each battery, internal resistance, temperature differences, and even variations in each cell. Even a slight variation causes one battery to take more of the load or charge for a short time. Over the duration of the discharge or charge cycle, this will balance out with the lagging battery then taking the load or charge at the other end of the cycle resulting in recovering the full listed kWh capacity of the pack. The voltage differences created as batteries diverge in SOC will eventually cause them to converge at some point in the cycle.



NOTE:

When installing multiple batteries or adding a battery to an existing bank, confirm all batteries are charged to 100% before paralleling. This step is crucial to optimizing battery performance.

5.7 FRONT PANEL INDICATOR LIGHTS

The WallMount 314Ah Indoor Battery features two status and four State of Charge (SOC) indicator LED lights on the front panel of the unit. Their functions are listed below:



1. **ALM** – The ALM light indicates a static, red color and powers on when a fault occurs. Please refer to section 10 for more information on specific faults and required actions.
2. **Run** – The Run light will indicate a solid, green color when the battery is in an idle state. When the battery is either charging or discharging, the light will indicate a blinking, green color.
3. **25%/50%/75%/100%** – The SOC indicator lights display charge level in 25% increments. A red 25% light indicates 0 – 15% SOC, while a green 25% light indicates 16 – 25%. A green 50% light with all preceding lights green indicates 26 – 50% SOC. A green 75% light with all preceding lights green indicates 51 – 75% SOC. A green 100% light with all preceding lights green indicates 76 – 100% SOC.



NOTE:

See section 10.1 for full LED indicator status and definition.

6. GENERAL INSTALLATION

This section provides detailed steps for installing and configuring the battery. It is recommended to complete each section in order as listed below:

INSTALLATION STEPS

- 6.1 Recommended Tools
- 6.2 Location Requirements
- 6.3 Battery Installation
- 6.4 Battery and Conduit Box
- 6.5 Battery and Conduit Box with EG4® 18kPV
- 6.6 Battery and Conduit Box with EG4® 12kPV/FlexBOSS18/21

6.1 RECOMMENDED TOOLS



Safety Goggles



Dielectric Shoes



Gloves



Multimeter



Phillips Head
Screwdriver

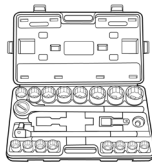

Socket Set



Electric Drill and
Drill Bits



Flathead
Screwdriver

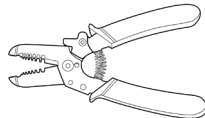

Wire Stripper



Level

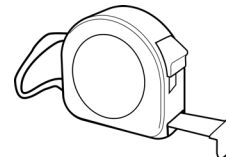

Tape Measure

6.2 LOCATION REQUIREMENTS

Requirements for installation location:

- The EG4® WallMount 314Ah Indoor Battery is heavy. Use an equipment lift or the team-lift technique to move the battery.
- The battery is designed to be installed indoors. Units used for indoor residential use are only intended to be installed in attached or detached garages, sheds, enclosed utility closets, basements, storage or utility spaces within dwelling units. Units are not intended for installation in habitable or living spaces within dwelling units and are not intended for installation near marine environments.
- The battery can be installed against a flat wall, but the weight of the battery should not be fully supported by the wall. To help with this requirement the battery comes with pre-installed feet that should be used to allow some of the weight of the battery to rest on the ground.
- When installing on flat ground, ensure there is proper drainage on the ground surrounding the install location to help prevent potential damage from flooding.
- Based on UL 9540A testing, the manufacturer's recommended minimum spacing between WallMount 314Ah Indoor batteries is 4 in. (See Intertek/ETL Test Report 251120146GZC-001). Consult the AHJ prior to installation to see if they allow reduced spacing between the batteries. If not, follow the applicable state or local building and/or fire code spacing requirements.
- Make sure that the installation location maintains a minimum clearance of 23.6 in. (600 mm) from all exposures and egress points.
- Verify the battery is installed upright.
- Consult state and local building, fire, and installation codes for applicable smoke alarm requirements.



IMPORTANT:

Ensure a minimum installation space volume of 50 m³, if not ventilated. This ensures flammable gas stays below 25% of the Lower Flammable Limit (LFL) in case of thermal runaway. Room volume is based on released gases and the number of battery cells affected during testing. Adding more EG4® WallMount 314Ah Indoor batteries does not require a larger installation location, as tests showed no propagation between units. Required installation volume may be reduced with proper ventilation per code and jurisdictional requirements.



NOTE:

The battery is very heavy. Use the team-lift technique during installation.



WARNING:

Do not make any electrical connections until the battery is in its final location.

6.3 BATTERY INSTALLATION



NOTE:

When using an equipment lift to move the battery, attach the M10 lifting eye bolts to both sides of the battery.

1. Remove the four set screws holding the mounting bracket to the back of the battery and set them to the side.
2. Remove the mounting bracket from the battery and set it to the side.

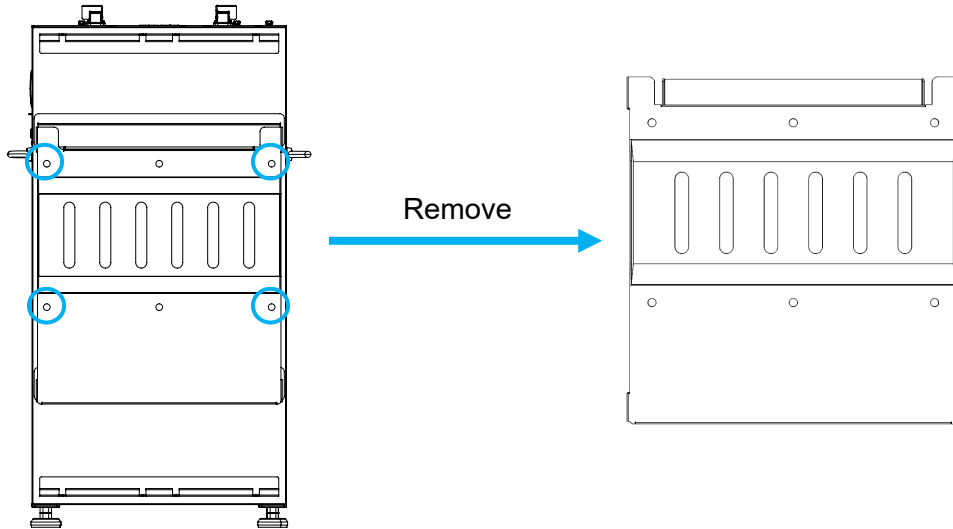

3. Position the top of the mounting bracket on the wall at the desired mounting height with a minimum clearance from the ground of 29 in. (736.6 mm).

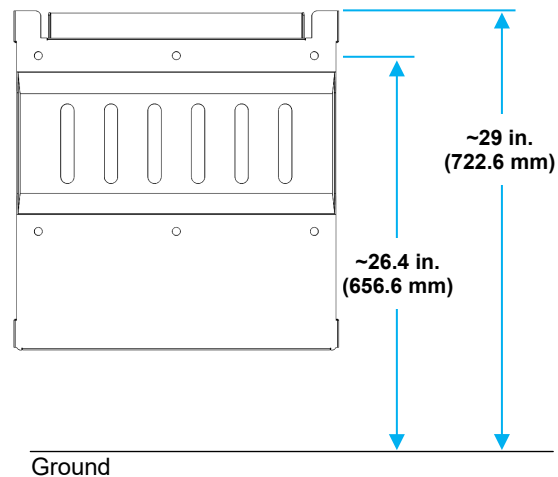

- Using a level, ensure the bracket is level with the ground and drill six holes to accommodate the mounting hardware used.

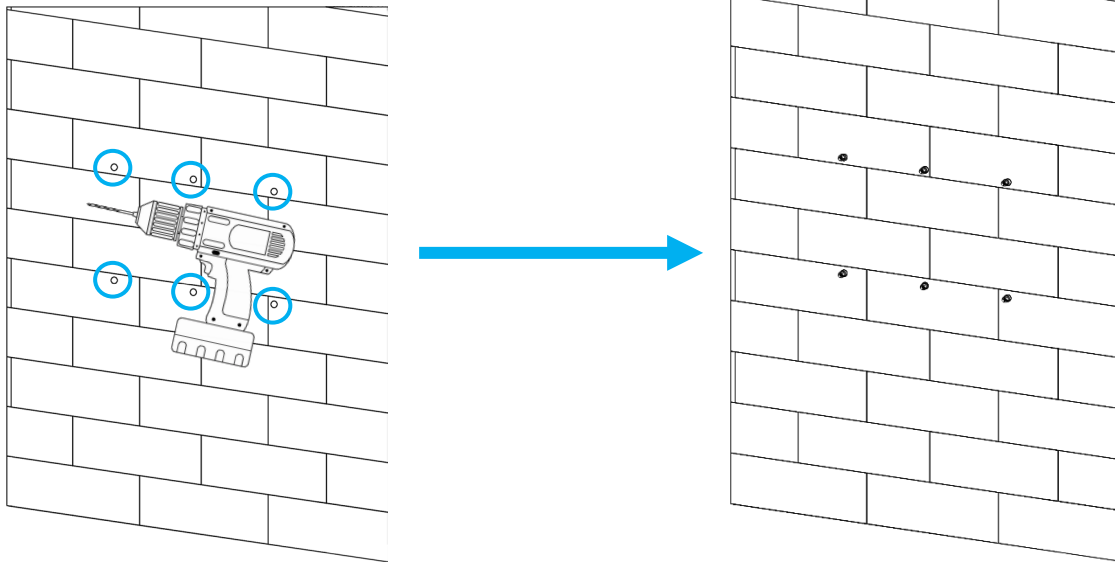

- Secure the mounting bracket to the wall using the appropriate hardware required for the mounting surface. Use the included expansion bolts for concrete or brick mounting.

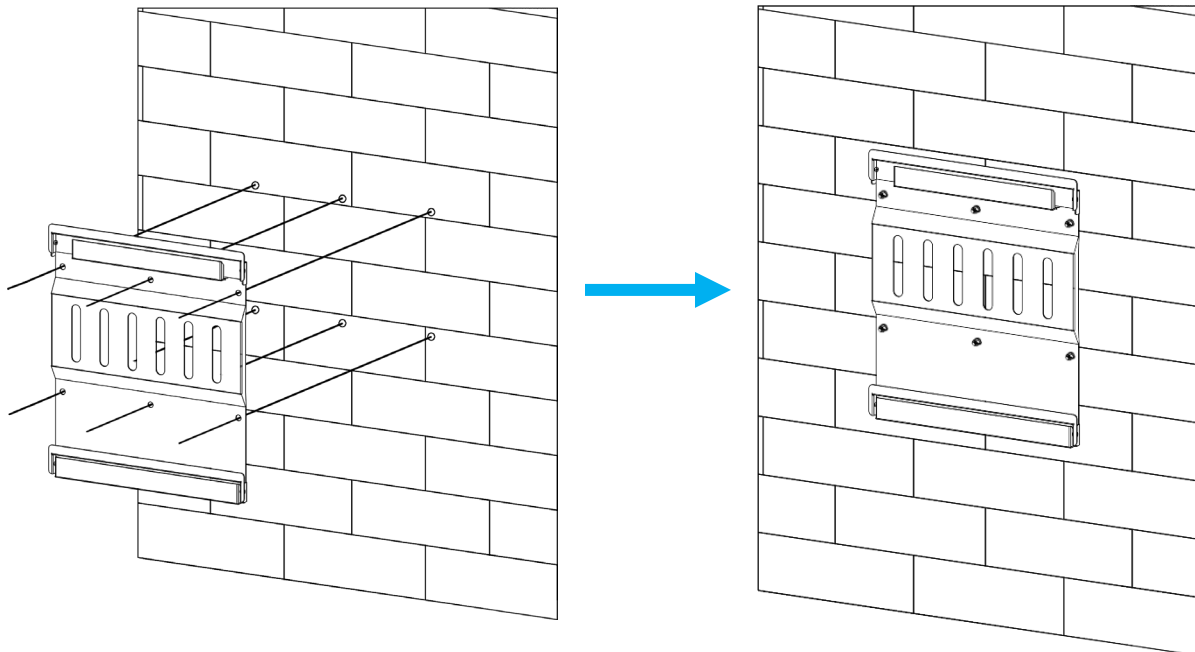

6. Attach the battery to the mounting bracket. Using the team-lift technique, lift the battery and hook the back flange of the battery onto the front flange of the mounting bracket.



CAUTION:

The battery is very heavy. Utilize the team-lift technique to avoid injury to personnel or damage to equipment. The battery's weight is supported by the feet, not the wall bracket. Verify the feet are firmly positioned on the ground.

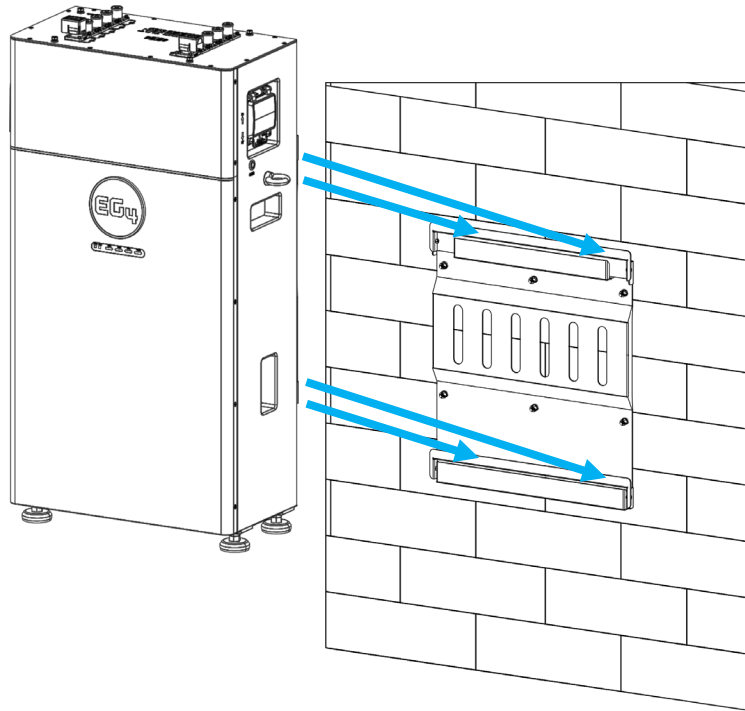

7. Secure the battery to the mounting bracket using the four included side screws from Step 1.

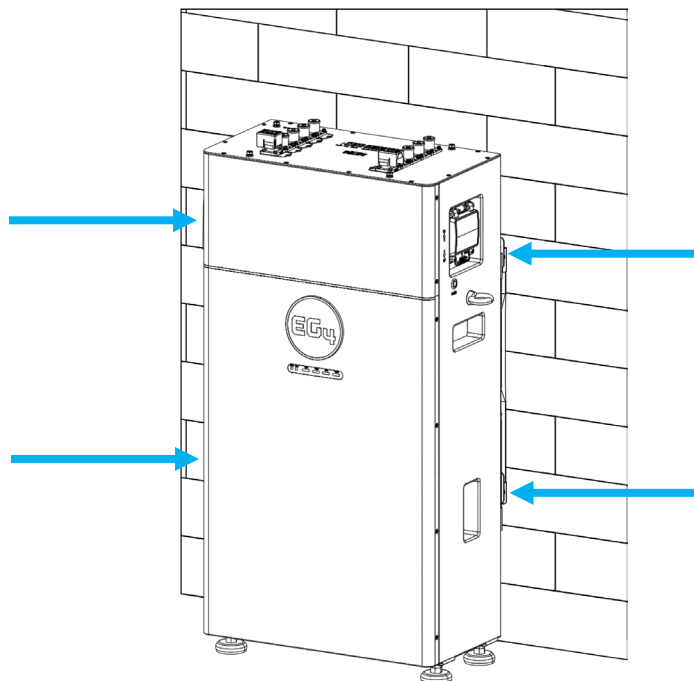

8. Once the battery is secured, attach the Wi-Fi/Bluetooth antenna onto the left side of the battery.

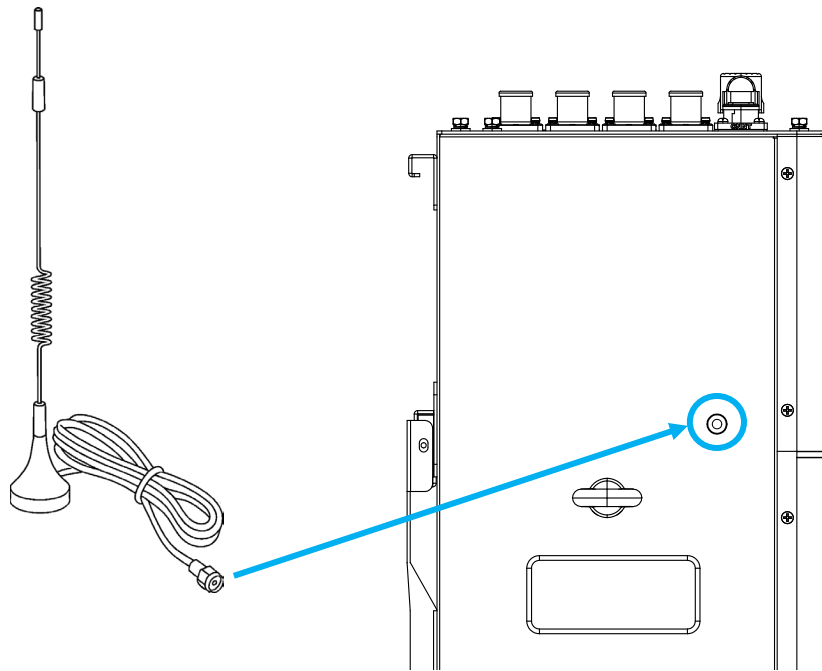

6.4 BATTERY WITH CONDUIT BOX

When installing the battery with the optional Indoor Buildable conduit box, follow the steps below continuing from step 8 in the previous section. Maintain 4 in. (101.6 mm) of clearance on both sides of the battery. Leave the front cover of the conduit box off until the assembly is fully complete.

1. Remove the four screws on the top of the battery as shown in the image below and retain them for use in step 2.

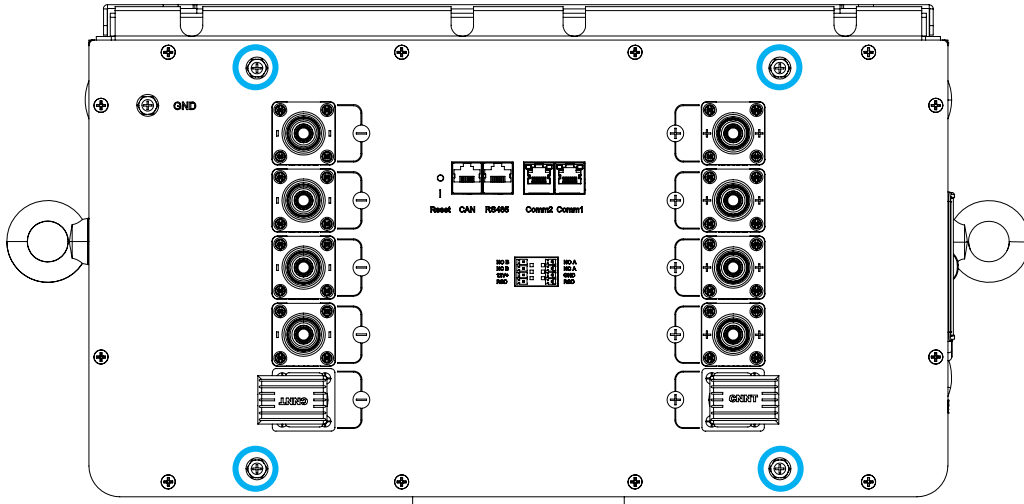

NOTE:

Refer to the EG4® Indoor Buildable Conduit Box quick start guide at www.eg4electronics.com for assembly instructions or scan the QR code below.



2. Identify the four screw locations on the bottom of the Indoor Buildable conduit box that line up with the screw holes on top of the WallMount 314Ah Indoor Battery. Place the conduit box on top of the battery and use the screws from step 1 to attach the box to the top of the battery.

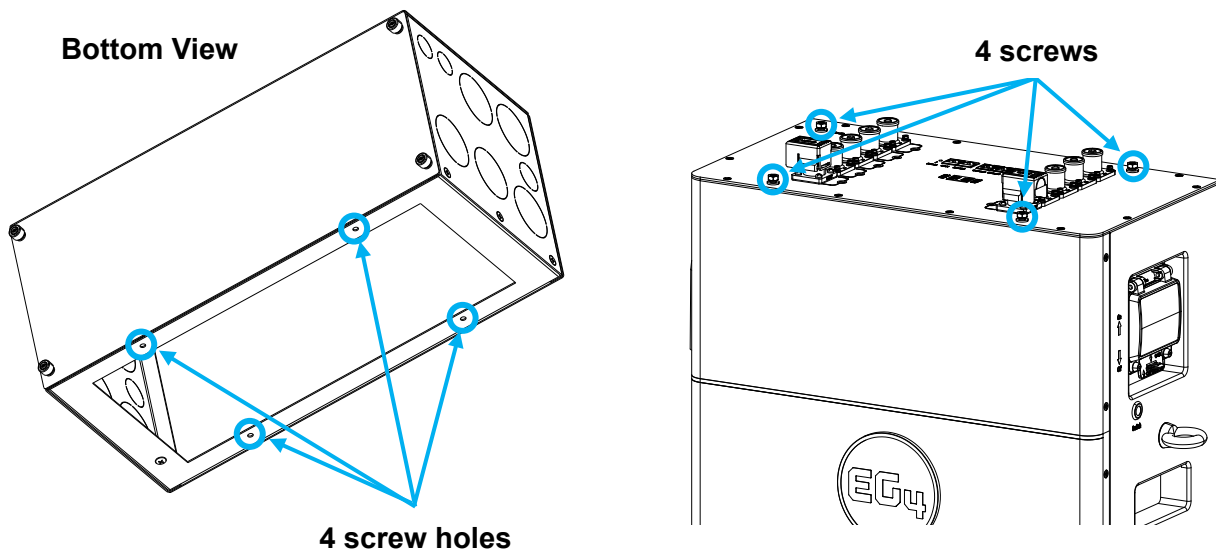

3. Finally, attach the grounding conductor from the conduit box to the M6 grounding screw on top of the battery to the Equipment Grounding System to properly ground the battery.

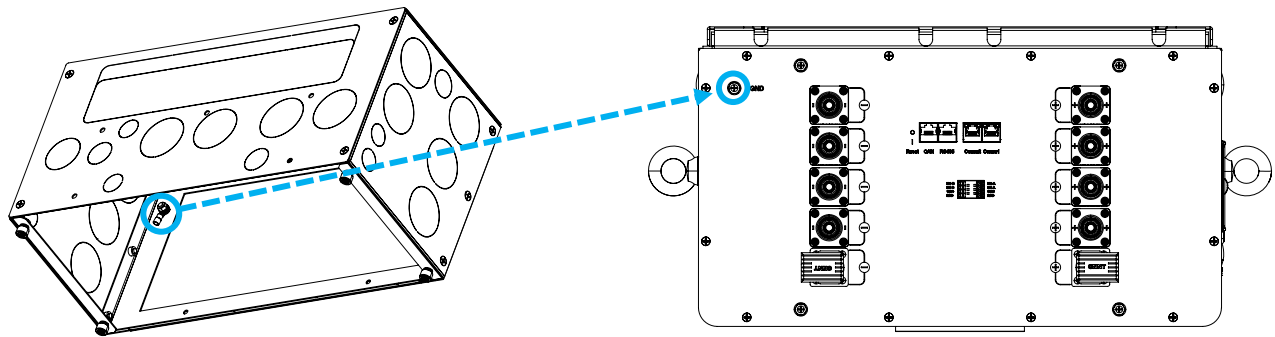

The image below represents a complete install:

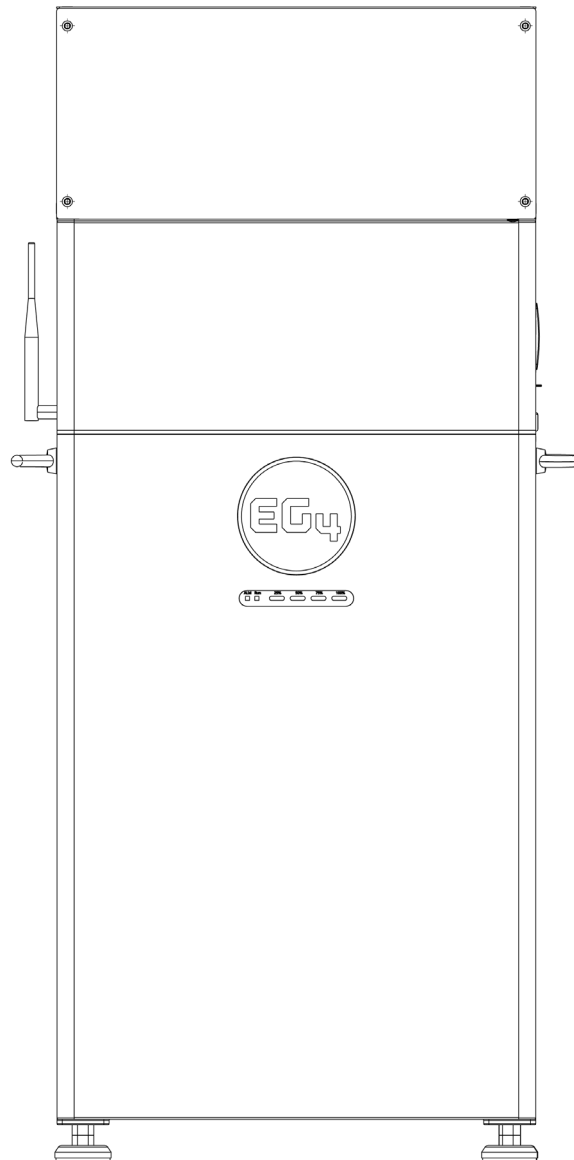

6.5 BATTERY, CONDUIT BOX, & 18KPV

Upon completing step 3 in section 6.4, proceed with the following instructions to install with an 18kPV inverter and Indoor Buildable conduit box:

1. Align the included x-bracket with the drilled holes and mount the battery bracket and x-bracket to the wall, with the x-bracket against the wall.
2. Using the uppermost hole on the x-bracket, attach the inverter mounting bracket using the appropriate hardware for the mounting surface. See the inverter user manual for more information.
3. Attach the battery to the mounting bracket. Use the team-lift technique to secure the battery on the bracket's flanges.
4. Attach the conduit box to the battery. See section 6.4 for installation instructions.
5. Install the 18kPV onto the inverter mounting bracket (included with inverter) making sure the holes of the inverter align with the conduit box and secure to each other using the included hardware.
6. Finally, properly ground the battery by attaching the grounding conductor from the conduit box to the M6 grounding screw on top of the battery.

Images for representative purposes only.

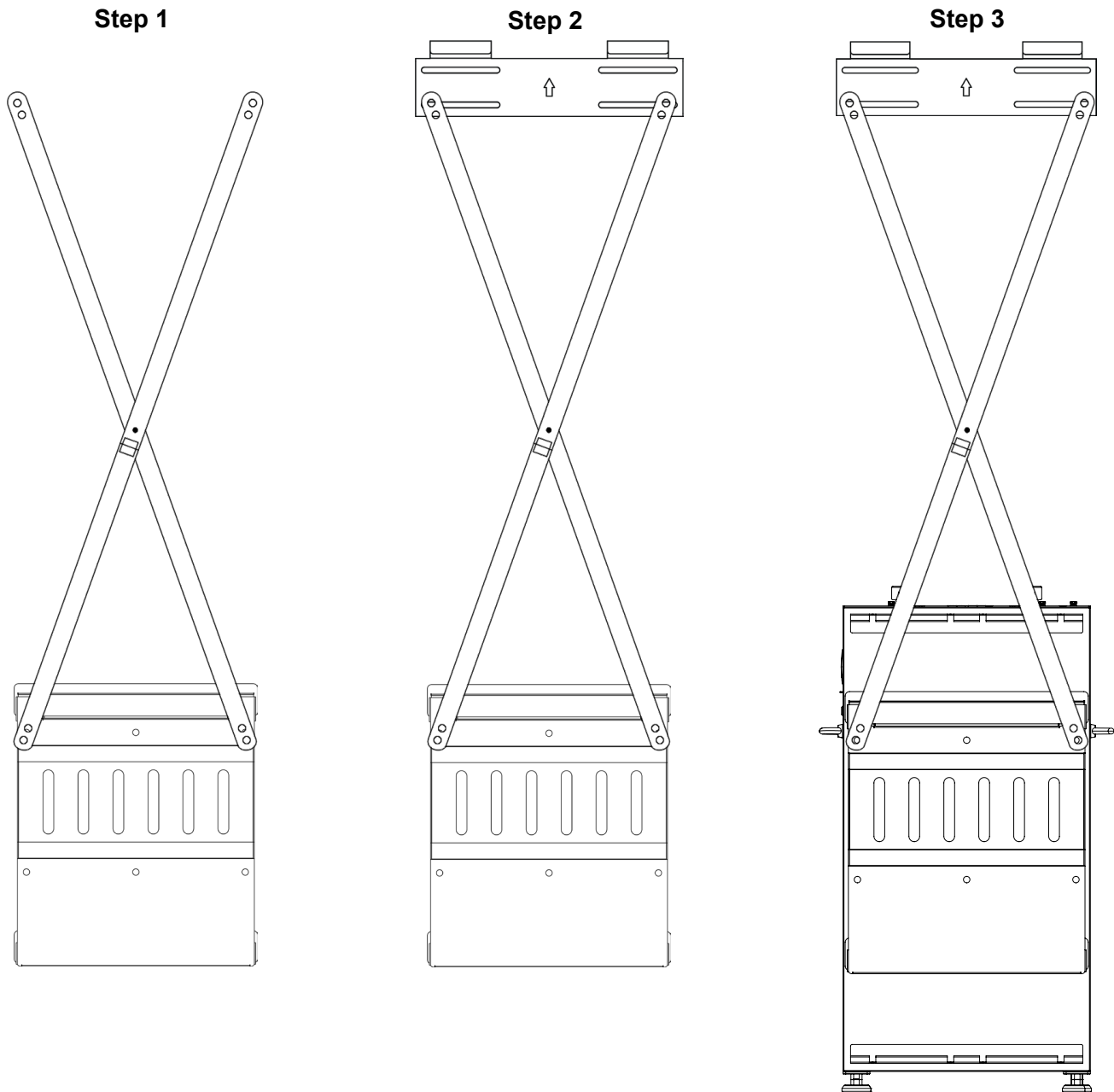

Images for representative purposes only.

Step 4

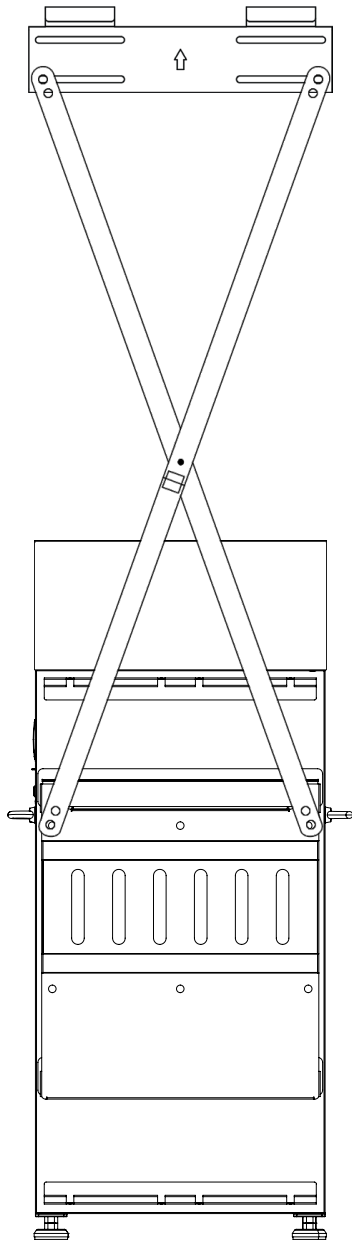

Step 5

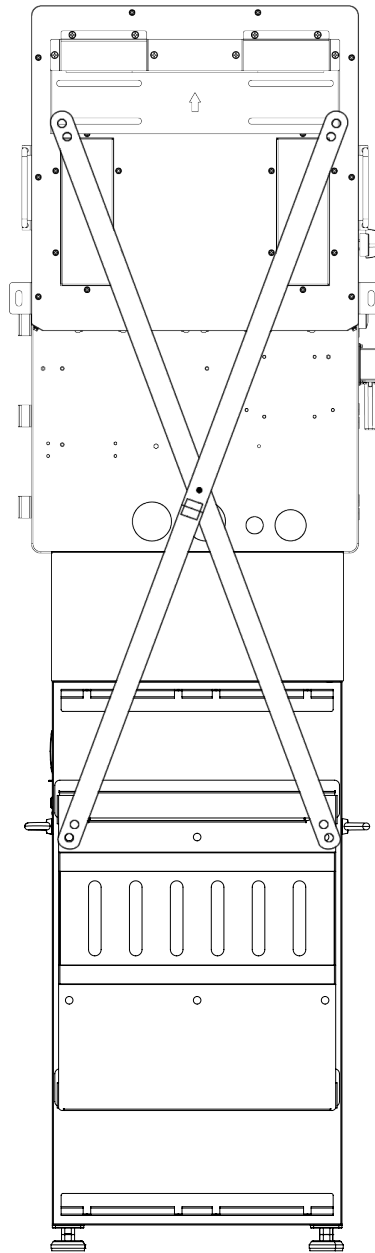

6.6 BATTERY, CONDUIT BOX, & 12KPV/FLEXBOSS18/21

Upon completing step 3 in section 6.4, proceed with the following instructions to install with a 12kPV, FlexBOSS18, or FlexBOSS21 inverters along with the indoor buildable conduit box:

1. Align the included x-bracket with the drilled holes and mount the battery bracket and x-bracket to the wall, with the x-bracket against the wall.
2. Using the lowermost hole on the x-bracket, attach the inverter mounting bracket using the appropriate hardware for the mounting surface. See the inverter user manual for more information.
3. Attach the battery to the mounting bracket. Use the team-lift technique to secure the battery on the bracket's flanges.
4. Attach the conduit box to the battery. See section 6.4 for installation instructions.
5. Install the respective inverter onto the inverter mounting bracket (included with inverter) making sure the holes of the inverter align with the conduit box and secure to each other using the included hardware.
6. Finally, properly ground the battery by attaching the grounding conductor from the conduit box to the M6 grounding screw on top of the battery.

Images for representative purposes only.

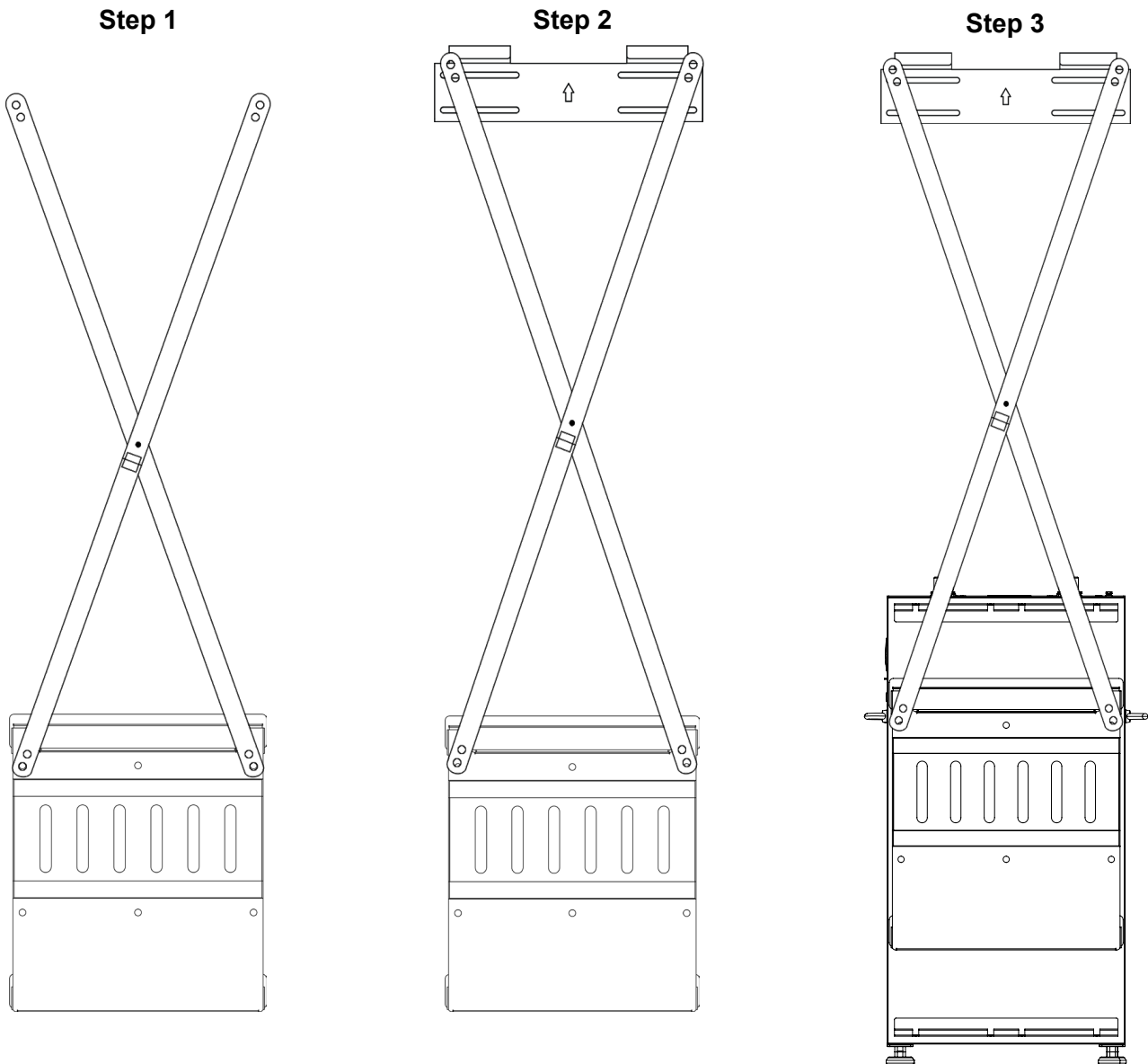

Images for representative purposes only.

Step 4

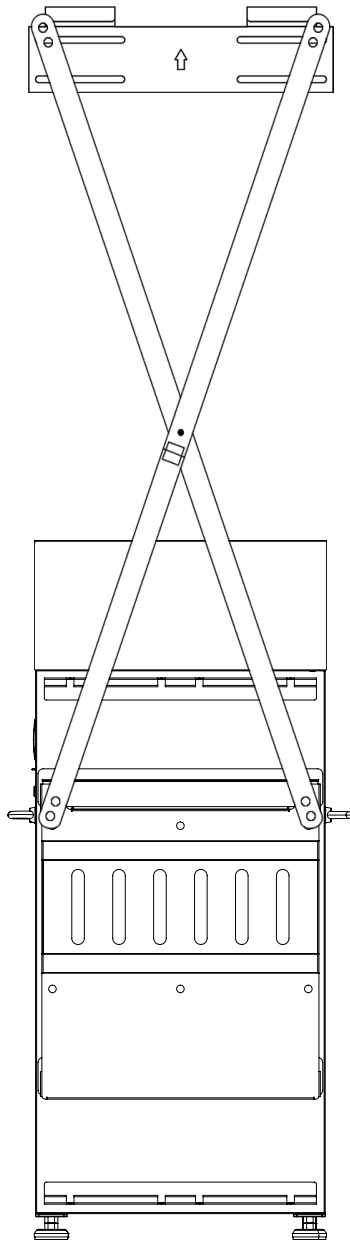

Step 5

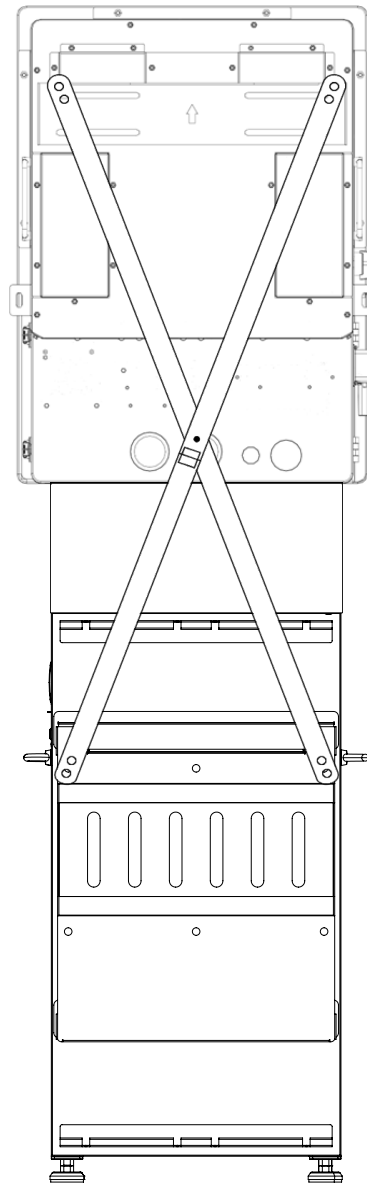

7. CONNECTING MULTIPLE BATTERIES IN PARALLEL

When paralleling multiple EG4® WallMount 314Ah Indoor batteries, a paralleling kit is required and recommended to be purchased through the distributor. When paralleling batteries, utilize the battery-to-battery communications cable included in the paralleling kit to parallel each battery together.



IMPORTANT:

The battery can charge up to 157A and discharge up to 200A before the BMS shuts off the battery. Confirm the inverter is properly configured to maintain the respective charge/discharge rates of the battery. If needing to create custom battery power cables, see an NEC approved ampacity chart.

7.1 BMS COMMUNICATION WIRING

The following diagram shows the battery communication cable wiring when using strictly Auto-ID BMS Protocol.

Follow the guidelines listed below:

1. Starting from the last battery in the stack, use the included communication cables to parallel the batteries together. Plug the cable into the Comm 1 port on the last battery, and daisy chain up to Comm 2 port on the next battery and repeat until the master battery is reached.
2. Depending on whether the system uses CAN or RS485 communications, plug the battery to inverter communication cable in either the CAN or RS485 port on the master battery and then connect the cable to the respective battery communication port on the inverter.
3. Use the included 120Ω terminating resistor to “close” the communication loop by plugging in to the “Comm 1” port on the master battery.
4. Use a second 120Ω terminating resistor to “close” the communication loop by plugging in to the “Comm 2” port on the last battery in the stack.



NOTE:

When using closed-loop communication, connect the 120Ω terminating resistor to the Comm 1 port on the master battery. Verify the resistor is connected to the correct port. Connecting to the wrong port may cause damage to the system and attached components.

For additional examples of paralleling batteries, see the next page for more example diagrams.

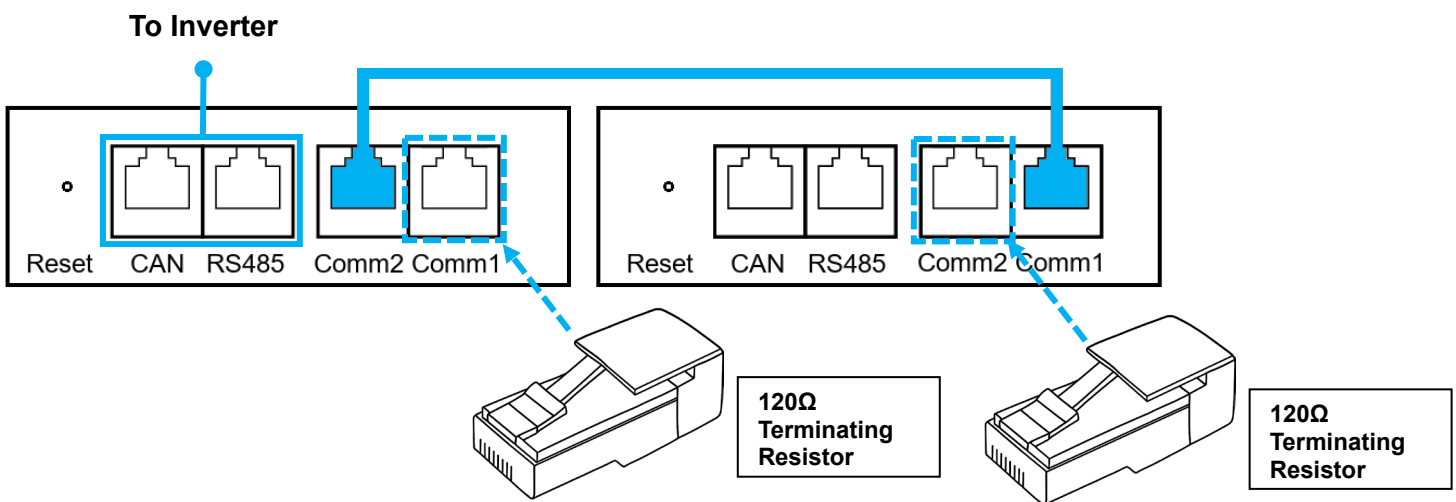

WARNING:

Do not put EG4® batteries in series! The BMS and internal components are not designed to handle this setup which could cause the modules to fail, leading to damage.



NOTE:

The master battery will communicate directly with the system via the CAN/RS485 port.

WallMounts in Parallel x 3

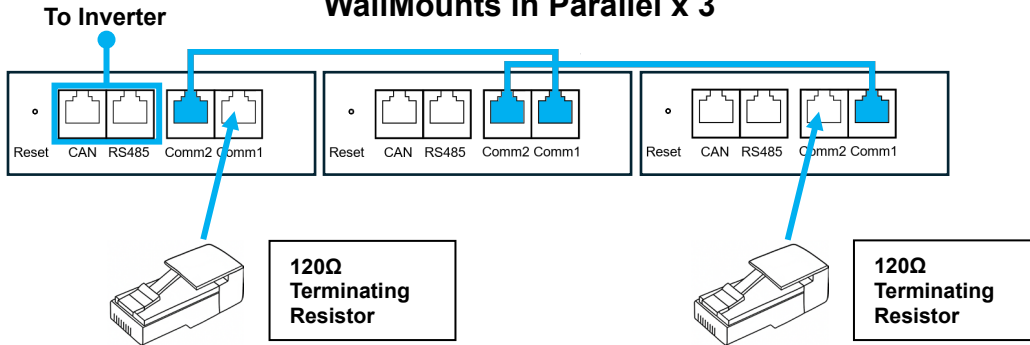

WallMounts in Parallel x 4

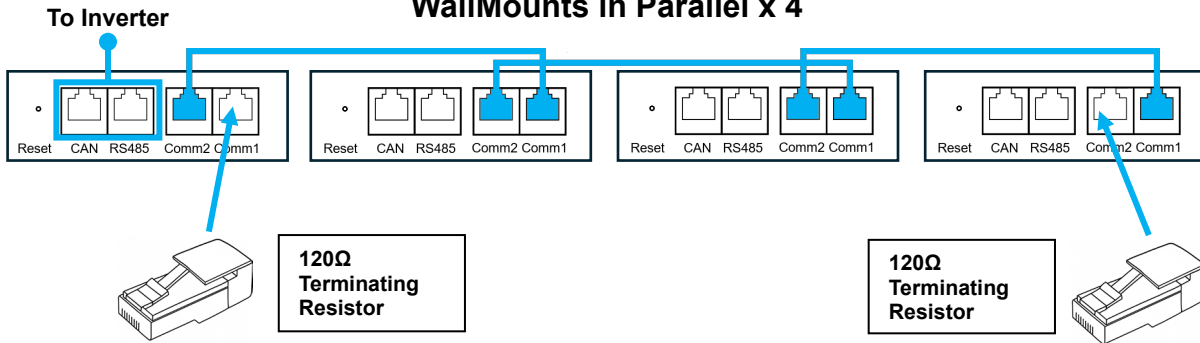

WallMounts in Parallel x 5

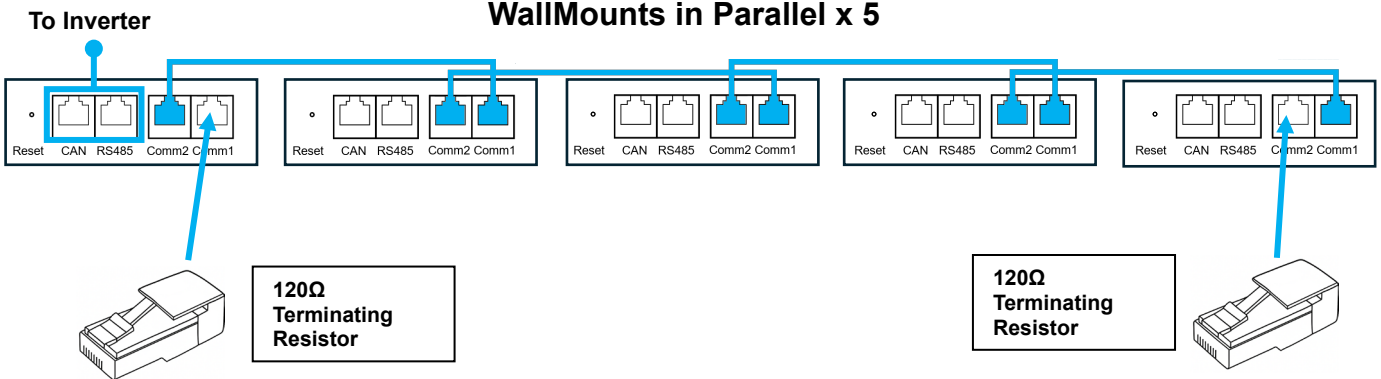

WallMounts in Parallel x 6

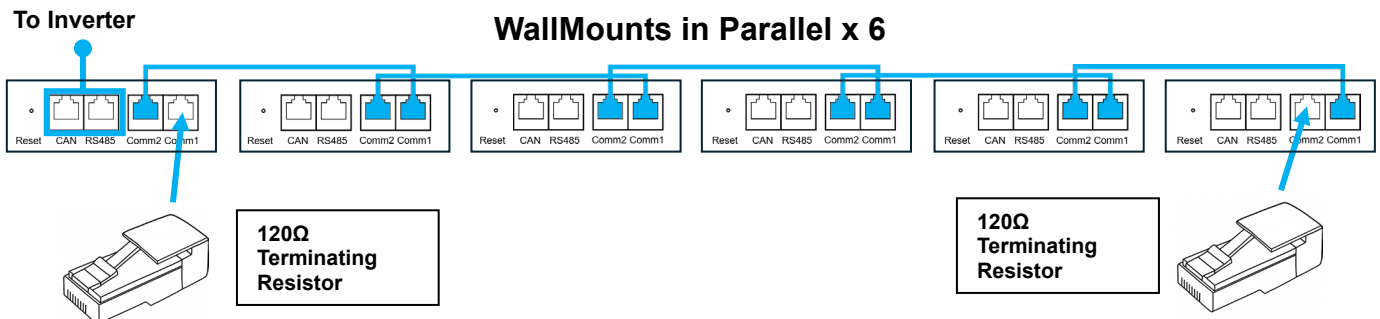

7.2 BATTERY CABLE CONNECTIONS

The following battery cable connection diagrams are examples using the internal busbars to parallel the batteries together and attach the inverter(s) to the batteries. When relying on internal busbars, up to 6 batteries are supported in parallel, whether connected to one, two, or three EG4® FlexBOSS21 inverters.

Systems requiring more than 6 batteries in parallel must use an external fused positive busbar and an unfused negative busbar rated at a minimum of 200A per battery. Each fuse should be a maximum of 250A. Alternatively, larger systems may utilize the FlexBOSS21's ability to draw from separate battery packs while still paralleling inverters, rather than relying solely on common external busbars.



NOTE:

In the following diagrams, the inverter communications cable is connected to the CAN/RS485 port on the FlexBOSS21 inverter and units are spaced 4 in. (101.6 mm) apart. Local regulations may require a larger minimum battery spacing. Check with the local AHJ for these requirements. If longer parallel cables than those included in the optional paralleling kit are required, please check with the distributor for availability.

Illustrations for representative purposes only.

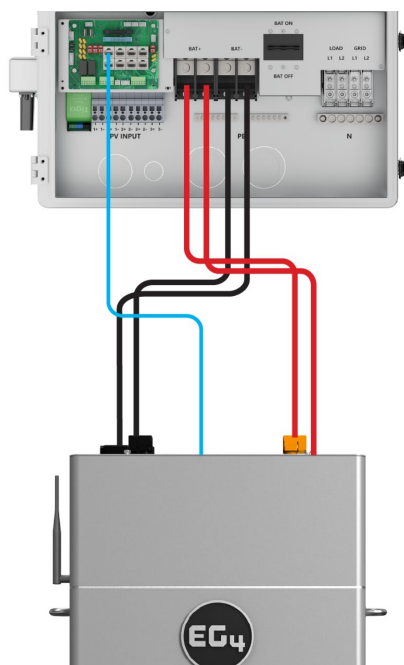

(1) FlexBOSS21 with (1) 314 Indoor



Note: To comply with the UL9540 listing for this integrated battery, conduit box, and inverter system, the batteries must be wired as shown on page 34 – 38 using the supplied inverter to battery cables. *An additional paralleling kit is required for each additional paralleled battery (sold separately).*



Caution: To minimize voltage drop in the wire, the battery cables should maintain optimum length. The 53.1 in. cables from the “parallel kit” are sufficient to daisy chain the batteries.

Color Code

- – Communication Cable
- – Positive Cable
- – Negative Cable



CAUTION:

When pairing the EG4® WallMount 314Ah Indoor battery with an inverter, do not exceed >600A load on the master battery due to the internal busbar rating.

ADDITIONAL SINGLE INVERTER CONFIGURATIONS

Illustrations for representative purposes only.

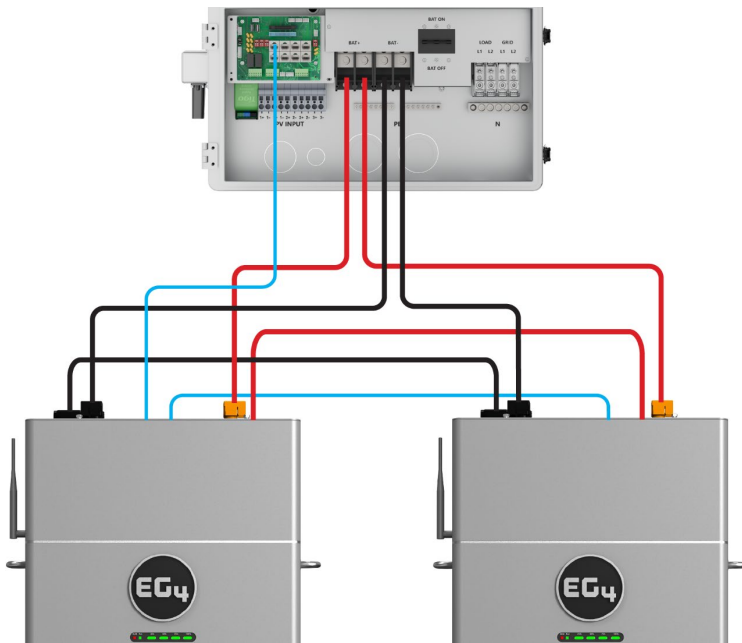

(1) FlexBOSS21 with (2) 314 Indoor



Note: Some configurations require additional wiring/connectors to achieve the example layouts. Inverter to inverter paralleling cables are not shown in the following diagram.

Other configurations can be achieved by using external busbars. Contact an electrician or qualified personnel for optional system layout.



Reminder!

The separation between batteries should be ≥ 4 in.

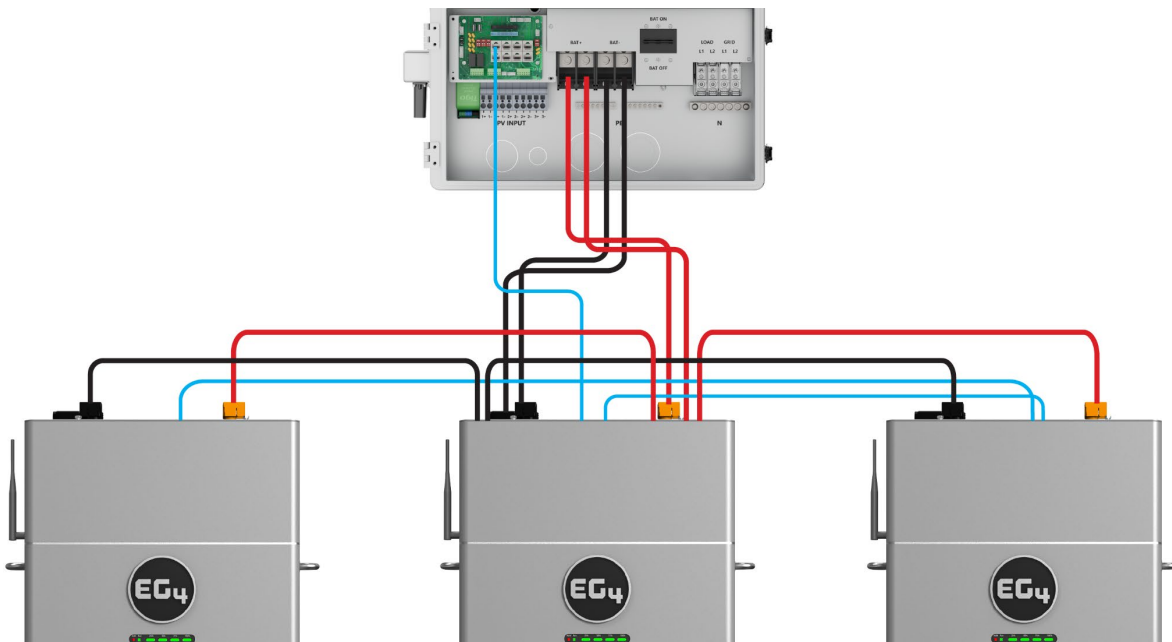

(1) FlexBOSS21 with (3) 314 Indoor

TWO INVERTER CONFIGURATIONS

Illustrations for representative purposes only.

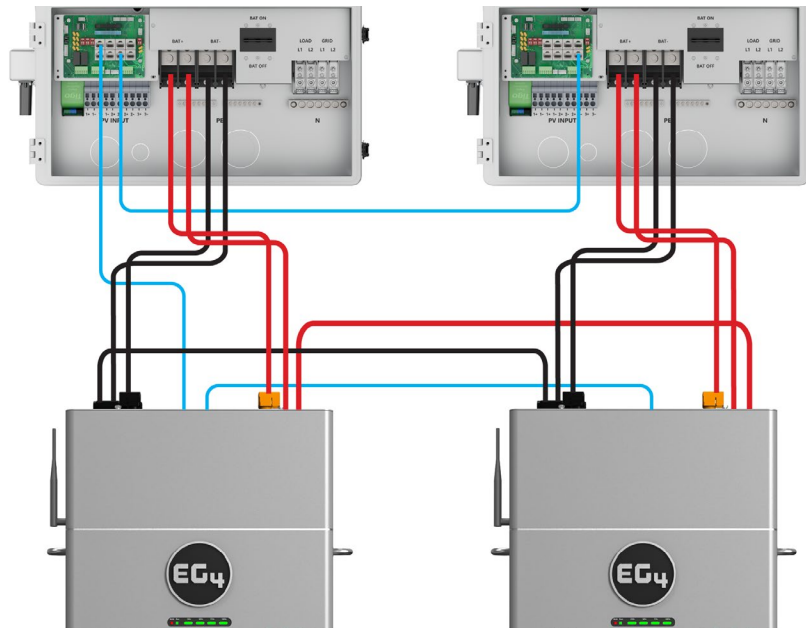

(2) FlexBOSS21 with (2) 314 Indoor

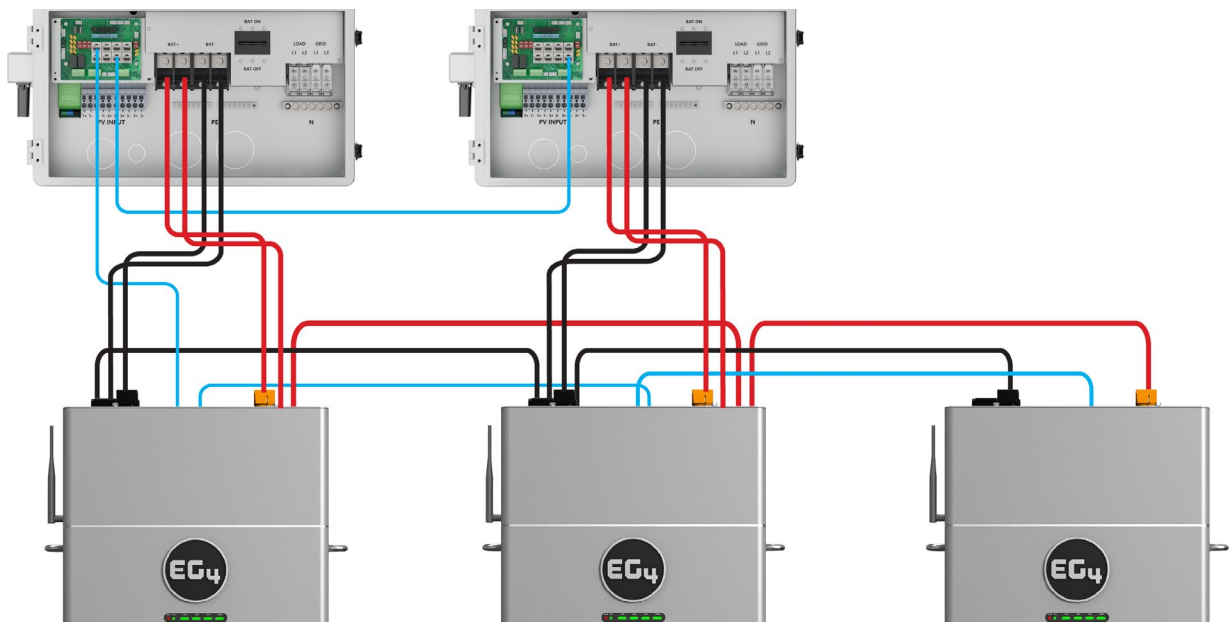

(2) FlexBOSS21 with (3) 314 Indoor

Illustrations for representative purposes only.

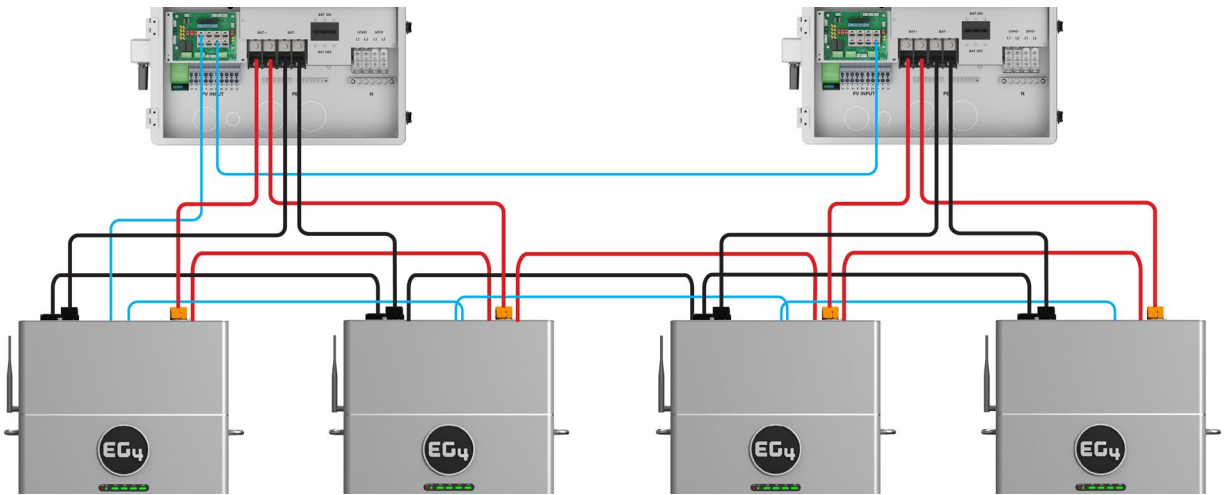

(2) FlexBOSS21 with (4) 314 Indoor

THREE INVERTER CONFIGURATIONS

Illustrations for representative purposes only.

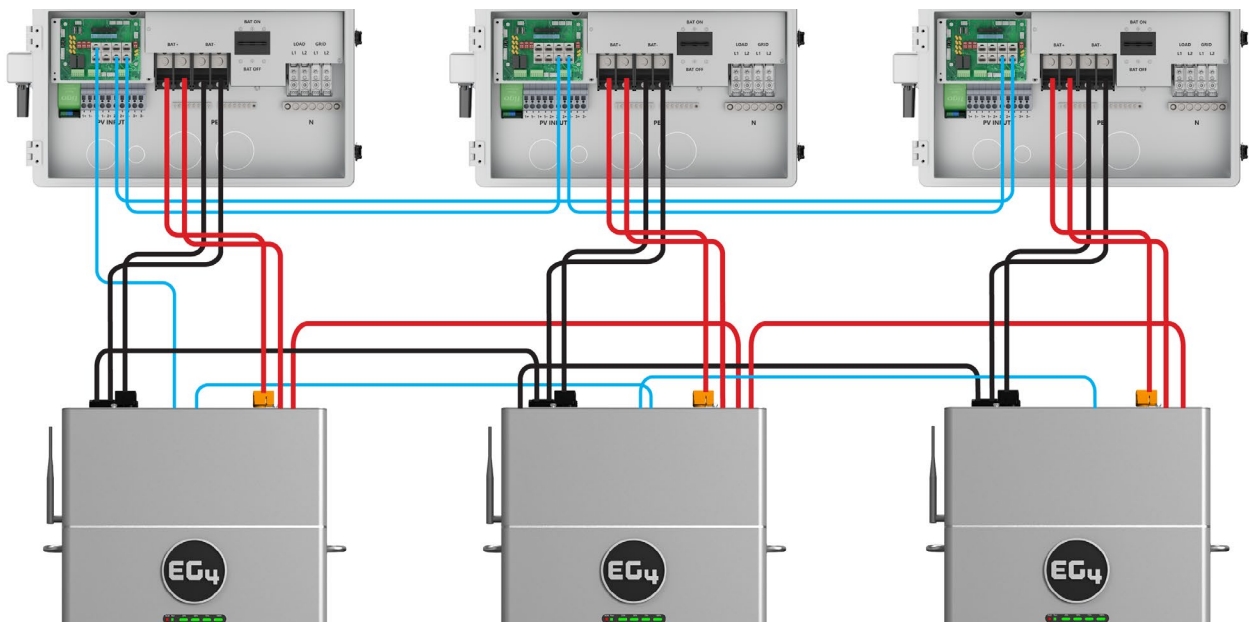

(3) FlexBOSS21 with (3) 314 Indoor

Illustrations for representative purposes only.

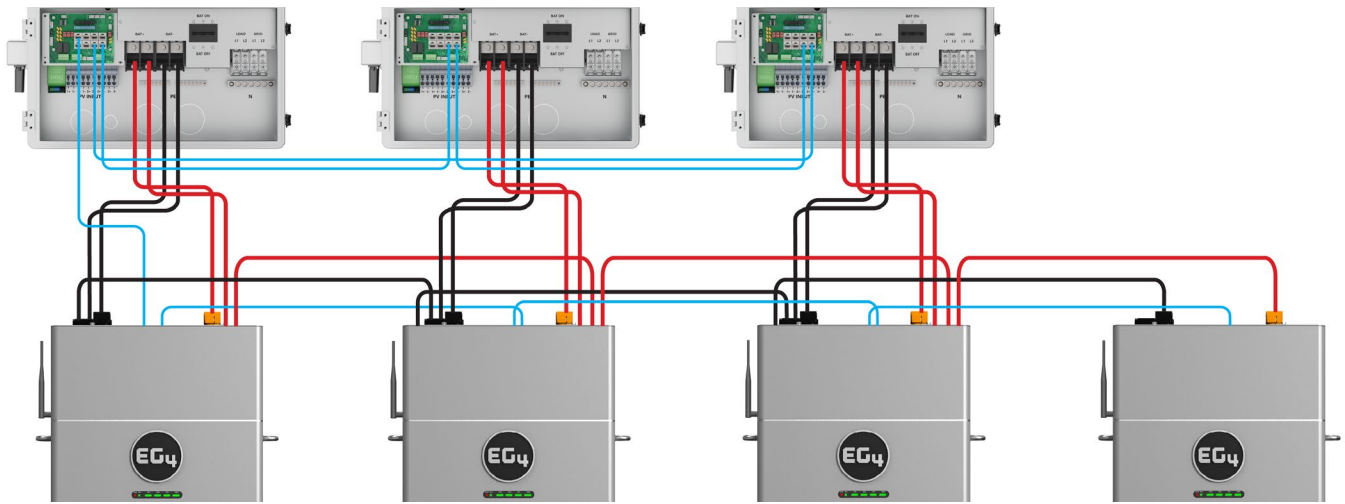

(3) FlexBOSS21 with (4) 314 Indoor

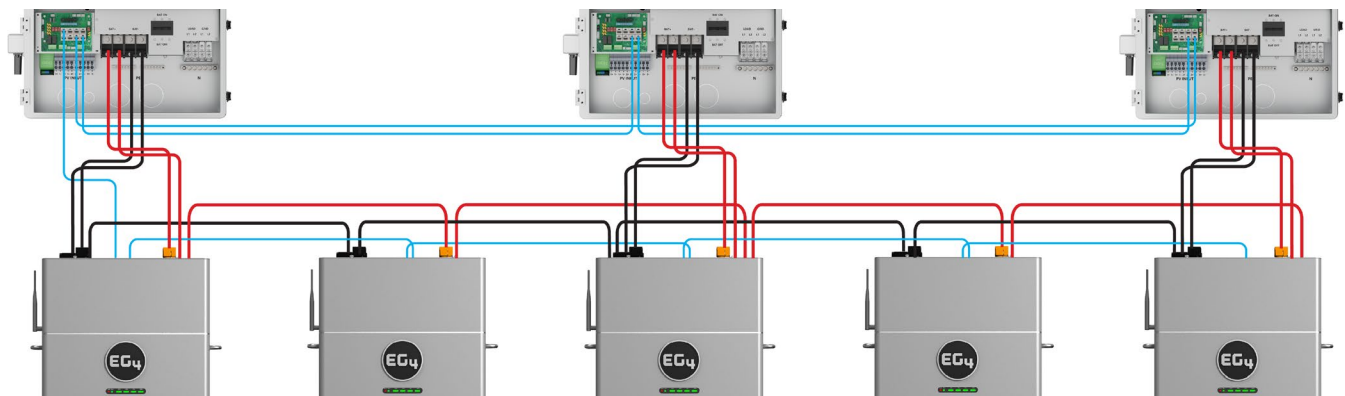

(3) FlexBOSS21 with (5) 314 Indoor

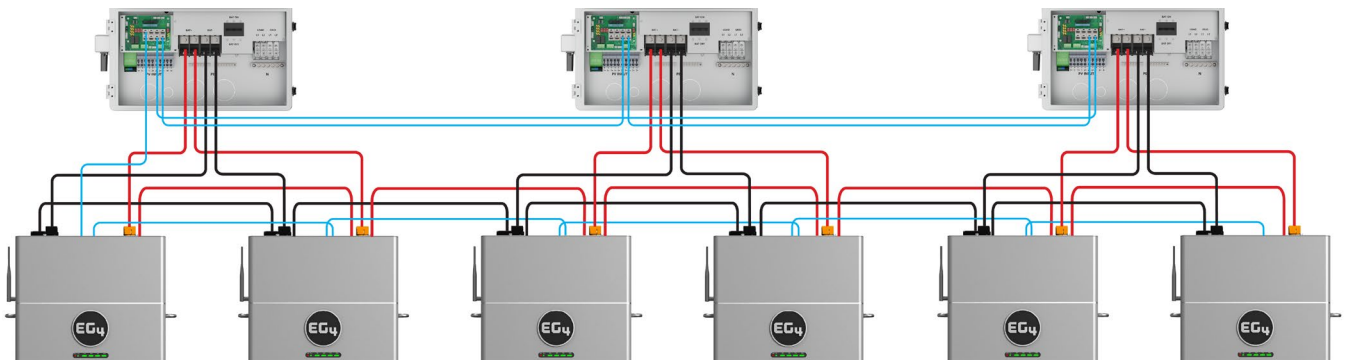

(3) FlexBOSS21 with (6) 314 Indoor

8. BATTERY COMMUNICATIONS

Each EG4® battery is engineered with seamless communication between the battery and inverter, ensuring the end user can easily monitor and control their system. The battery features advanced communication protocols that allow real-time data exchange with the inverter, providing crucial insights into battery performance, charge levels, and system status.

8.1 AUTO-ID BMS PROTOCOL FEATURE

The EG4® WallMount 314Ah Indoor Battery is designed to eliminate the need for manual dipswitch configuration and protocol selection; Auto-ID automatically detects the correct inverter communication protocol and assigns unique battery IDs for seamless multi-battery communication.

At its core, Auto-ID manages two key functions: protocol detection and ID assignment. When the master battery is powered on and connected, the BMS checks for inverter communication signals and automatically selects the proper protocol. For example, when paired with the EG4 FlexBOSS21 inverter, the BMS would set to the EG4/Lux protocol without requiring any user configuration.

At the same time, the system assigns the first battery as ID:1 (master). Additional Auto-ID batteries added to the chain automatically receive unique IDs in the proper sequence. This means that installers no longer need to set the master unit manually or configure each subsequent battery; the process is handled internally by the BMS. Auto-ID BMS Protocol is only available on EG4 batteries that have no DIP switches. Scan the QR code below for more information regarding Auto-ID BMS Protocol features.



8.2 BMS AUTO-ID PROCEDURE



NOTE:

The 120Ω terminating resistor is used for establishing battery to battery closed-loop communication. The inverters listed in section 8.3 are capable of closed-loop communication with the battery.

1. Ensure all battery breakers in the parallel battery bank are in the OFF position.
2. Verify all physical connections have been placed securely and correctly according to the wiring diagrams for communication found in section 7.1.
3. Install a 120Ω terminating resistor in Comm1 of the master battery and in Comm2 of the last battery in the parallel battery bank.
4. Press the BMS On/Off button to turn on the BMS on the master battery. The Auto-ID process will begin and takes about 3 – 5 seconds as the master battery assigns IDs to the slave batteries.
5. Power on each remaining battery one at a time in ~5 second intervals by pressing the BMS On/Off button, starting with the battery directly after the master and continuing down the line.
6. The batteries should have successfully been assigned ID's automatically. Confirm with all batteries and inverters that no faults or protections have been triggered after powering on the batteries.

8.3 COMMUNICATION CABLE PINOUT

EG4® batteries interface with an inverter by designating a “Master” battery (ID No. 1). The Auto-ID feature will automatically designate the first battery plugged into the CAN port as the master battery with ID No. 1. The available ID codes range from 1 – 32. The battery will connect directly to the inverter via a CAT 5, 5e, or 6 cable pinned 1-5 on the inverter side. For closed loop communications using CAN bus protocols with non-EG4 inverters, please check the inverter manufacturer’s documentation for more information.

Communication Cable Pinout & Table*

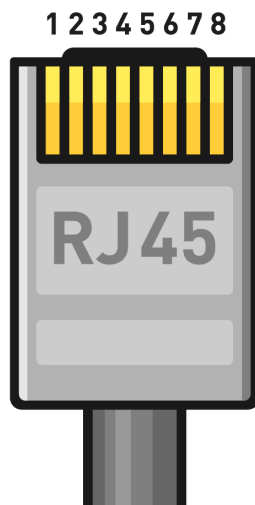

PIN	DESCRIPTION
1	RS485-B
2	RS485-A
3	CAN Ground (optional)
4	CAN High
5	CAN Low

***Pinouts are for battery side; please refer to the inverter user manual for pinout configuration on system end.**

RS485 COMMUNICATION COMPATIBLE INVERTERS:

- EG4
- Growatt
- Schneider
- Voltronic

CAN COMMUNICATION COMPATIBLE INVERTERS:

- EG4
- Growatt
- Deye
- Megarevo
- Luxpower
- Victron
- Solis
- SMA

9. BATTERY STARTUP AND SHUTDOWN PROCEDURE

The battery comes with pre-charged resistors which promote a specific sequence of events to provide power to the inverter. Pre-charged resistors are essential in 51.2V nominal voltage systems to help reduce the in-rush current the inverter will request from the batteries upon startup.

9.1 STARTUP

After all physical connections are made and the inverter is ready to accept battery power, follow the steps listed below:

1. Close (turn on) the battery's circuit breaker.
2. Wait ~5 seconds, then turn on the battery's BMS by pressing the power button on the side of the unit.



NOTE:

When using multiple batteries in parallel, repeat the steps listed above per battery, always starting with the master battery.

9.2 SHUTDOWN

1. Power off the battery's BMS by pressing the power button on the side of the unit.
2. Open (turn off) the battery's circuit breaker.



NOTE:

When using multiple batteries in parallel, repeat the steps listed above per battery, always starting with the master battery.



10. TROUBLESHOOTING, MAINTENANCE & DISPOSAL

ALARM DESCRIPTION AND TROUBLESHOOTING

When the ALM light on the battery control panel is on, it means that the battery has given an alarm or has been protected from potential damage. Check the cause of the alarm or fault through the app or BMS Tools and take appropriate measures or go directly to the battery site to troubleshoot.

Battery LED alarms are shown in the tables below:

10.1 LED INDICATOR STATUS AND DEFINITION

STATUS	NORMAL/ ALARM/ PROTECTION	RUN	ALM	SOC INDICATOR LED	NOTES
				SOC1~SOC4	-
Shutdown/Sleep		OFF	OFF	OFF	-
Stand-by	Normal	ON	OFF	Based on battery indicator (Each LED indicates 25% SOC)	-
Charge	Normal	Flash 1	OFF		-
	Alarm	Flash 1	Flash 1		-
	End-off Voltage	ON	OFF		-
	Over-Temp Protection	OFF	ON		-
	Over-current transfer limit current	Flash 1	Flash 3/OFF		Over-current flash 3, limit-current OFF
Discharge	Normal	Flash 2	OFF	Based on SOC indicator	-
	Alarm	Flash 2	Flash 3		-
	End-off Voltage	OFF	OFF		Go to sleep
	Over-Temp/ Over-current Protection	OFF	ON		-

The following bullets further define the values in the table above:

- **SOC:** Every light represents ~25% capacity
- **Shutdown:** All LED lights are off
- **Power on:** RUN light is always on
- **System failure:** ALM light is always on
- **Flash 1:** Flash once every second
- **Flash 2:** Flash once every 1.5 seconds
- **Flash 3:** Flash once every 2 seconds

WARNING DEFINITIONS AND SOLUTIONS

STATE	TYPE	INDICATOR	SOLUTION
Charge	Over current protection	ALM	Stop charge, check the settings and limitation
	Temperature protection	ALM	Stop charge, wait for the temp to recover
Discharge	Over current protection	ALM	Stop discharge, check if there is an overload
	Temperature protection	ALM	Stop discharge, wait for the temp to recover



WARNING:

The “Historical Record” tab can indicate what occurred with the module before entering a warning or protection state. It is recommended to export this data into a text (.txt) file to provide the distributor with additional troubleshooting assistance.

If any warnings or faults from both tables persist, contact the distributor for additional troubleshooting steps.

FAULT DEFINITIONS AND SOLUTIONS

NO.	FAULT	ANALYSIS	SOLUTION
1	Inverter communication failure	Check communication port connection, and battery ID setting.	Check communication wiring and restart BMS. See section 7.1 for wiring information.
2	No DC output	Open breaker, or battery voltage is too low.	Close the battery breaker or charge the battery.
3	Power supply unstable	Battery capacity is not at full power.	Check for proper battery cable connection.
4	Battery cannot be fully charged	DC output voltage is below the minimum charge voltage.	Check charging settings on the inverter to ensure they match battery requirements.
5	ALM LED always on	Short circuit	Disconnect the power cable and check all cables.
6	Battery output voltage is unstable	Battery management system is not operating normally.	Press the reset button to reset the battery, then reboot the system.
7	ALM LED flashes 20 times with SOC1 LED on	Unbalanced voltage within a cell.	Deep discharge the battery bank (<20% SOC), then fully charge the battery bank.
8	ALM LED flashes 20 times with SOC2 LED on	Unbalanced temperature.	Double check the temperature of the battery. If the temperature range is good, restart the battery. If the issue persists, contact the distributor.
9	ALM LED flashes 20 times with SOC3/SOC4 LED on	Battery management system is damaged.	Contact the distributor.
10	Different SOC value of batteries in parallel operation	No issue.	Deep discharge the battery bank (<20% SOC), then fully charge the battery bank.
11	Low voltage protection with no LED on	BMS is in low voltage protection and is in sleep mode.	Fully charge and restart the battery. If issue persists, contact the distributor.
12	Deep discharged with no LED on	Battery voltage is too low to start the BMS	Apply low charge to the battery until BMS is able to start up. If the issue persists, contact the distributor.

10.2 MAINTENANCE

ITEM	MAINTENANCE INTERVAL	MAINTENANCE SOLUTION
Power Cables	Every 6 months	<ol style="list-style-type: none"> 1. Inspect the power cable for any signs of mechanical damage and ensure that the terminal insulation sleeves are intact. If any damage is found, turn off the battery and perform maintenance or replace the cable. 2. Check for any looseness in the power cable. If there are any signs of looseness, replace the cable. 3. Examine the system for loose screws. If any screws are found loose, tighten them with the proper hardware.
Communication Cables	Every 12 months	<ol style="list-style-type: none"> 1. Verify that the terminals of the parallel communication cable are securely tightened. If any terminal is loose, retighten it. 2. Check the communication cable for any obvious discoloration. If discoloration is present, shut down the battery and replace the communication cable. See section 7 for more information.
System Status	Every 6 months	<ol style="list-style-type: none"> 1. Check that all parameters (system voltage, current, temperature, etc.) are normal when the system is running. 2. Check that the main core components of the system, including system switches and contactors, are functioning properly.
Charge & Discharge	Every 6 months	Perform a light load and shallow charge/discharge test to access the normality of the SOC and SOH status of the battery (using the EG4 monitor site to read the parameters). It is recommended that the depth of discharge and charge/discharge power should not exceed 20% of the rated value.

10.3 BATTERY END OF LIFE

The EG4® WallMount 314Ah Indoor Battery is designed to last for **more than 15 years** when used correctly, assuming no more than one charge-discharge cycle per day. We have worked tirelessly to ensure that our batteries will maintain a charge after thousands of cycles. However, when it comes to time to retire the battery, there are a few things to consider.

Lithium iron phosphate batteries are considered a hazardous material and should not be disposed of by simply placing them in the trash. There are several websites and organizations that will accept this battery to recycle at little to no cost to the user. At EG4, we understand that we are working with customers across the United States and the world. Our recommendation is to go online and search the term “Lithium Battery Disposal Near Me.” There will likely be an assortment of organizations that can safely dispose of LFP batteries.

We recommend calling ahead of time to ensure that the location is still open and accepting material.

If users are unable to locate a disposal location safely, EG4 is here to help. Before dumping the battery or disposing of it incorrectly, please contact our customer service team for assistance.

11. WARRANTY INFORMATION

For information regarding warranty registration on EG4® Electronics products, please navigate to <https://eg4electronics.com/warranty/> and select the corresponding product to begin the registration process.

12. CHANGELOG

V1.0.4

- Updated location requirements to include installations not intended near marine environments
- Changed UL9540A from pending to yes
- Modified spec sheet certifications and compliance section
- Updated safety sections
- Updated Intertek/ETL Test Report number in section 6.2

V1.0.3

- Added additional battery model number
- Added Battery Heater specifications to spec sheet
- Updated Max Parallel Units from 16 to 32
- Updated lifetime production value
- Updated verbiage throughout for readability
- Updated section 6 headings to properly reflect the sections

V1.0.2

- Modified verbiage for better readability
- Updated section 5.7 for clarity
- Added “Symbols Used in Manual” and “Symbols Used on Equipment” in section 3.2
- Updated images in section 8.1 to better reflect product

V1.0.1

- Added link to supported UL9540 configurations

V1.0

- Published quick start guide

EG4

ELECTRONICS

support@eg4electronics.com
(903) 609-1988
www.eg4electronics.com