

# EG4<sup>®</sup> WALLMOUNT 314Ah ALL WEATHER BATTERY

---

## QUICK START GUIDE



**TABLE OF CONTENTS**

1.	TECHNICAL SPECIFICATIONS.....	1
2.	ABBREVIATIONS .....	3
3.	BATTERY SAFETY .....	4
3.1	SAFETY INSTRUCTIONS.....	4
3.2	IMPORTANT SAFETY NOTIFICATIONS.....	4
4.	SÉCURITÉ DE LA BATTERIE.....	8
4.1	CONSIGNES DE SÉCURITÉ.....	8
4.2	NOTIFICATIONS DE SÉCURITÉ IMPORTANTES.....	8
5.	PRODUCT OVERVIEW .....	14
5.1	BATTERY DIMENSIONS .....	15
5.2	PACKING LIST .....	16
5.3	BMS OVERVIEW .....	16
5.4	STORAGE INFORMATION .....	17
5.5	BATTERY PERFORMANCE CURVES .....	18
5.6	BATTERY CHARGING.....	19
5.7	FRONT PANEL INDICATOR LIGHTS.....	19
6.	GENERAL INSTALLATION.....	20
6.1	RECOMMENDED TOOLS .....	20
6.2	LOCATION REQUIREMENTS .....	21
6.3	BATTERY INSTALLATION.....	22
6.4	BATTERY WITH CONDUIT BOX .....	26
6.5	BATTERY, CONDUIT BOX, & 18KPV .....	28
6.6	BATTERY, CONDUIT BOX, & 12KPV/FLEXBOSS18/21.....	30
7.	CONNECTING MULTIPLE BATTERIES IN PARALLEL .....	32
7.1	BMS COMMUNICATION WIRING .....	32
7.2	BATTERY CABLE CONNECTIONS .....	32
8.	BATTERY COMMUNICATIONS.....	39
8.1	AUTO-ID BMS PROTOCOL FEATURE .....	39
8.2	BMS AUTO-ID PROCEDURE.....	40
8.3	COMMUNICATION CABLE PINOUT.....	40
9.	BATTERY STARTUP AND SHUTDOWN PROCEDURE.....	42
9.1	STARTUP .....	42
9.2	SHUTDOWN .....	42
10.	TROUBLESHOOTING, MAINTENANCE & DISPOSAL.....	43
10.1	LED INDICATOR STATUS AND DEFINITION.....	43
10.2	MAINTENANCE.....	45
10.3	BATTERY END OF LIFE.....	46
11.	WARRANTY INFORMATION .....	47
12.	CHANGELOG .....	48

# 1. TECHNICAL SPECIFICATIONS

TYPE & MODEL #		
PARAMETER	SPECIFICATION	
PRODUCT TYPE	LFP Battery	
BATTERY TYPE	Lithium Iron Phosphate (LiFePO4)	
MODEL NUMBER	WM48314AWXX (XX is a number between 00 – 99)	
ELECTRICAL CHARACTERISTICS		
NOMINAL ENERGY CAPACITY	16kWh	
RECOMMENDED USABLE ENERGY (DOD%)	12.86kWh (80% recommended)	
RECOMMENDED VOLTAGE RANGE	47.5 – 56 VDC	
NOMINAL VOLTAGE	51.2 VDC	
CAPACITY	314Ah	
CHARGING VOLTAGE RANGE	56 – 57 VDC	
DISCHARGING CUT-OFF VOLTAGE	44.8 VDC	
MAX CONTINUOUS/RECOMMENDED CHARGE CURRENT	157A/157A	
MAX CONTINUOUS/RECOMMENDED DISCHARGE CURRENT	200A/157A	
CONTINUOUS CHARGE/DISCHARGE POWER	8/10.2 kW	
RECOMMENDED CHARGING/DISCHARGING RATE	0.5C	
SHORT CIRCUIT CURRENT	1700A, 15ms delay	
PEAK POWER	12.8kW (3 sec)	
ROUND-TRIP EFFICIENCY	95%	
MAX PARALLEL UNITS	32	
PROTECTION FEATURES	Over/Under Voltage, Over-Current, Short Circuit, High/Low Temp	
BATTERY MANAGEMENT SYSTEM [BMS]	Integrated, Active Balancing	
COMMUNICATION PROTOCOLS	RS485, CAN	
BATTERY BREAKER	250A	
BATTERY HEATER SPECIFICATIONS		
PARAMETER	SPEC	CONDITION
VOLTAGE	56V	-
POWER CONSUMPTION	448W	-
INTERNAL BATTERY TEMPERATURE	≤32°F (0°C)/≥37°F (3°C)	Heat On/Heat Off
ENVIRONMENTAL SPECIFICATIONS		
STORAGE TEMPERATURE RANGE*	-4 – 131°F (-20 – 55°C)	
HUMIDITY RANGE	5% – 95% RH (non-condensing)	
ALTITUDE	9843 ft. (<3000 m)	
COOLING METHOD	Natural Convection	
DIMENSIONS [H × W × D]	34.6 in. × 21.7 in. × 9.3 in. (880 mm × 550 mm × 235 mm)	
OPERATING TEMPERATURE RANGE	Charge: 32 – 122°F (0 – 50°C) Discharging: -4 – 131°F (-20 – 55°C)	

\*Less than 3 months of storage. If longer than 3 months, recommended storage temperature will be 59°F – 86°F (15°C - 30°C). Refer to section 5.4 for complete storage requirements.

## MECHANICAL SPECIFICATIONS

PARAMETER	SPECIFICATION
WEIGHT	309 lbs. (140 kg)
ENCLOSURE RATING	IP67
MOUNTING OPTIONS	Floor mount/wall attached
DISPLAY/INDICATORS	LED Status
CONNECTOR TYPE	Degson quick connector/screw terminal

## CERTIFICATIONS & COMPLIANCE

UL 1973	Yes
UL 9540	See <a href="https://eg4electronics.com/">https://eg4electronics.com/</a> for supported UL 9540 configurations
UL 9540A	Yes

## WARRANTY & LIFECYCLE

CYCLE LIFE [70% EOL CAPACITY]*	10000 cycles @ 0.5C, 25°C, 80% DOD
DESIGN LIFE	10 years
WARRANTY	10 years or 10000 cycles
LIFETIME PRODUCTION**	122.2 MWh
APPLICATION TYPE	Residential/Commercial/Off-grid/Backup

\*EG4 recommends this value be set no lower than 20% to maintain the recommended 80% Depth of Discharge.

\*\* $(51.2V \times 314Ah / 1000 \times 80\% \times 10000 / 1000) \times 95\% = 122.2 \text{ MWh}$  or  
 $(12861 \text{ kWh} \times 10000 \text{ cycles} \times 95\% \text{ efficiency}) = 122.2 \text{ MWh}$

## **2. ABBREVIATIONS**

- AWG – American Wire Gauge
- A – Amps
- Ah – Amp hour(s)
- AC – Alternating Current
- AFCI – Arc-Fault Circuit Interrupter
- AHJ – Authority Having Jurisdiction
- kAIC – kilo-Amp Interrupting Capability
- ANSI – American National Standards Institute
- BAT – Battery
- BMS – Battery Management System
- COM – Communication
- CT – Current Transformer
- DC – Direct Current
- DIP – Dual In-line Package
- DOD – Depth of Discharge
- EG – Equipment Ground
- EGS – Equipment Grounding System
- EMC – Electromagnetic Compatibility
- EPS – Emergency Power System
- ESS – Energy Storage System
- E-Stop – Emergency Stop
- FCC – Federal Communication Commission
- GE – Grounding Electrode
- GEC – Grounding Electrode Conductor
- GFCI – Ground Fault Circuit Interrupter
- GFDI – Ground Fault Detector/Interrupter
- Imp – Maximum Power Point Current
- IEEE – Institute of Electrical and Electronic Engineers
- IP – Ingress Protection
- I<sub>sc</sub> – Short-Circuit Current
- In-lbs. – Inch Pounds
- kW – Kilowatt
- kWh – Kilowatt-hour
- LCD – Liquid Crystal Display
- LFP – Lithium Iron Phosphate
- L1 – Line 1
- L2 – Line 2
- mm – Millimeters
- MPPT – Maximum Power Point Tracking
- mV – Millivolt
- N – Neutral
- NEC – National Electric Code
- NEMA – National Electrical Manufacturers Association
- NFPA – National Fire Protection Association
- Nm – Newton Meters
- NOCT – Normal Operating Cell Temperature
- PC – Personal Computer
- PCB – Printed Circuit Board
- PE – Protective Earth
- PPE – Personal Protective Equipment
- PV – Photovoltaic
- RSD – Rapid Shut Down
- SCC – Standards Council of Canada
- SOC – State of Charge
- STC – Standard Testing Conditions
- UL – Underwriters Laboratories
- UPS – Uninterrupted Power Supply
- V – Volts
- VOC – Open-Circuit Voltage
- VMP – Voltage Maximum Power

## 3. BATTERY SAFETY

### 3.1 SAFETY INSTRUCTIONS

Before starting any work, read all safety instructions carefully and follow them at all times when working on or near the battery. Qualified service personnel must install the system in strict accordance with the installation instructions, using proper installation practices and complying with all applicable local electrical, building, fire, and utility codes and regulations. Consult the local Authority Having Jurisdiction (AHJ) to obtain the required permits and approvals before installation.

**Incorrect installation may cause:**

- Injury or death to the installer, operator, or third party
- Damage to the battery or other attached equipment

### 3.2 IMPORTANT SAFETY NOTIFICATIONS



#### **DANGER: Hazardous Voltage Circuits!**

#### **AVERTISSEMENT! Circuits à tension élevée!**

Observe all safety requirements carefully before, during, and after installation, as well as throughout future operation and maintenance. The following safety notifications apply to installers and end users and must be followed under normal operating conditions.

1. **Do not disassemble the battery.** Contact the distributor for repair-related issues, additional information, and proper handling instructions. Improper servicing or reassembly may create a risk of electric shock or fire and may void the warranty.
2. **The ESS uses DC current.** DC current can cause continuous muscle contraction during an electric shock and may result in severe burns or fire if the product is mishandled.
3. Damage to the ESS or improper installation may cause arc flashing, resulting in serious damage, injury, or death.
4. **Beware of high battery current.** Verify that the battery module breakers and/or on/off switches are in the “Open” or “Off” position before installing or servicing the battery. Use a voltmeter to verify that no voltage is present to prevent electric shock.
5. **Do not connect or disconnect any system components while the batteries are operating.** Working with energized batteries may damage system components and create a risk of electric shock.
6. Confirm that the batteries are properly grounded.
7. Installers must protect themselves with appropriate professional insulating equipment, such as personal protective equipment (PPE).
8. Before installing, operating, or maintaining the system, inspect all existing wiring to confirm it meets the required specifications and is in suitable condition for use.
9. Verify that all battery and system component connections are secure and properly installed to prevent damage or injury.
10. Battery rupture or shorted battery cells can release toxic gases and harmful electrolyte solutions.



## **WARNING: TO REDUCE THE RISK OF INJURY, READ ALL INSTRUCTIONS!**

All work on this product (system design, installation, operation, setting, configuration, and maintenance) must be carried out by qualified personnel. To reduce the risk of electric shock, do not perform any servicing other than that specified in the operating instructions unless qualified to do so.

11. Read all instructions before beginning installation. Perform all electrical work in accordance with these installation instructions and all applicable local and national wiring standards and regulations. Install all wiring in compliance with the National Electrical Code (NEC), ANSI/NFPA 70.
12. Connect the battery and system to the utility grid only with approval from the utility provider. Before installation, consult the local Authority Having Jurisdiction (AHJ) to confirm any additional regional regulations or requirements.
13. Keep all warning labels and nameplates on the battery clearly visible at all times, and do not remove or cover them.
14. When selecting the battery's position and location, the installer must follow this manual and consider the safety of future users.
15. Keep children away from the battery and related systems to prevent contact or misuse.
16. The battery automatically stops charging when the internal temperature reaches the low temperature threshold of 32°F. If you observe charging current when the internal battery temperature is below 32°F, immediately disconnect the battery and contact the distributor.



## **WARNING!**

Cancer And Reproductive Harm – Visit [www.P65Warnings.ca.gov](http://www.P65Warnings.ca.gov) for more details.

## **DISCLAIMER**

EG4® reserves the right to make changes to the material herein at any time without notice. Refer to [www.eg4electronics.com](http://www.eg4electronics.com) for the most updated version of our manuals/spec sheets.



## TAKE THESE ADDITIONAL PRECAUTIONS DURING INSTALLATION/REPLACEMENT

***Ensure that all precautions listed above have been taken prior to beginning the installation and observe these additional precautions during installation. Failure to take these precautions may result in serious injury or death:***



- ***Thermal Runaway: Immediately stop the installation, place battery in a safe state if possible, and move away from the battery if the battery:***
  - *begins to swell or bulge,*
  - *if you smell any unusual odors,*
  - *if you hear a hissing sound, or*
  - *if the battery begins to emit heat and/or smoke.*

***Your battery may be experiencing thermal runaway, a dangerous condition that may cause fire or explosion. Contact local fire department, Chemtrec 800-262-8200, and EG4 support.***



- ***Electrical Shock: When installing/replacing the battery:***
  - *Ensure that the battery does not get wet.*
  - *Do not spray water or other liquids on the battery.*
  - *Do not perform the installation in conditions where dust, moisture, or other debris could enter the battery.*
  - *Avoid touching connections and components unless instructed to do so by this guide.*
  - *Do not leave the battery unattended during the installation without it being in a safe state. Do not touch, lean on, or lay tools on the battery or connections.*

***If you are electrically shocked during installation, place battery in a safe state if possible, and seek immediate medical attention.***



- **Ventilation Warning:** *When installing/replacing the battery:*
  - *Do not open the battery.*
  - *Do not attempt the installation/replacement if the battery is damaged.*

*Lithium batteries may emit toxic gases when ruptured. Do not attempt to repair the battery in the case of rupture. Move outdoors in the case of rupture and seek professional assistance.*



- **Electrolyte Exposure:** *When installing/replacing the battery:*
  - *Ensure that the battery is not damaged.*
  - *Do not attempt the installation/replacement if the battery is damaged.*

*Lithium batteries contain a liquid electrolyte solution that is corrosive and damaging to skin and eyes. Exposure may occur in the case of damage to the battery. In the case of contact with skin or eyes, wash continuously with water for 15 minutes and seek immediate medical attention. Remove contaminated clothes immediately. In the case of ingestion, drink at least two glasses of water or milk, induce vomiting if unconscious, and seek immediate medical attention.*

## 4. SÉCURITÉ DE LA BATTERIE

### 4.1 CONSIGNES DE SÉCURITÉ

Avant de commencer tout travail, lisez attentivement toutes les consignes de sécurité et respectez-les toujours lorsque vous travaillez sur ou avec la batterie. L'installation doit être conforme à toutes les normes et réglementations nationales ou locales applicables. Consultez l'autorité compétente locale et/ou le service public pour obtenir les permis et les autorisations appropriés avant l'installation.

#### Une installation incorrecte peut entraîner les effets suivants :

- *Blessure ou décès de l'installateur, de l'exploitant ou d'un tiers*
- *Domages à la batterie ou à tout autre équipement attaché*

### 4.2 NOTIFICATIONS DE SÉCURITÉ IMPORTANTES



#### **DANGER: Circuits à haute tension!**

Il existe divers problèmes de sécurité qui doivent être soigneusement observés avant, pendant et après l'installation, ainsi que lors de l'utilisation et de la maintenance futures. Ce qui suit sont des notifications de sécurité importantes pour l'installateur et tout utilisateur final de ce produit dans des conditions de fonctionnement normales.

1. **Ne démontez pas la batterie.** Contactez le distributeur pour tout problème nécessitant une réparation pour plus d'informations et des instructions de manipulation appropriées. Un entretien ou un remontage incorrect peut entraîner un risque d'électrocution ou d'incendie et annuler la garantie.
2. **Ne court-circuitez jamais les entrées CC.** Un court-circuit de la batterie peut entraîner un risque d'électrocution ou d'incendie et peut entraîner des blessures graves ou la mort et/ou des dommages permanents à l'appareil et/ou à tout équipement connecté.
3. **Soyez prudent lorsque vous travaillez avec des outils métalliques sur ou à proximité des batteries et des systèmes.** Le risque d'arcs électriques et/ou de court-circuit de l'équipement peut entraîner des blessures graves ou la mort et des dommages à l'équipement.
4. **Attention au courant de batterie élevé.** Assurez-vous que les disjoncteurs du module de batterie et/ou les interrupteurs marche/arrêt sont en position « ouvert » ou « arrêt » avant d'installer ou de travailler sur la batterie. Utilisez un voltmètre pour confirmer qu'il n'y a pas de tension présente afin d'éviter les chocs électriques.
5. **N'effectuez aucune connexion ou déconnexion du système pendant que les batteries fonctionnent.** Des dommages aux composants du système ou un risque d'électrocution peuvent survenir si vous travaillez avec des batteries sous tension.
6. Assurez-vous que le banc de batteries est correctement mis à la terre.
7. Un installateur doit s'assurer d'être bien protégé par un équipement isolant raisonnable et professionnel [par exemple, un équipement de protection individuelle (EPI)].
8. Avant d'installer, d'utiliser ou d'entretenir le système, il est important d'inspecter tout le câblage existant pour s'assurer qu'il répond aux spécifications et aux conditions d'utilisation appropriées.
9. Assurez-vous que les connexions de la batterie et des composants du système sont sécurisées et appropriées pour éviter les dommages ou les blessures causés par une mauvaise installation.
10. La rupture de la batterie et le court-circuit des cellules de la batterie peuvent causer la libération de gaz toxiques et de solutions électrolytiques nocives.



## **AVERTISSEMENT : Pour réduire le risque de blessure, lisez toutes les instructions !**

Tous les travaux sur ce produit (conception du système, installation, fonctionnement, réglage, configuration et maintenance) doivent être effectués par du personnel qualifié. Pour réduire le risque d'électrocution, n'effectuez aucun entretien autre que ceux spécifiés dans le mode d'emploi, à moins d'être qualifié pour le faire.

11. Lisez toutes les instructions avant de commencer l'installation. Pour les travaux électriques, suivez toutes les normes de câblage locales et nationales, les réglementations et ces instructions d'installation. Tout le câblage doit être conforme au Code national de l'électricité (NEC), ANSI/NFPA 70.
12. La batterie et le système ne peuvent se connecter au réseau public que si le fournisseur d'électricité l'autorise. Consultez l'AHJ local avant d'installer ce produit pour connaître les réglementations et exigences supplémentaires de la région.
13. Toutes les étiquettes d'avertissement et les plaques signalétiques de cette batterie doivent être clairement visibles et ne doivent pas être retirées ou couvertes.
14. L'installateur doit tenir compte de la sécurité des futurs utilisateurs lors du choix de la position et de l'emplacement corrects de la batterie, comme spécifié dans ce manuel.
15. Tenez les enfants à l'écart de la batterie et des systèmes concernés ou de les utiliser à mauvais escient.
16. La batterie est conçue pour arrêter de se charger lorsqu'elle atteint le seuil bas de 32 °F. Si un courant de charge est observé lorsque la température interne de la batterie est inférieure à 32 °F, débranchez immédiatement la batterie et consultez le distributeur.



## **AVERTISSEMENT !**

Cancer et dommages reproductifs – Voir [www.P65Warnings.ca.gov](http://www.P65Warnings.ca.gov) pour plus de détails.

## **DISCLAIMER**

EG4® se réserve le droit de modifier le contenu de ce document à tout moment sans préavis. Veuillez consulter [www.eg4electronics.com](http://www.eg4electronics.com) pour la version la plus récente de nos manuels/fiches techniques.



## **PRENEZ CES PRÉCAUTIONS SUPPLÉMENTAIRES LORS DE L'INSTALLATION OU DU REMPLACEMENT**

**Assurez-vous que toutes les précautions énumérées ci-dessus ont été prises avant de commencer l'installation et respectez ces précautions supplémentaires pendant l'installation. Le non-respect de ces précautions peut entraîner des blessures graves ou la mort.**



- **Emballement thermique:** Arrêtez immédiatement l'installation, mettez la batterie dans un état sécuritaire si possible et éloignez-vous de la batterie si celle-ci :
  - commence à gonfler ou à se déformer,
  - dégage des odeurs inhabituelles,
  - émet un sifflement, ou
  - commence à dégager de la chaleur et/ou de la fumée.

**La batterie peut être en situation d'emballement thermique, une condition dangereuse pouvant entraîner un incendie ou une explosion.**

**Communiquez avec le service d'incendie local, Chemtrec au 800-262-8200, et le soutien EG4.**



- **Choc électrique:** Lors de l'installation ou du remplacement de la batterie :
  - Assurez-vous que la batterie ne soit pas mouillée.
  - Ne vaporisez pas d'eau ni d'autres liquides sur la batterie.
  - N'effectuez pas l'installation dans des conditions où de la poussière, de l'humidité ou d'autres débris pourraient pénétrer dans la batterie.
  - Évitez de toucher les connexions et les composants sauf indication contraire dans ce guide.
  - Ne laissez pas la batterie sans surveillance pendant l'installation si elle n'est pas dans un état sécuritaire
  - Ne touchez pas la batterie, ne vous appuyez pas dessus et ne déposez pas d'outils sur la batterie ou les connexions.

**En cas de choc électrique pendant l'installation, mettez la batterie dans un état sécuritaire si possible et consultez immédiatement un professionnel de la santé.**



- **Avertissement – Ventilation:** Lors de l'installation ou du remplacement de la batterie :
  - N'ouvrez pas la batterie.
  - N'effectuez pas l'installation ou le remplacement si la batterie est endommagée.

**Les batteries au lithium peuvent émettre des gaz toxiques en cas de rupture. N'essayez pas de réparer la batterie si elle est rompue. En cas de rupture, déplacez-vous à l'extérieur et demandez l'assistance d'un professionnel qualifié.**



- **Exposition à l'électrolyte :** Lors de l'installation ou du remplacement de la batterie :
  - Assurez-vous que la batterie n'est pas endommagée.
  - N'effectuez pas l'installation ou le remplacement si la batterie est endommagée.

**Les batteries au lithium contiennent une solution d'électrolyte liquide corrosive et nocive pour la peau et les yeux. Une exposition peut survenir si la batterie est endommagée. En cas de contact avec la peau ou les yeux, rincez abondamment à l'eau pendant 15 minutes et consultez immédiatement un professionnel de la santé. Retirez immédiatement les vêtements contaminés. En cas d'ingestion, buvez au moins deux verres d'eau ou de lait, provoquez le vomissement si la personne est consciente, et consultez immédiatement un professionnel de la santé.**

## SYMBOLS USED IN MANUAL



### **WARNING:**

This type of notation indicates that a hazard may pose a risk to human health and safety.



### **DANGER:**

This type of notation indicates a severe hazard that presents an immediate risk of serious injury or death.



### **NOTE:**

This type of notation indicates useful information.



### **IMPORTANT:**

This type of notation indicates that the information provided is important for the installation, operation, and/or maintenance of the equipment. Failure to follow the recommendations in such a notation could result in the equipment warranty being voided.



### **CAUTION:**

This type of notation indicates that the hazard could potentially damage the equipment.



### **REMINDER:**

This type of notation indicates previously stated information that should be considered to ensure proper operation and safety.



### **TEAM-LIFT:**

Use team-lift whenever load weight, size, or center of gravity exceeds safe single-person handling limits. Coordinated lifting improves stability, control, and significantly reduces injury risk.

## SYMBOLS USED ON EQUIPMENT

	<p><b>WARNING:</b> Read the instructions before installation, operation, and maintenance of the system.</p>
	<p><b>WARNING:</b> Read the instructions before installation, operation, and maintenance of the system.</p>
	<p><b>WARNING:</b> Hazardous Voltage Circuits</p>

## SYMBOLES UTILISÉS DANS LE MANUEL



### AVERTISSEMENT :

Ce type de signalisation indique qu'un danger peut présenter un risque pour la santé et la sécurité humaines.



### DANGER :

Ce type de signalisation indique un danger grave présentant un risque immédiat de blessures graves, voire mortelles.



### NOTE :

Ce type de notation indique des informations utiles.



### IMPORTANT :

Ce type de notation indique que les informations fournies sont importantes pour l'installation, le fonctionnement et/ou l'entretien de l'équipement. Le non-respect des recommandations figurant dans cette notation pourrait entraîner l'annulation de la garantie de l'équipement.



### PRUDENCE :

Ce type de notation indique que le danger pourrait potentiellement endommager l'équipement.



### NOTE :

Ce type de notation indique des informations utiles.



### RAPPEL :

Ce type de notation indique des informations précédemment mentionnées qui doivent être prises en compte pour garantir un fonctionnement et une sécurité optimaux.



### LEVAGE EN ÉQUIPE :

Utilisez le levage à deux personnes lorsque le poids, la taille ou le centre de gravité de la charge dépasse les limites de manutention sécuritaire pour une seule personne. Un levage coordonné améliore la stabilité, le contrôle et réduit considérablement le risque de blessure.

## SYMBOLES UTILISÉS SUR L'ÉQUIPEMENT



### AVERTISSEMENT :

Lisez les instructions avant l'installation, l'utilisation et l'entretien du système.



### AVERTISSEMENT :

Lisez les instructions avant l'installation, l'utilisation et l'entretien du système.



### AVERTISSEMENT :

Circuits à tension dangereuse.

## 5. PRODUCT OVERVIEW

The EG4<sup>®</sup> WallMount 314Ah All Weather Battery is designed for both indoor and outdoor low-voltage residential energy storage applications. It uses lithium iron phosphate (LiFePO<sub>4</sub>) cells that deliver high safety performance and integrates an intelligent Battery Management System (BMS). The BMS continuously monitors and records each cell's voltage, current, and temperature in real time. It also provides active cell balancing, advanced battery control functions, and multiple built-in safety protections to confirm reliable and secure operation.

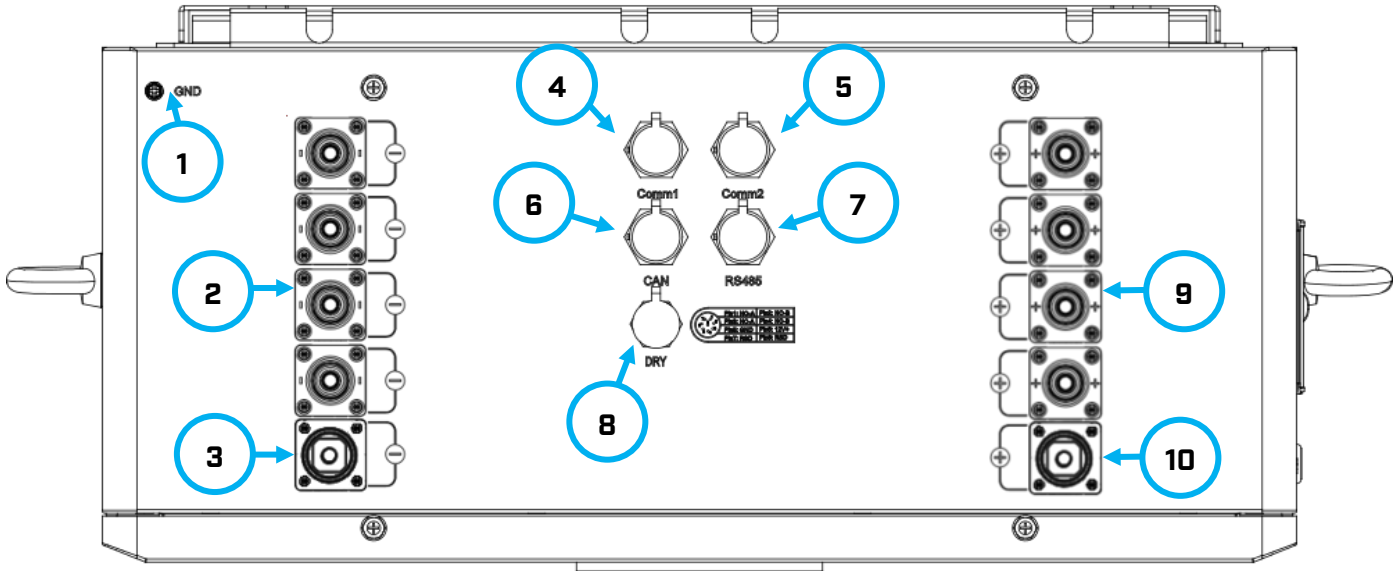

NO.	ITEM	DESCRIPTION	REMARKS
1	GND	Equipment Grounding Conductor (EGC)	For grounding the battery
2	Terminal	Negative × 4	250A rated Degson battery connector
3	Terminal	Negative × 1	250A rated stud terminal
4	Battery Comm 1	Battery Communication Paralleling	For multiple batteries in parallel
5	Battery Comm 2	Battery Communication Paralleling	For multiple batteries in parallel
6	CAN	CAN Communication Interface	For inverter communications
7	RS485	RS485 Communication Interface	For inverter communications
8	Dry Contact	Normally Closed, Normally Open, Ground, RSD, 12V	For RSD control
9	Terminal	Positive × 4	250A rated Degson battery connector
10	Terminal	Positive × 1	250A rated stud terminal

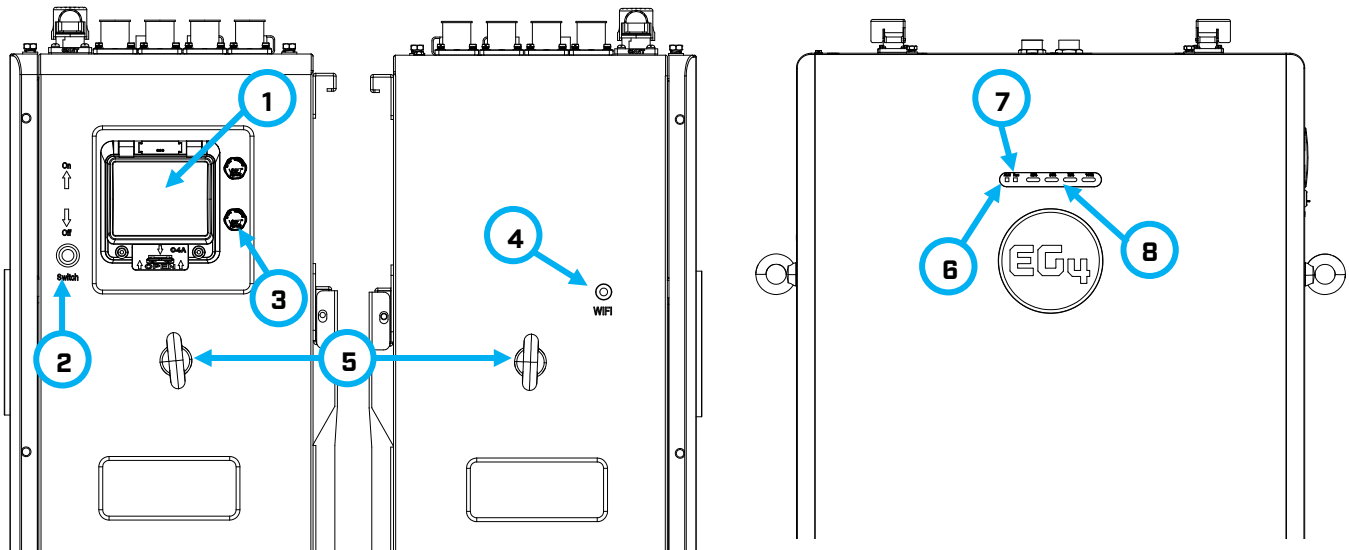

NO.	ITEM	DESCRIPTION	REMARKS
1	Breaker Cover/Breaker	Output switch and over current protection	-
2	ON/OFF Switch	Turn BMS on/off	-
3	Ventilation Valve	Allows excess heat to escape	-
4	Wi-Fi/Bluetooth Antenna	Network connection	-
5	Lifting Eye Bolt	Threaded bolt with circular eye	For moving the battery
6	ALM	Alarm LED Display	To show alarm status
7	RUN	Run LED Display	To show normal operating status
8	SOC	State Of Charge Display	To show battery charge Each LED indicates ~25%

## 5.1 BATTERY DIMENSIONS

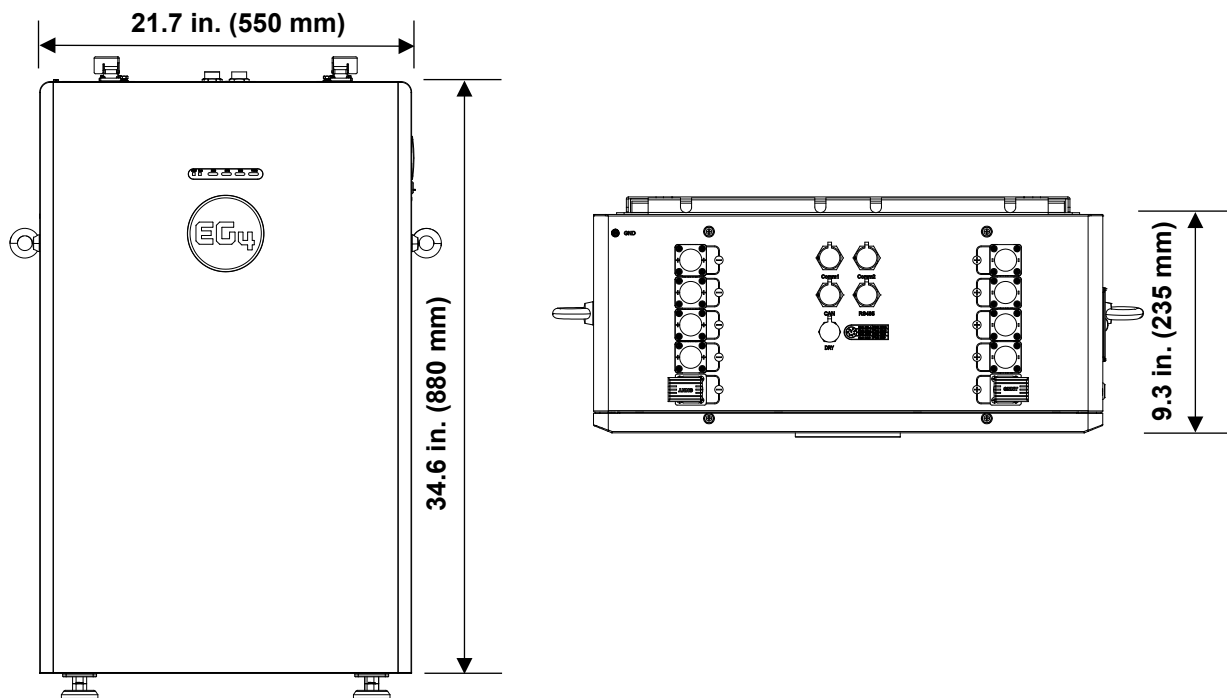

## 5.2 PACKING LIST

The items listed below will arrive with the product shipment:

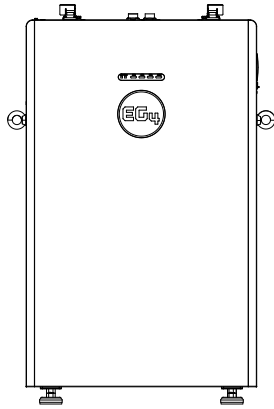

EG4 WallMount 314Ah All Weather Battery (x1)

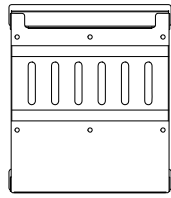

Mounting Bracket (x1)  
(Will come attached to the back of the battery)

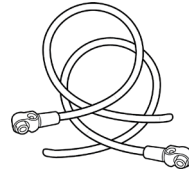

Red and Black Degson power cables (2 set each)  
2/0 AWG (39.4 in.)

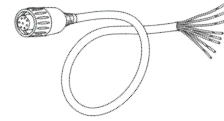

8-pin Outdoor Rated Dry Contact Cable

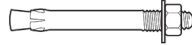

Expansion Bolt (x6)  
M8\*70

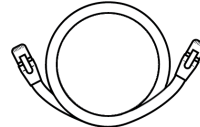

Battery to Inverter Communication Cable (x1)  
(59.1 in.)

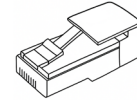

120Ω Terminating Resistor



M10 Lifting Eye Bolt (x2)



Wi-Fi/Bluetooth Antenna

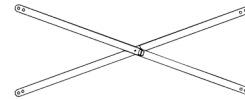

X-Bracket



### DANGER:

When installing or removing the battery verify that the battery is powered off and use a multimeter to confirm there is no voltage present. This will prevent users from encountering live (powered) terminals by accident.

## 5.3 BMS OVERVIEW

The Battery Management System (BMS) protects the battery and its cells from conditions that could damage system components. It applies a 157A charge limit and a 200A discharge limit to help extend battery life and increase the number of usable life cycles. EG4<sup>®</sup> specifically configures each WallMount 314Ah All Weather Battery to deliver peak performance and reliable operation with compatible systems.

### PCB TEMPERATURE PROTECTION

The BMS prevents the Printed Circuit Board (PCB) which houses most of the battery's control electronics from overheating. If the PCB temperature rises beyond safe limits, the BMS automatically shuts down the battery.

### VOLTAGE PROTECTION

The BMS continuously monitors the voltage of each individual cell and prevents overcharging or undercharging.

### ACTIVE CELL BALANCE PROTECTION

Cell balancing automatically keeps each individual cell within a specific voltage range relative to the others. This process optimizes battery performance and extends battery life without requiring any manual intervention.

## ENVIRONMENTAL TEMPERATURE PROTECTION

Operating the battery outside the environmental temperature limits specified on the spec sheet can be dangerous and may cause permanent damage to the battery module and its components. To prevent this, the BMS continuously monitors battery temperature during charging and discharging and automatically shuts down the battery when temperatures exceed safe limits. Refer to Section 6.4 for more information.

## CURRENT PROTECTION

The BMS continuously monitors charge and discharge current and includes built-in safeguards to prevent operation beyond specified limits. These safeguards include rapid shutdown timers for short circuits or extreme overcurrent conditions, as well as delayed shutdown for currents that slightly exceed the maximum rated capacity.

## 5.4 STORAGE INFORMATION

Follow these steps to store the batteries safely and prevent damage during storage.

### BATTERY STATE

The battery's State of Charge (SOC) at the time of storage affects how long it retains its charge. EG4® recommends bringing each battery to a 20 – 50% SOC before placing it in storage. Lithium batteries naturally lose a portion of their charge over time, depending on storage duration and conditions. For best performance, EG4® recommends charging and discharging the batteries every three months.

### ENVIRONMENTAL FACTORS

The battery storage location significantly affects battery health. For best results, store the battery at moderate temperatures between 32°F – 113°F (0°C – 45°C) for up to three months. For storage periods longer than three months, maintain a temperature range of 59°F – 86°F (15°C – 30°C).

If the cell remains in storage for more than six months, adjust its State of Charge (SOC) to 20 – 50% through a controlled charge and discharge process. Maintain storage humidity at or below 90% relative humidity (RH), and keep the storage temperature between 41°F – 77°F (5°C – 25°C).

Keep the battery away from areas where it may get wet or where humidity is high ( $\geq 90\%$ ). **Store the batteries away from all combustible materials.**

## 5.5 BATTERY PERFORMANCE CURVES

Charge & Discharge curve with 0.5C @ 25°C

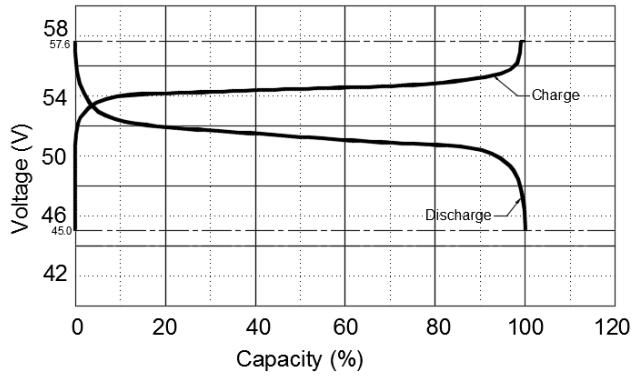

Discharge performance with different rate @ 25°C

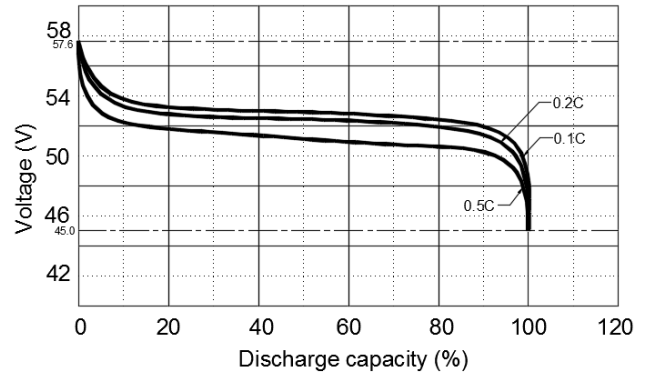

Discharge capacity with different temperature @ 0.5C

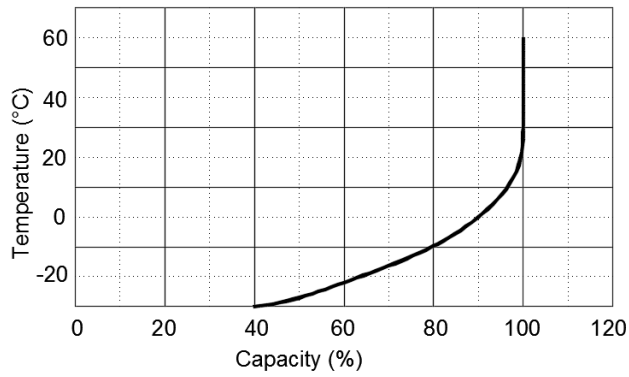

Cycle life with DOD @ 0.5C, 25°C

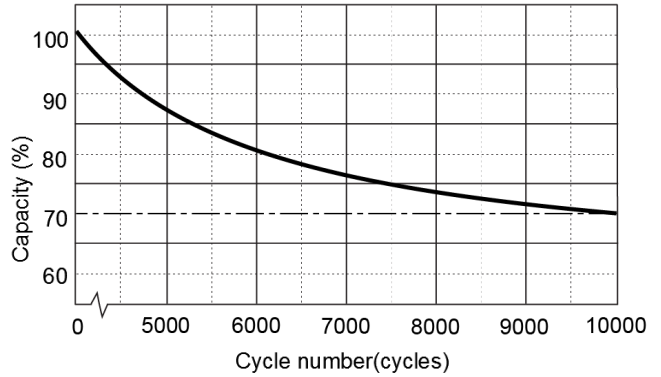

Self-discharge @ different temperature

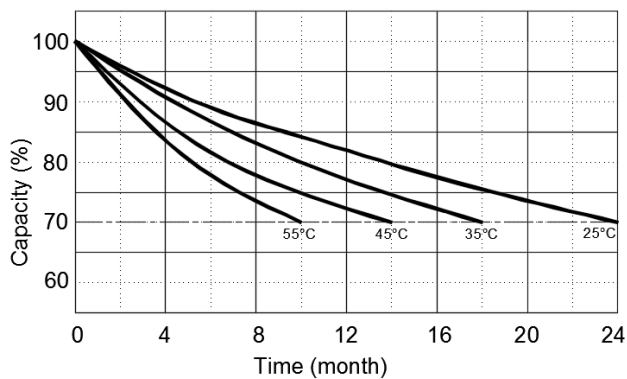

## 5.6 BATTERY CHARGING

Set the correct parameters on the charge controller and/or inverter to prevent overcharging or damage to the battery module. (Refer to Section 1: Technical Specifications for the complete list of charging and discharging parameters.)

It is normal for EG4® WallMount 314Ah All Weather batteries with individual BMS units wired in parallel to display varying State of Charge (SOC) readings during charging or discharging. SOC variations of up to 10% are common. For more information on Battery State of Health (SOH) and Depth of Discharge (DoD), scan the QR code below:



This behavior does not indicate a problem or reduced module capacity. Small differences in wiring resistance, internal resistance, temperature, and individual cell characteristics cause slight SOC variations between batteries. These differences may cause one battery to carry more load or accept more charge for a short period. Over the course of a full charge or discharge cycle, the batteries naturally balance as the lagging battery assumes more load or charge later in the cycle, allowing the system to deliver the full rated kWh capacity. The voltage differences that develop as SOC levels diverge eventually drive the batteries to converge again during the cycle.



### NOTE:

When installing multiple batteries or adding a battery to an existing bank, confirm all batteries are charged to 100% before paralleling. This step is crucial to optimizing battery performance.

## 5.7 FRONT PANEL INDICATOR LIGHTS

The WallMount 314Ah All Weather Battery includes two status indicator LEDs and four State of Charge (SOC) indicator LEDs on the front panel. Their functions are described below:



1. **ALM** – The ALM light illuminates solid red when a fault occurs. Refer to Section 13 for details on specific faults and the required corrective actions.
2. **Run** – The RUN light displays a solid green color when the battery is idle. When the battery is charging or discharging, the RUN light blinks green.
3. **25%/50%/75%/100%** – The SOC indicator lights display the battery charge level in 25% increments. A red 25% light indicates 0 - 15% SOC, while a green 25% light indicates 16 - 25% SOC. A green 50% light, with all preceding lights illuminated green, indicates 26 - 50% SOC. A green 75% light, with all preceding lights illuminated green, indicates 51 - 75% SOC. A green 100% light, with all preceding lights illuminated green, indicates 76 - 100% SOC.



### NOTE:

See section 10.1 for full LED indicator status and definition.

## 6. GENERAL INSTALLATION

This section outlines the detailed steps for installing and configuring the battery. Follow each section in the order listed below for proper installation and setup.

### INSTALLATION STEPS

- 6.1 Recommended Tools
- 6.2 Location Requirements
- 6.3 Battery Installation
- 6.4 Battery and Conduit Box
- 6.5 Battery and Conduit Box with EG4® 18kPV
- 6.6 Battery and Conduit Box with EG4® 12kPV/FlexBOSS18/21

### 6.1 RECOMMENDED TOOLS



Safety Goggles



Dielectric Shoes



Gloves



Multimeter



Phillips Head  
Screwdriver

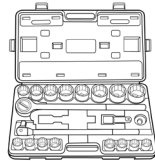

Socket Set



Electric Drill and  
Drill Bits



Flathead  
Screwdriver

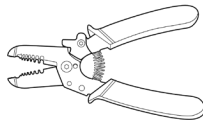

Wire Stripper



Level

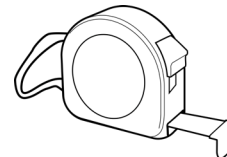

Tape Measure

## 6.2 LOCATION REQUIREMENTS

Requirements for installation location:

- The EG4® WallMount 314Ah All Weather Battery is heavy. Use an equipment lift or a team-lift technique when moving the battery.
- The battery is designed for both indoor and outdoor installation. For indoor residential use, install the unit only in attached or detached garages, sheds, enclosed utility closets, basements, or other designated storage or utility spaces within the dwelling. Do not install the unit in habitable or living spaces, and do not install it in or near marine environments.
- You may install the battery against a flat wall, but do not allow the wall to support the full weight of the unit. Use the pre-installed feet to confirm that part of the battery's weight rests on the ground.
- When installing the battery on flat ground, check for proper drainage around the installation area to reduce the risk of damage from flooding.
- Based on UL 9540A testing, the manufacturer recommends a minimum spacing of 4 inches between WallMount 314Ah All Weather batteries (see Intertek/ETL Test Report 250820046GZC-001). Before installation, consult the Authority Having Jurisdiction (AHJ) to determine whether reduced spacing is permitted. If reduced spacing is not allowed, follow all applicable state and local building and fire code spacing requirements.
- Confirm that the installation location maintains a minimum clearance of 23.6 in. (600 mm) from all exposures and egress points.
- Install the battery in an upright position.
- Consult applicable state and local building, fire, and installation codes to determine required smoke alarm provisions.



### IMPORTANT:

Provide a minimum installation space volume of 50 m<sup>3</sup> when ventilation is not available. This volume keeps flammable gas concentrations below 25% of the Lower Flammable Limit (LFL) in the event of thermal runaway. The required room volume is based on the amount of gas released and the number of battery cells affected during testing. Adding additional EG4® WallMount 314Ah All Weather batteries does not require a larger installation space, as testing confirmed no thermal propagation between units. You may reduce the required installation volume by providing adequate ventilation in accordance with applicable codes and jurisdictional requirements.



### WARNING:

Do not make any electrical connections until the battery is in its final location.



### TEAM-LIFT:

The battery is very heavy. Use the team-lift technique during installation.

## 6.3 BATTERY INSTALLATION

Maintain a minimum clearance of 4 in. (101.6 mm) between batteries when installing them without a conduit box.



### NOTE:

When using an equipment lift to move the battery, secure M10 lifting eye bolts (included with purchase) to both sides of the battery.

1. Remove the four set screws that secure the mounting bracket to the back of the battery, and set them aside.
2. Remove the mounting bracket from the battery and set it aside.

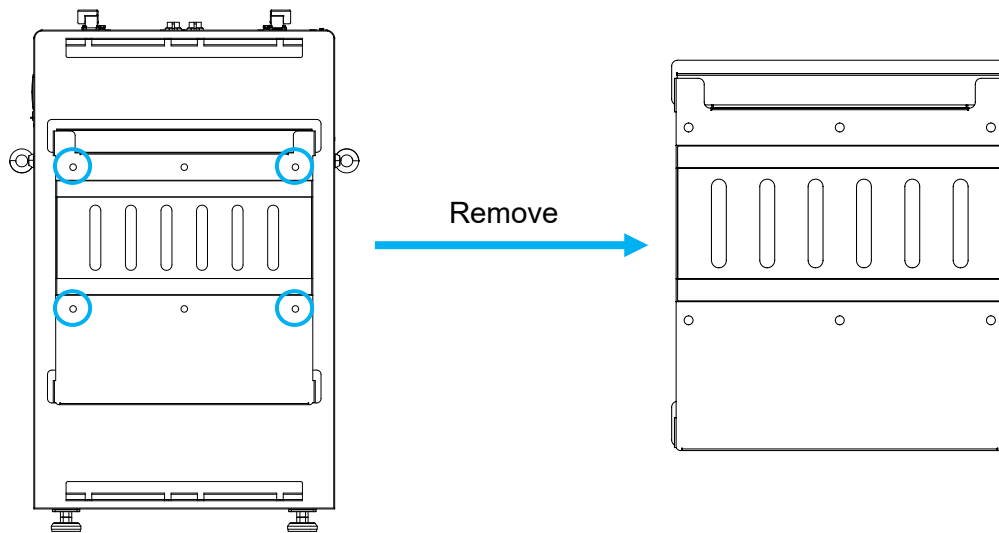

3. Position the top of the mounting bracket on the wall at the desired mounting height, maintaining a minimum clearance of 28.8 in. (731.5 mm) from the ground.

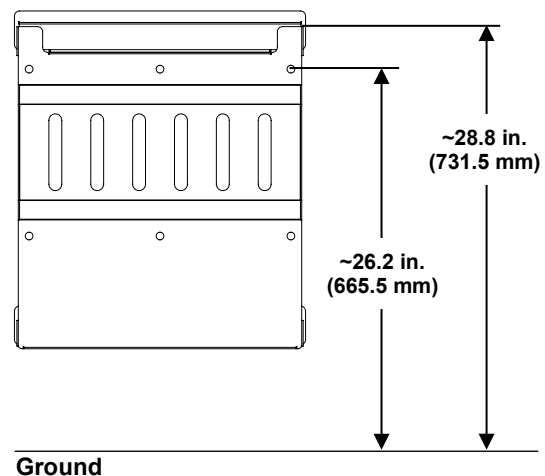

4. Use a level to align the bracket with the ground, then drill six holes to accommodate the mounting hardware.

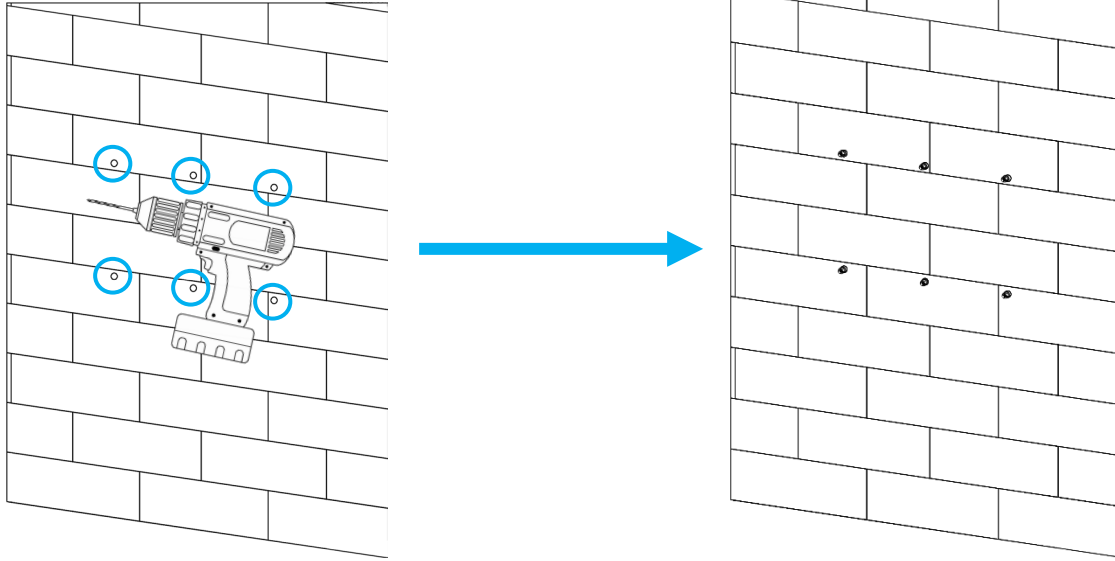

5. Secure the mounting bracket to the wall using hardware appropriate for the mounting surface. Use the included expansion bolts when mounting to concrete or brick.

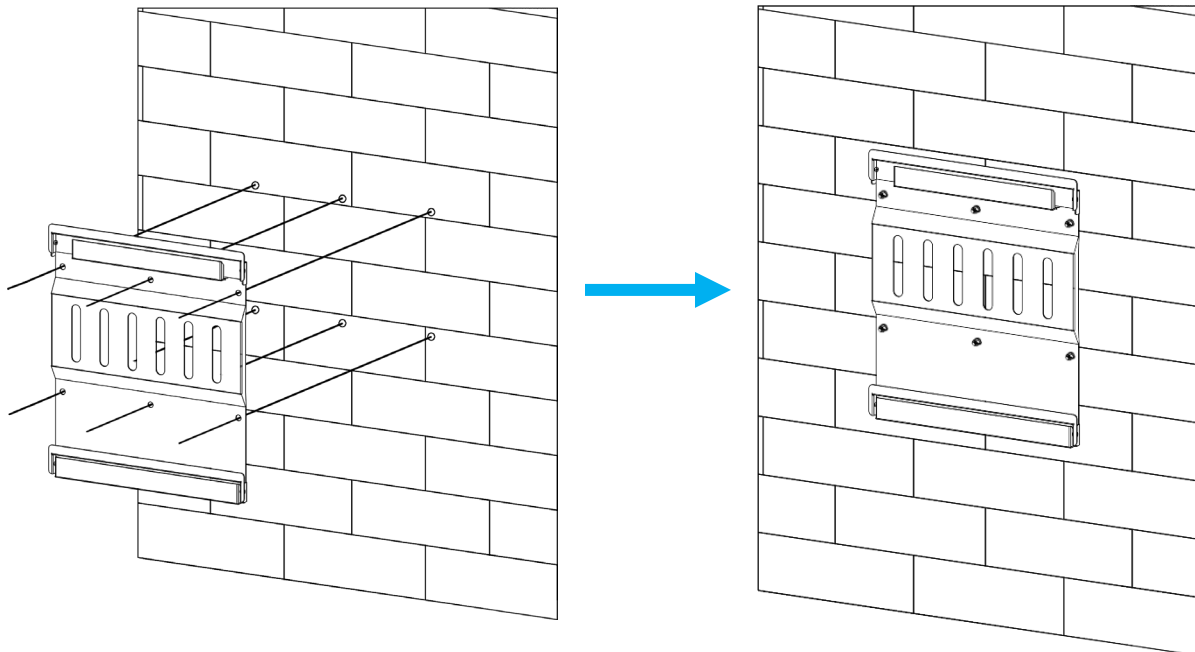

6. Attach the battery to the mounting bracket. Using a team-lift technique, lift the battery and hook the rear flange of the battery onto the front flange of the mounting bracket.



## TEAM-LIFT:

The battery is very heavy. Use a team-lift technique to prevent injury to personnel or damage to equipment. The feet support the battery's weight not the wall bracket so verify that the feet rest firmly on the ground.

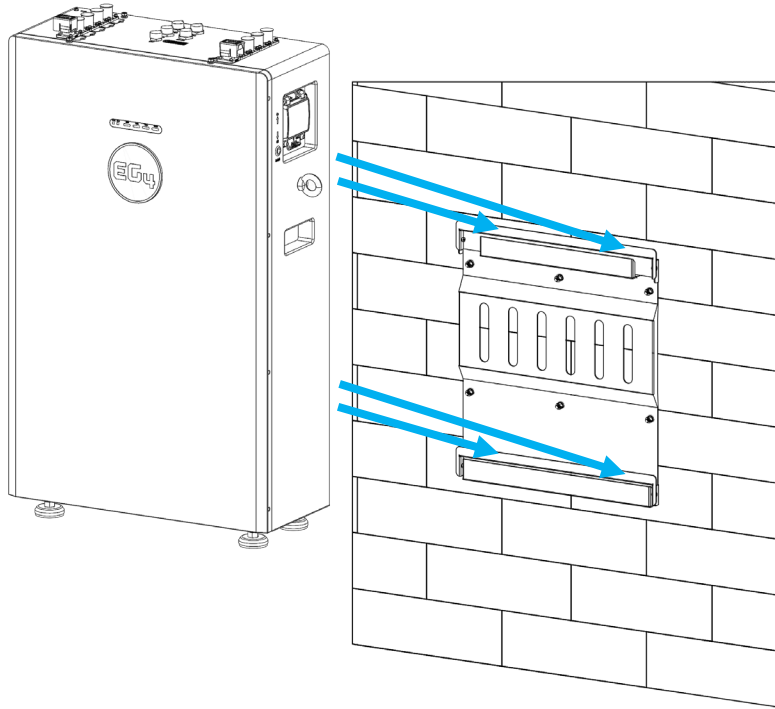

7. Secure the battery to the mounting bracket using the four side screws removed in Step 1.

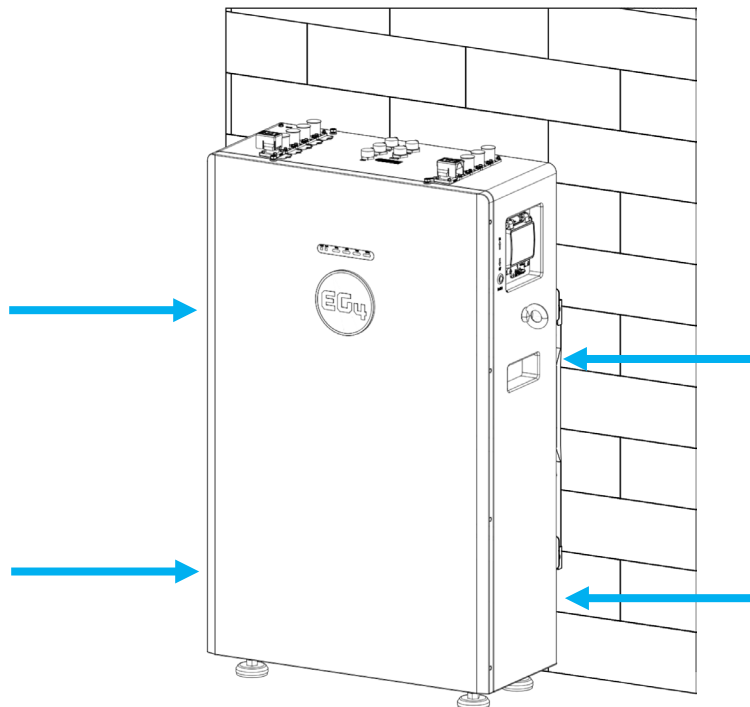

8. After securing the battery, attach the Wi-Fi/Bluetooth antenna to the left side of the battery.

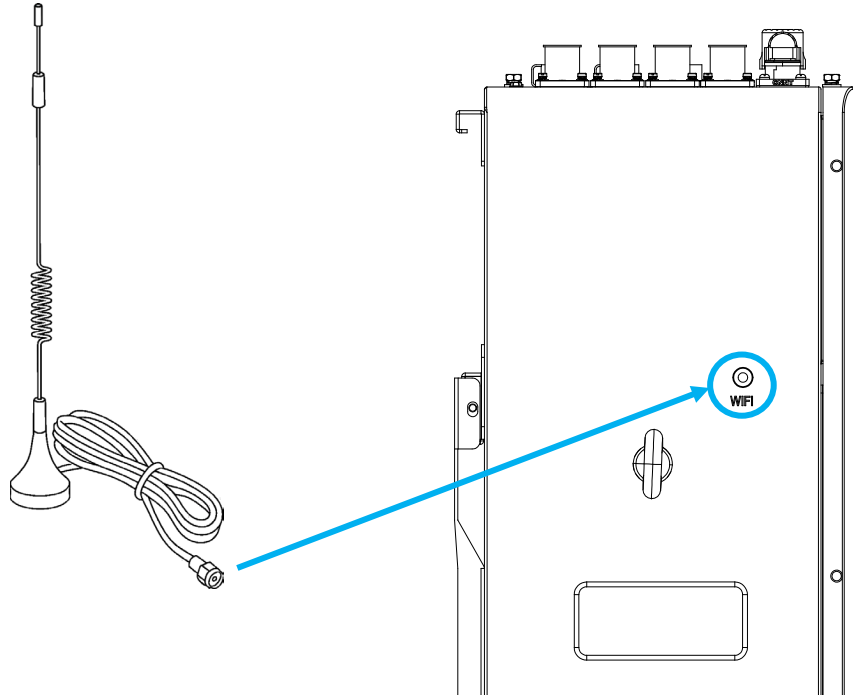

## 6.4 BATTERY WITH CONDUIT BOX

If users install the battery with the optional WallMount All Weather Conduit Box, follow the steps below starting from Step 8 in the previous section. When using the EG4® WallMount All Weather conduit box, maintain a spacing of 5.35 in. (135.9 mm) between batteries.

1. Remove the four screws from the top of the battery, as shown in the image below, and retain them for use in Step 2.

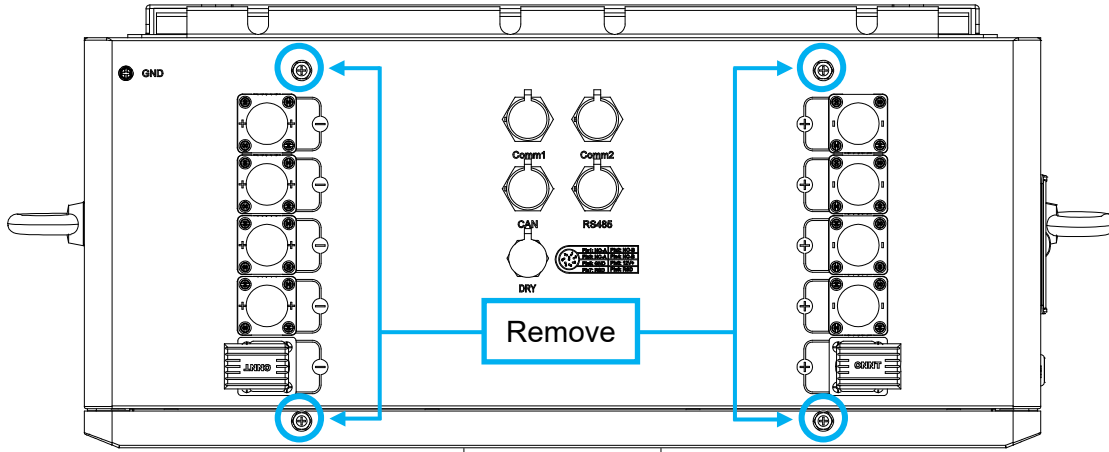

### NOTE:

Refer to the EG4® WallMount All Weather Conduit Box quick start guide at [www.eg4electronics.com](http://www.eg4electronics.com) for assembly instructions or scan the QR code below.



2. Identify the four screw locations on the bottom of the WallMount All Weather Conduit Box that align with the screw holes on the top of the WallMount 314Ah All Weather battery. Place the conduit box on top of the battery and secure it using the screws removed in Step 1.

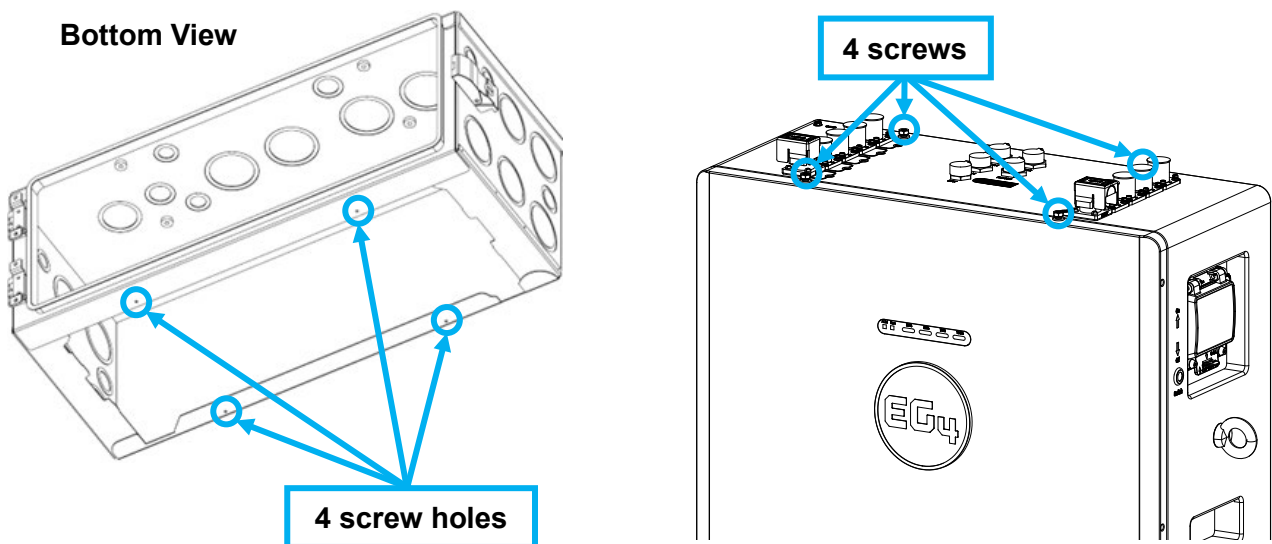

3. Attach the grounding conductor from the M6 grounding screw on top of the battery to the Equipment Grounding System to properly ground the battery.

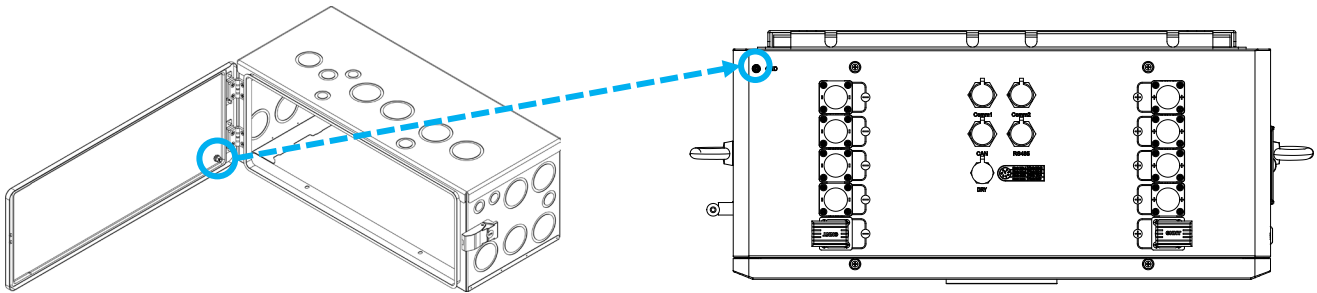

The image below represents a complete install:

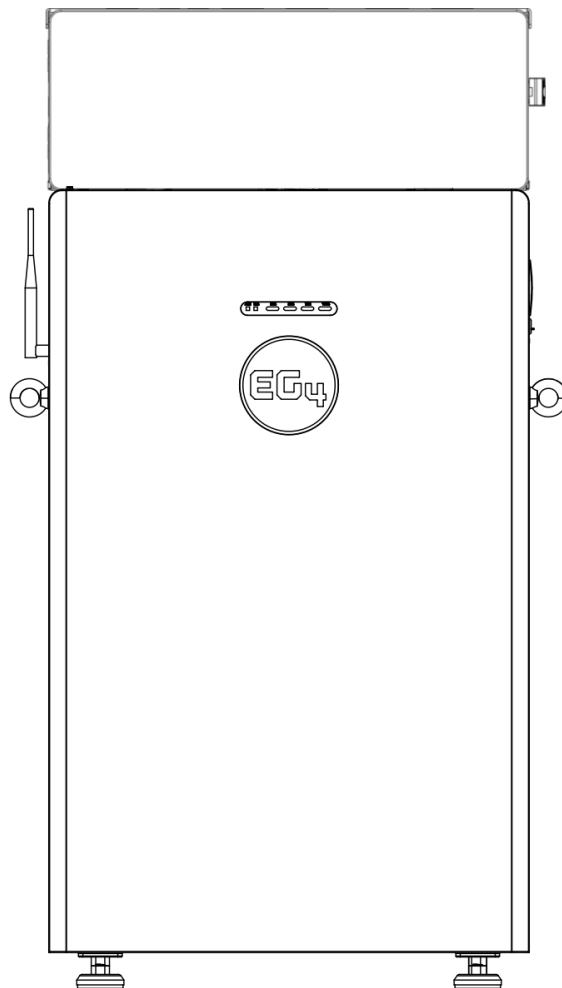

## 6.5 BATTERY, CONDUIT BOX, & 18KPV

After completing Step 3 in Section 7.4, follow the instructions below to install the system with an 18kPV inverter and the WallMount All Weather Conduit Box:

1. Align the included X-bracket with the drilled holes and mount both the battery bracket and the X-bracket to the wall, positioning the X-bracket against the wall.
2. Use the uppermost hole on the X-bracket to attach the inverter mounting bracket with hardware appropriate for the mounting surface. Refer to the inverter user manual for additional details.
3. Attach the battery to the mounting bracket. Use a team-lift technique to lift the battery and secure it onto the bracket flanges.
4. Attach the conduit box to the battery as described in Section 7.4.
5. Install the 18kPV onto the inverter mounting bracket (included with the inverter), align the inverter mounting holes with the conduit box, and secure the components together using the included hardware.
6. Properly ground the battery by attaching the grounding conductor from the conduit box to the M6 grounding screw on top of the battery.

*Images for representative purposes only.*

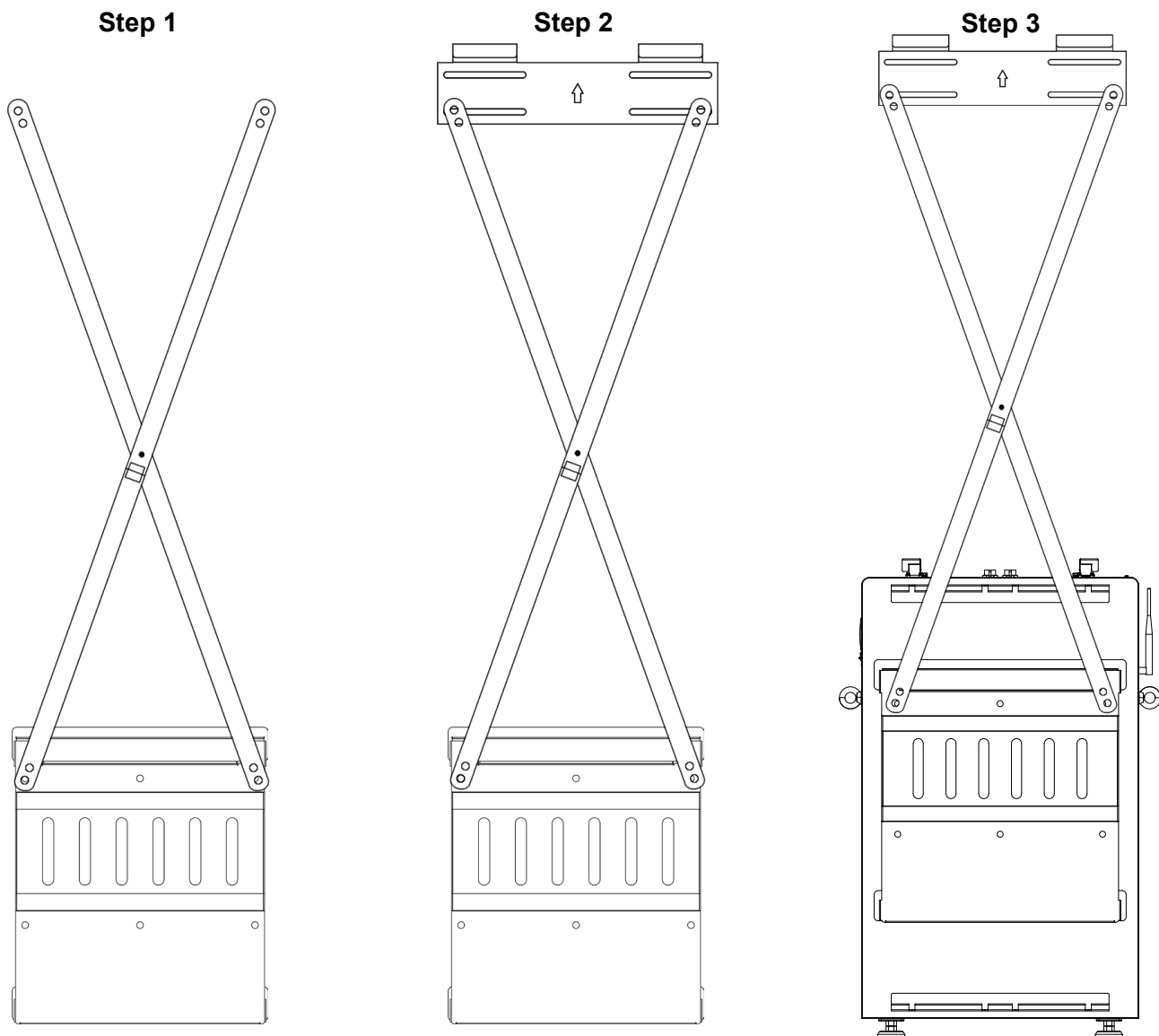

*Images for representative purposes only.*

**Step 4**

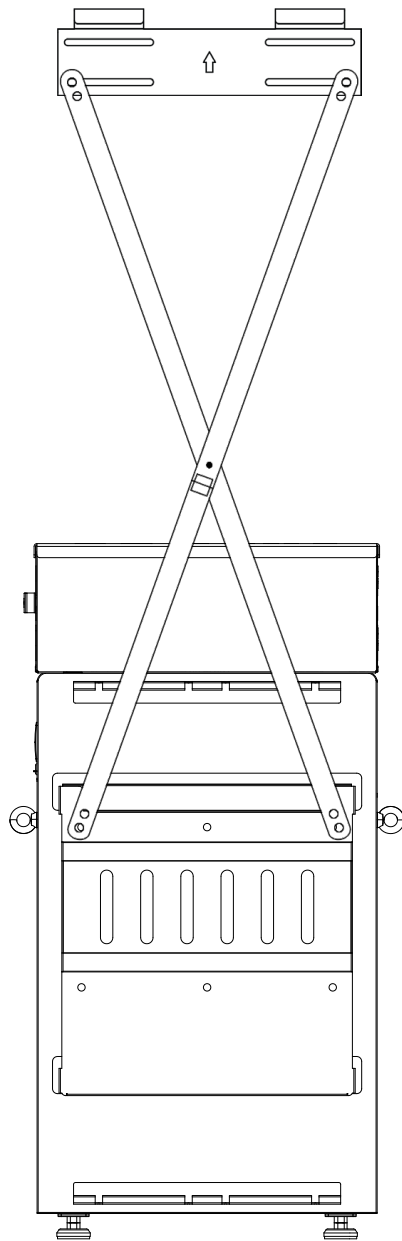

**Step 5**

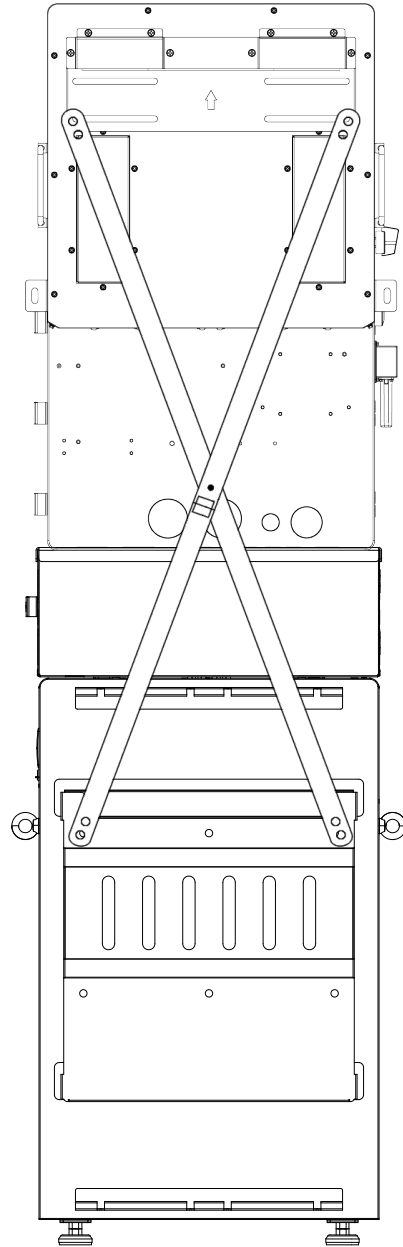

## 6.6 BATTERY, CONDUIT BOX, & 12KPV/FLEXBOSS18/21

After completing Step 3 in Section 7.4, follow the instructions below to install the system with a 12kPV, FlexBOSS18, or FlexBOSS21 inverter and the WallMount All Weather Conduit Box:

1. Align the included X-bracket with the drilled holes and mount both the battery bracket and the X-bracket to the wall, positioning the X-bracket against the wall.
2. Use the lowermost hole on the X-bracket to attach the inverter mounting bracket with hardware appropriate for the mounting surface. Refer to the inverter user manual for additional details.
3. Attach the battery to the mounting bracket. Use a team-lift technique to lift the battery and secure it onto the bracket flanges.
4. Attach the conduit box to the battery as described in Section 7.4.
5. Install the appropriate inverter onto the inverter mounting bracket (included with the inverter). Align the inverter mounting holes with the conduit box and secure the components together using the included hardware.
6. Properly ground the battery by attaching the grounding conductor from the conduit box to the M6 grounding screw on top of the battery.

*Images for representative purposes only.*

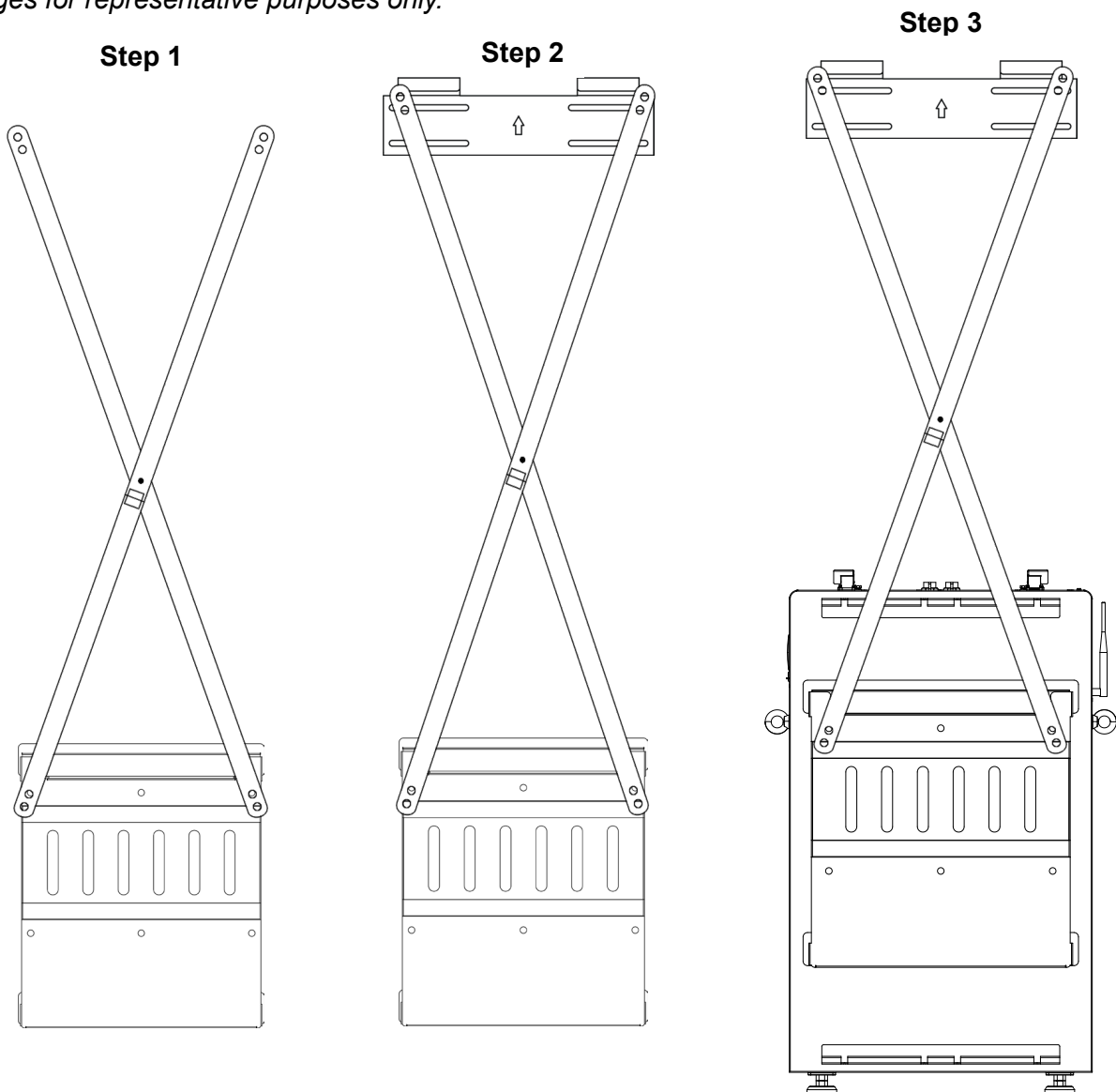

Images for representative purposes only.

**Step 4**

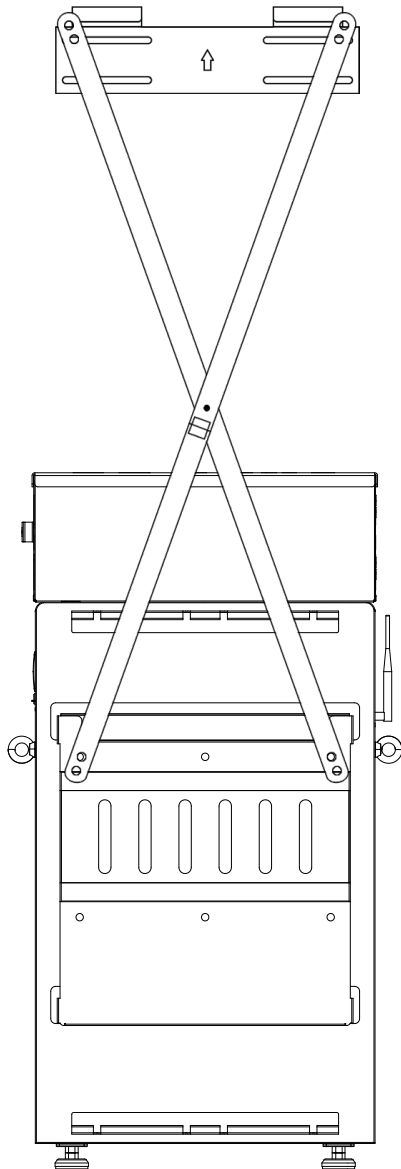

**Step 5**

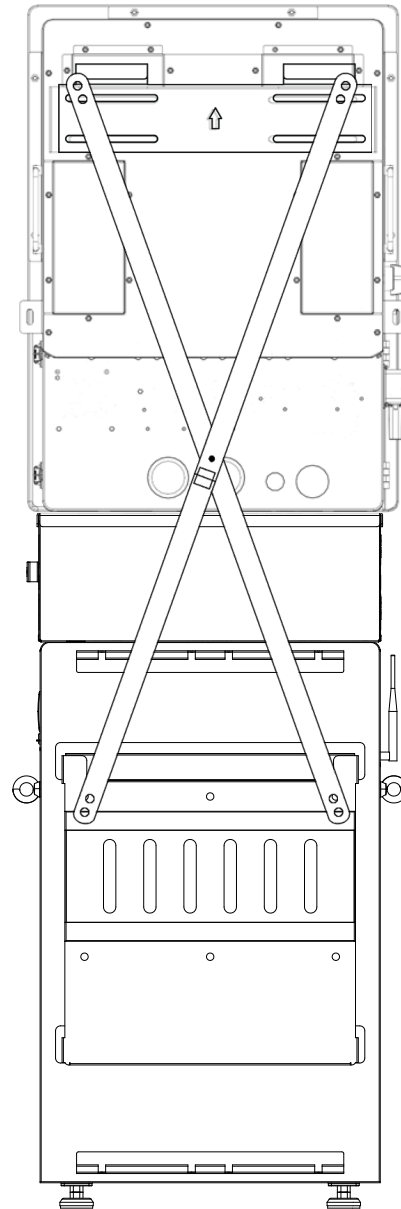

## 7. CONNECTING MULTIPLE BATTERIES IN PARALLEL

When connecting multiple EG4® WallMount 314Ah All Weather batteries in parallel, purchase a paralleling kit from the distributor. Use the battery-to-battery communication cables included in the kit to interconnect and parallel the batteries.



### IMPORTANT:

The battery supports charging up to 157A and discharging up to 200A before the BMS shuts down the battery. Verify that the inverter is properly configured to maintain these charge and discharge limits. If you need to fabricate custom battery power cables, refer to an NEC approved ampacity chart.

### 7.1 BMS COMMUNICATION WIRING

The diagram below illustrates the battery communication cable wiring. Follow the guidelines listed below:

1. Starting at the last battery in the stack, use the included communication cables to connect the batteries in parallel. Plug the cable into the Comm 1 port on the last battery, then daisy chain to the Comm 2 port on the next battery. Repeat this process until the user reaches the master battery.
2. Based on whether the system uses CAN or RS485 communication, connect the battery to inverter communication cable to the CAN or RS485 port on the master battery, then connect the other end to the corresponding communication port on the inverter.
3. Install the included 120Ω terminating resistor into the Comm 1 port on the master battery to “close” the communication loop.
4. Install a second 120Ω terminating resistor into the “Comm 2” port on the last battery in the stack to “close” the communication loop.



### NOTE:

When using closed-loop communication, connect the 120Ω terminating resistor to the Comm 1 port on the master battery. Verify that the resistor is connected to the correct port, as connecting it to the wrong port may damage the system and connected components.

For additional examples of paralleling batteries, refer to the example diagrams on the following page.

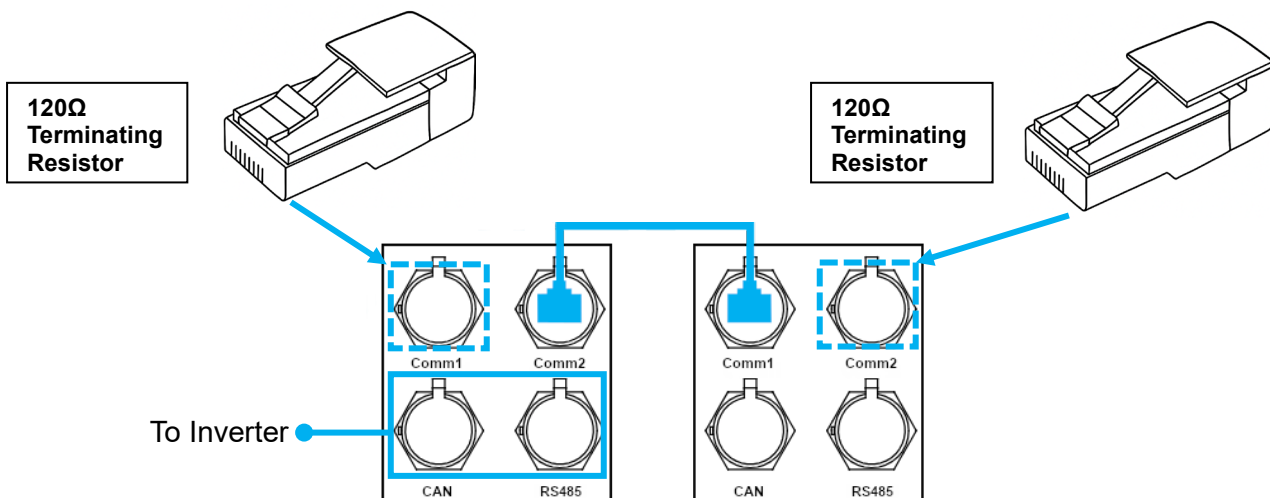

### WARNING:

Do not put EG4® batteries in series! The BMS and internal components are not designed to handle this setup, which could cause the modules to fail, leading to damage.



## NOTE:

The master battery will communicate directly with the system via the CAN/RS485 port.

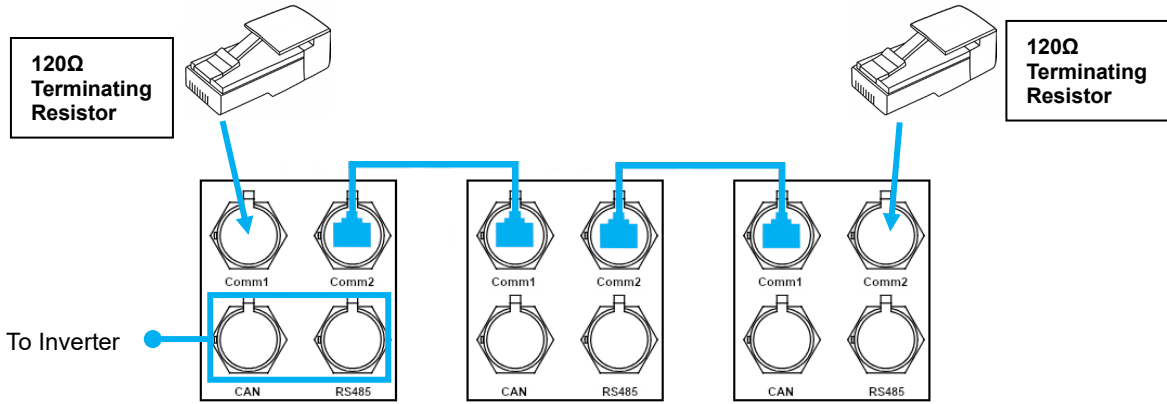

**WallMounts in Parallel x 3**

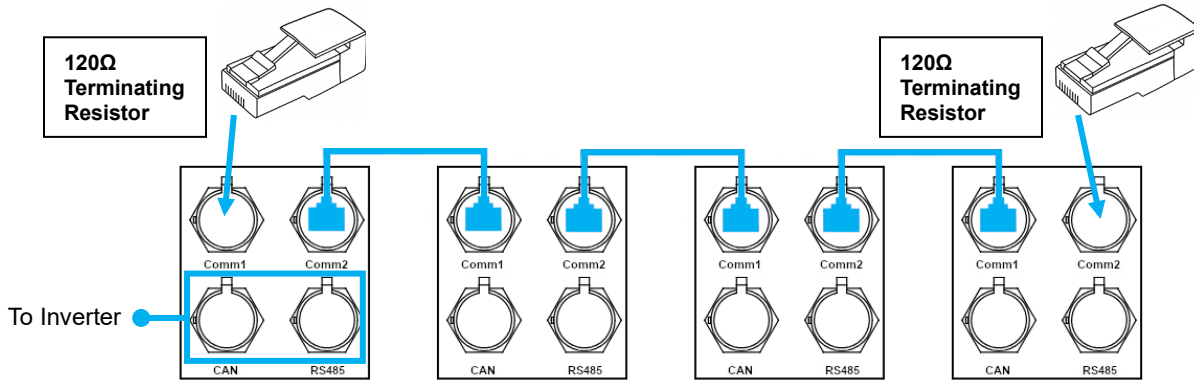

**WallMounts in Parallel x 4**

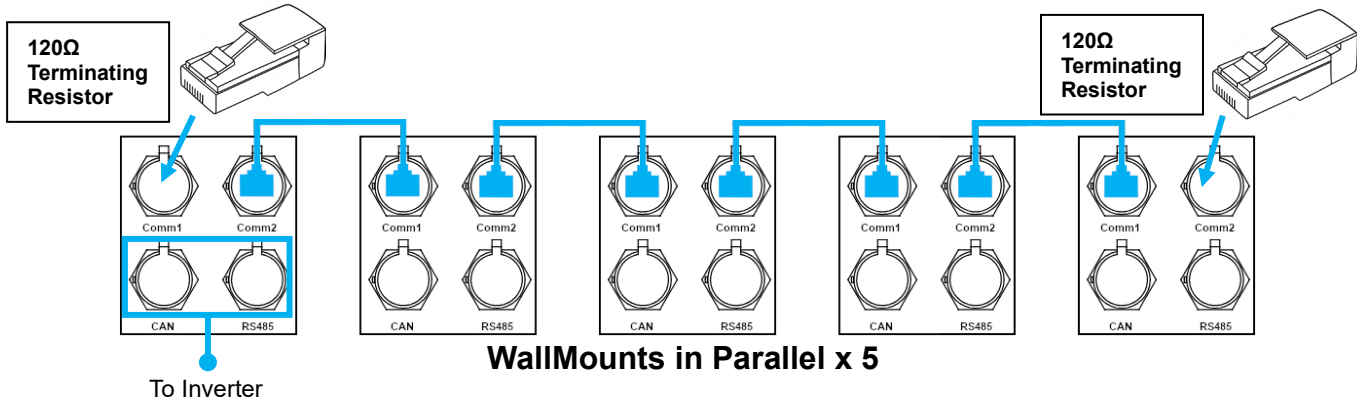

**WallMounts in Parallel x 5**

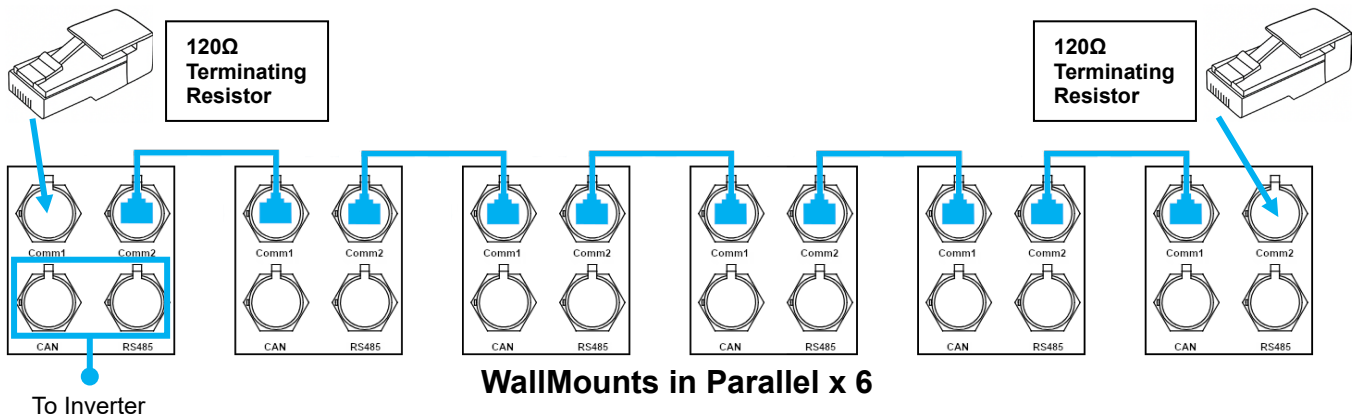

**WallMounts in Parallel x 6**

## 7.2 BATTERY CABLE CONNECTIONS

The following battery cable connection diagrams show how to use the internal busbars to connect batteries in parallel and link them to the inverter(s). When using the internal busbars, the system supports up to six batteries connected in parallel, regardless of whether they are connected to one, two, or three EG4® FlexBOSS21 inverters.

Systems that require more than six batteries connected in parallel must use an external fused positive busbar and an unfused negative busbar, each rated for a minimum of 200A per battery. Each fuse must be rated at no more than 250A. Alternatively, larger systems can take advantage of the FlexBOSS18 and FlexBOSS21's ability to draw power from separate battery packs while still paralleling inverters, instead of relying solely on shared external busbars.



### NOTE:

In the following diagrams, the inverter communications cable connects to the CAN/RS485 port on the FlexBOSS21 inverter, and the units are spaced 4 in. (101.6 mm) apart. Local regulations may require greater minimum battery spacing; verify these requirements with the local AHJ. If the installation requires parallel cables longer than those supplied in the optional paralleling kit, contact the distributor to confirm availability.

*Illustrations for representative purposes only.*

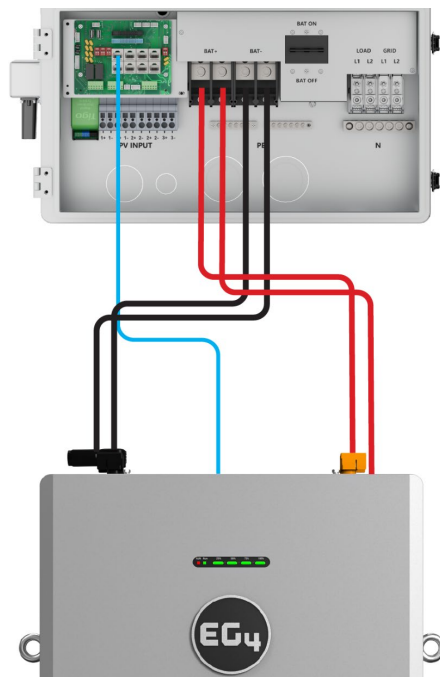

(1) FlexBOSS21 with (1) 314 All Weather





**Note:** To comply with the UL9540 listing for this integrated battery, conduit box, and inverter system, wire the batteries as shown on pages 34 – 38 using the supplied inverter to battery cables. *Each additional battery connected in parallel requires a separate paralleling kit, which is sold separately.*



**Caution:** To minimize voltage drop, keep the battery cables at an optimal length. The 53.1 in. cables supplied with the parallel kit are sufficient for daisy chaining the batteries.

### Color Code

	– Communication Cable
	– Positive Cable
	– Negative Cable



### CAUTION:

When pairing the EG4® WallMount 314Ah All Weather battery with an inverter, do not exceed a 600A load on the master battery, as this exceeds the internal busbar rating.

## ADDITIONAL SINGLE INVERTER CONFIGURATIONS

*Illustrations for representative purposes only.*

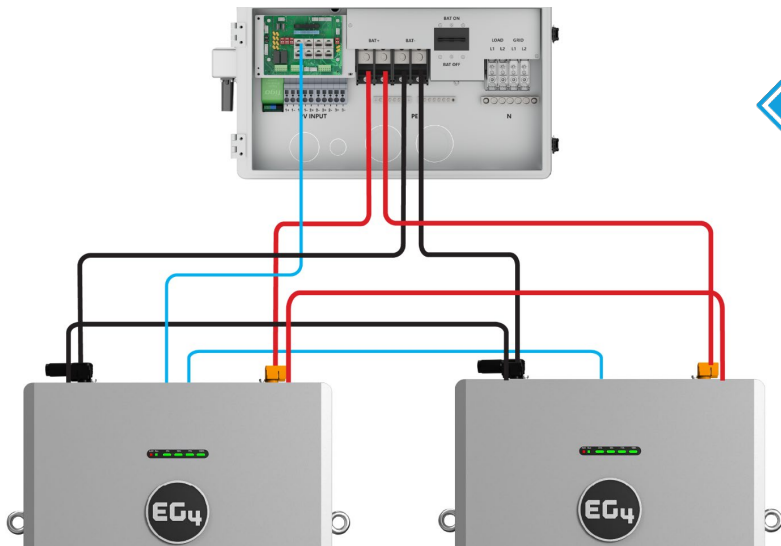

(1) FlexBOSS21 with (2) 314 All Weather



**Note:** Some configurations require additional wiring or connectors to achieve the example layouts. The following diagram does not show the inverter-to-inverter paralleling cables. You can achieve other configurations by using external busbars. Consult an electrician or other qualified personnel to design an optional system layout.



### Reminder!

While installing batteries without a conduit box, maintain a minimum separation of 4 in. (101.6 mm). When using an EG4® WallMount All Weather conduit box, maintain a battery spacing of 5.35 in. (135.9 mm).

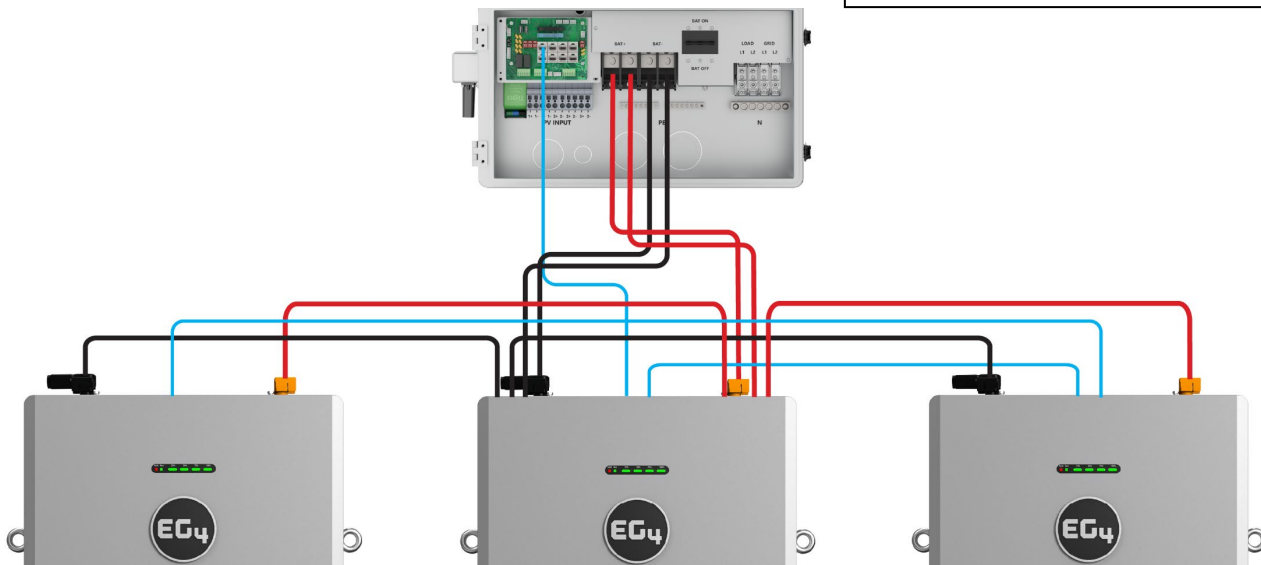

(1) FlexBOSS21 with (3) 314 All Weather

## TWO INVERTER CONFIGURATIONS

*Illustrations for representative purposes only.*

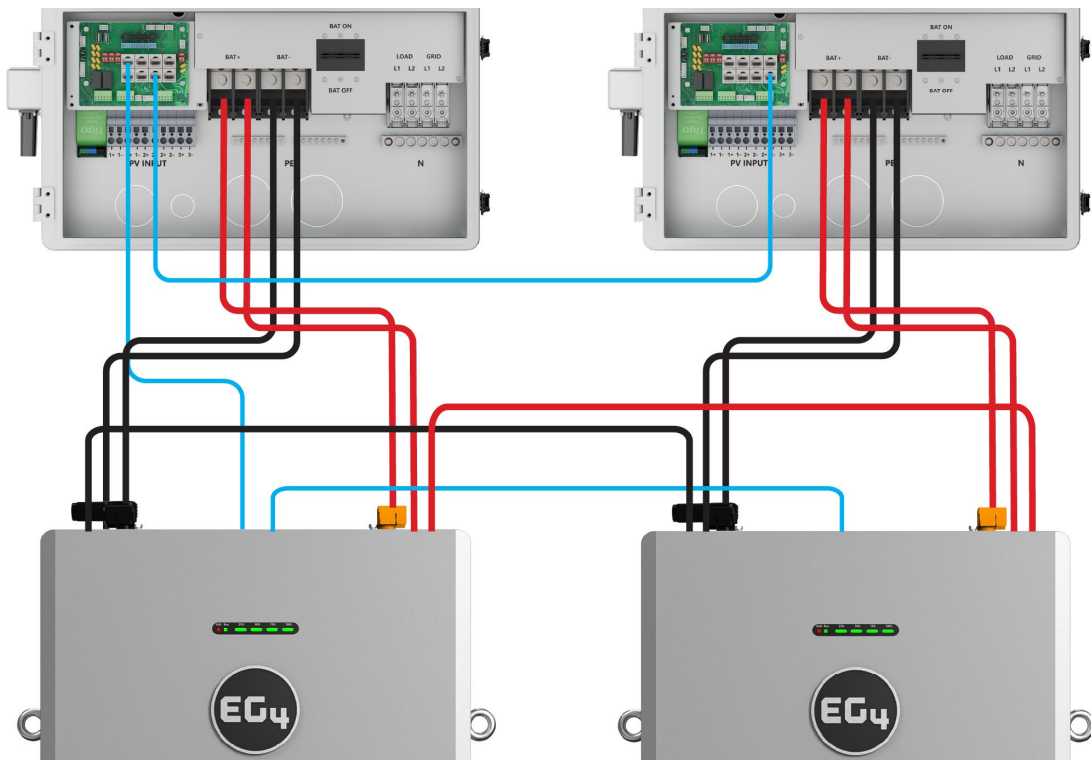

**(2) FlexBOSS21 with (2) 314 All Weather**

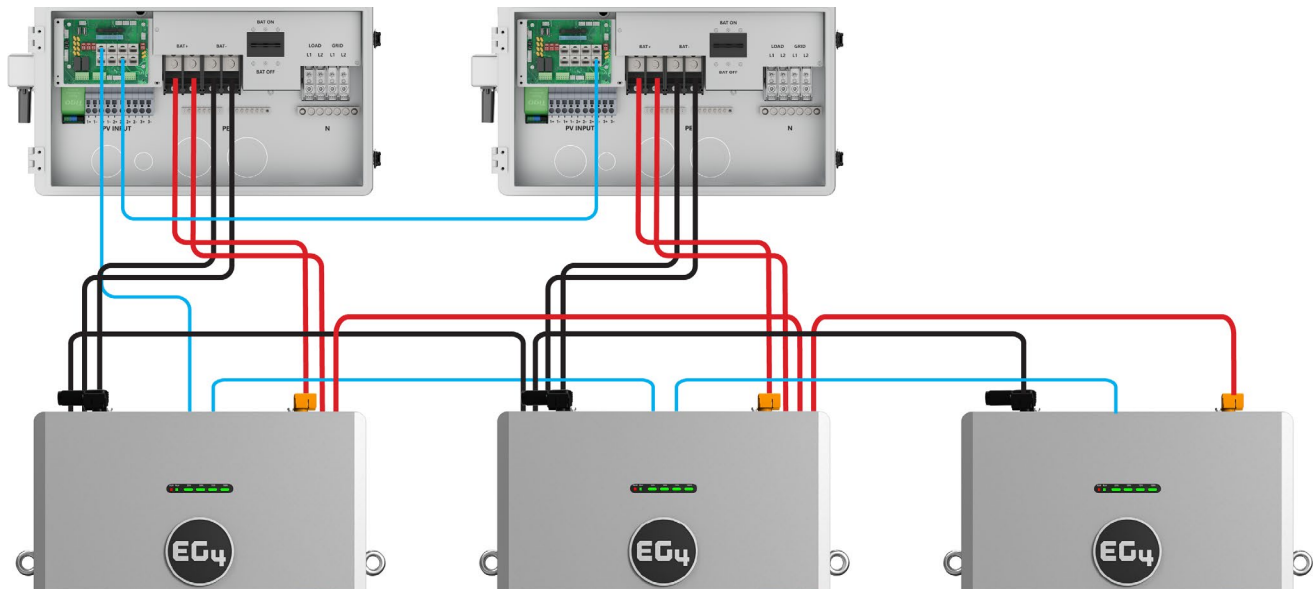

**(2) FlexBOSS21 with (3) 314 All Weather**

*Illustrations for representative purposes only.*

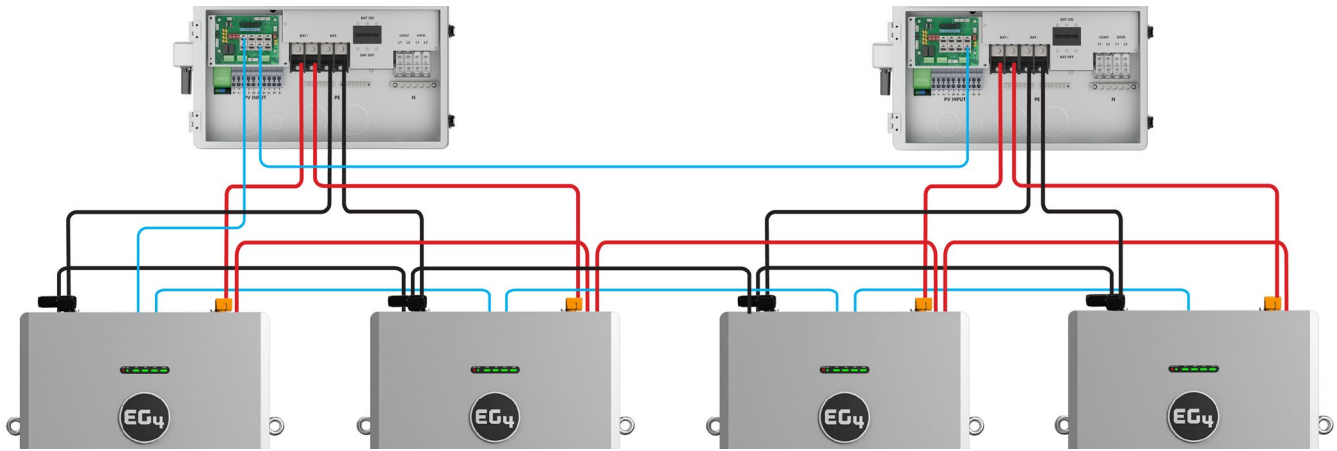

**(2) FlexBOSS21 with (4) 314 All Weather**

### THREE INVERTER CONFIGURATIONS

*Illustrations for representative purposes only.*

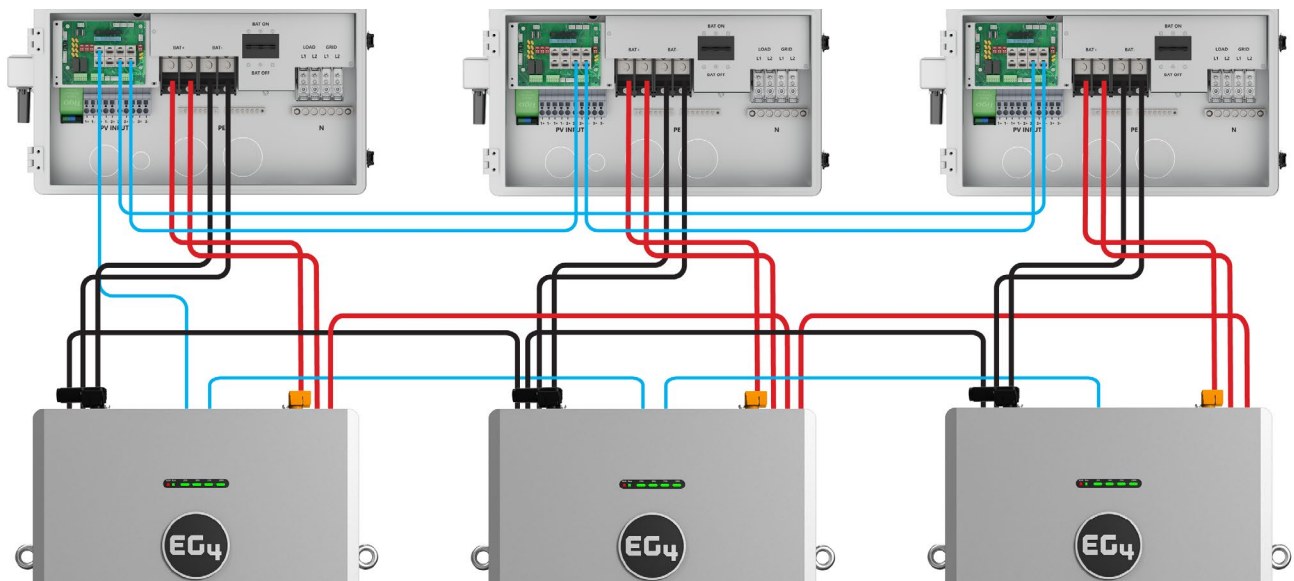

**(3) FlexBOSS21 with (3) 314 All Weather**

*Illustrations for representative purposes only.*

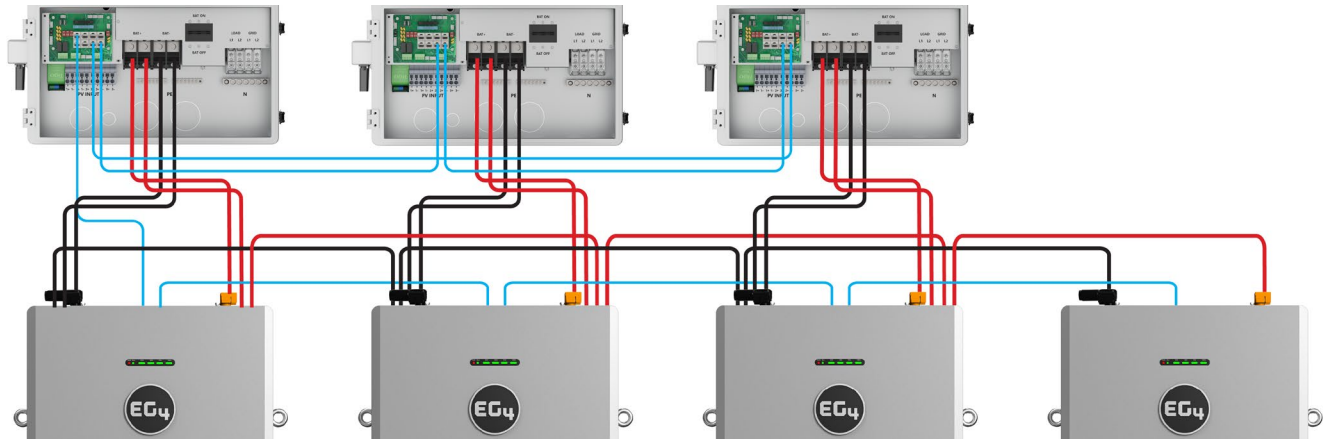

**(3) FlexBOSS21 with (4) 314 All Weather**

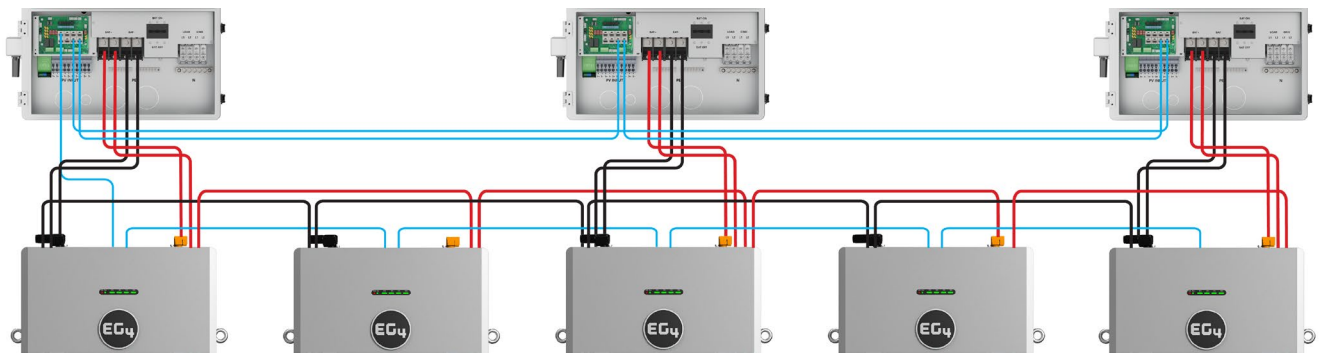

**(3) FlexBOSS21 with (5) 314 All Weather**

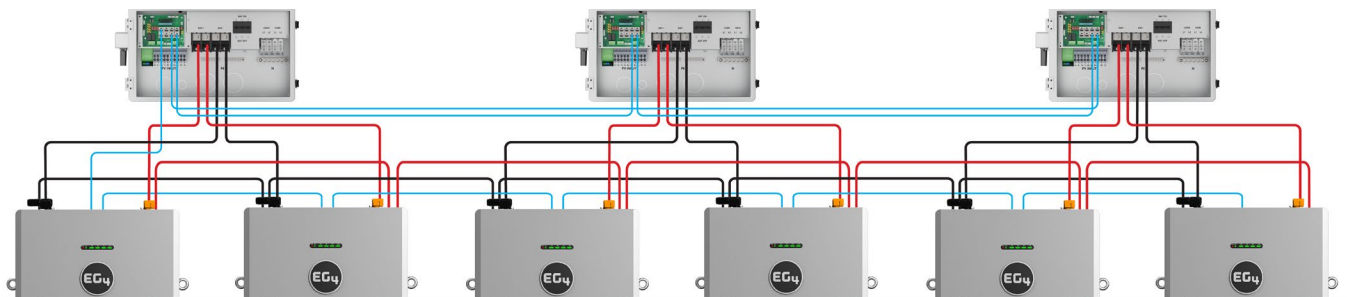

**(3) FlexBOSS21 with (6) 314 All Weather**

## **8. BATTERY COMMUNICATIONS**

Each EG4® battery communicates seamlessly with the inverter, allowing the user to easily monitor and control the system. Advanced communication protocols enable real-time data exchange, providing critical information on battery performance, state of charge, and overall system status

### **8.1 AUTO-ID BMS PROTOCOL FEATURE**

The EG4® WallMount 314Ah All Weather Battery eliminates the need for manual DIP switch configuration and protocol selection. The Auto-ID feature automatically detects the correct inverter communication protocol and assigns unique battery IDs to enable seamless communication in multi-battery systems.

Auto-ID performs two primary functions: protocol detection and battery ID assignment. When the master battery powers on and connects to the system, the BMS scans for inverter communication signals and automatically selects the appropriate protocol. For example, when paired with the EG4 FlexBOSS21 inverter, the BMS automatically selects the EG4/Lux protocol without requiring any user configuration.

At the same time, the system assigns the first battery as ID1 (master). Each additional Auto-ID battery added to the chain automatically receives a unique ID in the correct sequence. As a result, installers no longer need to manually designate a master unit or configure individual batteries, because the BMS manages the entire process internally. The Auto-ID BMS protocol is available only on EG4 batteries that do not include DIP switches. Scan the QR code below for more information about Auto-ID BMS protocol features.



## 8.2 BMS AUTO-ID PROCEDURE



### NOTE:

The 120Ω terminating resistor establishes closed-loop communication between batteries. The inverters listed in Section 9.3 support closed-loop communication with the battery.

1. Place all battery breakers in the parallel battery bank in the OFF position.
2. Verify that all physical connections are secure and correctly installed according to the communication wiring diagrams in Section 8.1.
3. Install a 120Ω terminating resistor in Comm1 on the master battery and in Comm2 on the last battery in the parallel battery bank.
4. Press the BMS On/Off button to power on the master battery. The Auto-ID process begins and typically completes within 3 – 5 seconds as the master battery assigns IDs to the slave batteries.
5. Power on each remaining battery one at a time at approximately 5-second intervals by pressing the BMS On/Off button, starting with the battery immediately after the master and continuing down the chain.
6. Confirm that all batteries have been automatically assigned IDs. Verify that no faults or protection events are active on any battery or inverter after startup.

## 8.3 COMMUNICATION CABLE PINOUT

EG4® batteries interface with an inverter by designating a master battery (ID 1). The Auto-ID feature automatically assigns the first battery connected to the CAN port as the master battery with ID 1. Available battery ID numbers range from 1 – 32. The battery connects directly to the inverter using a CAT 5, CAT 5e, or CAT 6 cable wired to pins 1-5 on the inverter side. For closed-loop CAN bus communication with non-EG4 inverters, refer to the inverter manufacturer’s documentation for compatibility and configuration requirements.

### Communication Cable Pinout & Table\*

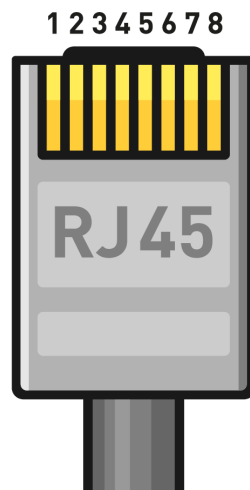

PIN	DESCRIPTION
1	RS485-B
2	RS485-A
3	CAN Ground (optional)
4	CAN High
5	CAN Low

**\*Pinouts are for battery side; please refer to the inverter user manual for pinout configuration on system end.**

## **RS485 COMMUNICATION COMPATIBLE INVERTERS:**

- EG4
- Growatt
- Schneider
- Voltronic

## **CAN COMMUNICATION COMPATIBLE INVERTERS:**

- EG4
- Growatt
- Deye
- Megarevo
- Luxpower
- Victron
- Solis
- SMA

## 9. BATTERY STARTUP AND SHUTDOWN PROCEDURE

The battery includes pre-charge resistors that control the startup sequence and supply power to the inverter. In 51.2 V nominal voltage systems, these pre-charge resistors are essential for limiting inrush current drawn by the inverter during startup.

### 9.1 STARTUP

After completing all physical connections and confirming that the inverter is ready to accept battery power, follow the steps below:

1. Close (turn on) the battery's circuit breaker.
2. Wait approximately 5 seconds, then power on the battery BMS by pressing the power button on the side of the unit.



#### **NOTE:**

When using multiple batteries in parallel, repeat the steps listed above per battery, always starting with the master battery.

### 9.2 SHUTDOWN

1. Power off the battery's BMS by pressing the power button on the side of the unit.
2. Open (turn off) the battery's circuit breaker.



#### **NOTE:**

When using multiple batteries in parallel, repeat the steps above for each battery, starting with the master battery.



## 10. TROUBLESHOOTING, MAINTENANCE & DISPOSAL

### ALARM DESCRIPTION AND TROUBLESHOOTING

When the ALM indicator on the battery control panel illuminates, the battery has triggered an alarm or entered a protective state to prevent potential damage. Identify the cause of the alarm or fault using the app or BMS Tools, and take appropriate corrective action or visit the battery site to troubleshoot as needed.

Battery LED alarms are shown in the tables below:

### 10.1 LED INDICATOR STATUS AND DEFINITION

STATUS	NORMAL/ ALARM/ PROTECTION	RUN	ALM	SOC INDICATOR LED	NOTES
				SOC1~SOC4	-
Shutdown/Sleep		OFF	OFF	OFF	-
Stand-by	Normal	ON	OFF	Based on battery indicator (Each LED indicates 25% SOC)	-
Charge	Normal	Flash 1	OFF		-
	Alarm	Flash 1	Flash 1		-
	End-off Voltage	ON	OFF		-
	Over-Temp Protection	OFF	ON		-
	Over-current Transfer Limit Protection	Flash 1	Flash 3/OFF		Over-current flash 3, limit-current OFF
Discharge	Normal	Flash 2	OFF	Based on SOC indicator	-
	Alarm	Flash 2	Flash 3		-
	End-off Voltage	OFF	OFF		Go to sleep
	Over-Temp/ Over-current Protection	OFF	ON		-

The following bullets further define the values in the table above:

- **SOC:** Every light represents ~25% capacity
- **Shutdown:** All LED lights are off
- **Power on:** RUN light is always on
- **System failure:** ALM light is always on
- **Flash 1:** Flash once every second
- **Flash 2:** Flash once every 1.5 seconds
- **Flash 3:** Flash once every 2 seconds

## WARNING DEFINITIONS AND SOLUTIONS

STATE	TYPE	INDICATOR	SOLUTION
Charge	Over current protection	ALM	Stop charge, check the settings and limitation
	Temperature protection	ALM	Stop charge, wait for the temp to recover
Discharge	Over current protection	ALM	Stop discharge, check if there is an overload
	Temperature protection	ALM	Stop discharge, wait for the temp to recover



### WARNING:

The Historical Record tab shows events that occurred before the module entered a warning or protection state. Export this data as a text (.txt) file to provide the distributor with additional information for troubleshooting assistance.

If any warnings or faults from both tables persist, contact the distributor for additional troubleshooting steps.

## FAULT DEFINITIONS AND SOLUTIONS

NO.	FAULT	ANALYSIS	SOLUTION
1	Inverter communication failure	Check communication port connection, and battery ID setting.	Check communication wiring and restart BMS. See section 7.1 for wiring information.
2	No DC output	Open breaker, or battery voltage is too low.	Close the battery breaker or charge the battery.
3	Power supply unstable	Battery capacity is not at full power.	Check for proper battery cable connection.
4	Battery cannot be fully charged	DC output voltage is below the minimum charge voltage.	Check charging settings on the inverter to ensure they match battery requirements.
5	ALM LED always on	Short circuit	Disconnect the power cable and check all cables.
6	Battery output voltage is unstable	Battery management system is not operating normally.	Press the reset button to reset the battery, then reboot the system.
7	ALM LED flashes 20 times with SOC1 LED on	Unbalanced voltage within a cell.	Deep discharge the battery bank (<20% SOC), then fully charge the battery bank.
8	ALM LED flashes 20 times with SOC2 LED on	Unbalanced temperature.	Double check the temperature of the battery. If the temperature range is good, restart the battery. If the issue persists, contact the distributor.
9	ALM LED flashes 20 times with SOC3/SOC4 LED on	Battery management system is damaged.	Contact the distributor.
10	Different SOC value of batteries in parallel operation	No issue.	Deep discharge the battery bank (<20% SOC), then fully charge the battery bank.
11	Low voltage protection with no LED on	BMS is in low voltage protection and is in sleep mode.	Fully charge and restart the battery. If issue persists, contact the distributor.
12	Deep discharged with no LED on	Battery voltage is too low to start the BMS	Apply low charge to the battery until the BMS is able to start up. If the issue persists, contact the distributor.

## 10.2 MAINTENANCE

ITEM	MAINTENANCE INTERVAL	MAINTENANCE SOLUTION
Power Cables	Every 6 months	<ol style="list-style-type: none"> <li>1. Inspect the power cable for signs of mechanical damage and verify that the terminal insulation sleeves are intact. If you find any damage, power off the battery and perform maintenance or replace the cable.</li> <li>2. Check the power cable for looseness. If the cable shows any looseness, replace it.</li> <li>3. Inspect the system for loose screws. Tighten any loose screws using a Phillips head screwdriver.</li> </ol>
Communication Cables	Every 12 months	<ol style="list-style-type: none"> <li>1. Check that the terminals on the parallel communication cable are securely tightened. If a terminal is loose, retighten it.</li> <li>2. Inspect the communication cable for visible discoloration. If discoloration is present, shut down the battery and replace the communication cable. Refer to Section 8 for additional information.</li> </ol>
System Status	Every 6 months	<ol style="list-style-type: none"> <li>1. Verify that all operating parameters such as system voltage, current, and temperature remain within normal ranges while the system is running.</li> <li>2. Verify that all primary system components, including system switches and contactors, operate correctly.</li> </ol>
Charge & Discharge	Every 6 months	Perform a light load, shallow charge and discharge test to evaluate the battery's SOC and SOH status using the EG4 monitoring site to review the parameters. Limit the depth of discharge and charge/discharge power to no more than 20% of the rated value.

### **10.3 BATTERY END OF LIFE**

The EG4® WallMount 314Ah All Weather Battery delivers a service life of more than 15 years when used as intended, based on no more than one charge-discharge cycle per day. The battery maintains its ability to hold a charge through thousands of cycles. When the battery reaches the end of its service life, consider the following points before disposal or replacement.

Lithium iron phosphate (LFP) batteries qualify as hazardous material and require proper disposal; do not place them in household trash. Many recycling organizations and programs accept these batteries at little to no cost. Because disposal options vary by location, search online for “Lithium Battery Disposal Near Me” to find qualified facilities that can safely recycle LFP batteries.

**Call the facility in advance to confirm that it is open and currently accepting materials.**

If a suitable disposal location is not available, contact EG4 customer service for assistance. Do not discard the battery or dispose of it improperly.

**11. WARRANTY INFORMATION**

To register the warranty for EG4<sup>®</sup> Electronics products, visit <https://eg4electronics.com/warranty/> and select the appropriate product to begin the registration process.

## **12. CHANGELOG**

V1.0.1

- Updated the Product Overview callout image and table to clearly differentiate Degson terminals from stud terminals.
- Updated verbiage for readability.

V1.0

- Document published



# **EG4**

ELECTRONICS

support@eg4electronics.com  
(903) 609-1988  
www.eg4electronics.com