

GridBOSS System Wiring Diagrams

- 1. EG4 GridBOSS Basic Architecture**
- 2. EG4 GridBOSS direct to Utility Meter or Meter-Main**
 - 2a. EG4 GridBOSS direct to Utility Meter or Meter-Main with Notes**
- 3. EG4 GridBOSS With Utility Required Lockable Disconnects and/or PV Production Meter**

1. EG4 GridBOSS Basic Architecture

GridBOSS supports 1, 2, or 3 EG4 18kPV, 12kPV or FlexBOSS21 Hybrid Inverters (1 FlexBOSS shown)

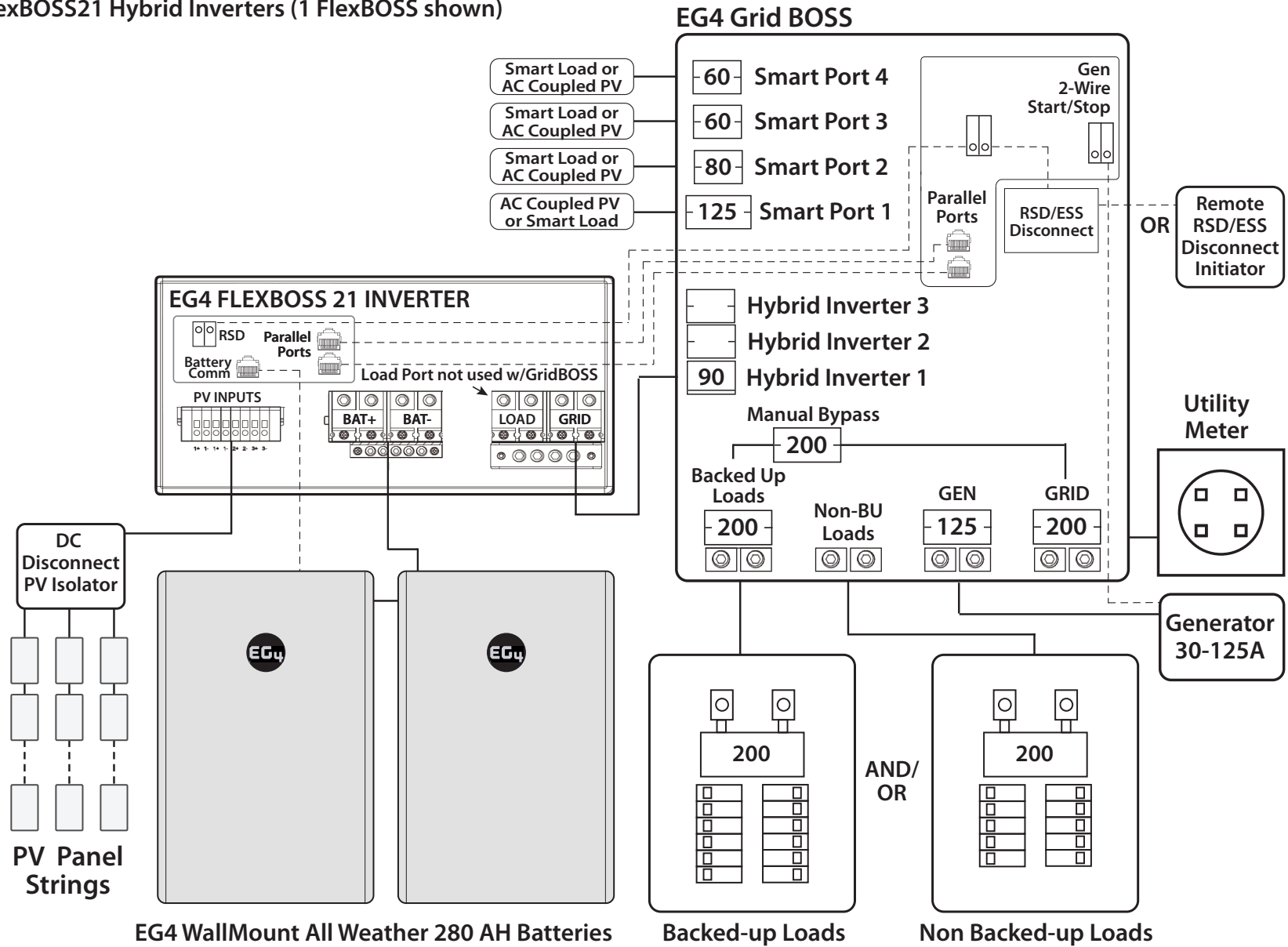

DRAWING #GB-V2-1L-1, VERSION 1.0 ©2024 EG4 ELECTRONICS, LLC. ALL RIGHTS RESERVED.
 THIS DIAGRAM IS FOR ILLUSTRATIVE PURPOSES ONLY. EG4™ IS NOT RESPONSIBLE FOR ACCURACY. FINAL WIRING DIAGRAMS SHOULD BE GENERATED BY A LICENSED PROFESSIONAL AND APPROVED BY ALL AUTHORITIES HAVING JURISDICTION INCLUDING MUNICIPAL, COUNTY, STATE OR ANY OTHER GOVERNMENT OR REGULATORY ENTITY WHICH REGULATES THE USE OF THIS EQUIPMENT WHERE IT MAY BE INSTALLED.

2. EG4 GridBOSS direct to Utility Meter or Meter-Main

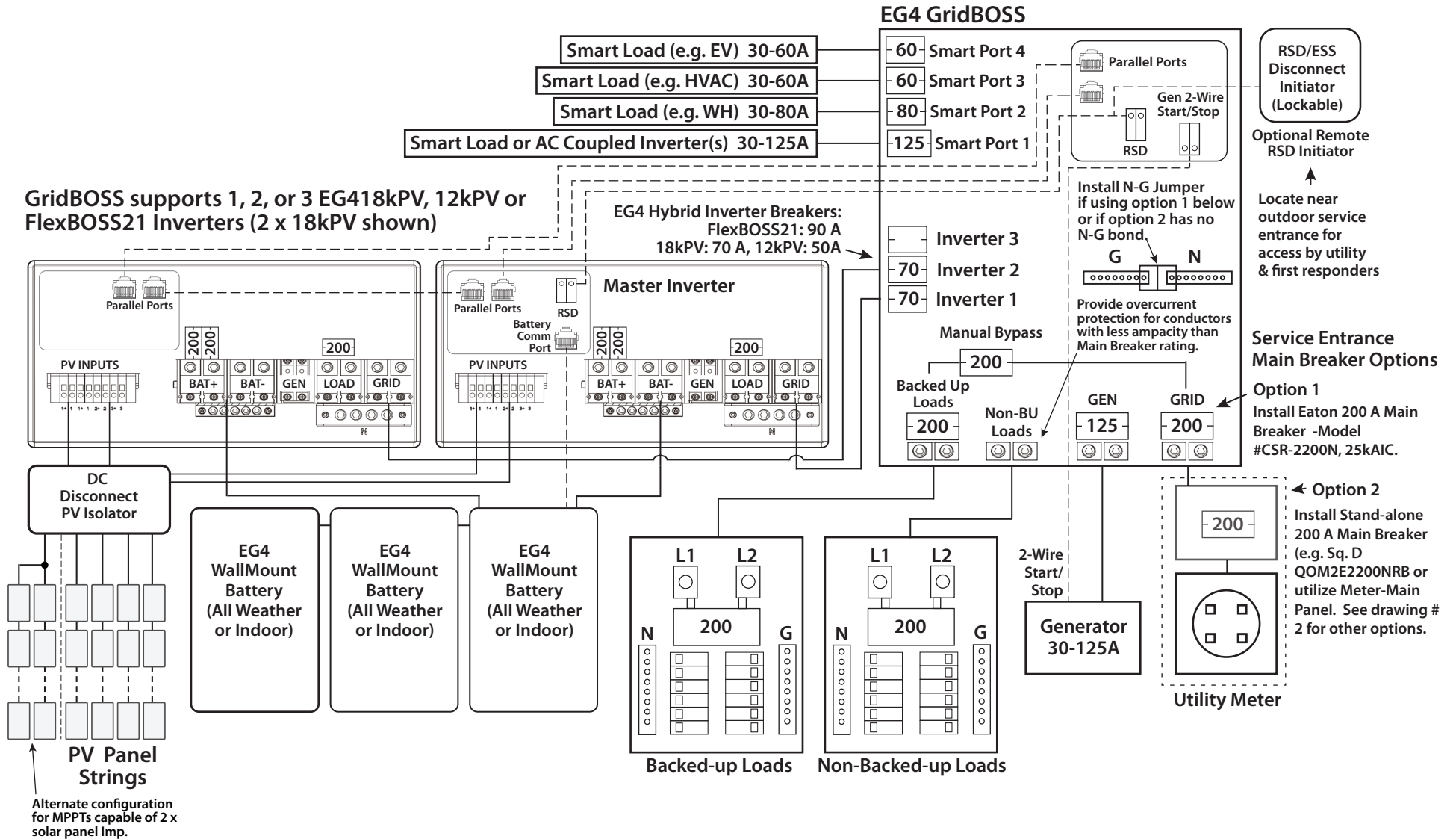

2a. EG4 GridBOSS direct to Utility Meter or Meter-Main with Notes

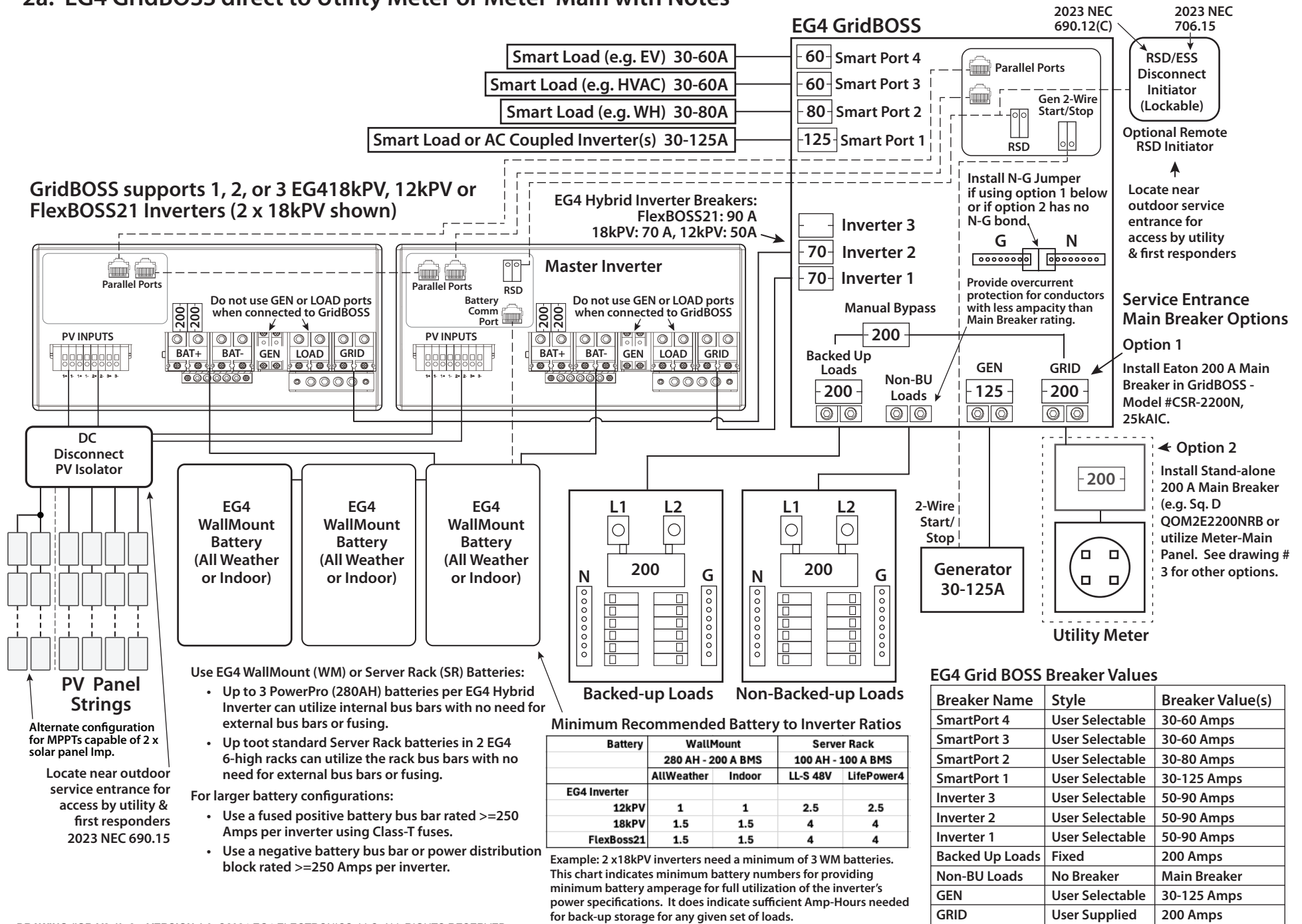

3. EG4 GRIDBOSS with Utility Required Visible Disconnect and/or PV Production Meter

EG4 HYBRID INVERTER
(FlexBOSS21, 18kPV, 12kPV)

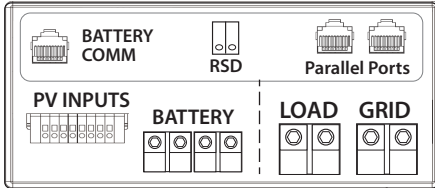

EG4 HYBRID INVERTER
(FlexBOSS21, 18kPV, 12kPV)

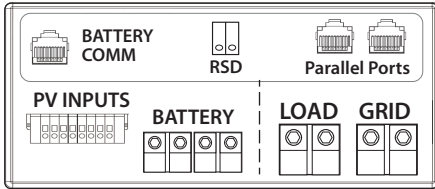

Some AHJs and Utilities will approve using the 3 inverter Hybrid Breakers in the GridBOSS as the PV System Disconnect(s). The GridBOSS door is lockable. In this case you can connect the Inverter's GRID ports directly to the Hybrid Inverter Breakers.

Other Utilities require a Utility Visible Lockable Disconnect and/or a PV Production Meter for the PV Inverter AC Grid-feed circuits. In this case use this configuration or see note below¹

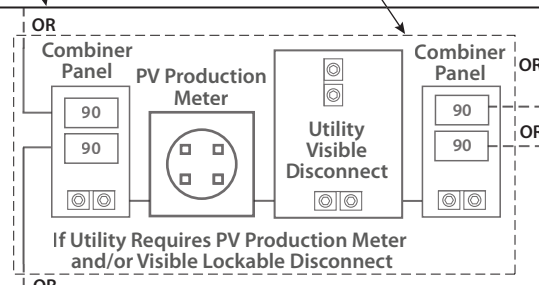

Note: When using 2 x 12kPV Inverters and needing to provide a utility disconnect and/or production meter, a single 90 A breaker can be used at the GridBOSS to feed the utility required circuit. When using 2 18kPV inverters, a single 125 A Breaker will cover that circuit but UL listing of this breaker in this panel is still pending.

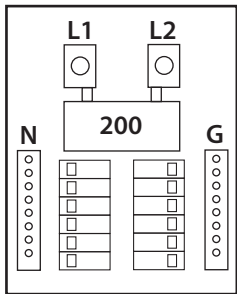

Backed-up Loads

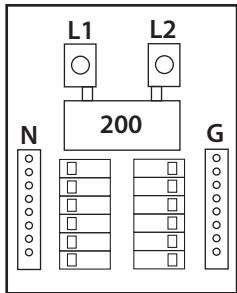

Non-Backed-up Loads

¹ Some Utilities will accept the stand-alone Main or Meter-Main Breaker as also serving the function of the Utility Visible Lockable Disconnect for locking out Grid-Sell back. This has the advantage of not requiring the dedicated disconnect between the Hybrid Inverters and the GridBOSS. The disadvantage is that it disconnects the entire home's service but this disconnect is seldom if ever used. It is only there as a redundant backup safety for the Utility to use if they had a problem on local lines. The Inverter's UL 1741 rating assures they will never produce voltage during an outage. In this case simply label your stand-alone or Meter-Main as the Utility Visible Lockable PV System Disconnect. For utilities that require a PV Production Meter, if the meter is a simply a one-way sell-back meter then it may be possible to put the production meter also in this position.

EG4 Grid BOSS

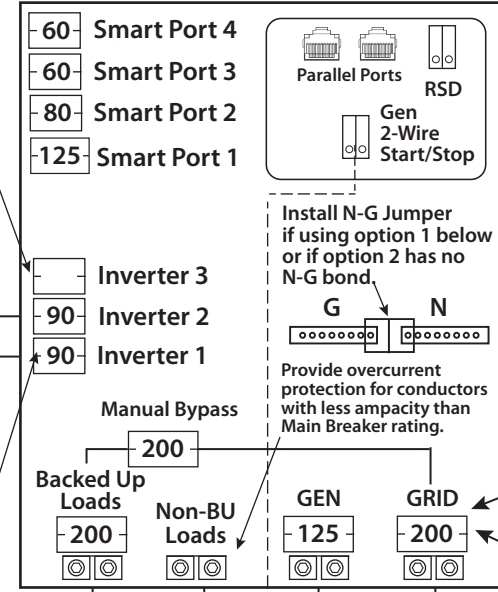

2023 NEC 690.12(C)

2023 NEC 706.15

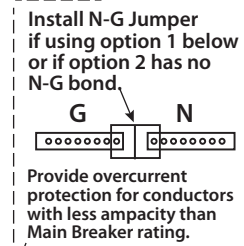
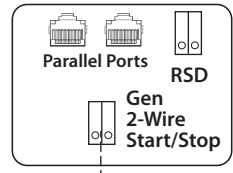
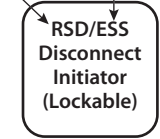

Service Entrance Main Breaker Options

Option 1
Install Eaton 200 A Main Breaker -Model #CSR-2200N, 25kAIC.

Option 2
Install Stand-alone 200 A Main Breaker (e.g. Sq. D QOM2E2200NRB or utilize Meter-Main Panel. See drawing # 3 for other options.

