

EG4[®] BRIGHTMOUNT ADJUSTABLE Cat1

USER MANUAL

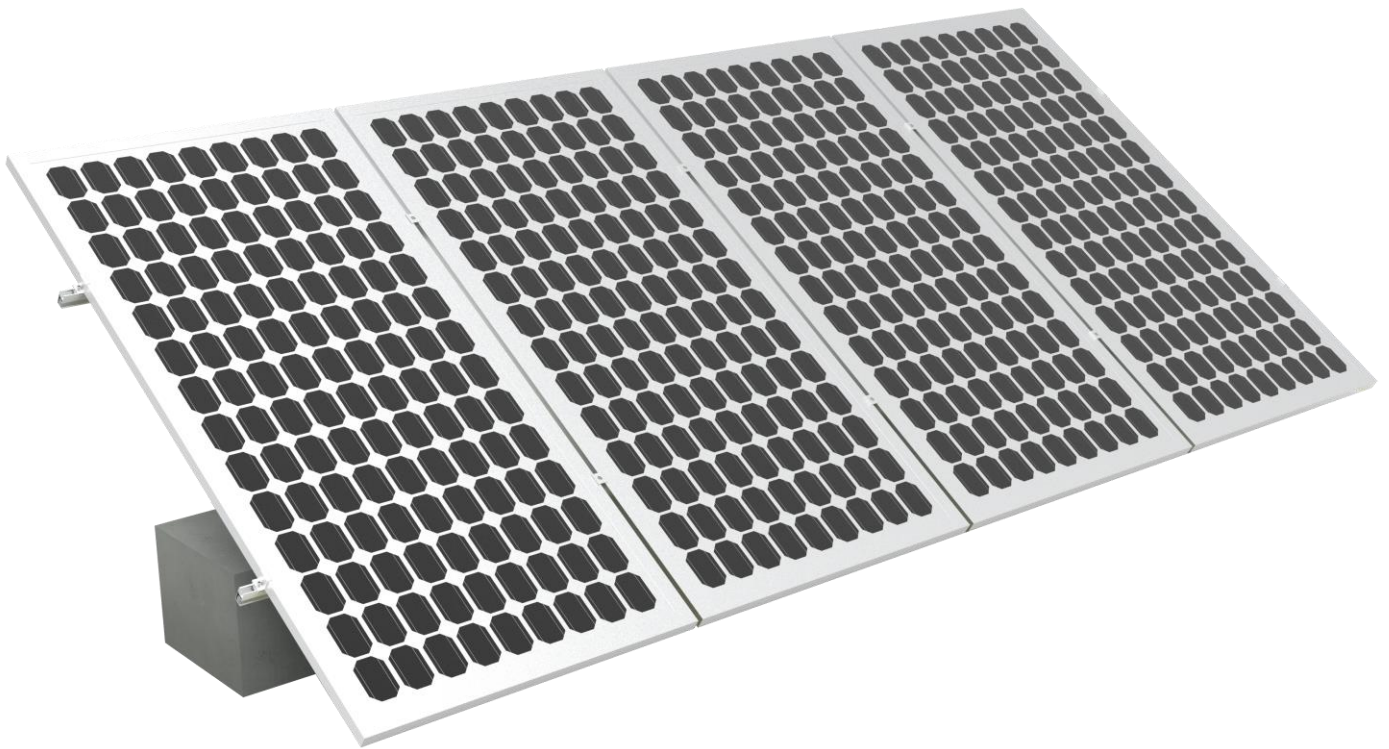

TABLE OF CONTENTS

1.	ABBREVIATIONS.....	1
2.	GENERIC SAFETY.....	2
2.1	SAFETY INSTRUCTIONS.....	2
2.2	IMPORTANT SAFETY NOTIFICATIONS.....	2
3.	INTRODUCTION	4
4.	PACKING LIST.....	4
5.	ENGINEERING DRAWINGS	5
6.	INSTALLATION.....	6
6.1	TOOLS NEEDED	6
7.	INSTALLATION INSTRUCTIONS	6
7.1	INSTALLING CEMENT BLOCKS & BASE	7
7.2	INSTALLATION OF BEAM & COLUMN.....	8
7.3	RACK RAIL ASSEMBLY	11
7.4	SOLAR PANEL INSTALLATION.....	13
7.5	GROUND LUG & WIRE INSTALLATION.....	15
8.	WARRANTY INFORMATION.....	16

1. ABBREVIATIONS

- AWG – American Wire Gauge
- A – Amps
- Ah – Amp hour(s)
- AC – Alternating Current
- AFCI – Arc-Fault Circuit Interrupter
- AHJ – Authority Having Jurisdiction
- kAIC – kilo-Amp Interrupting Capability
- ANSI – American National Standards Institute
- BAT – Battery
- BMS – Battery Management System
- COM – Communication
- CT – Current Transformer
- DC – Direct Current
- DIP – Dual In-line Package
- DOD – Depth of Discharge
- EG – Equipment Ground
- EGS – Equipment Grounding System
- EMC – Electromagnetic Compatibility
- EPS – Emergency Power System
- ESS – Energy Storage System
- E-Stop – Emergency Stop
- FCC – Federal Communication Commission
- GE – Grounding Electrode
- GEC – Grounding Electrode Conductor
- GFCI – Ground Fault Circuit Interrupter
- GFDI – Ground Fault Detector/Interrupter
- Imp – Maximum Power Point Current
- IEEE – Institute of Electrical and Electronic Engineers
- IP – Ingress Protection
- I_{sc} – Short-Circuit Current
- In-lbs. – Inch Pounds
- kW – Kilowatt
- kWh – Kilowatt-hour
- LCD – Liquid Crystal Display
- LFP – Lithium Iron Phosphate
- L1 – Line 1
- L2 – Line 2
- mm – Millimeters
- MPPT – Maximum Power Point Tracking
- mV – Millivolt
- N – Neutral
- NEC – National Electric Code
- NEMA – National Electrical Manufacturers Association
- NFPA – National Fire Prevention Association
- Nm – Newton Meters
- NOCT – Normal Operating Cell Temperature
- PC – Personal Computer
- PCB – Printed Circuit Board
- PE – Protective Earth
- PPE – Personal Protective Equipment
- PV – Photovoltaic
- RSD – Rapid Shut Down
- SCC – Standards Council of Canada
- SOC – State of Charge
- STC – Standard Testing Conditions
- UL – Underwriters Laboratories
- UPS – Uninterrupted Power Supply
- V – Volts
- VOC – Open-Circuit Voltage
- VMP – Voltage Maximum Power

2. GENERIC SAFETY

2.1 SAFETY INSTRUCTIONS

Before beginning any work, carefully read all safety instructions, and always observe them when working on the system. The installation must follow all applicable national or local standards and regulations.

Incorrect installation may cause:

- Injury or death to the installer, operator or third party
- Damage to the equipment

2.2 IMPORTANT SAFETY NOTIFICATIONS



DANGER: *Hazardous Voltage Circuits!*

There are various safety concerns that must be carefully observed before, during, and after the installation, as well as during future operation and maintenance. The following are important safety notifications for the installer and any end users of this product under normal operating conditions.

1. **Personal Protective Equipment (PPE):** Always wear appropriate PPE, including, but not limited to, gloves, safety goggles, hearing protection, and dust masks as needed, to protect from injury.
2. **Hazard.** Risk of back injury or strains from improper lifting techniques. Always lift with your legs, not your back and do not exceed personal lifting capabilities.
3. **Team Lifting:** For bags of concrete, system components, and solar panel placement, always use team lifting approach. Do not attempt to lift heavy objects alone.
4. **Clear Path:** Ensure the path is clear of obstacles before moving. Look for uneven surfaces or debris that could cause trips or falls.
5. **Avoid Loose Clothing:** Do not wear loose clothing or jewelry and ensure long hair is properly contained as not to become caught in drill or other moving parts.
6. **Pinch Point Hazard:** Always be aware of structural pinch points where fingers, hands, or other body parts can become pinched or trapped.
7. **Electrical Safety:** Always assume that all wires are live. Solar panels exposed to sunlight will produce electrical shock. Follow all manufacturers safety requirements when wiring panels.
8. Before installing, operating, or maintaining the system, it is important to inspect all components to ensure they meet the appropriate specifications and conditions for use.



WARNING: TO REDUCE THE RISK OF INJURY, READ ALL INSTRUCTIONS!

All work on this product (system design, installation, operation, setting, configuration, and maintenance) must be carried out by qualified personnel. To reduce the risk of electric shock, do not perform any servicing other than those specified in the operating instructions unless qualified to do so.

1. Read the Manual: Always read and understand this manual and manuals for any third party tools or products used in the construction or use of this racking system. Please pay strict attention to each manufacturer's safety warnings.
2. This manual is not intended to instruct the end user on solar panel wiring and safety protocol, please see solar panel manufacturer's installation procedures and safety requirements.
3. For electrical work, follow all local and national wiring standards and regulations.
4. Make sure the system is properly grounded. All wiring should be in accordance with the National Electrical Code (NEC), ANSI/NFPA 70.
5. General Child Safety Warnings:
 - a. Choking Hazard: Ensure small parts are kept out of reach of children.
 - b. Avoid Climbing: Warn children against climbing or playing on racking system. This can lead to falls and injuries.
 - c. Ensure all wiring is secure and out of reach of children. Do not allow children access to electrical components.



WARNING!

Cancer and Reproductive Harm – See www.P65Warnings.ca.gov for more details.

DISCLAIMER

EG4 reserves the right to make changes to the material herein at any time without notice. Please refer to www.eg4electronics.com for the most updated version of our manuals/spec sheets.

3. INTRODUCTION

The EG4[®] BrightMount Adjustable Cat1 is an innovative, heavy duty solar ground mount system designed specifically for ground mounted solar panel arrays. Manufactured from anodized aluminum alloy with stainless-steel hardware, this ground mount system is designed for the rigors of outdoor use. Each BrightMount kit comes with everything needed to install up to 4 solar panels side-by-side. Five preset angles allow for easy adjustment to get the most out of the system.

4. PACKING LIST

The following items are included with the BrightMount Adjustable Cat1. Before assembly and installation, please inspect the contents to ensure no components were damaged in transit.



Expansion Bolt (×16)

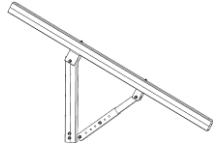

Bracing Rail (×4)



Rail Clamp (×8)

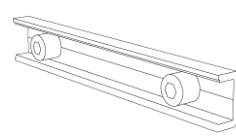

Rail Connector (×2)

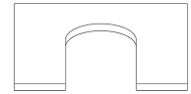

Grounding Plate (×8)

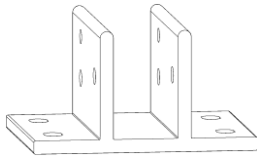

Bracing Rail Bases (×4)

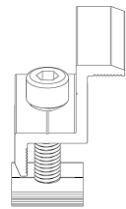

35mm End Clamp (×4)

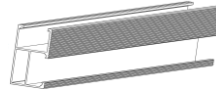

Rail (×4)

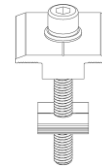

Mid Clamp (×6)

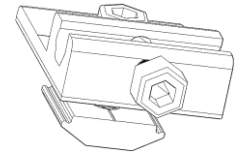

Grounding Lug (×2)

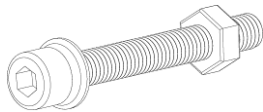

M8*50 (×4)



M8*60 (×12)

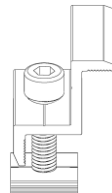

30mm End Clamp (×4)

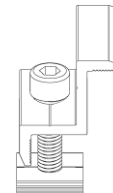

40mm End Clamp (×4)



Bonding Jumper (×2)

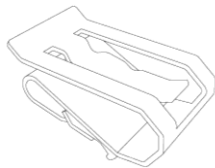

Cable Clip (×2)

Sold Separately

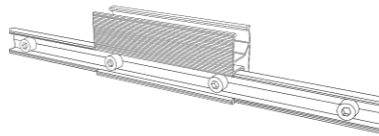

Rail Extension

Note: If the 4 panels width exceeds 173.2 in. (4399.3 mm), the end user can purchase the rail extension kit to accommodate the extra space required.

5. ENGINEERING DRAWINGS

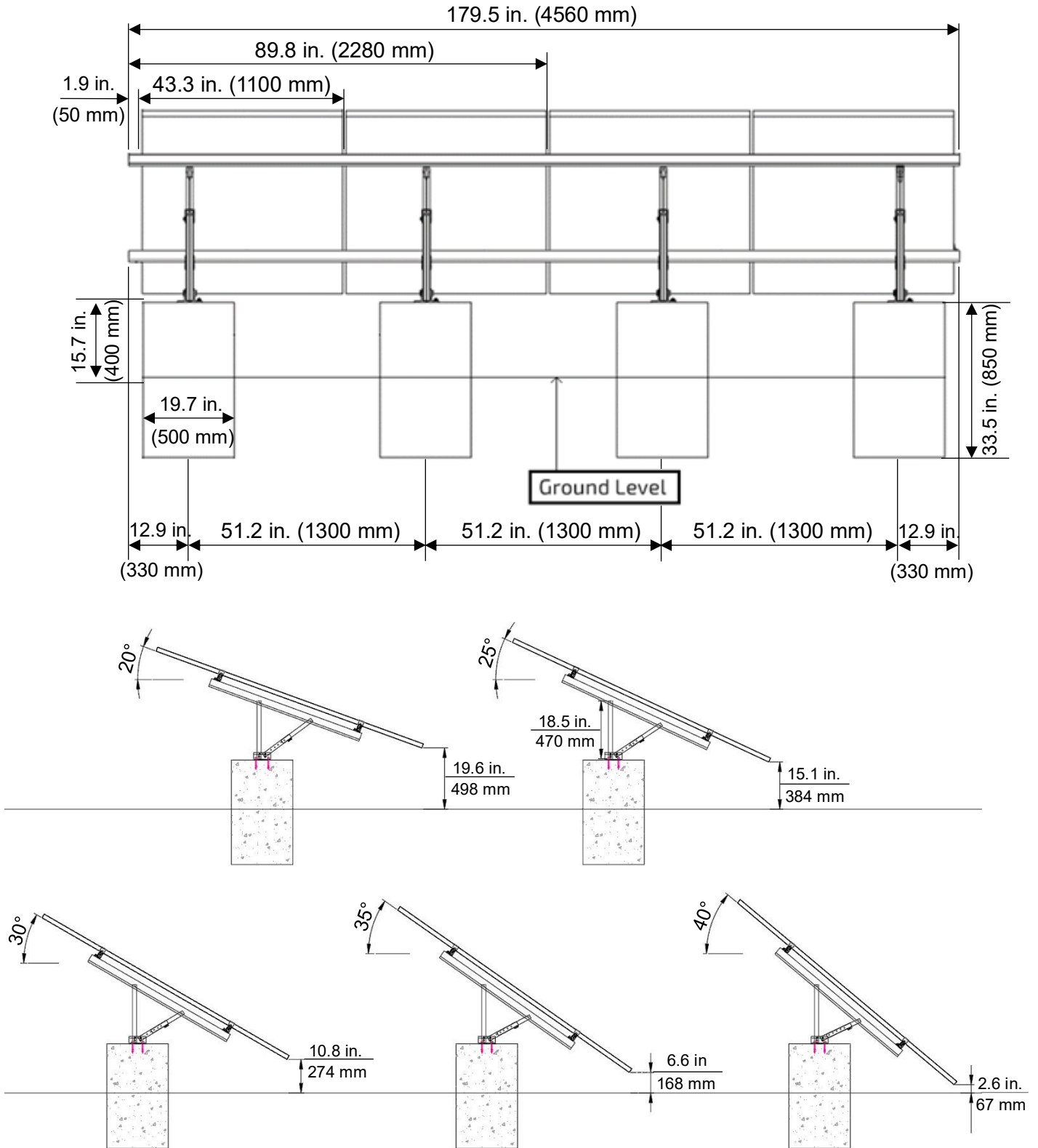

6. INSTALLATION

6.1 TOOLS NEEDED

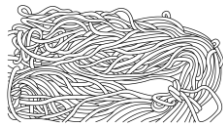

String



Electric Drill

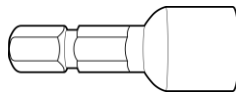

Hexagon Sleeve
M8/M10



Drill Bit 9mm

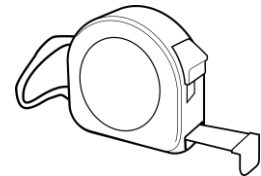

Tape Measure

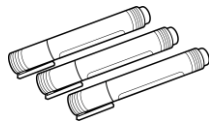

Marking Pen

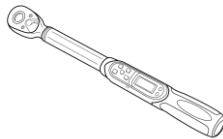

Torque Wrench

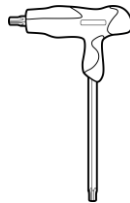

Allen Wrench
#6



Crescent Wrench



Rubber Hammer

7. INSTALLATION INSTRUCTIONS

Before installation, the list below shows a few precautionary measures to prevent nuts and bolts from getting corroded and seizing over time.

1. Reduction of friction:

- Make sure the thread surface is clean; no ash, dirt, etc.
- It is recommended to use wax or lubricant on the surface of bolts when installing.

2. Correct operation:

- When installing the screws, ensure they are perpendicular to the axis of the thread. Do not tilt.
- During the tightening process the force must be uniform, and the tightening torque should not exceed the specified safety torque value.
- Use a torque wrench whenever possible. Avoid using an electric drill. If using an electric drill, keep the speed low.
- Avoid using at high-temperatures and refrain from fast rotations to prevent rapid temperature increase that could cause locking and seizing from using an electric drill.

7.1 INSTALLING CEMENT BLOCKS & BASE

Each leg group requires its own concrete base; this solid foundation prevents movement in case of heavy winds.

Step 1: Pour concrete bases for each leg group according to the figure below. The bases should be 51.2 in. (1300 mm) apart, center to center.

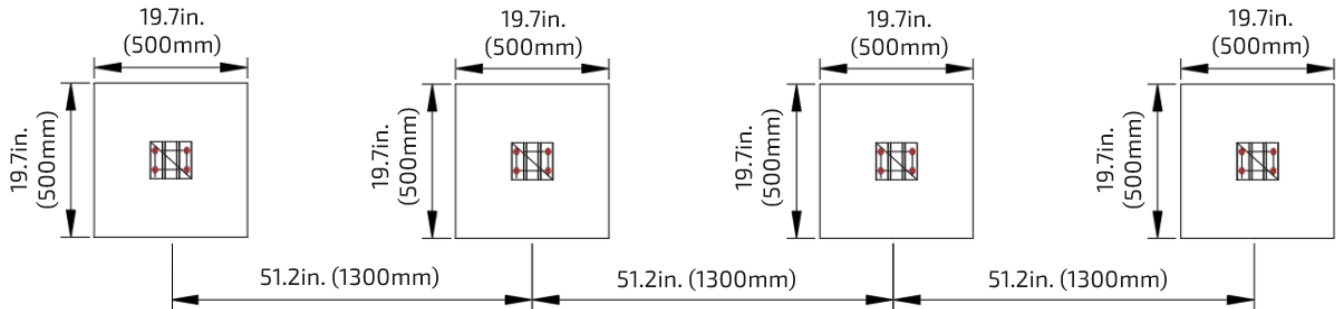

Step 2: The detailed top-down view of a concrete base, shown below, indicates the mounting location, orientation, and dimensions for the leg group main base bracket. After the concrete bases have dried sufficiently, use the main base bracket as a template to mark the correct hole locations on the top of each base. Drill four (4) 0.6 in. (14 mm) diameter by 3 in. (75 mm) deep holes. Install the four (4) M10x100mm concrete expansion bolts into the holes with the flat washer, spring washer, and hex nut.

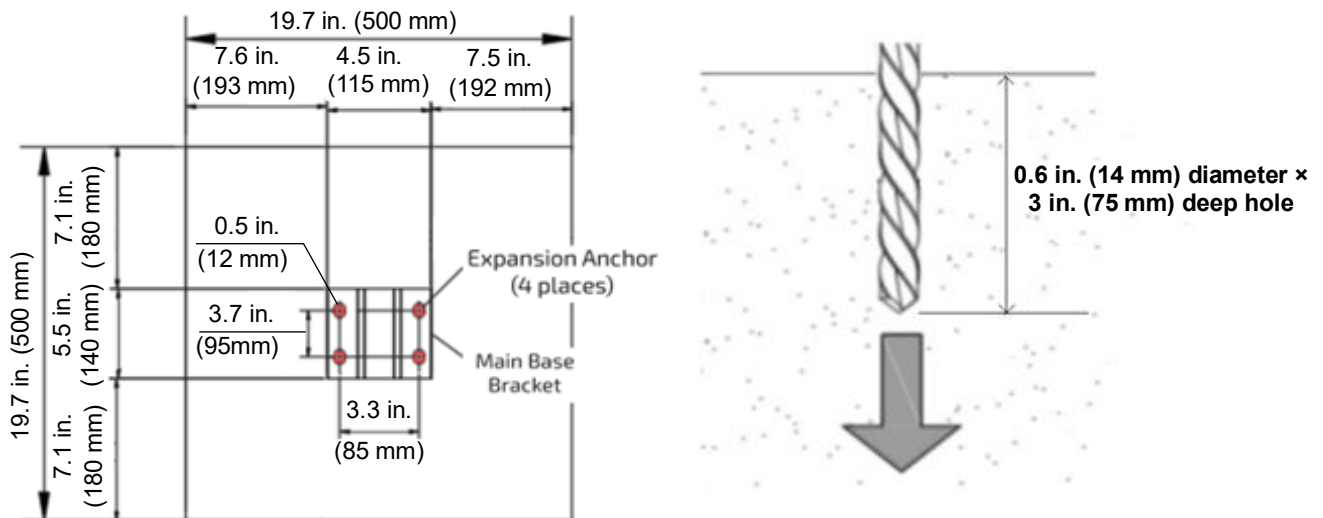

Step 3: Install a leg group on top of each base by placing the main base bracket over the four expansion bolts installed in step 2. Install a flat washer, spring washer, and 17 mm nut on each anchor bolt and torque the 17 mm nuts to 230 in-lbs. (26Nm).
(See images to right & the following page)

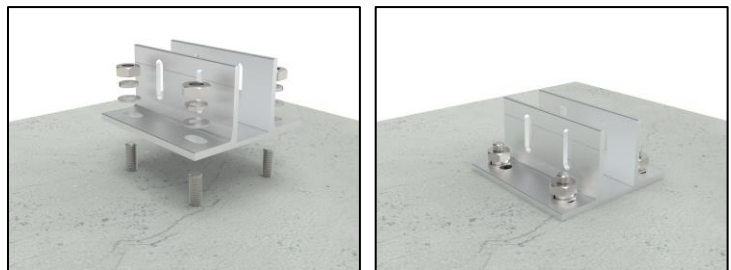

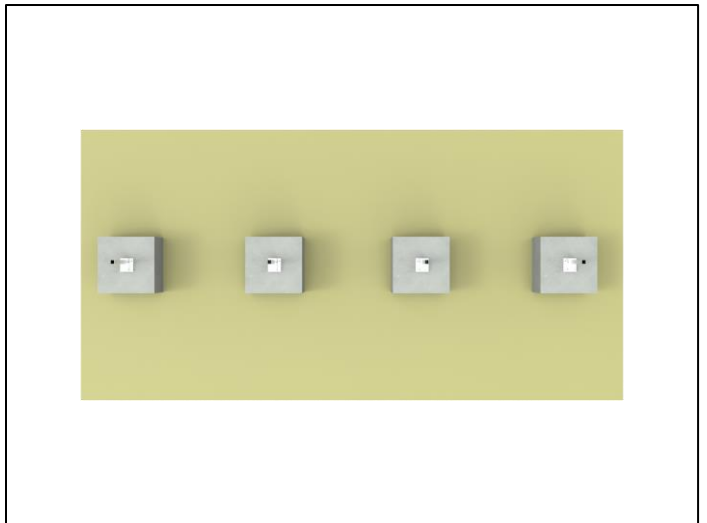
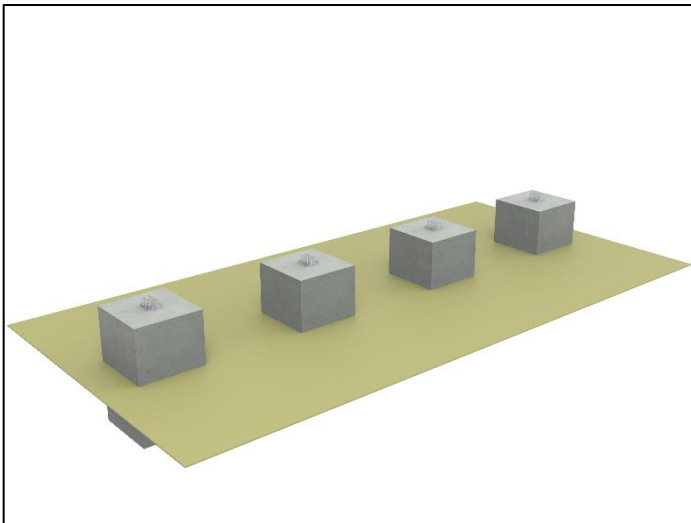

7.2 INSTALLATION OF BEAM & COLUMN

Below are the steps to assemble the leg groups for EG4® BrightMount Adjustable Cat1.

Step 1: Unfold the beam & column leg assembly and align the holes with the base slot holes. Once aligned, install an M8*60 bolt, flat washer, spring washer, and 17 mm nut on each anchor bolt and torque the 17 mm nuts to 115 in-lbs. (13Nm).

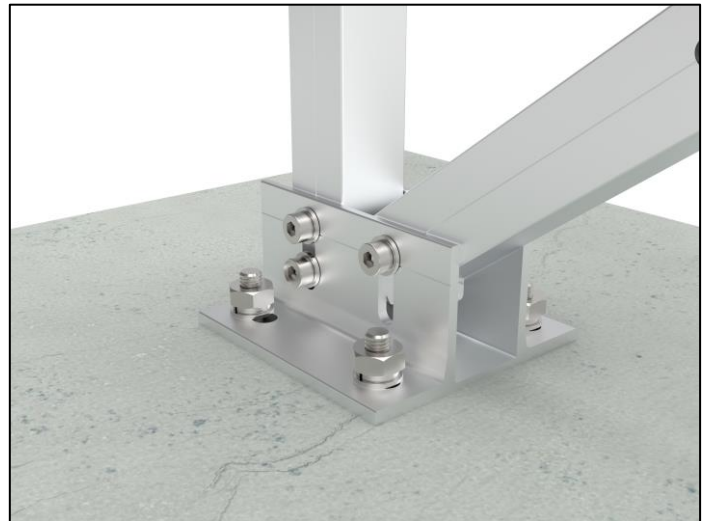
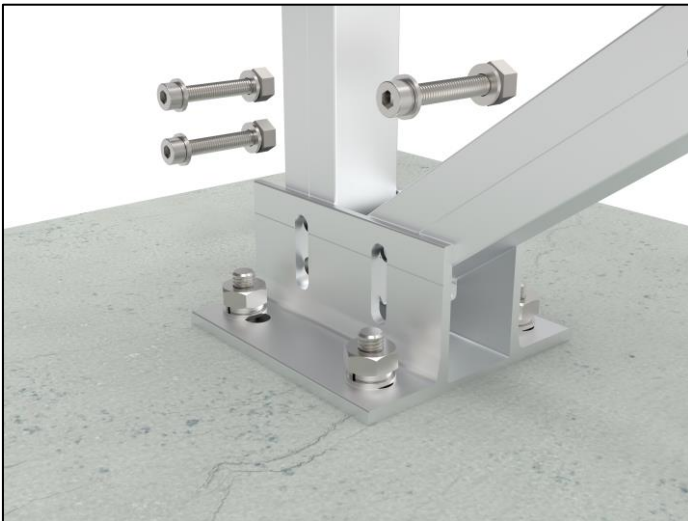

Step 2: Repeat the process four more times.

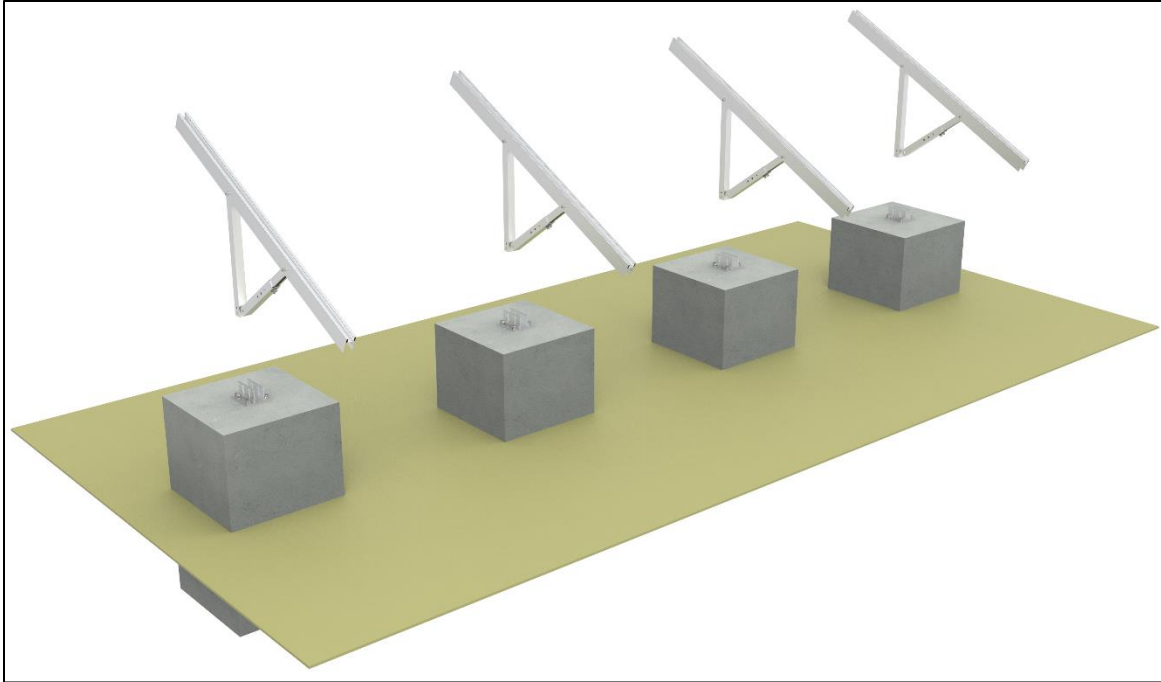

Step 3: The adjustable aluminum leg can be adjusted to create different angles of inclination to maximize solar energy transfer. The inner section of the adjustable leg has one hole while the outer section has five holes. By aligning the hole in the inner section with one of the holes in the outer section, five different fixed angles can be configured (See table and image below).

ANGLE	LENGTH (L)
20°	19.2 in. (487 mm)
25°	17.9 in. (455 mm)
30°	16.6 in. (422 mm)
35°	15.3 in. (388 mm)
40°	13.9 in. (353 mm)

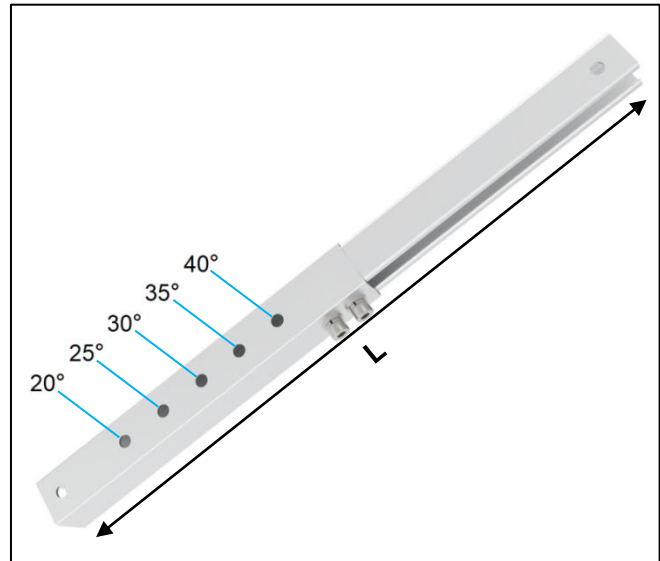

Step 4: After aligning the holes for the desired angle, insert an M8x50 mm bolt with a flat washer through the aligned holes and secure with an M8 flat washer, spring washer, and nut.
(See the images below)

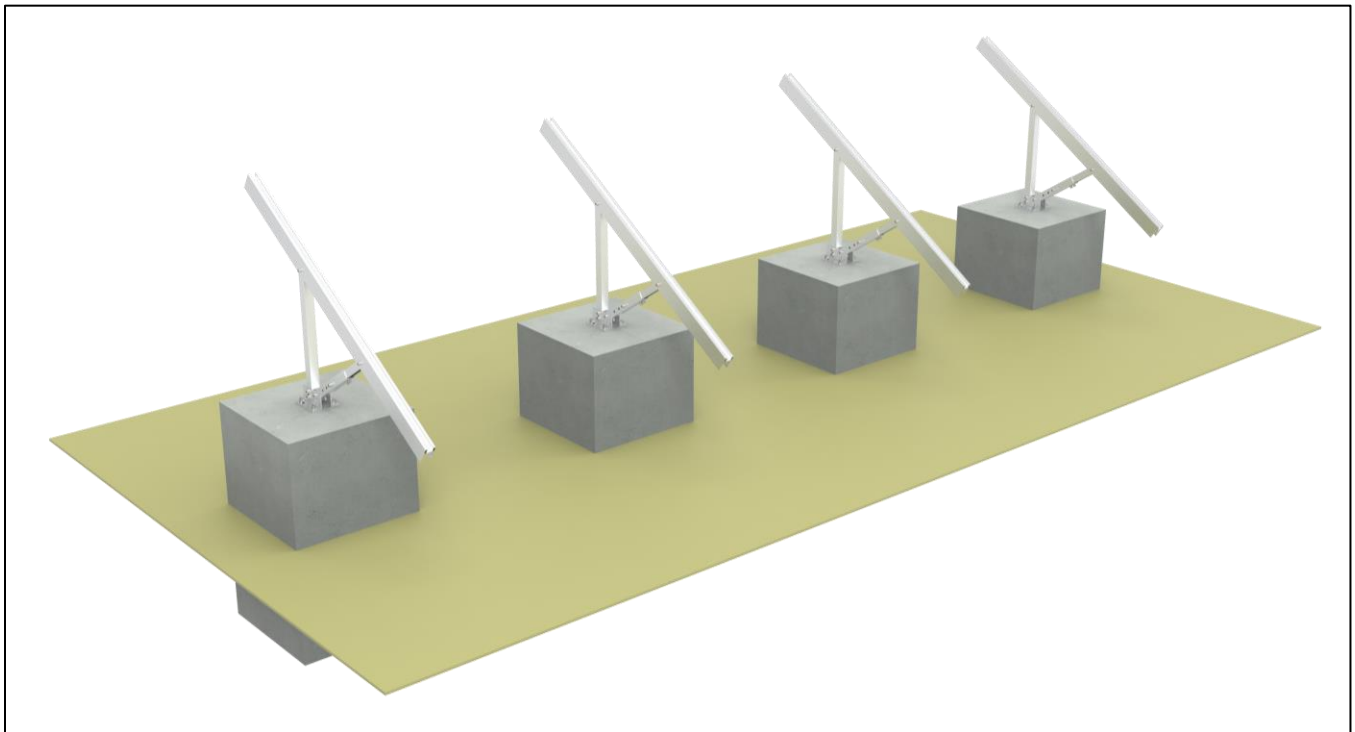
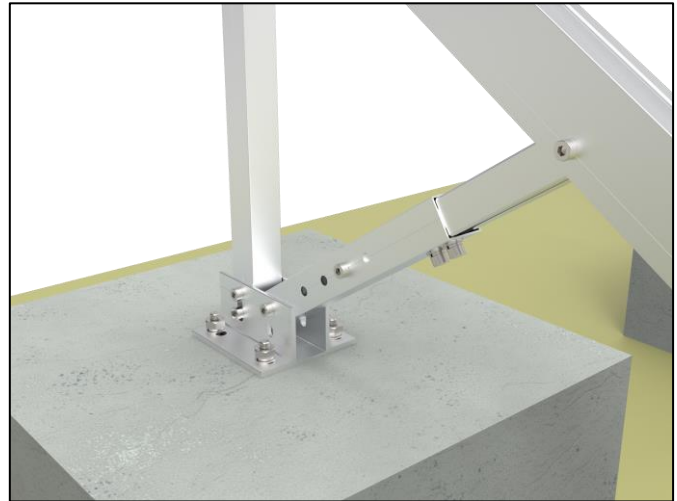
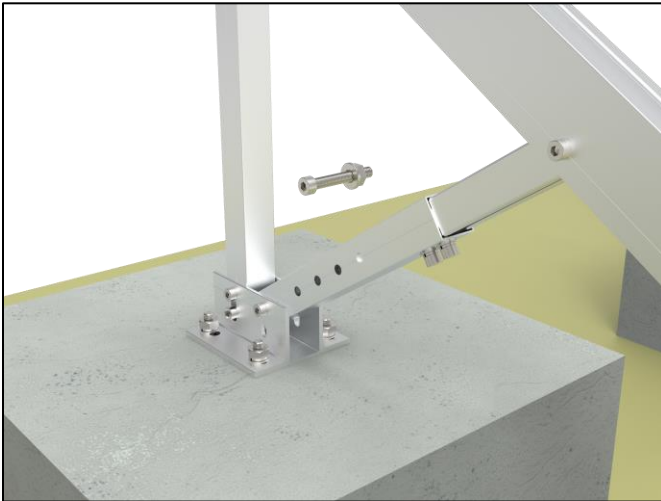

7.3 RACK RAIL ASSEMBLY

The following figures provide instructions on how to install the rail clamps onto the EG4® BrightMount Adjustable Cat1 rack rails and secure them with the set screws.

Step 1: The figure below shows how to connect the rack rails to each other using the splice connector and bonding jumper. It is recommended that a 0.4 in. (10 mm) gap be left between the rack rails to allow for thermal expansion and contraction in the final assembly. Torque all splice connector and bonding jumper fasteners to 79 – 97 in-lbs. (9 – 11Nm).

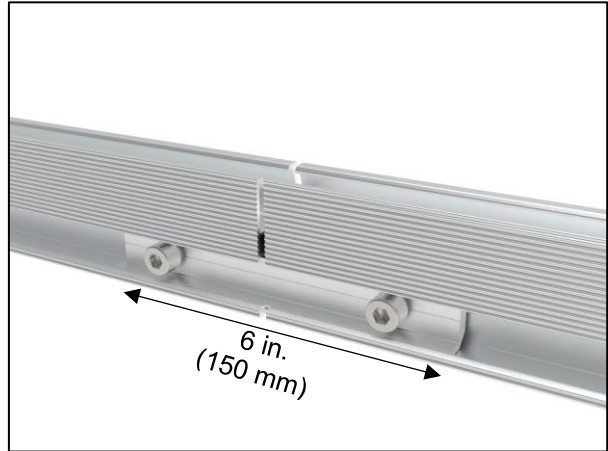
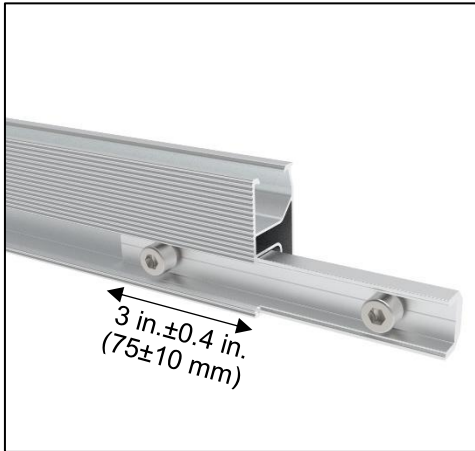

NOTE:

The bolt of the rail connector will pierce the surface of both rails, so proper grounding is achieved. For added assurance, the user can also add the bonding jumper with grounding shim provided. (Shown below)

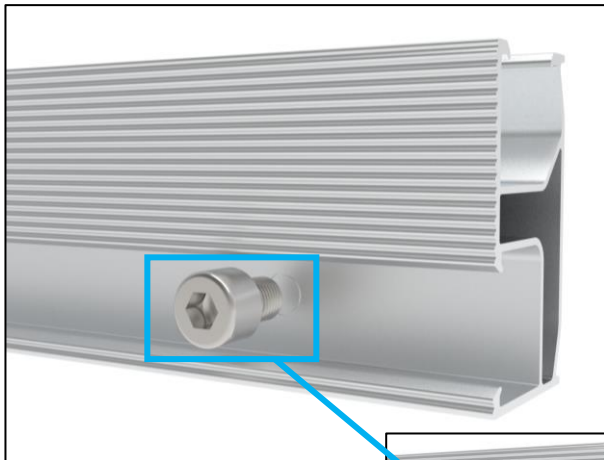

Or

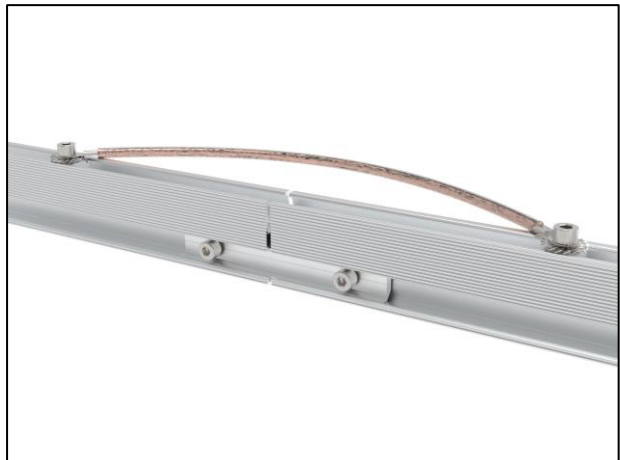



NOTE:

If needing to expand the rail for solar panel's above 43.3 in. (1100 mm), the end user can purchase a rail extension kit to increase the rail's length.

Extension Rail Assembly

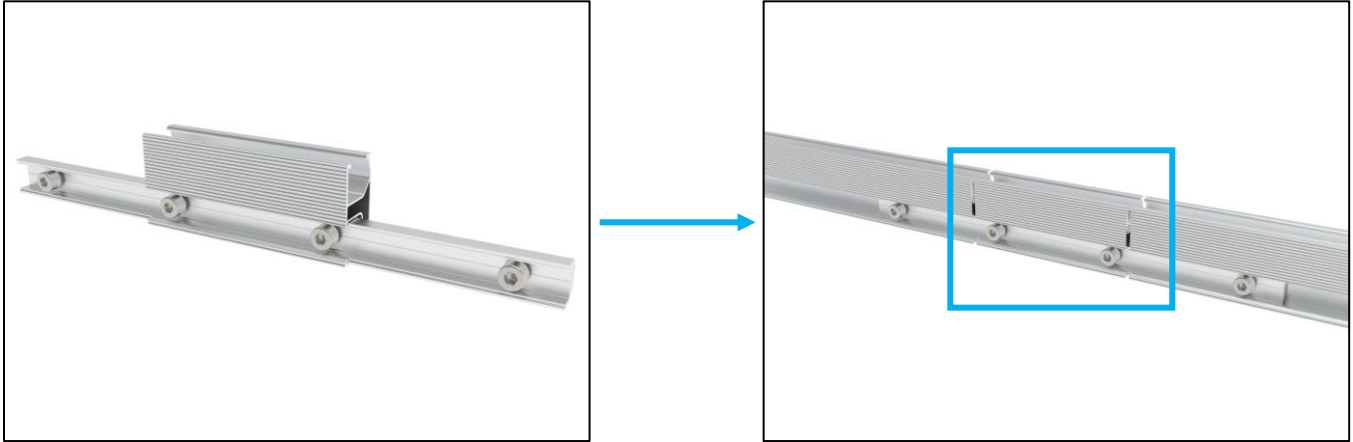

When attaching the extension to the EG4® BrightMount Adjustable Cat1, first remove the original splice connector. Then, insert the extension rail along with the new splice connector in its place. Be sure to maintain a gap of 0.4 in. (10 mm) to accommodate thermal expansion and contraction.

Step 2: Install an “L” bracket on each end of the main beam as shown in the figure below. Secure the “L” brackets to the main beam using an M8x80 mm bolt, a flat washer, a spring washer, and a 13 mm hex nut. Hold the M8x80 mm bolt head with a 6 mm Allen wrench and torque the 13 mm nut to 97 in-lbs. (11Nm).

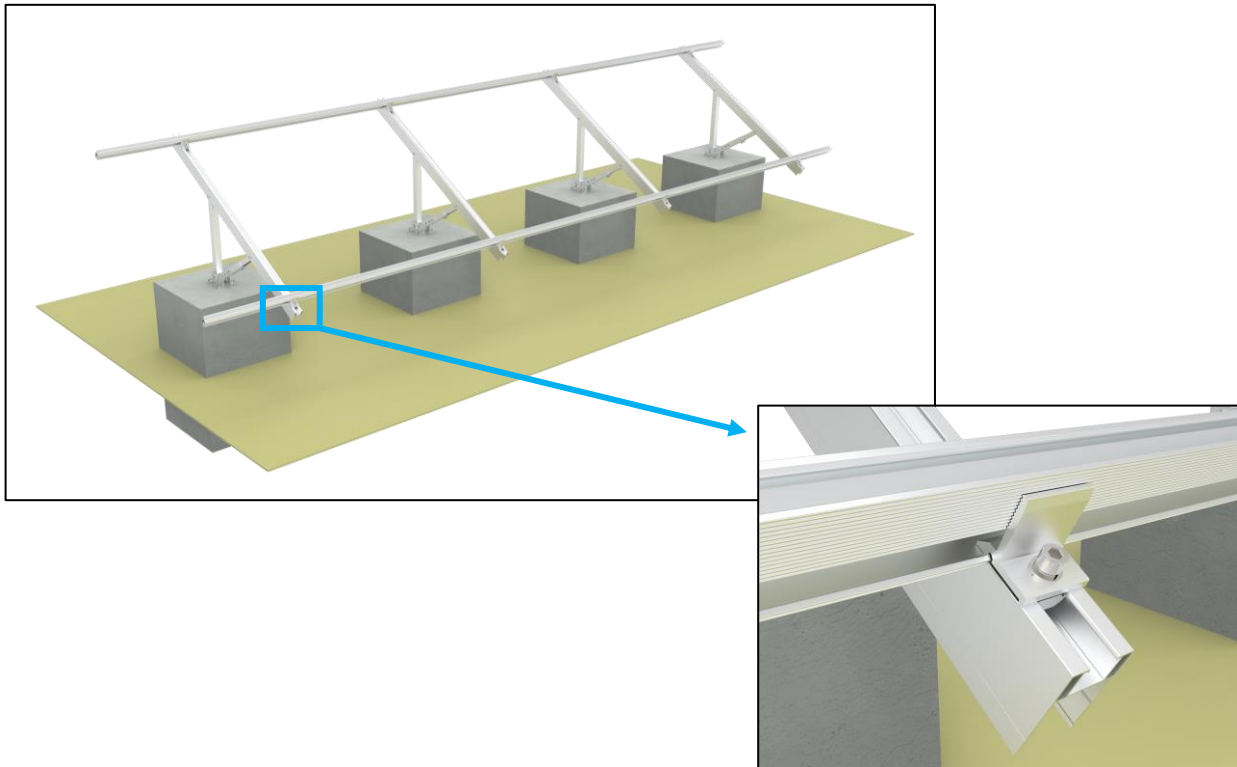

7.4 SOLAR PANEL INSTALLATION



NOTE:

The unit ships with four end clamps each of the following sizes to accommodate varying panel thicknesses: 1.38 in. (35 mm), 1.18 in. (30 mm) and 1.57 in. (40 mm).

The solar panels should be installed in the “portrait” orientation with the top and bottom of each panel extending above and below the top and bottom rack rail, respectively, (i.e. the top and bottom of the panels should overlap the rack rails the same amount so that the panels are approximately centered top-to-bottom on the rack rails).



IMPORTANT:

- These instructions describe solar panel installation with panels in the “portrait” orientation.
- There are three different sized end clamps: 1.18, 1.38, and 1.57 in. (30, 35, and 40 mm). Ensure the end clamps used are properly sized for the solar panels being installed.
- Panels mounted on the ends of the EG4® BrightMount Adjustable Cat1 will require two end clamps and two mid clamps.
- Panels mounted between other panels will require four mid clamps.
- Mid clamps are shared between adjacent panels and can be adjusted to accommodate panel thicknesses of 1.18, 1.38. and 1.57 in. (30, 35, and 40 mm).
- Mid clamps require a grounding clip.
- End clamps do not require a grounding clip.

Step 1: Using the team-lift technique, center the solar panel on the upper and lower rack rails. While the panel is held in place, install two end clamps on the side of the panel as described below.

- a) Referencing the following figure, insert the end clamps into the end of both rack rails.
- b) Push the end clamp against the solar panel so that the top of the end clamp overlaps the top of the solar panel, and the body of the clamp is flush against the side of the solar panel.
- c) Tighten the end clamp fasteners, but do not apply torque until all clamps and panels are installed.

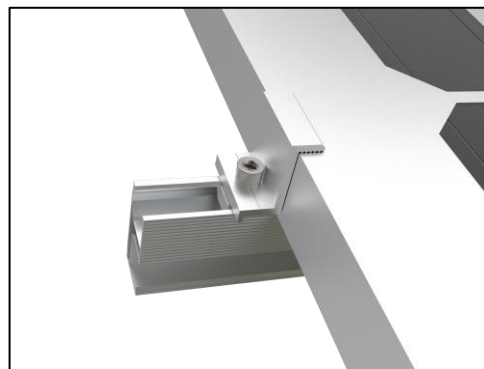
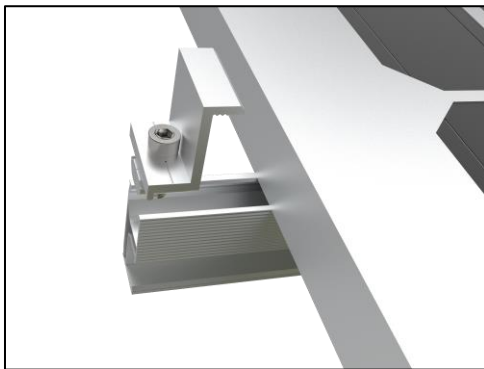

Step 2: Install two mid clamps on the side of the panel as described below.

- a) Referencing the figure below, insert mid clamps with grounding clips onto both rack rails.
- b) Push the mid clamps against the panel so that the mid clamps overlap the top of the panel, and the body of the clamps are flush against the side of the panel. The grounding clip must be between the top of the rack rail and the bottom of the panel for proper grounding.
- c) Mid clamps are shared between adjacent panels. Tighten the mid clamp fasteners to hold the panels in place, but do not torque the mid clamps until all panels are installed.

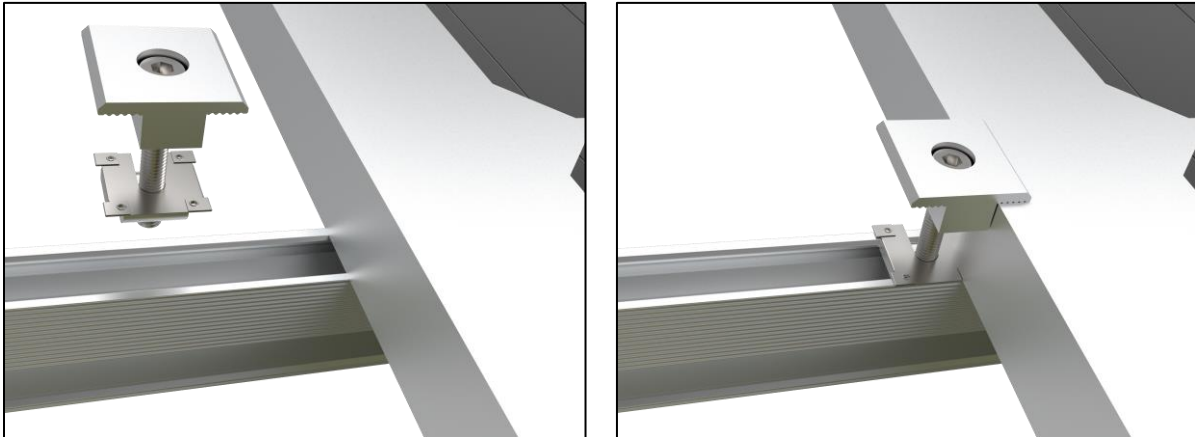

NOTE:

Each mid clamp must have a grounding clip as shown above. Ensure the grounding clips are installed between the bottom of the solar panel and the top of the rack rail. This will ensure proper grounding of all solar panels.



WARNING:

Failure to properly ground the solar panels will adversely impact the operation of the full system.

Step 3: Repeat steps 1 and 2 above for the remaining solar panels. When installing four (4) solar panels, the left-most and right-most panels will require two (2) end clamps and two (2) mid clamps. The middle panels will require four (4) mid clamps, with mid clamps being shared between adjacent panels.

Step 4: After installing all solar panels, make any final adjustments to the panel positions and torque all end clamps and mid clamps to 97 in-lbs. (11Nm). Image below is of the final assembly.

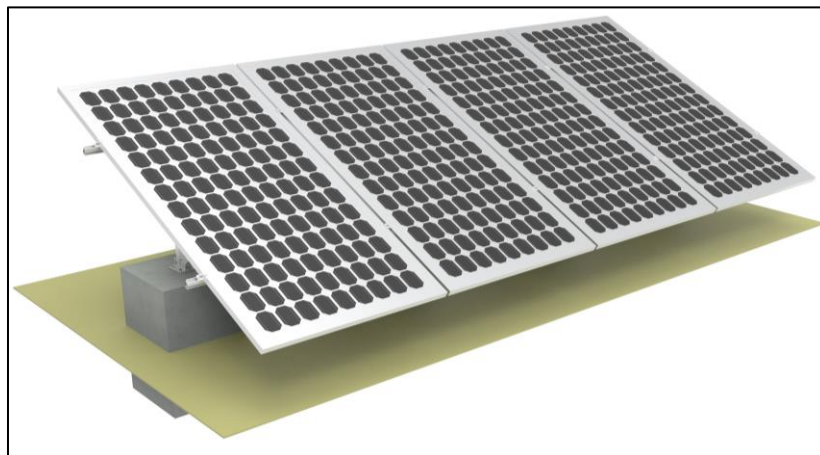

7.5 GROUND LUG & WIRE INSTALLATION

Install grounding lugs on the end of the top and bottom rack rails as described below:

1. Referencing the figure below, align grounding lugs with the end of both rack rails.
2. Install grounding lugs at the end of both rack rails and ensure the ground clips are between the bottom of the ground lugs and the top of the rack rails. Torque the fasteners to 97 in-lbs. (11Nm).

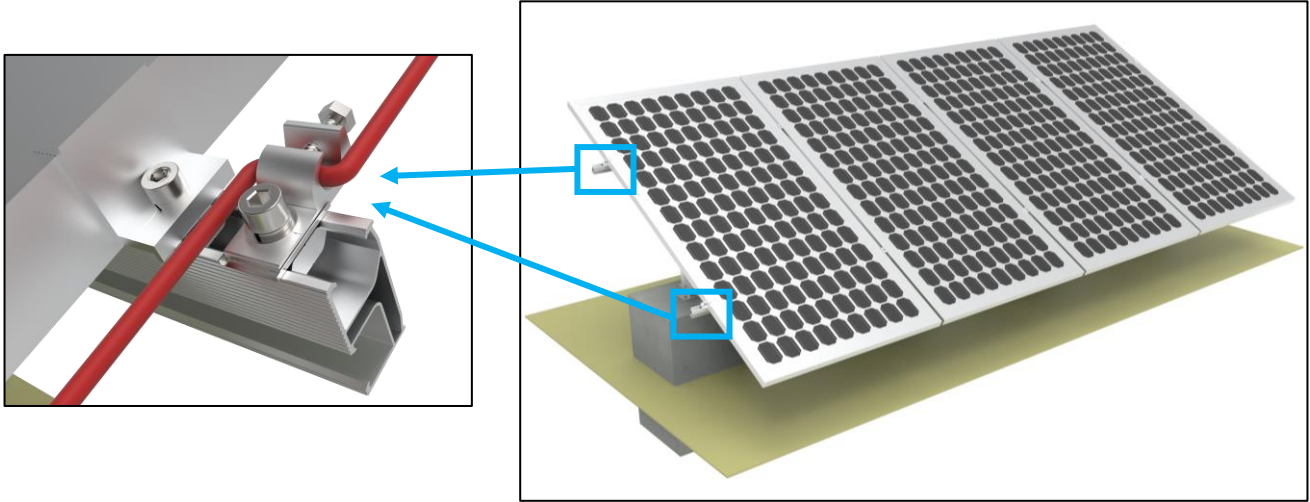

NOTE:

As shown in the image above, it is highly recommended that both the top and bottom rack rails be grounded to earth using grounding lugs.

3. After installing a grounding lug on the end of both rack rails, use a properly gauged ground wire (e.g. 6 – 4 AWG) to connect the rack rails to ground.



NOTE:

Each grounding lug must have a grounding plate. Ensure the grounding plates are installed between the bottom of the grounding lug and the top of the rack rail. This will ensure proper grounding of all solar panels.

4. Finish assembling the EG4® BrightMount Adjustable Cat1 by using the cable clips provided to clean up the cables and secure them to the frame.

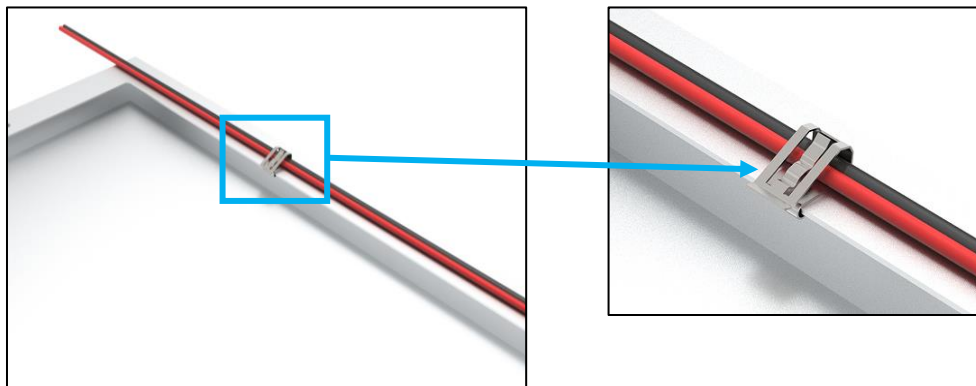

8. WARRANTY INFORMATION

For information regarding warranty registration on EG4® Electronics products, please navigate to <https://eg4electronics.com/warranty/> and select the corresponding product to begin the registration process.



CONTACT US

support@eg4electronics.com

(903) 609-1988

www.eg4electronics.com