

Test Report TR-PR182529 461G, Rev. 1
MIL-STD-461G Testing of the
Inverter 18kPV-12LV, PN: OD00.0000601, and SN: 3464660269
Rack Mount Lithium Battery SN: 1001511066-V4
Power Pro Wall Mount, PN: WP-16/280-1 AWLL, SN: SC2023113739

Prepared For: EG4 Electronics LLC
1130 Como St S
Sulphur Springs, TX 75482
PO: POEG40233

Prepared By: Element Materials Technology Dallas Dallas-Plano West
A.K.A. NTS Labs, LLC.
1701 E. Plano Pkwy. Ste. 150
Plano, TX 75074
(972) 509-2566
nts.com

Issued: 09/05/2024

“These items are controlled by the U.S. Government and authorized for export only to the country of ultimate destination for use by the ultimate consignee or end-user(s) herein identified. They may not be resold, transferred, or otherwise disposed of, to any other country or to any person other than the authorized ultimate consignee or end-user(s), either in their original form or after being incorporated into other items, without first obtaining approval from the U.S. government or as otherwise authorized by U.S. law and regulations.”

Record of Revisions and Alterations		
Revision	Brief Description of Individual Change	Date Incorporated
0	Initial Issue	07/16/2024
1	Removed "EAR Controlled Data" for the whole report	09/05/2024

Signatures

Prepared by:



Caleb Zavala, Technical Writer

Approved by:



Dieu Vo, EMI/EMC Department Manager

Reviewed by:

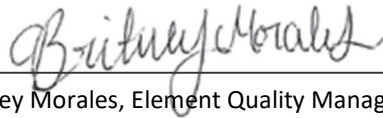

Britney Morales, Element Quality Management Rep.

Table of Contents

1	Introduction	6
1.1	Purpose	6
1.2	Acronyms	6
1.3	Definitions	6
2	References	7
3	Equipment Under Test	8
3.1	Description	8
3.2	Test Configuration	8
3.3	EMI Test Grounding Method	8
3.4	Security Classification	8
4	Test Requirements	9
4.1	Test Dates and Location	9
4.2	Test Resources	9
4.3	General Test Requirements	10
4.3.1	Test Facility	10
4.3.2	Ground Plane	10
4.3.3	Power Source Impedance	11
4.4	General Test Precautions	12
5	Test Descriptions and Results	13
5.1	Conducted Susceptibility: Method CS115 Bulk Cable Injection, Impulse Excitation	14
5.1.1	CS115 Purpose	14
5.1.2	CS115 Limit	14
5.1.3	CS115 Test Setup	14
5.1.4	CS115 Calibration	14
5.1.5	CS115 Test Procedure	14
5.1.6	CS115 Test Results	15
5.1.7	CS115 Test Photographs	15
5.1.8	CS115 Test Data	17
5.1.9	CS115 Test Equipment List	22
5.2	Conducted Susceptibility: Method CS116 Damped Sinusoidal Transients, Cables and Power Leads, 10 kHz–100 MHz	23
5.2.1	CS116 Purpose	23
5.2.2	CS116 Limits	23
5.2.3	CS116 Test Setup	23
5.2.4	CS116 Measurement System Check	23
5.2.5	CS116 Test Procedure	24
5.2.6	CS116 Test Results	24
5.2.7	CS116 Test Photographs	25
5.2.8	CS116 Test Data	26
5.2.9	CS116 Test Equipment	45
5.3	Conducted Susceptibility: Method CS117 Lightning Induced Transients, Cables and Power Leads	46
5.3.1	CS117 Purpose	46
5.3.2	CS117 Limits	46
5.3.3	CS117 Test Equipment	46
5.3.4	CS117 Test Setup	46
5.3.5	CS117 Test Procedure	47
5.3.6	CS117 Test Results	54
5.3.7	CS117 Test Photographs	55
5.3.8	CS117 Verification Test Data	76
5.3.9	CS117 Test Data on Inverter	121
5.3.1	CS117 Test Data on Battery Rack Mount	257
5.3.2	CS117 Test Data on Battery Wall Mount	303
5.3.3	CS117 Test Equipment	349

Table of Figures

Figure 4.3-1 EMC 24PCL RF Absorber Performance Data 10

Figure 4.3-2 EUT Bench Top 10

Figure 4.3-3 LISN Impedance Example 11

Figure CS115-1 Signal Characteristics for all Applications 14

Figure CS115-2 Calibration Setup 15

Figure CS115-3 Bulk Cable Injection 15

Figure CS116-1 Typical Damped Sinusoidal Waveform 23

Figure CS116-2 Limit for all Applications 23

Figure CS116-3 Typical Test Setup for System Measurement Check of Test Waveform 24

Figure CS116-4 Typical Setup for Bulk Cable Injection of Damped Sinusoidal Transients 24

Figure CS117-1 Current Waveform 1 49

Figure CS117-2 Voltage Waveform 2 49

Figure CS117-3 Voltage Waveform 3 50

Figure CS117-4 Voltage Waveform 4 50

Figure CS117-5 Current Waveform 5A 51

Figure CS117-6 Current Waveform 6 51

Figure CS117-7 Multiple Stroke Application 52

Figure CS117-8 Multiple Burst Application 52

Figure CS117-9 Typical test setup for calibration of lightning waveforms 53

Figure CS117-10 Typical setup for bulk cable injection of lightning transients on complete interconnecting cable bundles 53

Figure CS117-11 Typical setup for bulk cable injection of lightning transients on complete power cables (high sides and returns) 54

Figure CS117-12 Typical setup for bulk cable injection of lightning transients on power cables with power returns and chassis grounds excluded from the cable bundle 54

Tables of Tables

Table 2-1 Government Specifications, Standards, and Handbooks 7

Table 2-2 Other Documents, Drawings, and Publications 7

Table 3.1-1 Parametric Data for the 18kPV-12LV 8

Table 4.1-1 Test Dates and Locations 9

Table 4.1-2 MIL-STD-461G Test Completion Verification 9

Table 5-1 Test Results Summary 13

1 INTRODUCTION

1.1 Purpose

The purpose of this document is to present the procedures used and the results obtained during the performance of a MIL-STD-461G test program on the EUT. The test program was conducted to determine the ability of the EUT to successfully satisfy the requirements specified in the references listed in Section 2.0.

Client Information

This EMITR is contracted by EG4 Electronics LLC, Sulphur Springs, TX 75482.

Scope

This EMITR is applicable to the qualification of the 18kPV-12LV. The 18kPV-12LV is required to meet the requirements in MIL-STD-461G.

1.2 Acronyms

EUT: Equipment Under Test

EMI: Electromagnetic Interference

EMITR: Electromagnetic Interference Test Report

LISN: Line Impedance Stabilization Network

OLE: Object Linking and Embedding

RF: Radio Frequency

TPD: Terminal Protection Device

EMC: Electromagnetic Compatibility

EMITP: Electromagnetic Interference Test Procedure

ICS: Instrument Control System

ODBC: Open Database Connectivity

PSA: Performance Spectrum Analyzer

TEM: Transverse Electromagnetic

TILE: Total Integrated Laboratory Environment Software

1.3 Definitions

Decibel (dB) is a logarithmic unit of measurement that expresses the magnitude of a physical quantity (usually power or intensity) relative to a specified or implied reference level.

Metric Units are a system of measures defined by the International System on Units based on the “Le System International d’ Unites (SI)”, of the International Bureau of Weights and Measures. These units are described in ASTM E3380

Non-Developmental Item is a broad, generic term that covers material available from a wide variety of sources both industry and Government with little or no development effort required by the procuring activity.

Octave refers to the interval between one frequency and another with double its frequency.

Semi-Anechoic Chamber refers to a chamber with RF absorber lining on all walls and ceiling, but not the floor.

Safety Critical is a category of subsystems and equipment whose degraded performance could result in loss of life or loss of vehicle platform.

Test Setup Boundary includes all enclosures of the EUT and the 2 m of exposed interconnecting leads (except for leads which are shorter in actual installation) and power leads required by MIL-STD-461G.

2 REFERENCES

The following listed in Tables 2-1 and 2-2 form a part of this document to the extent specified herein.

Table 2-1 Government Specifications, Standards, and Handbooks

No	Specification	Rev	Title
1	MIL-STD-461	G	Department of Defense Interface Standard, Requirements for the Control of Electromagnetic Interference Characteristics of Subsystems and Equipment, dated December 11, 2015
2	MIL-STD-220	B	Method of Insertion Loss Measurement, dated June 25, 2004, with Change 1
3	DI-EMCS-80201C	C	Data Item Description Electromagnetic Interference Test Procedures (EMITP), dated August 30, 2007
4	S9407-AB-HBK-010	2	Handbook of Shipboard Electromagnetic Shielding Practices, dated September 30, 1989
5	DoDI 6055.11	N/A	Protecting Personnel from Electromagnetic Fields, dated August 19, 2009

Table 2-2 Other Documents, Drawings, and Publications

No	Specification	Title
6	POEG40233	Customer Name Purchase Order, dated 05/08/2024
7	OP0658121 - 0	Element Quotation to Customer Name, dated 05/03/2024
8	ISO/IEC 17025L:2017(E)	General Requirements for the Competence of Testing and Calibration Laboratories
9	Element SOP 110	Standard Operating Procedure – Electrical Safety dated June 4, 2012
10	Element SOP 114	Lock Out/Tag Out Procedure, dated November 2, 2010
11	ANSI C63.4-2003	American National Standard for Methods of Measurement of Radio Noise Emissions from Low-Voltage Electrical and Electronic Equipment in the Range of 9 kHz–40 GHz, 2003

3 EQUIPMENT UNDER TEST

3.1 Description

Table 3.1-1 lists key parametric data for the 18kPV-12LV

Table 3.1-1 Parametric Data for the 18kPV-12LV

Length:	34.3 inches	Weight:	121.25lbs
Width:	20.5 inches	Input Power:	208VAC/60 Hz and 28VDC
Height:	11.2 inches		

3.2 Test Configuration

To be supplied by customer.

3.3 EMI Test Grounding Method

The EUT was connected to the ground plane with a braided copper strap. The connection between the EUT and the ground plane was verified to be in accordance with installation guidelines. The ground braid construction is flat CRES 316 bond strap, 9 x 2 x 0.02”.

3.4 Security Classification

This equipment is considered an unclassified defense article. While unclassified, it should be handled only by authorized personnel. This equipment contains technical data within the definition of the International Traffic in Arms Regulations, and is subject to the export control laws of the USG. Retransfer of this data by any means to any Foreign Person, whether in the United States or abroad, without the written approval of the U. S. Department of State, is prohibited. See CFR 22 Parts 120-130.

4 TEST REQUIREMENTS

This section provides an overview of the EMI test plan.

4.1 Test Dates and Location

Table 4.1-1 Test Dates and Locations

Section	Test	MIL-STD-461G Section	Dates
5.1	CS115	5.13	06/13/2024
5.2	CS116	5.14	06/12/2024
5.3	CS117	5.15	06/14/2024 – 07/02/2024

Note: All testing was performed at Element in Plano, TX.

The following signatures record the testing that was performed in accordance with test procedures contained herein.

Table 4.1-2 MIL-STD-461G Test Completion Verification

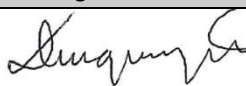
Signature indicates the test was supervised by Element representative.			
Test	Verified by	Signature	Date
CS115	Dieu Vo		06/13/2024
CS116			06/12/2024
CS117			06/14/2024 – 07/02/2024

4.2 Test Resources

Lists of the Element provided equipment used during testing are included in each test section. This equipment is calibrated according to ISO/IEC 17025:2017(E) and calibration is traceable to the National Institute of Standards and Technology (NIST). Calibration records are maintained on file at Element.

Test Personnel

Element provided a test operator and supervisory personnel to perform the test steps for each of the test procedures described in Section 5. The client provided support personnel to monitor the EUT performance and determine susceptibility of the EUT in accordance with criteria and procedures in Sections 3.3 and 4.5. During the performance of RE102 and RS103 these and all personnel were outside the test chamber with the door closed. During the performance of CS115 and CS116 these personnel may have been located inside the test chamber as required.

Test Equipment

The test chamber contained only necessary equipment to perform the test; anything that does not support the test was removed from the test chamber.

Ambient Electromagnetic Level

During testing, the ambient electromagnetic level measured with the EUT de-energized and all auxiliary equipment turned on was at least 6 dB below the allowable specified limits when the tests are performed in a shielded enclosure. Ambient conducted levels on power leads were measured with the leads disconnected from the EUT and connected to a resistive load which draws the same rated current as the EUT. When tests are performed in a shielded enclosure and the EUT is in compliance with required limits, the ambient profile need not be recorded in this EMITR. When measurements are made outside of a shielded enclosure the ambient conditions for temperature, humidity and barometric pressure are recorded. The ambient conditions were recorded in this EMITR and they did not compromise the test results.

4.3 General Test Requirements

4.3.1 Test Facility

All testing occurred within a shielded semi anechoic enclosure, located in Plano, TX. The chamber is lined with anechoic Radio Frequency (RF) absorbing cones on the walls and the ceiling. Peripheral equipment was located outside the shielded enclosure. All power leads entering the shielded enclosures were routed via electromagnetic interference filters to provide at least 80 dB of attenuation above 10 kHz when measured in accordance with MIL-STD-220B. Interconnecting cables were routed via feed-through ports mounted on the enclosure. Shielding effectiveness to electric fields and plane waves of this EMI test chamber exceeded 80 dB from 14 kHz–10 GHz, and 60 dB from 10 GHz–40 GHz.

The anechoic RF absorber material shown in Figure 4.3-1 (carbon impregnated foam pyramids) is used when performing electric field radiated emissions or radiated susceptibility testing inside a shielded enclosure. It is intended to reduce reflections of electromagnetic energy and to improve accuracy and repeatability.

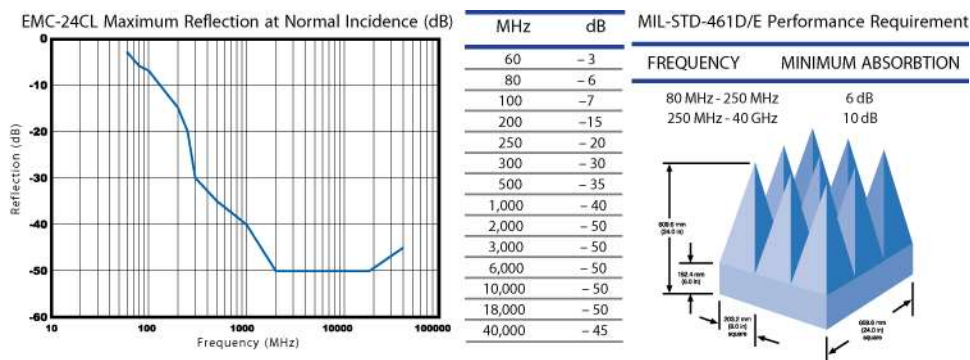

Figure 4.3-1 EMC 24PCL RF Absorber Performance Data

4.3.2 Ground Plane

The ground plane was a copper plane, measuring 350 cm x 89 cm, placed on a table inside the shielded enclosure. The shielded enclosure measures 20' x 18' x 10'. The EUT was bonded to the ground through a ground strap provided by EG4 Electronics LLC. The ground plane met the requirements of MIL STD-461G.

The EUT was installed on a metallic ground plane as shown in Figure 4.3-2. Equipment orientation in relation to ground plane and antennae was determined after near-field probe of equipment determined the greatest source of emissions. For purposes of test planning, it was assumed that the front face of the EUT was the worst case for emissions and susceptibility as the other faces of the EUT are continuous metal construction with the exception of the bottom face which allows cable penetration. See Figure 4.3-2 for details of the Element provided fixture to simulate shipboard installation.

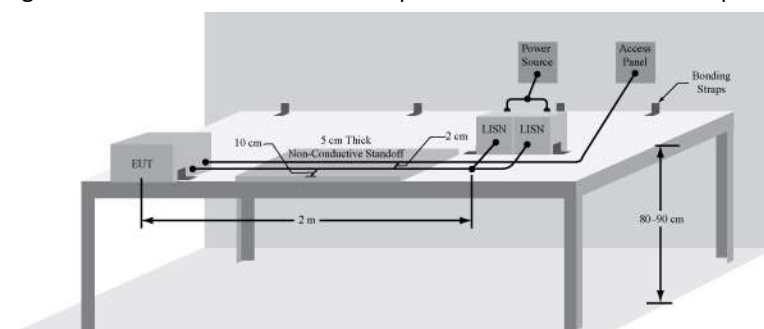

Figure 4.3-2 EUT Bench Top

4.3.3 Power Source Impedance

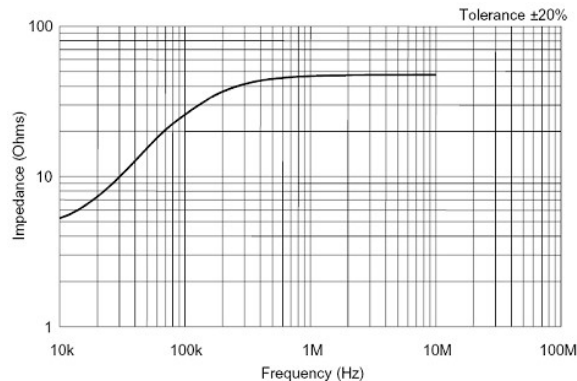

Figure 4.3-3 LISN Impedance Example

The impedance of power sources providing input power to the EUT were controlled by LISNs for all measurement procedures of this document unless otherwise stated in a particular test procedure. LISNs were not used on output power leads. The LISNs were located at the power source end of the 2.5 m exposed length of power leads. The LISN impedance characteristics were in accordance with Figure 4.3-3. The LISN impedance was measured at least annually under the following conditions:

- The impedance was measured between the power output lead on the load side of the LISN and the metal enclosure of the LISN.
- The LISN signal output port had a 50 ohm termination.

The power input terminal on the power source side of the LISN was un-terminated. The impedance measurement results are provided in this EMITR.

Frequency Accuracy

In order for the EUT to successfully satisfy the requirements specified in the references listed in Section 2.0, the frequency accuracy of the recorded measurements was within $\pm 2\%$. Verification with a frequency counter or other measuring device was required. Amplitude Accuracy was ± 2 dB.

Other Accuracies

- Distance: $\pm 5\%$
- Amplitude, measurement system (includes measurement receivers, transducers, cables, and so forth): ± 3 dB
- Time (waveforms): $\pm 5\%$
- Resistors: $\pm 5\%$
- Capacitors: $\pm 20\%$

4.4 General Test Precautions

Excess Personnel and Equipment

The test area was kept free of unnecessary personnel, equipment, cable racks, and desks. Only the equipment essential to the test being performed was in the test area or enclosure. Only personnel actively involved in the test was permitted in the enclosure.

Overload Precautions

Measurement receivers and transducers are subject to overload, especially receivers without pre-selectors and active transducers. Periodic checks were performed to assure that an over-load condition did not exist. Instrumentation changes were implemented to correct any overload condition.

Linear Response of Signal

In accordance with ANSI C63.4-2003 Clause 4.2, the measuring system satisfied the following condition:

- The measuring system shall have a linear response.

If a non-linear response was suspected due to an overload condition, the linearity response of the measurement system was verified. This was accomplished by performing a continuous sweep across the measurement range. A second sweep was performed with external RF attenuation added to the front end of the spectrum analyzer to confirm that the measurement amplitude at the suspect frequencies were reduced corresponding to the amount of attenuation applied.

For example, a linear response would be verified if a 30 dB signal measured through a 10 dB attenuator reads 20 dB, and reads 10 dB through a 20 dB attenuator. A non-linear response would be verified if a 30 dB signal reads a value higher than expected through a given attenuator (non-linear response: 30 dB input – 10 dB attenuator = 27.5 dB)

If a non-linear response was verified, the addition of more external attenuation or internal attenuation with an RF reference level adjustment was required to regain a linear measurement response. Newer models of EMI Receivers such as the Agilent E4446A series indicate where an IF or RF overload exists. In this case, the attenuation of the analyzer's input signal was adjusted until the overload indication was removed.

RF Hazards

Some tests in this report result in electromagnetic fields that were potentially dangerous to personnel. The permissible exposure levels in DoDI 6055.11 did not exceed in areas where personnel are present. Safety procedures and devices were used to prevent accidental exposure of personnel to RF hazards.

Shock Hazard

Some tests require potentially hazardous voltages to be present. Extreme caution was taken by all personnel to assure that all safety precautions were observed.

See the Element Standard Operating Procedure SOP 110 for electrical safety and SOP114 for Lock-Out Tag-Out procedures.

5 TEST DESCRIPTIONS AND RESULTS**Table 5-1 Test Results Summary**

Section	Test	Met Criteria?
5.1	MIL-STD-461G CS115	Yes
5.2	MIL-STD-461G CS116	Yes
5.3	MIL-STD-461G CS117	Yes

*The decision rule used to state compliance is in accordance with the test specification used for testing.

5.1 Conducted Susceptibility: Method CS115 Bulk Cable Injection, Impulse Excitation

5.1.1 CS115 Purpose

This test verifies the ability of the EUT to withstand impulse signals coupled onto its cables.

5.1.2 CS115 Limit

The EUT shall not exhibit any malfunction, degradation of performance, or deviation from specified indications beyond the tolerances indicated in the individual equipment or subsystems specification when subjected to a pre-calibrated signal having rise and fall times, pulse width, and amplitude as specified in Figure CS115-1 at a 30 Hz rate for 1 minute.

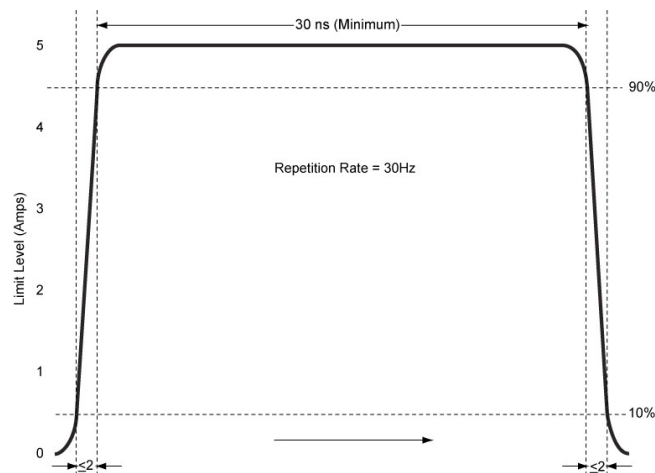

Figure CS115-1 Signal Characteristics for all Applications

5.1.3 CS115 Test Setup

The EUT was setup in accordance with Figure 4.3-1 and Section 3.2.

5.1.4 CS115 Calibration

The test equipment is configured per Figure CS115-2. The injection probe is calibrated as follows:

1. The injection probe is placed around the center conductor of the calibration fixture.
2. One end of the calibration fixture is terminated with a coaxial load. The other end is terminated with an attenuator connected to an oscilloscope with 50ohm input impedance.

Calibration proceeds as follows:

1. The measurement equipment is turned on and sufficient time is allowed for stabilization.
2. The pulse generator source is adjusted for the rise time, pulse width, and pulse repetition rate requirements.
3. The signal applied to the calibration fixture is increased until the oscilloscope indicates that the required current level is flowing in the center conductor of the calibration fixture.
4. It is verified that the rise time, fall time, and pulse width portions of the waveform have the correct durations, and that the correct repetition rate is present. Note that the precise pulse shape cannot be reproduced due to the inductive coupling mechanism.
5. The pulse generator amplitude setting is recorded.

5.1.5 CS115 Test Procedure

The test equipment is configured per Figure CS115-3, and as follows:

1. The injection and monitor probes are placed around the cable bundle interfacing with a/an EUT connector.
2. The monitor probe is placed 5 cm from the connector. If the connector and backshell's overall length exceeds 5 cm, the monitor probe is positioned as close to the connector's backshell as possible.
3. The injection probe is positioned 5 cm from the monitor probe.

Testing proceeds as follows on all required cables:

1. The EUT is turned on and sufficient time is allowed for stabilization.
2. Susceptibility Evaluation:
 - A. The pulse generator is adjusted, as a minimum, for the amplitude setting determined in Step 5 of the previous Calibration Procedure.
 - B. The test signal is applied at the pulse repetition rate for the required duration.
 - C. The EUT is monitored for degradation of performance.
 - D. If susceptibility is noted, the threshold level is determined and it is verified to be above the limit.
 - E. The peak current induced on the cable is recorded off the oscilloscope.
 - F. Steps A–E are repeated on each cable bundle interfacing with each electrical connector on the EUT.

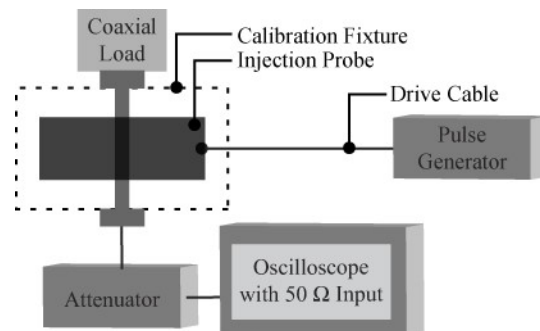

Figure CS115-2 Calibration Setup

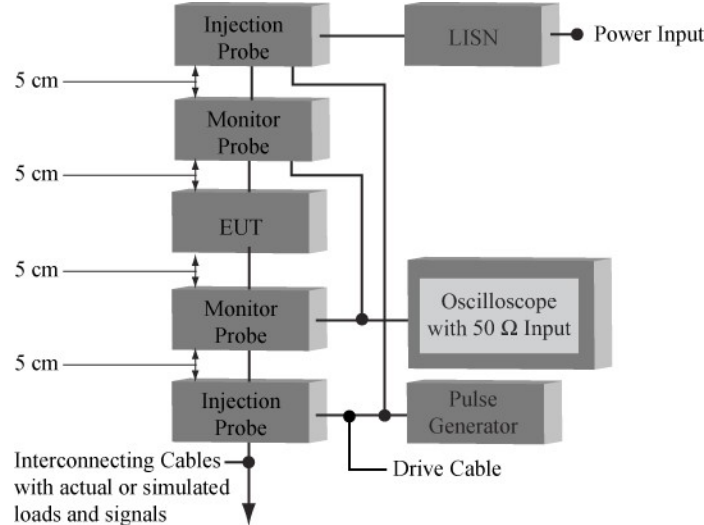

Figure CS115-3 Bulk Cable Injection

5.1.6 CS115 Test Results

The EUT **complied** with the requirements in Section 2.0.

5.1.7 CS115 Test Photographs



CS115 Test AC Bundle

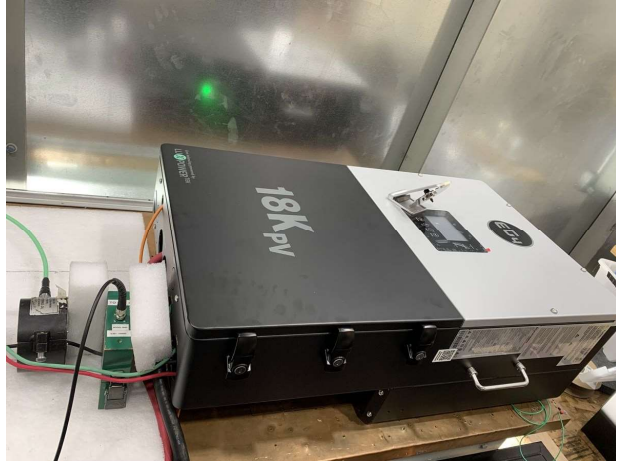

CS115 Test AC L1

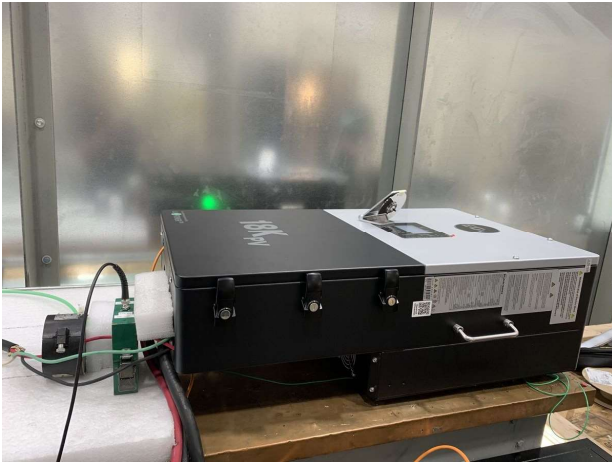

CS115 Test AC L2



CS115 Test DC Bundle



CS115 Test DC High Side

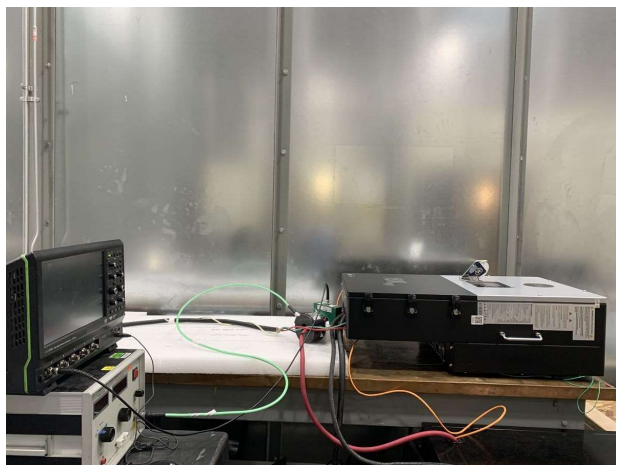

CS115 Test Setup

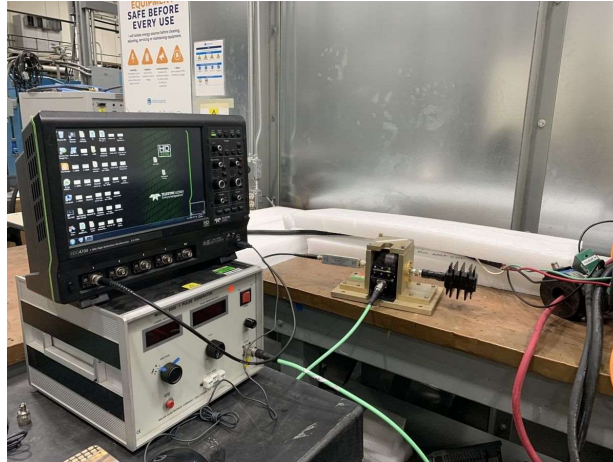

CS115 Verification Setup

5.1.8 CS115 Test Data

CUSTOMER:	EG4 Electronics LLC		MJO:	PR183529	
TEST ITEM:	18kPV-12LV		DATE:	6/13/2024	
PART NUMBER	OD00.0000601		UNIT NO:	EMI # 1	
SPECIFICATION:	MIL-STD-461G		CHAMBER NO:	N/A	
EUT Power Input			208VAC/60Hz and 48VDC		
Limit			5A		
CS115 Conducted Susceptibility, Bulk Cable Injection, Impulse Excitation					
Test Level: 30 nanosecond pulse width @ 5 Amps. Pulse rate at 30 Hz per second for one minute.					
Temperature: 22c		Humidity: 54%		Barometric Pressure: 998mBars	
Frequency	Test Level (A)	Actual Test (A)	Test on Cable	Results	Comments
30nS Impulse Excitation	5	≥ 5	AC Bundle	<input checked="" type="checkbox"/> Pass	
30nS Impulse Excitation	5	≥ 5	AC L1	<input checked="" type="checkbox"/> Pass	
30nS Impulse Excitation	5	≥ 5	AC L2	<input checked="" type="checkbox"/> Pass	
30nS Impulse Excitation	5	≥ 5	DC Bundle	<input checked="" type="checkbox"/> Pass	
30nS Impulse Excitation	5	≥ 5	High Side	<input checked="" type="checkbox"/> Pass	
TECHNICIAN / ENGINEER:		Phuoc Tran		DATE:	6/13/2024

CS115 Verification Test Data for Impulse Excitation Test

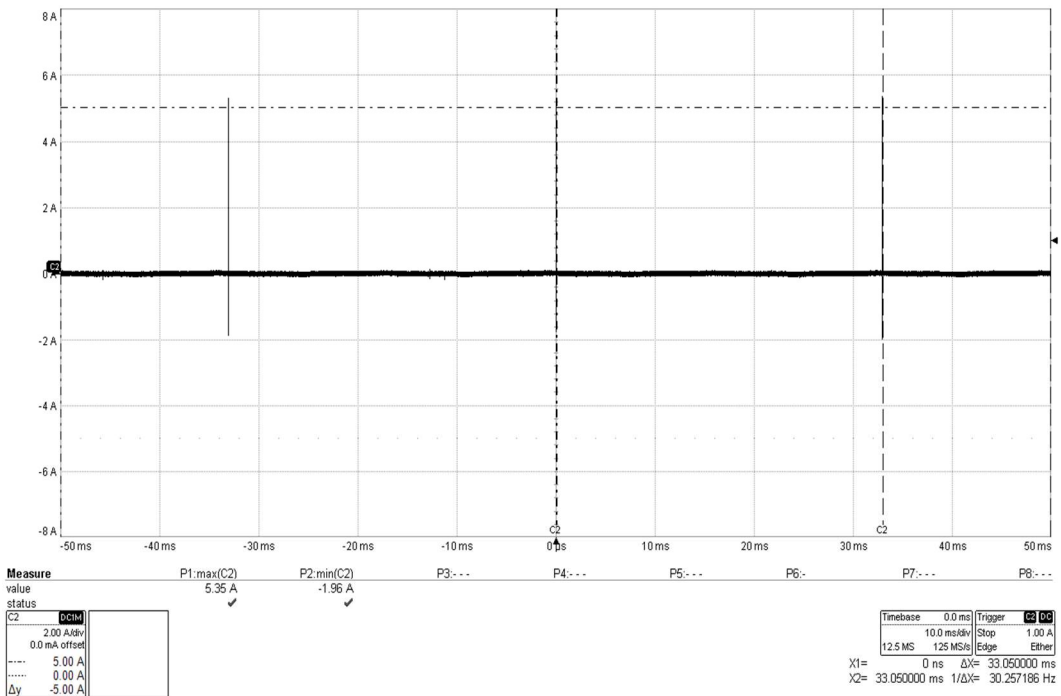

CS115 Verification 30Hz

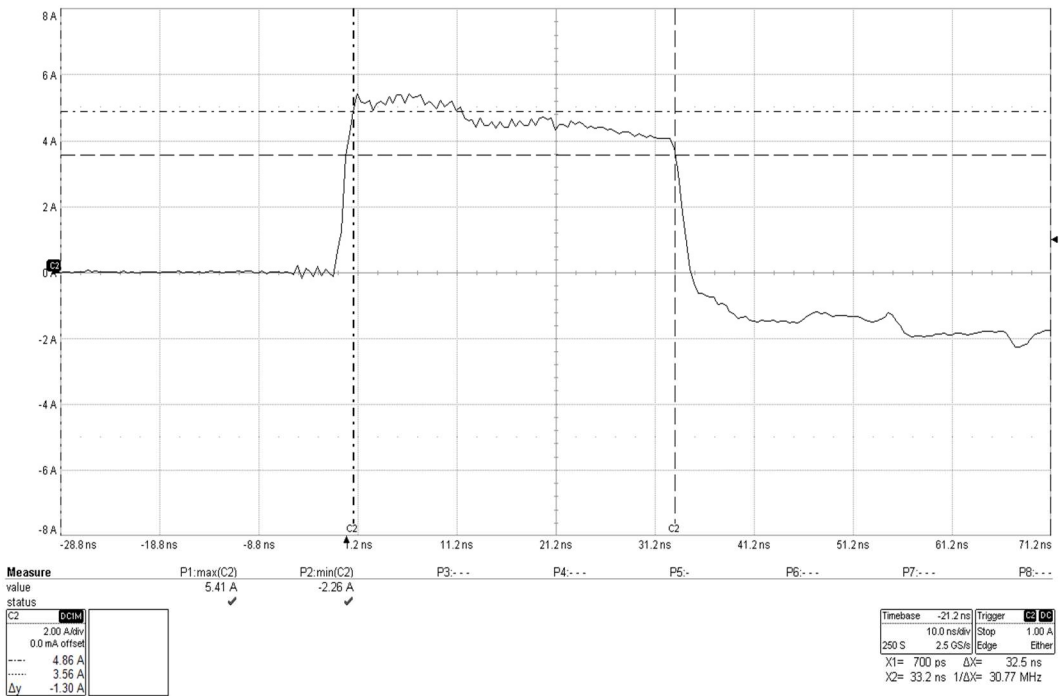

CS115 Verification 30nsec

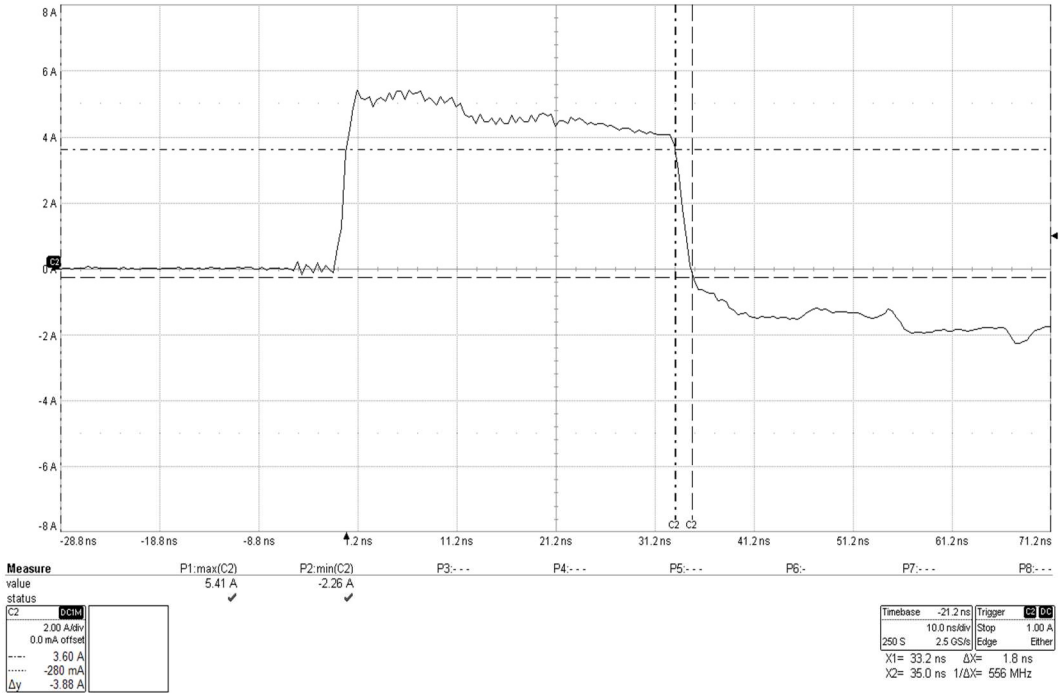

CS115 Verification Fall Time

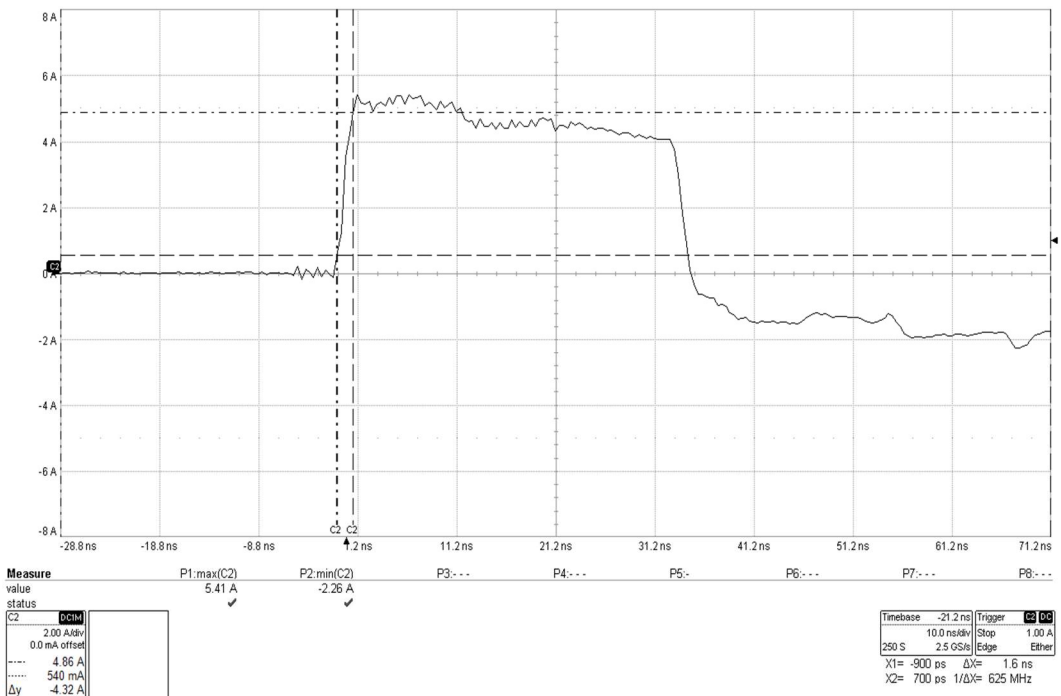

CS115 Verification Rise Time

CS115 Actual Test Data for Impulse Excitation Test

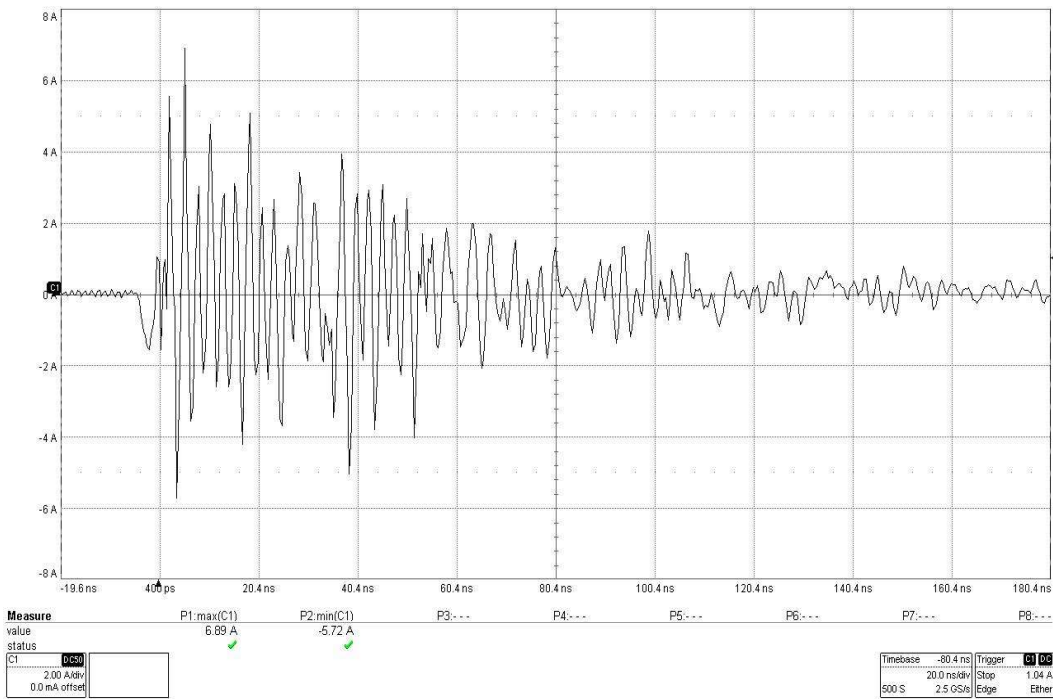

CS115 Test on AC Bundle

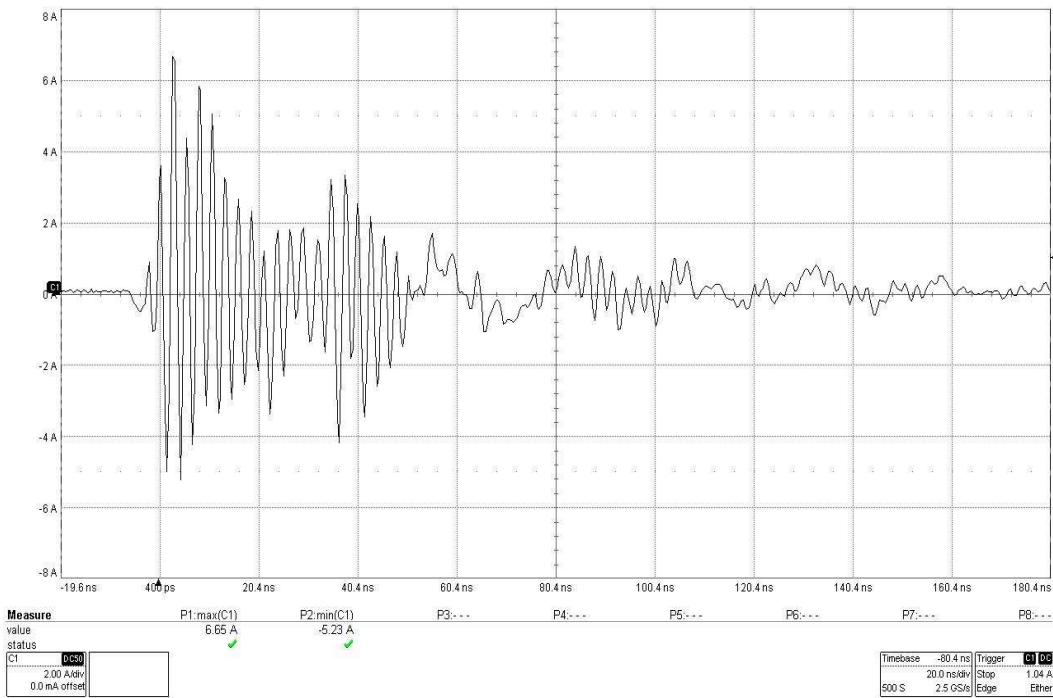

CS115 Test on AC L1

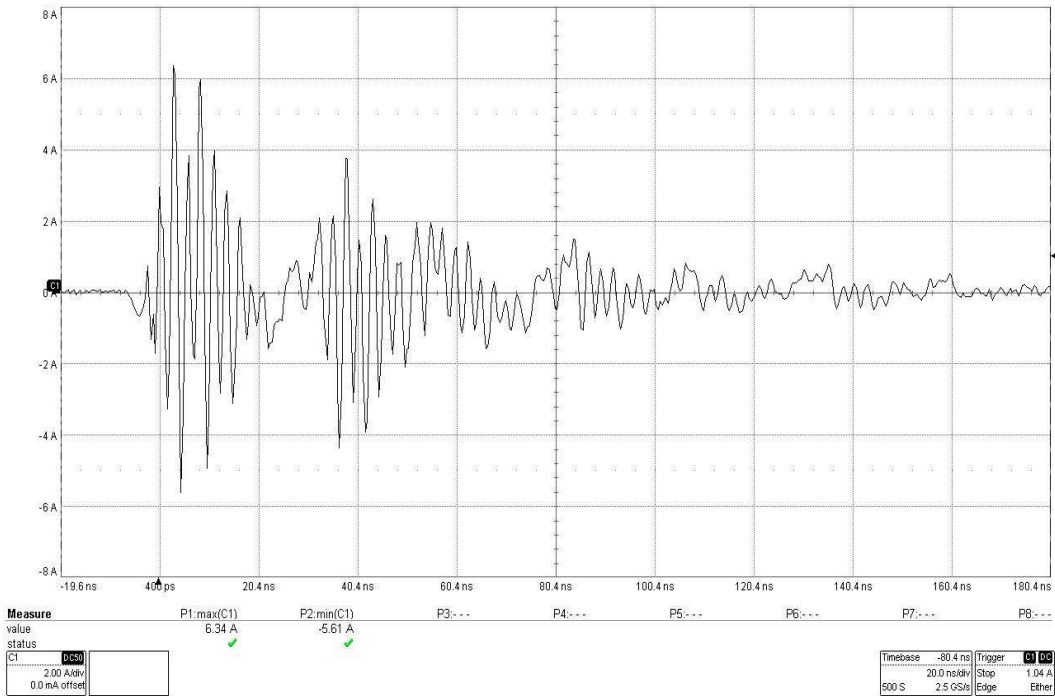

CS115 Test on AC L2

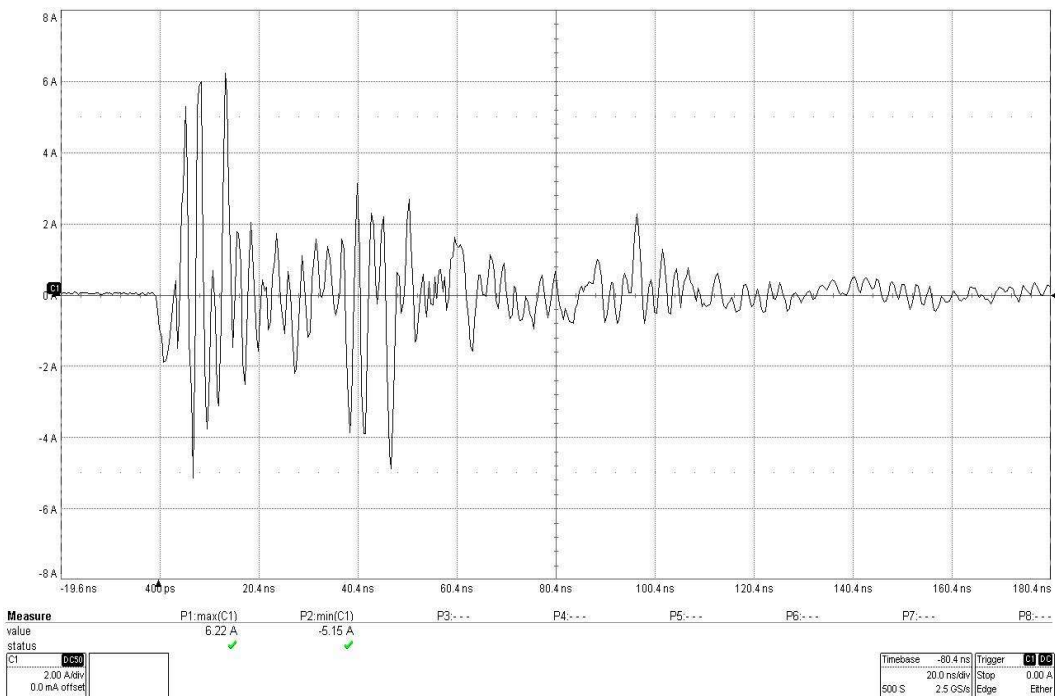

CS115 Test on DC Bundle

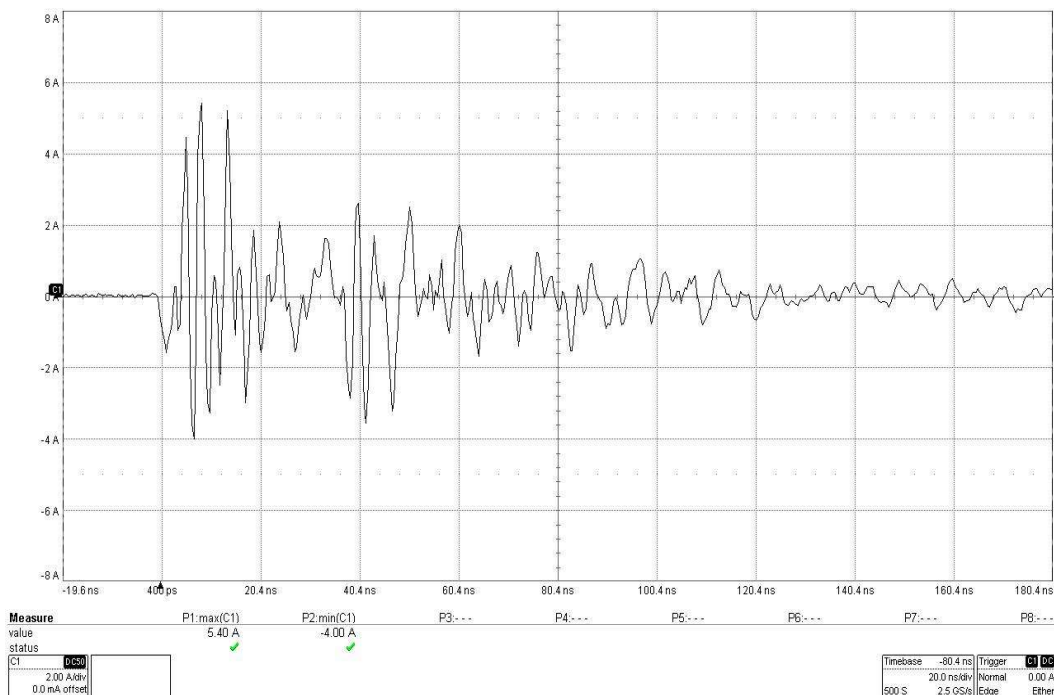

CS115 Test on DC High Side

5.1.9 CS115 Test Equipment List

CS115 Impulse Excitation Test Equipment List			
Element ID#	Manufacturer/ Description	Duration	Cal Due
WC038473	Teledyne Lecroy, 1GHz High Definition Oscilloscope, Model: HDO4104, 2.5GS	12 months	1/16/2025
WC021043	Pearson Monitor (Current), 1000X, Model 5664, SN# 081309	12 months	3/20/2025
WC021527	Solar Pulse Generator Model 9355-1	NCR	NCR
WC021267	Solar Electronics, Current Injection Probe, Type: 9142-1N, 2MHz-450MHz, 100V	NCR	NCR
WC038569	Weinschel Bi-Directional Attenuator Model 24-10-34-LIM	NCR	NCR
WC020926	Solar Electronics, Calibration Fixture, Type: 9125-1	NCR	NCR
WC066513	High Voltage Attenuator	NCR	NCR
WC066519	Relm, 50ohm RF Load, Model: T44004, DC-4GHz, 100W	NCR	NCR
WC021313	Solar Network (LISN) 8028-50-TS-24-BNC 10 kHz to 50 MHz	12 months	4/11/2025
WC021338	Solar Network (LISN) 8028-50-TS-24-BNC 10 kHz to 50 MHz	12 months	11/20/2024

Calibration Abbreviation

NCR: No Calibration Required

5.2 Conducted Susceptibility: Method CS116 Damped Sinusoidal Transients, Cables and Power Leads, 10 kHz–100 MHz

5.2.1 CS116 Purpose

This test verifies the ability of the EUT to withstand damped sinusoidal transients coupled onto its cables and power leads.

5.2.2 CS116 Limits

The EUT did not exhibit any malfunction, degradation of performance, or deviation from specified indications beyond the tolerances indicated in the individual equipment or subsystem specification when subjected to the signal shown in Figure CS116-1 and having a maximum current as specified in Figure CS116-2.

The limit is applicable across the entire specified frequency range. As a minimum, compliance shall be demonstrated at the following frequencies: 0.01, 0.1, 1, 10, 30, and 100MHz. If there are other frequencies known to be critical to the equipment installation, such as platform resonances, compliance shall also be demonstrated at those frequencies. The test signal repetition rate shall be no greater than one pulse per second and no less than one pulse every two seconds. The pulses shall be applied for a period of five minutes.

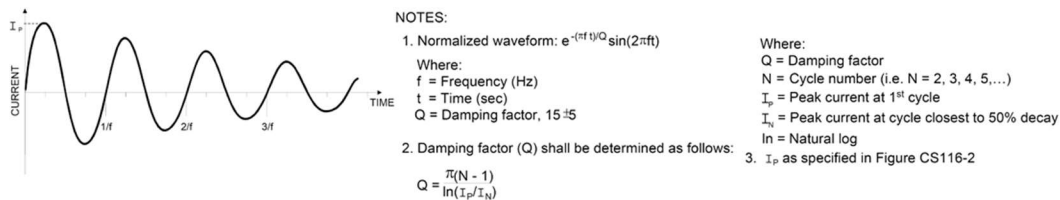

Figure CS116-1 Typical Damped Sinusoidal Waveform

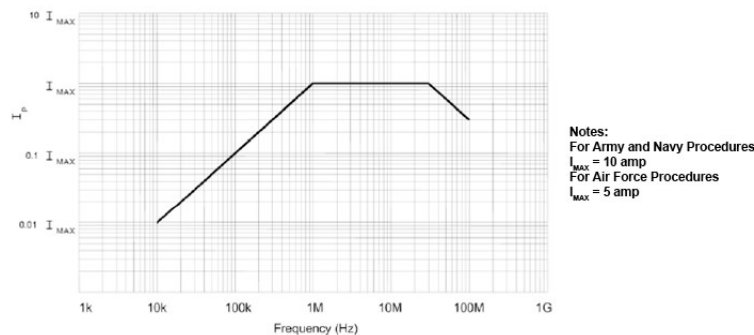

Figure CS116-2 Limit for all Applications

5.2.3 CS116 Test Setup

The EUT was setup in accordance with Section 3.3.

5.2.4 CS116 Measurement System Check

The test equipment was configured per Figure CS116-3.

1. The measurement system check was performed prior to testing specified in Section 5.8.5.
2. The measurement equipment was turned on and sufficient time was allowed for stabilization.
3. The frequency of the damped sine generator was set to one of the test frequencies defined in Section 5.8.2.
4. The signal from the damped sine generator was adjusted to the level specified Figure CS116-2.
5. The damped sine generator settings were recorded.
6. The waveform complied with the requirements.
7. The pulse repetition rate was between 1 to 2 pulses per second. The actual rate was recorded.
8. Frequency, amplitude, and damping factor were recorded

9. Steps 3–8 were repeated for each frequency specified Section 5.8.2.

5.2.5 CS116 Test Procedure

The test equipment was configured per Figure CS116-4, and as follows:

1. The injection and monitor probes were placed around the cable bundle interfacing with a EUT connector.
2. The monitor probe was placed 5 cm from the connector. If the connector and backshell's overall length exceeded 5 cm, the monitor probe was positioned as close to the connector's backshell as possible.
3. The injection probe was positioned 5 cm from the monitor probe.

Testing proceeded as follows on all required cables and power leads:

1. The EUT and the measurement equipment were turned on and sufficient time was allowed for stabilization.
2. The damped sine generator was set to a test frequency.
3. The test signals were applied to each cable or power lead sequentially.
 - A. The damped sine wave generator's output level was slowly increased to provide current without exceeding the pre-calibrated generator output level.
 - B. The peak current was recorded.
 - C. The EUT was monitored for degradation of performance during the 5 minute pulsing period.
 - D. The peak current obtained while being applied to the cable was recorded.
4. Step 3 was repeated for each test frequency, as specified in the requirement.
 - If susceptibility was noted, the threshold level was determined, and it was verified to be above the limit in accordance with Section 4.5.
5. Steps 2–4 were repeated in the power-off condition.

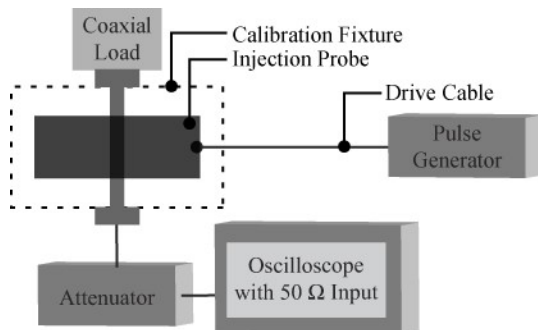

Figure CS116-3 Typical Test Setup for System Measurement Check of Test Waveform

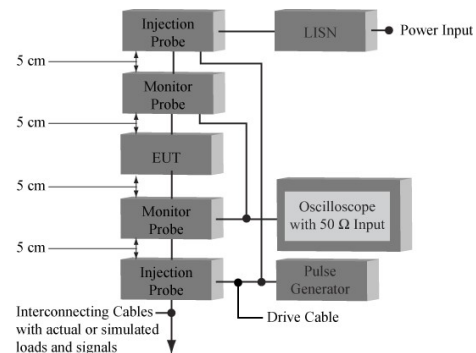
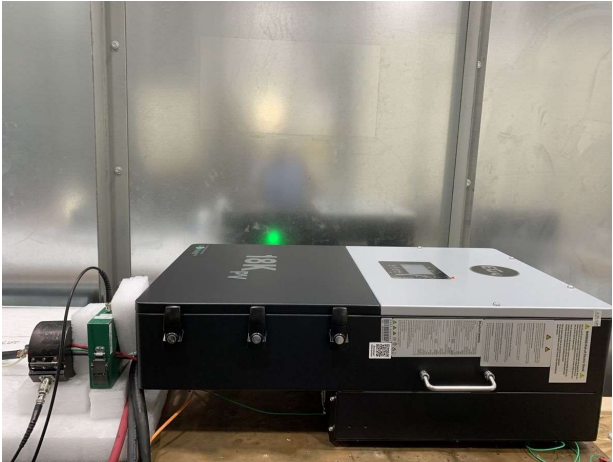

Figure CS116-4 Typical Setup for Bulk Cable Injection of Damped Sinusoidal Transients

5.2.6 CS116 Test Results

The EUT **complied** with the requirements in Section 2.0.

5.2.7 CS116 Test Photographs



CS116 Test AC Bundle

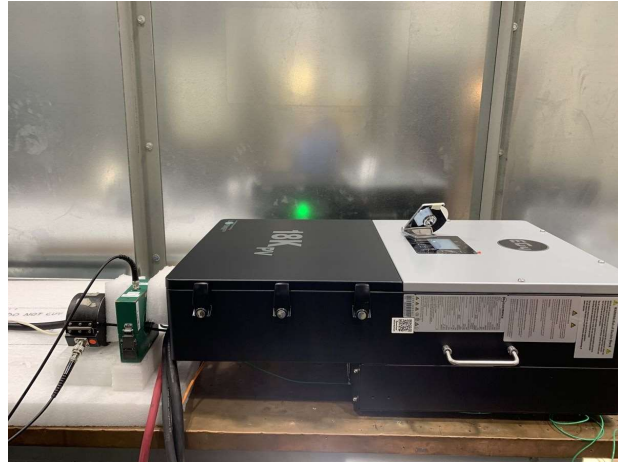

CS116 Test AC L1

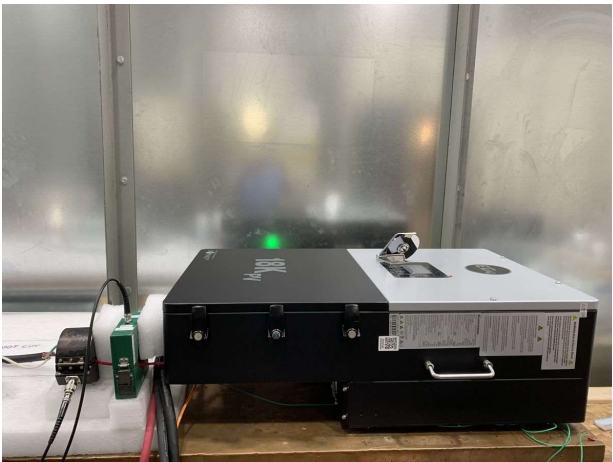

CS116 Test AC L2



CS116 Test DC Bundle



CS116 Test DC High Side



CS116 Test Setup (1)

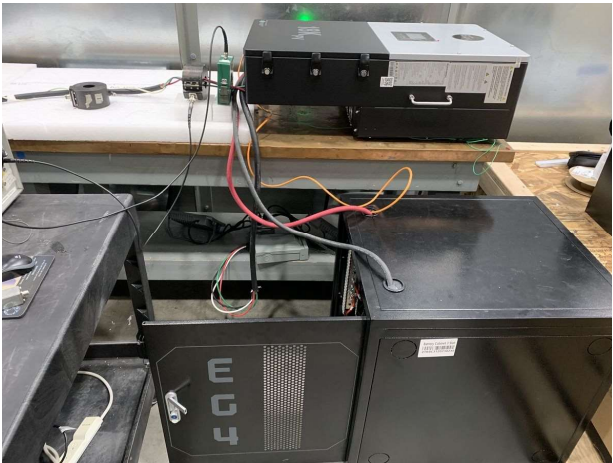

CS116 Test Setup (2)

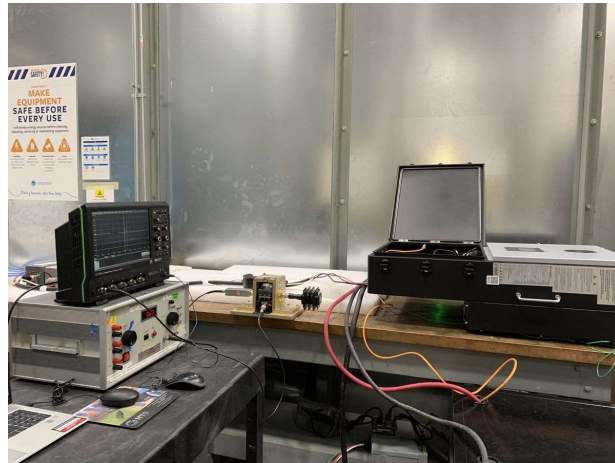

CS116 Verification Setup

5.2.8 CS116 Test Data

CUSTOMER:	EG4 Electronics LLC		MJO:	PRI83529			
TEST ITEM:	18kPV-12LV		DATE:	6/12/2024			
PART NUMBER:	OD00.0000601		UNIT NO:	EMI # 1			
SPECIFICATION:	MIL-STD-461G		CHAMBER NO:	N/A			
EUT Power Input			208VAC/60Hz and 48VDC				
CS116 Conducted Susceptibility, Damped Sinusoidal Transients							
Test Level: For Army and Navy procurements, IMAX = 10A							
Temperature: 22C		Humidity: 54%		Barometric Pressure: 998mBars			
Remarks: The EUT was monitored for susceptibility during the performance of the test. The pulses shall be applied for a period of five minutes per frequency. All Bundle, Power Bundle and Each individual High Side Power Lead.							
Frequency/ Level	0.01MHz	0.1MHz	1MHz	10MHz	30MHz	100MHz	Comments
Cable under test	0.1A/5V	1A/50V	10A/500V	10A/500V	10A/500V	3A/150V	
AC Bundle	Pass AR	Pass AR	Pass AR	Pass VR	Pass VR	Pass VR	VR
ACL1	Pass VR	Pass VR	Pass VR	Pass VR	Pass VR	Pass VR	Voltage Reached
ACL2	Pass VR	Pass VR	Pass VR	Pass VR	Pass VR	Pass VR	AR
DC Bundle	Pass AR	Pass AR	Pass AR	Pass AR	Pass AR	Pass AR	Current Reached
High Side	Pass AR	Pass AR	Pass AR	Pass AR	Pass AR	Pass AR	
TECHNICIAN / ENGINEER:			Phuoc Tran		DATE:		6/12/2024

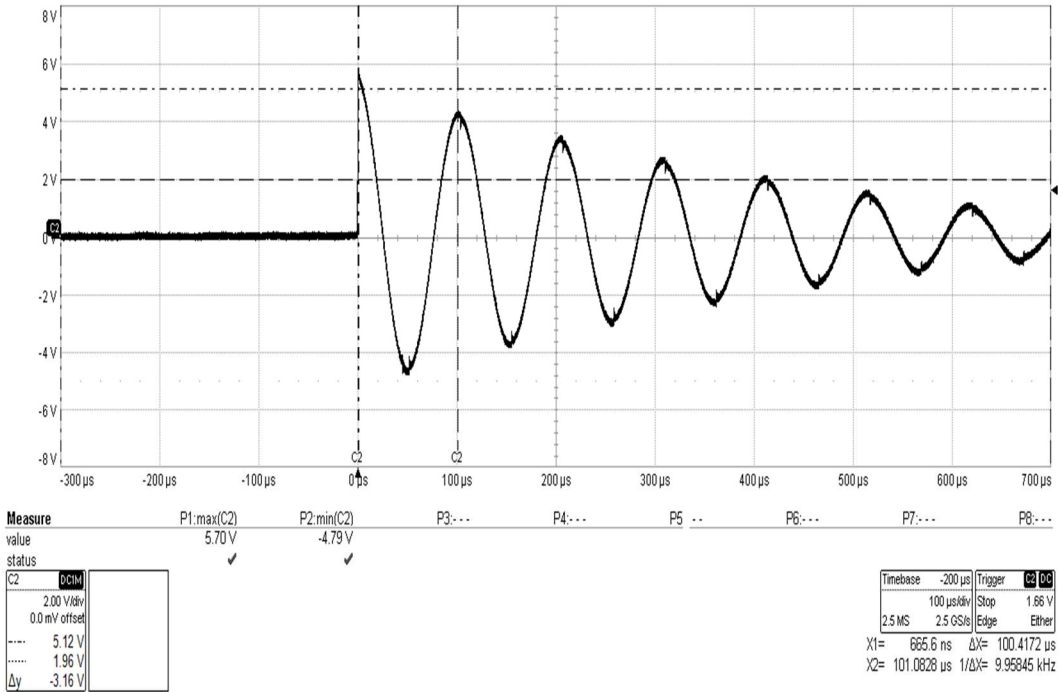
CS116 Verification Test Data from 10 kHz – 100MHz

Verification CS116 Damped Sinusoidal Transient Test at 10 kHz

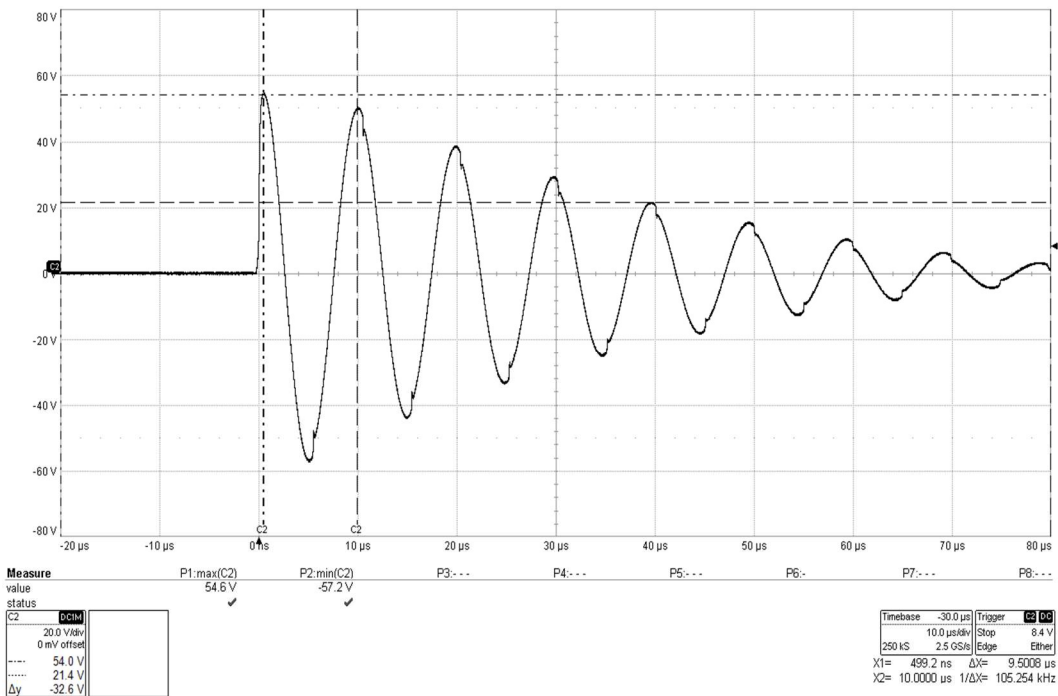

Verification CS116 Damped Sinusoidal Transient Test at 100 kHz

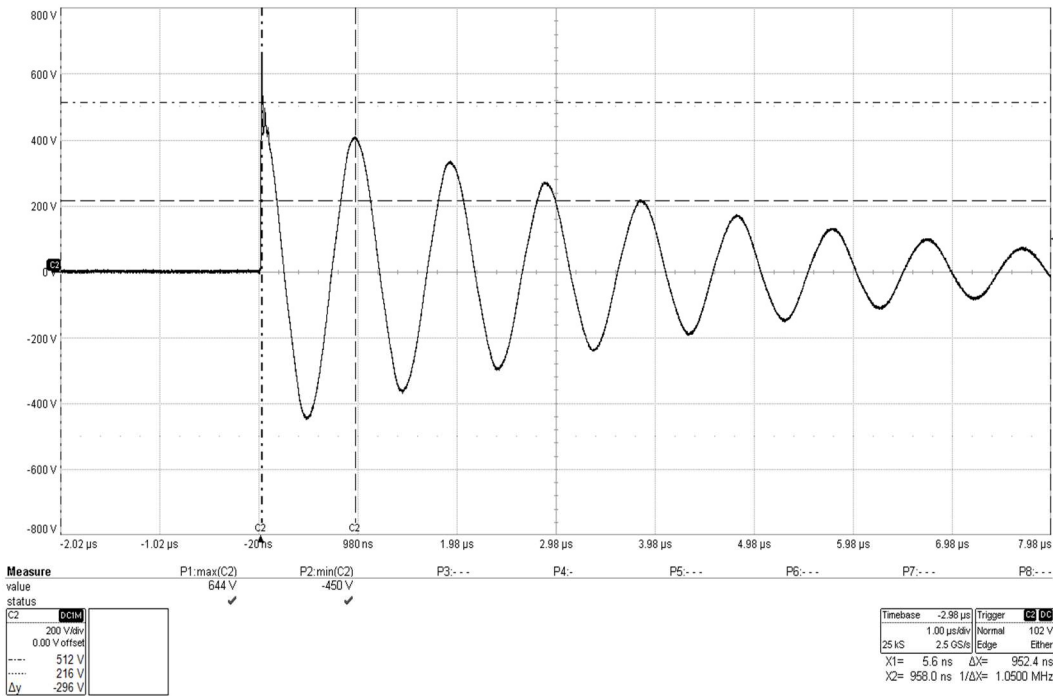

Verification CS116 Damped Sinusoidal Transient Test at 1MHz

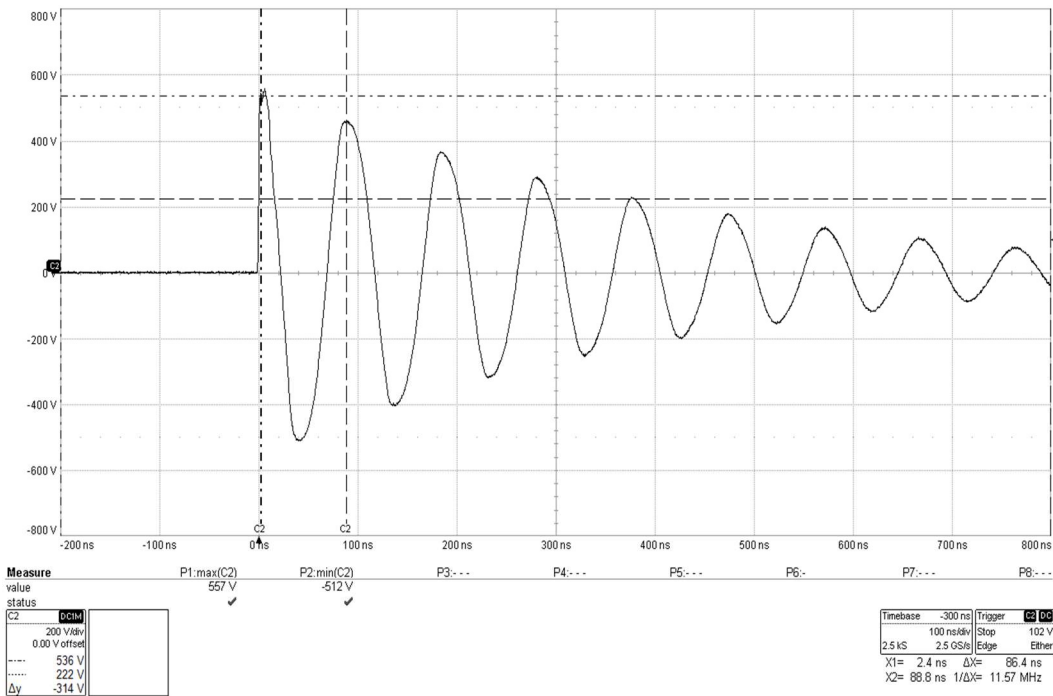

Verification CS116 Damped Sinusoidal Transient Test at 10MHz

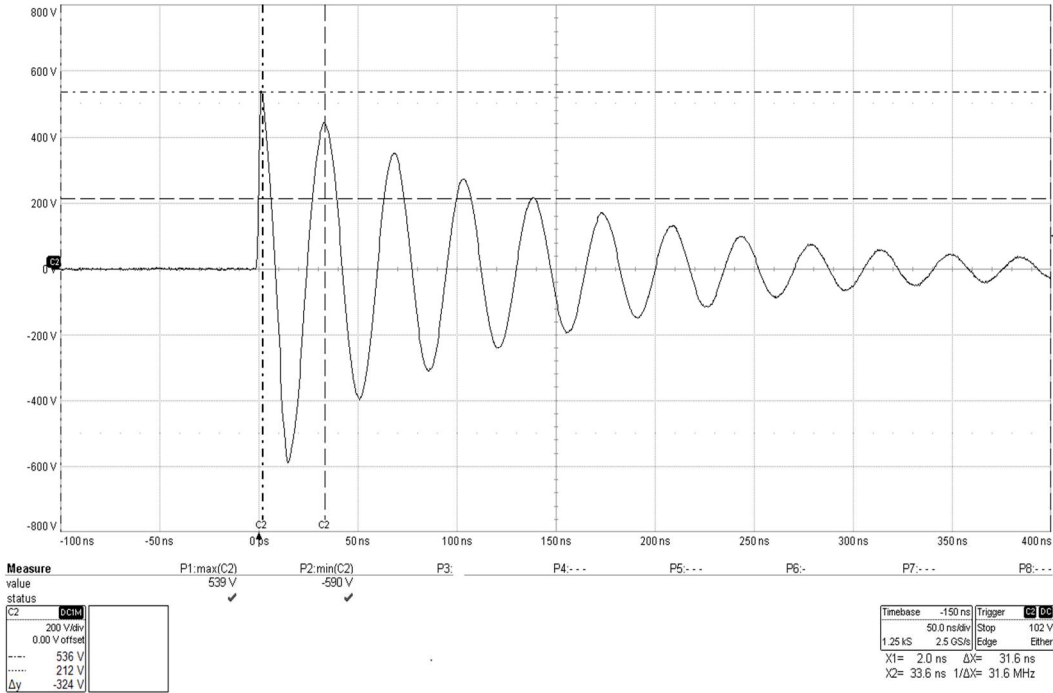

Verification CS116 Damped Sinusoidal Transient Test at 30MHz

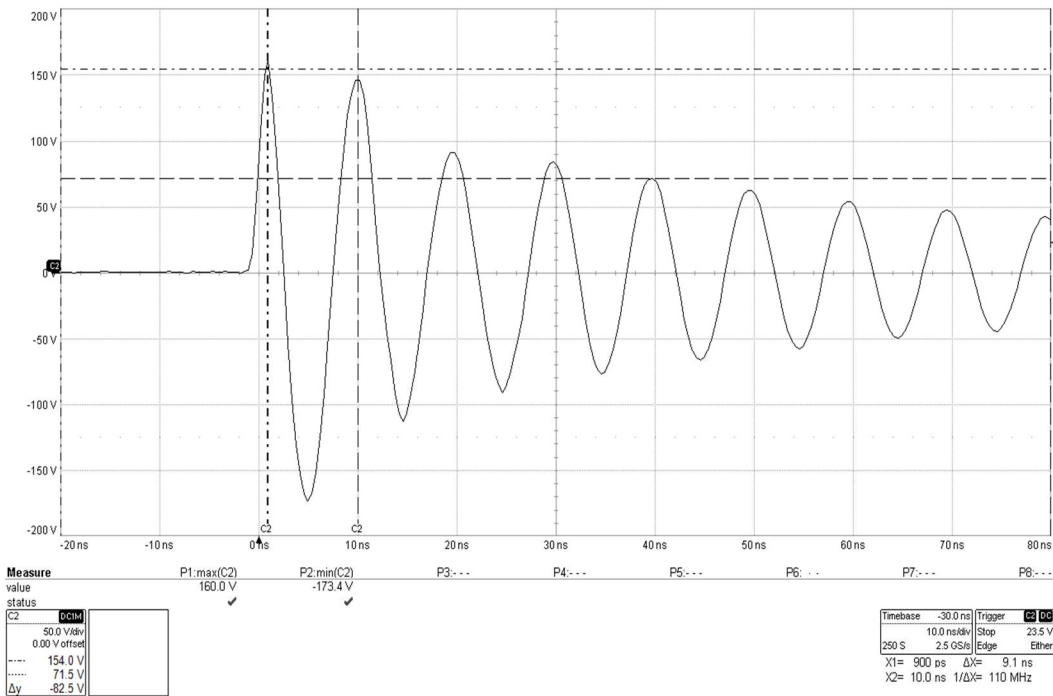

Verification CS116 Damped Sinusoidal Transient Test at 100MHz

CS116 Actual Test Data from 10 kHz – 100MHz

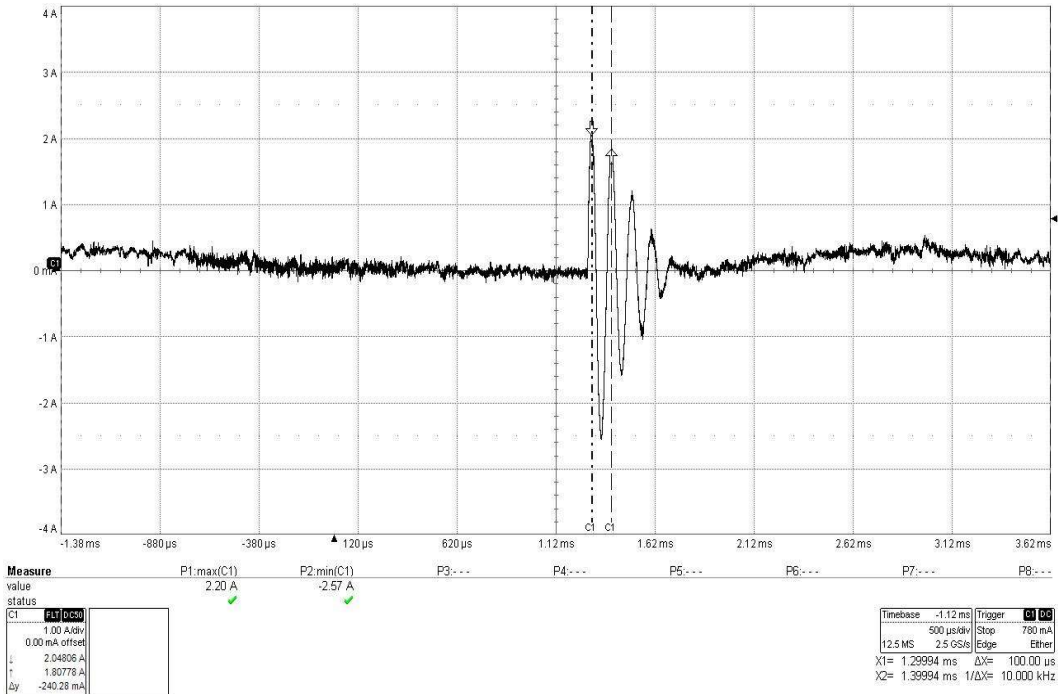

Actual CS116 Damped Sinusoidal Transient Test at 10 kHz on AC Bundle

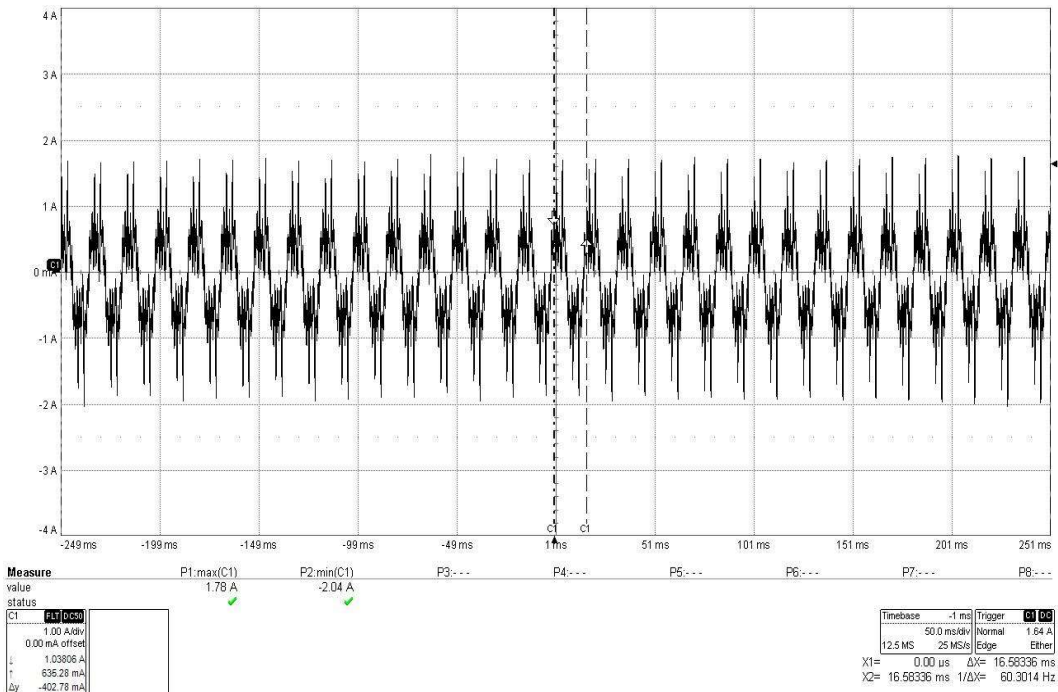

Actual CS116 Damped Sinusoidal Transient Test at 10 kHz on AC L1

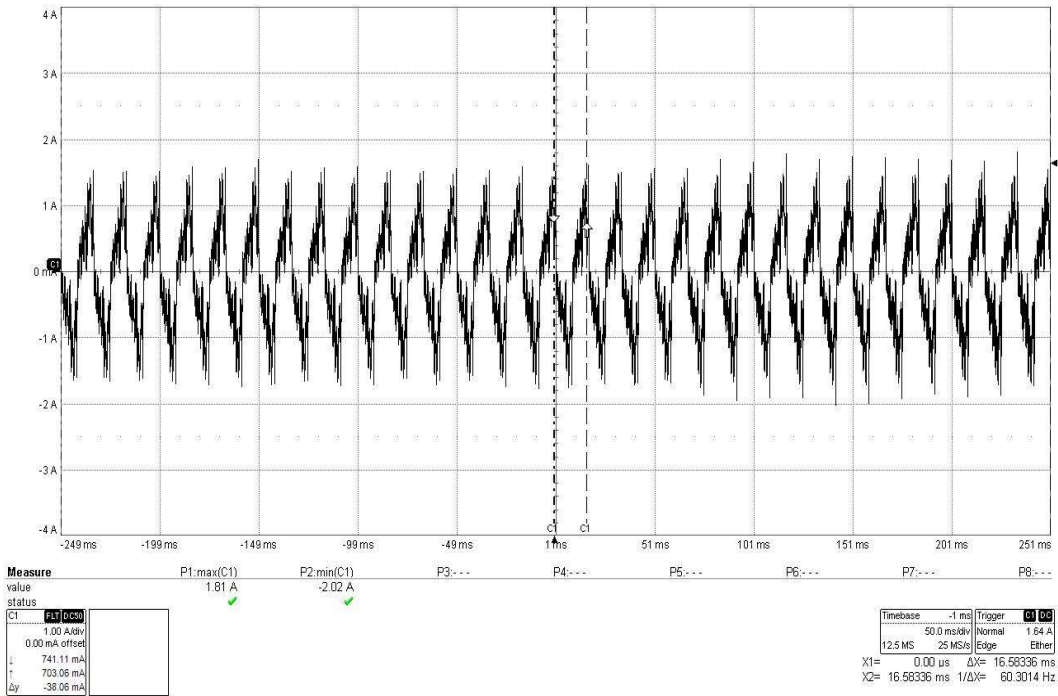

Actual CS116 Damped Sinusoidal Transient Test at 10 kHz on AC L2

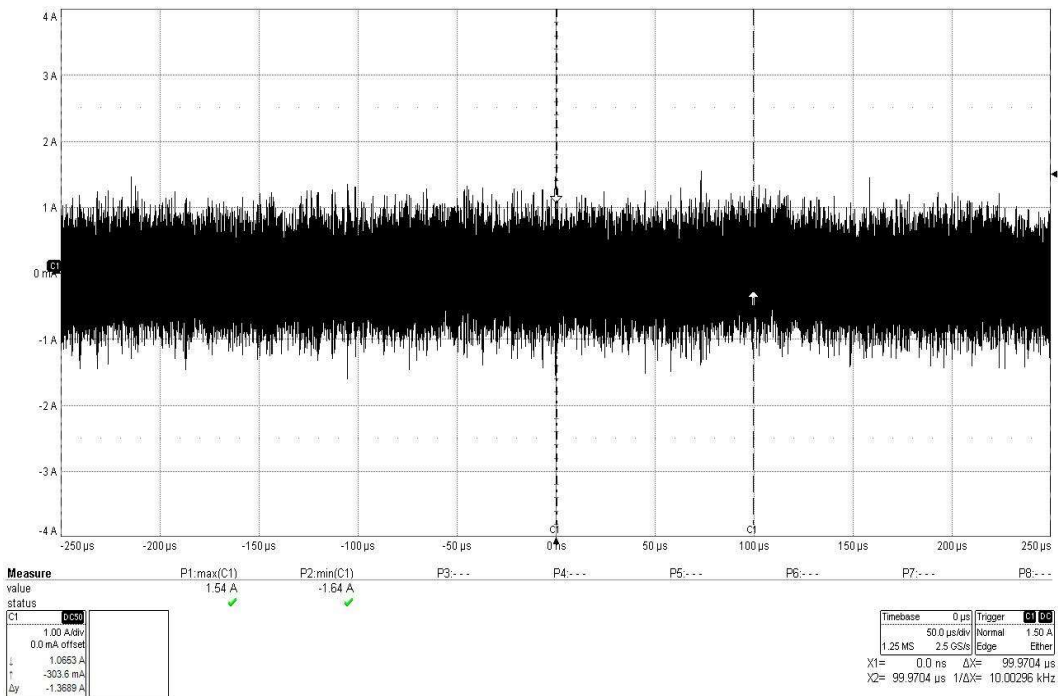

Actual CS116 Damped Sinusoidal Transient Test at 10 kHz on DC Bundle

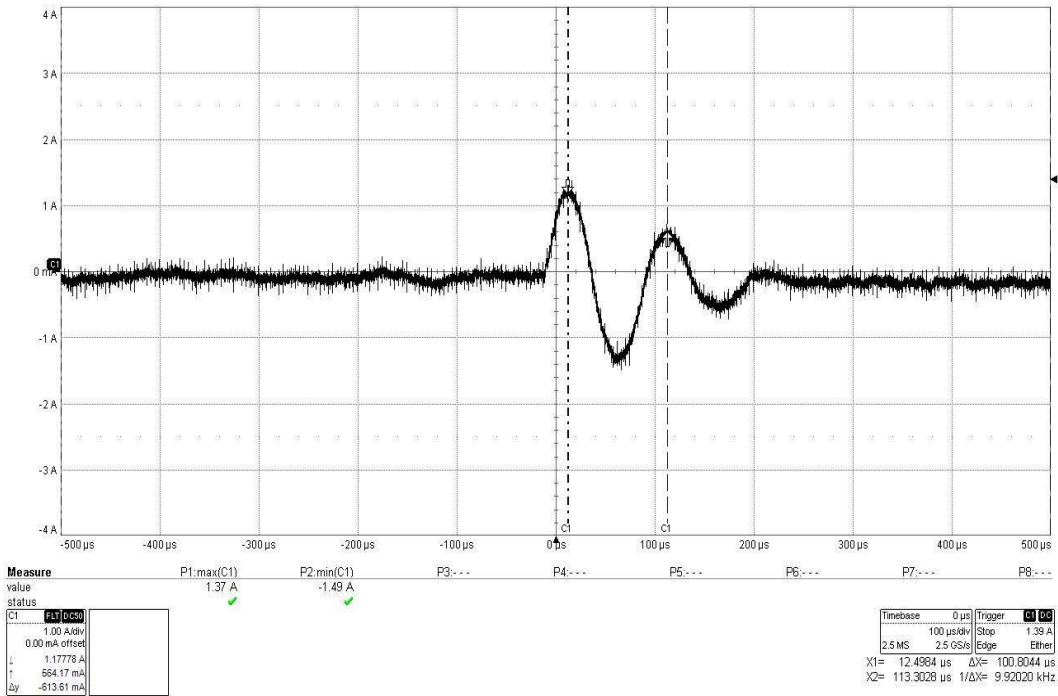

Actual CS116 Damped Sinusoidal Transient Test at 10 kHz on DC High Side

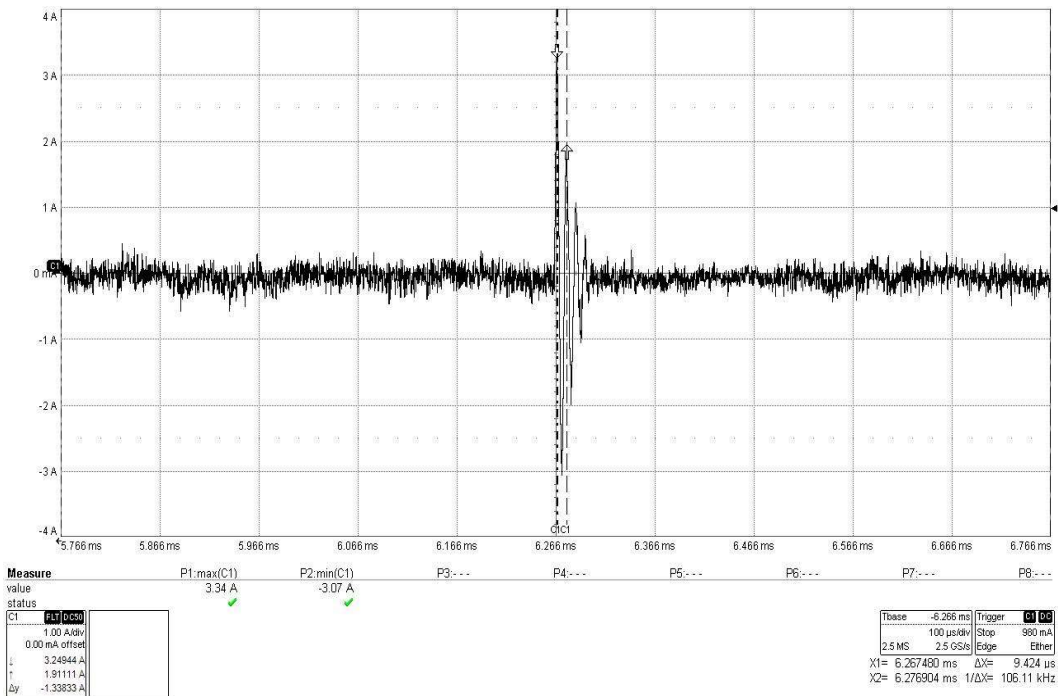

Actual CS116 Damped Sinusoidal Transient Test at 100 kHz on AC Bundle

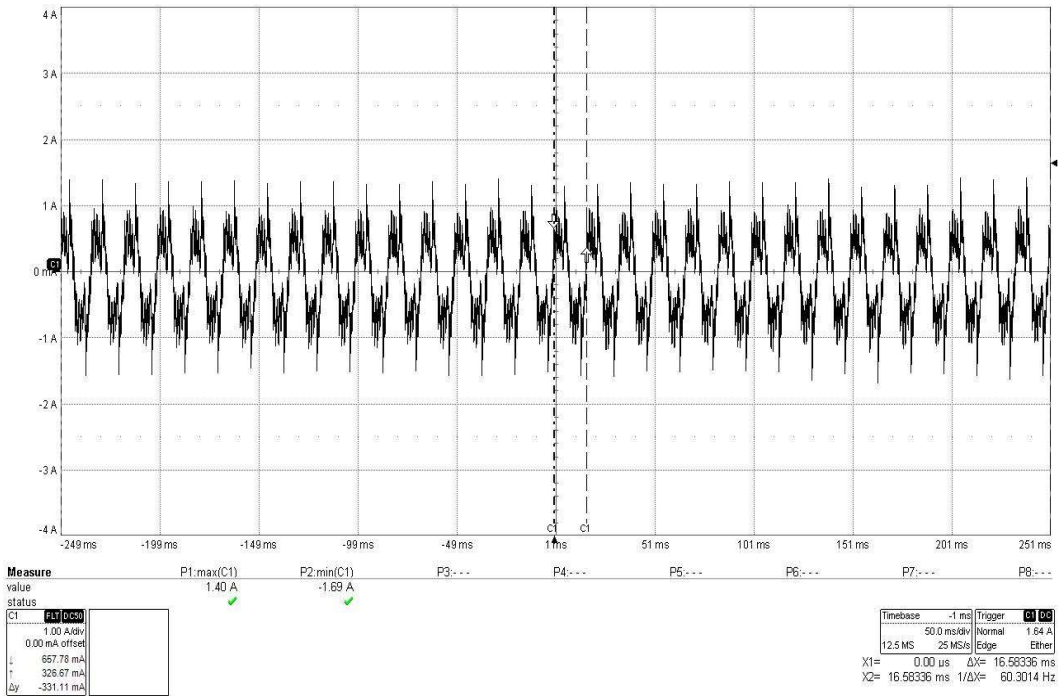

Actual CS116 Damped Sinusoidal Transient Test at 100 kHz on AC L1

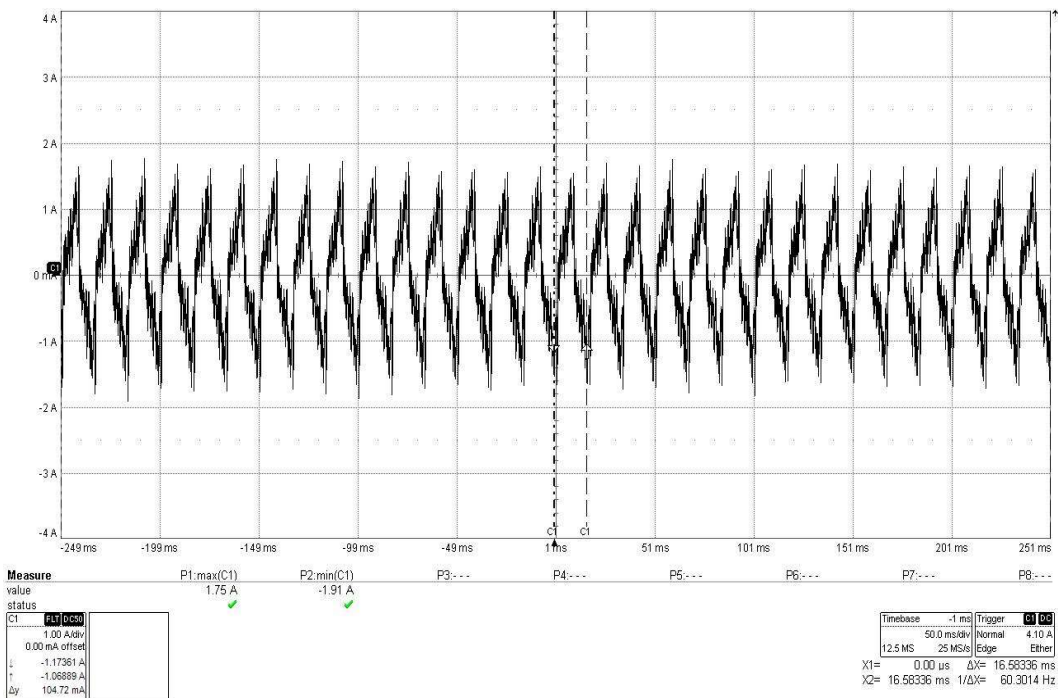

Actual CS116 Damped Sinusoidal Transient Test at 100 kHz on AC L2

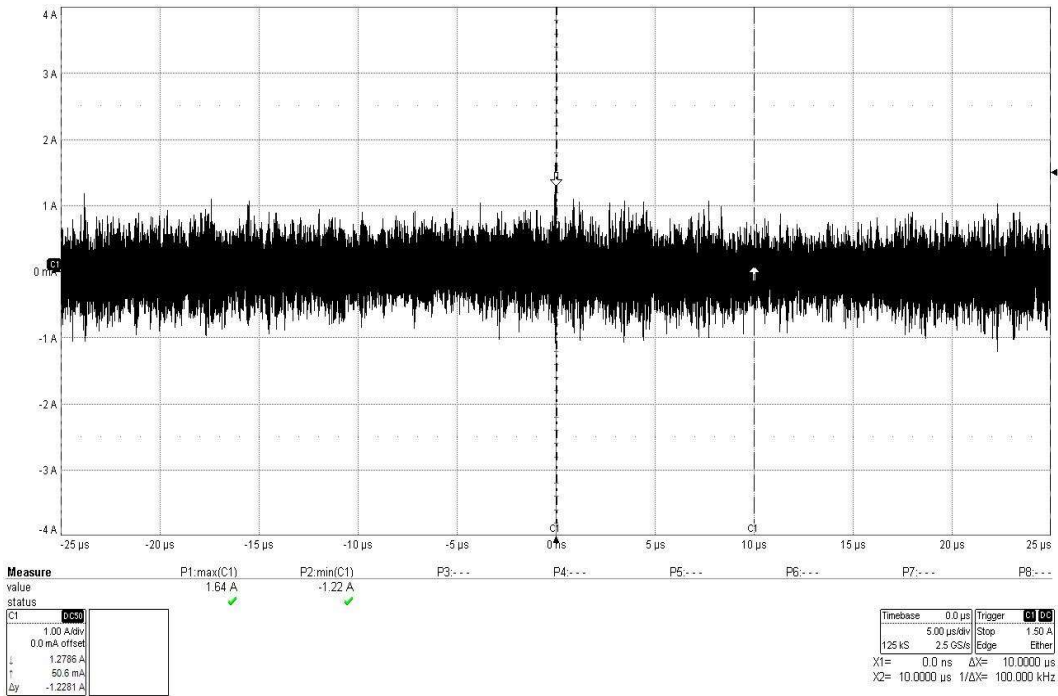

Actual CS116 Damped Sinusoidal Transient Test at 100 kHz on DC Bundle

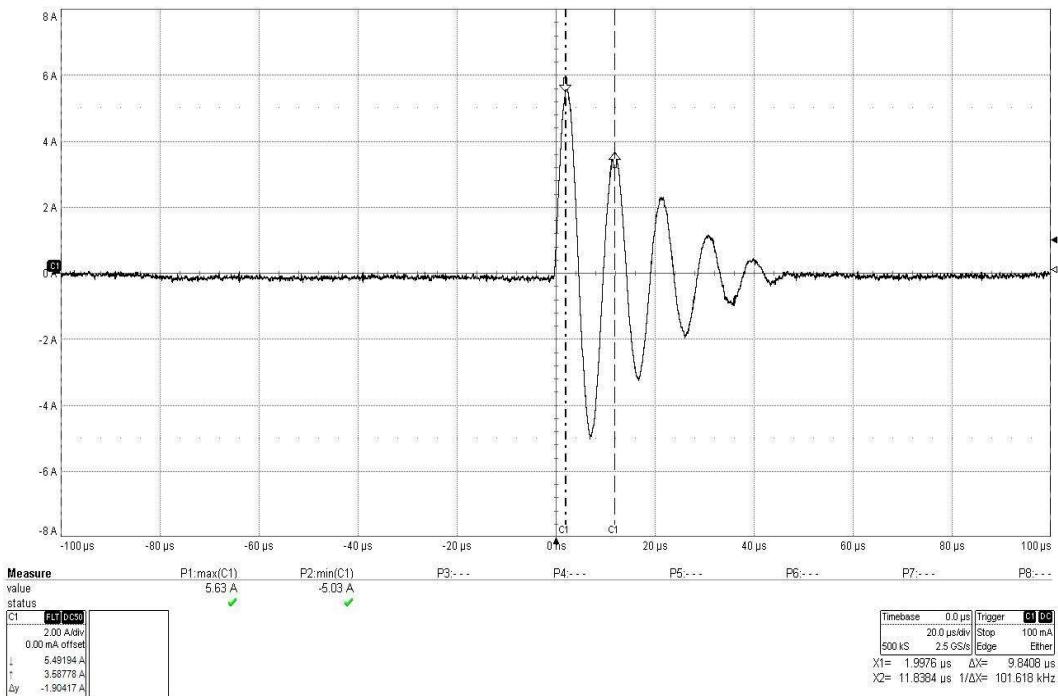

Actual CS116 Damped Sinusoidal Transient Test at 100 kHz on DC High Side

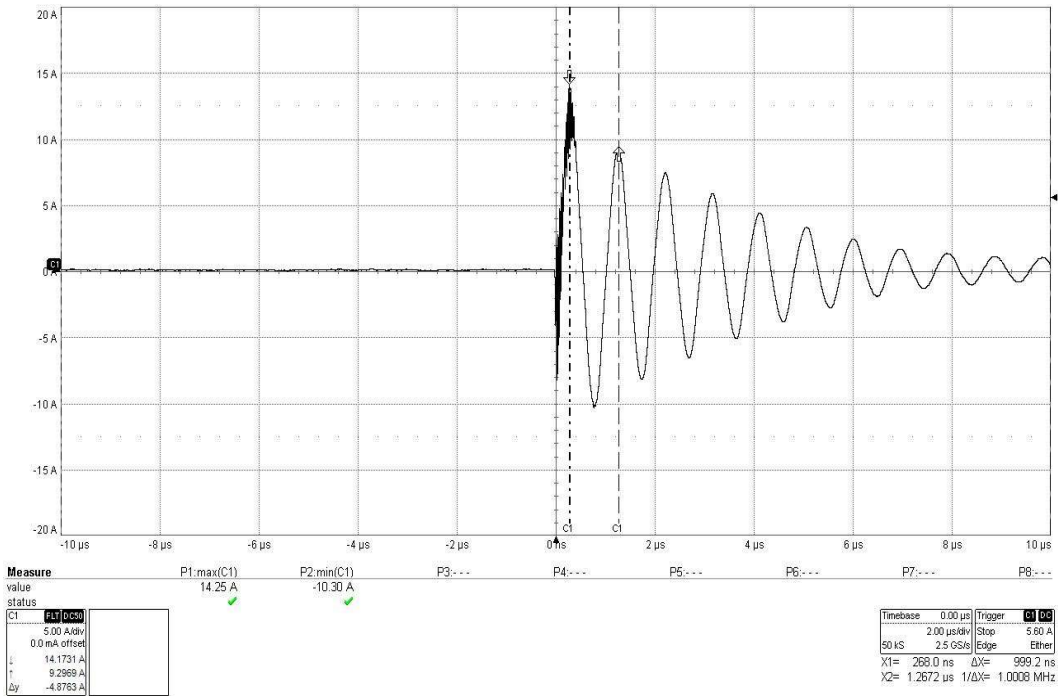

Actual CS116 Damped Sinusoidal Transient Test at 1 MHz on AC Bundle

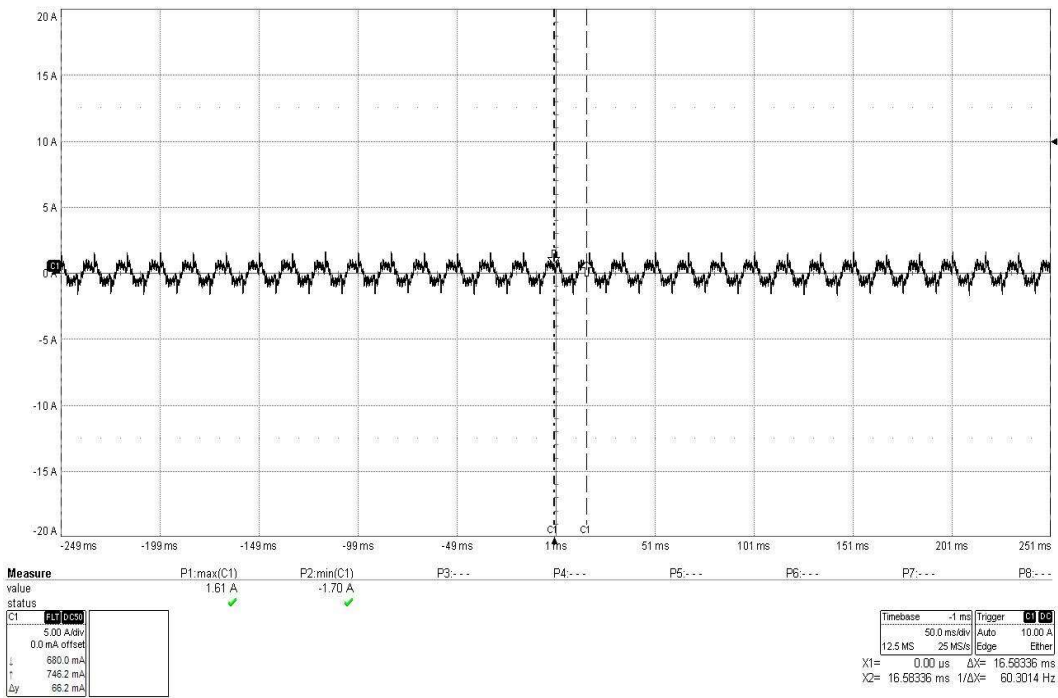

Actual CS116 Damped Sinusoidal Transient Test at 1 MHz on AC L1

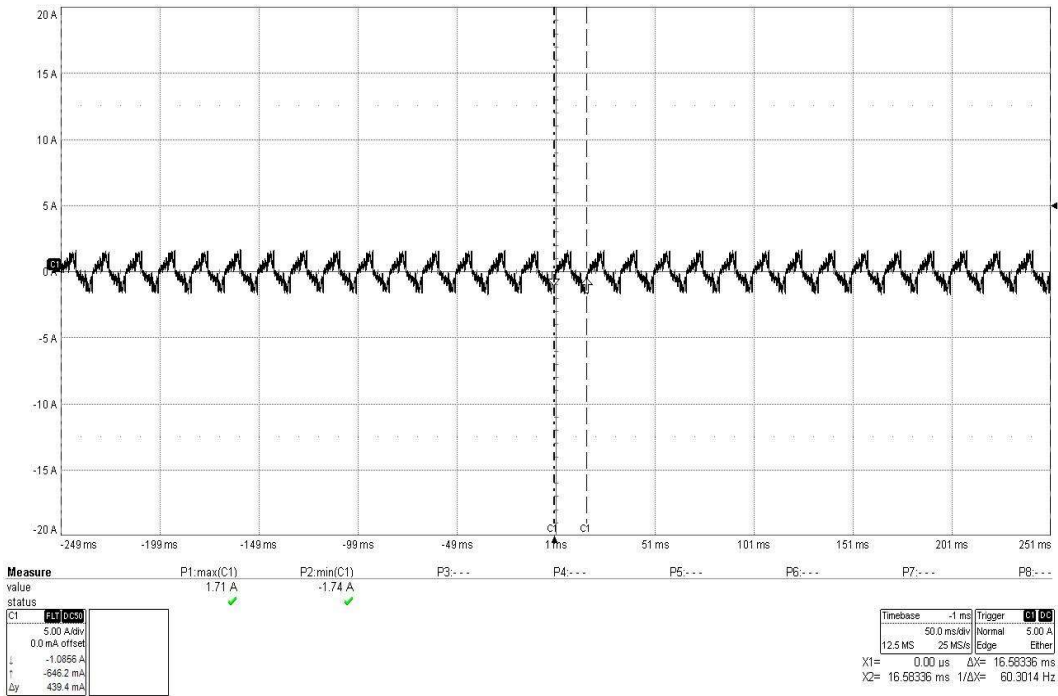

Actual CS116 Damped Sinusoidal Transient Test at 1 MHz on AC L2

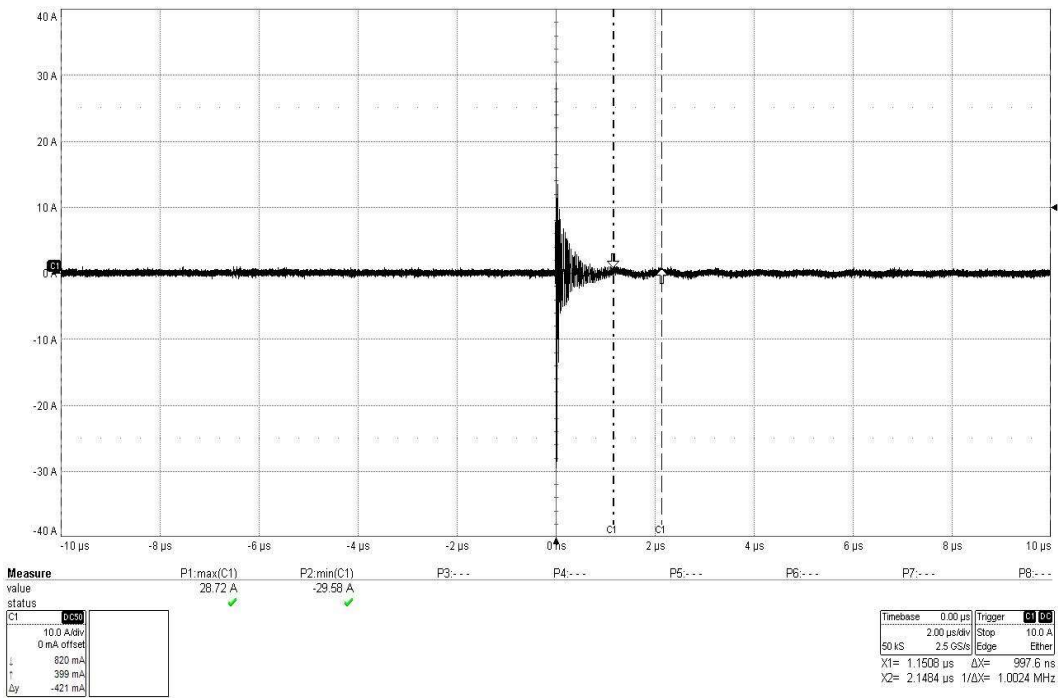

Actual CS116 Damped Sinusoidal Transient Test at 1 MHz on DC Bundle

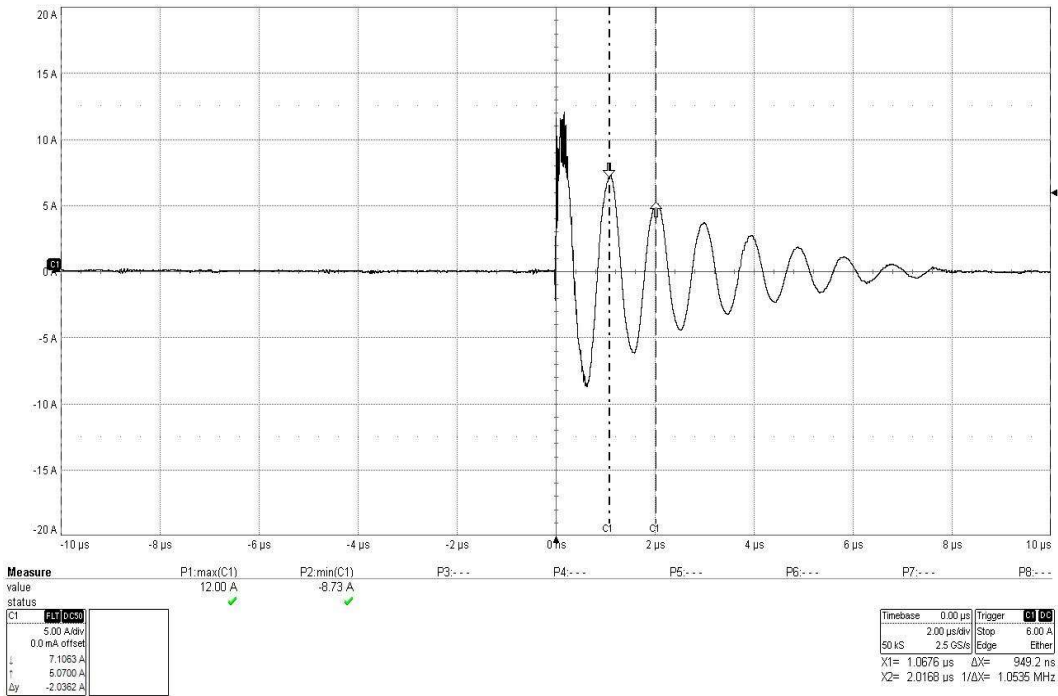

Actual CS116 Damped Sinusoidal Transient Test at 1 MHz on DC High Side

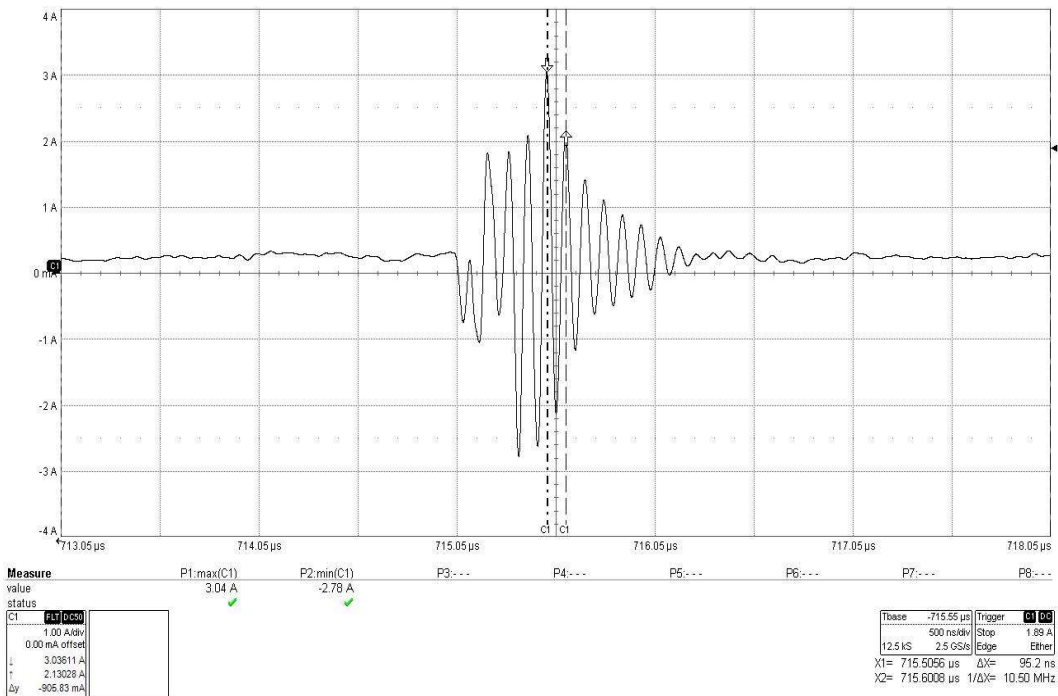

Actual CS116 Damped Sinusoidal Transient Test at 10 MHz on AC Bundle

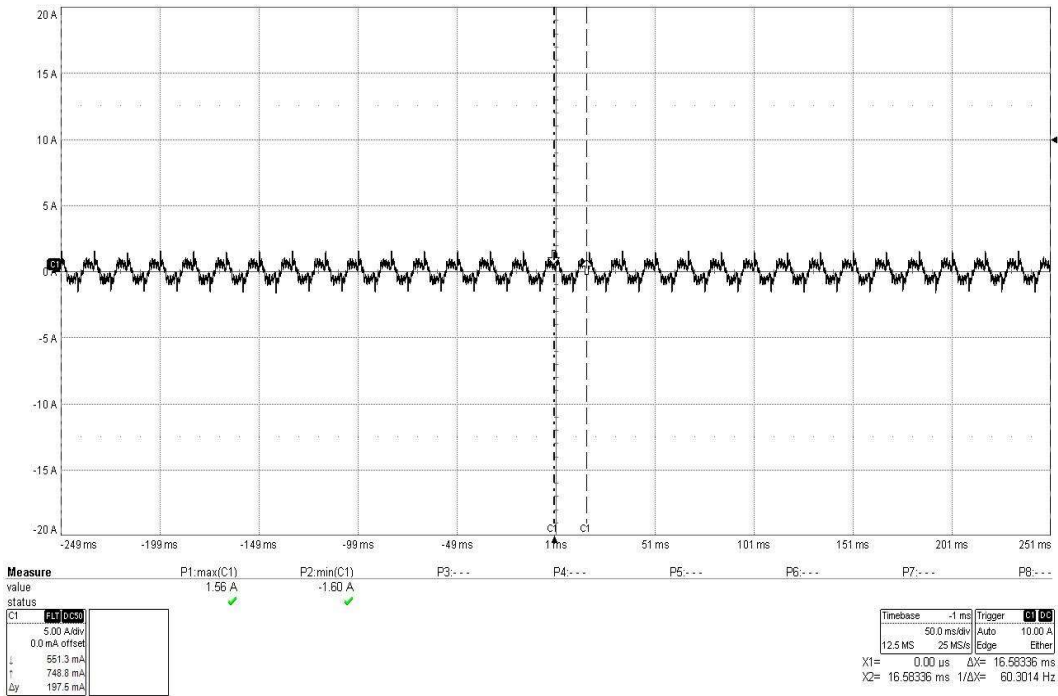

Actual CS116 Damped Sinusoidal Transient Test at 10 MHz on AC L1

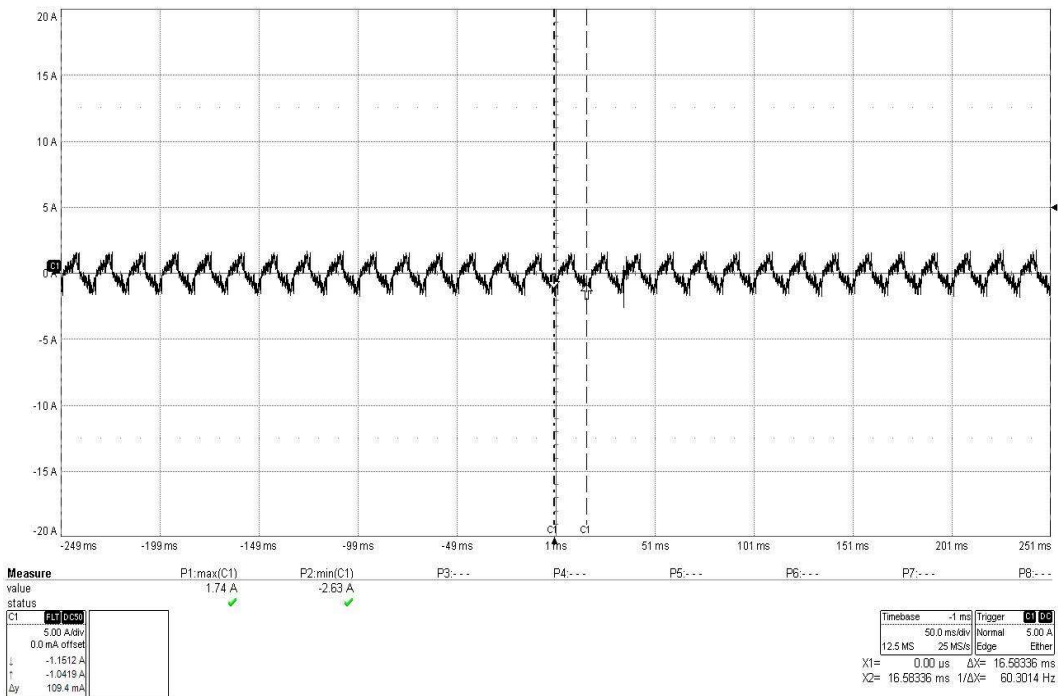

Actual CS116 Damped Sinusoidal Transient Test at 10 MHz on AC L2

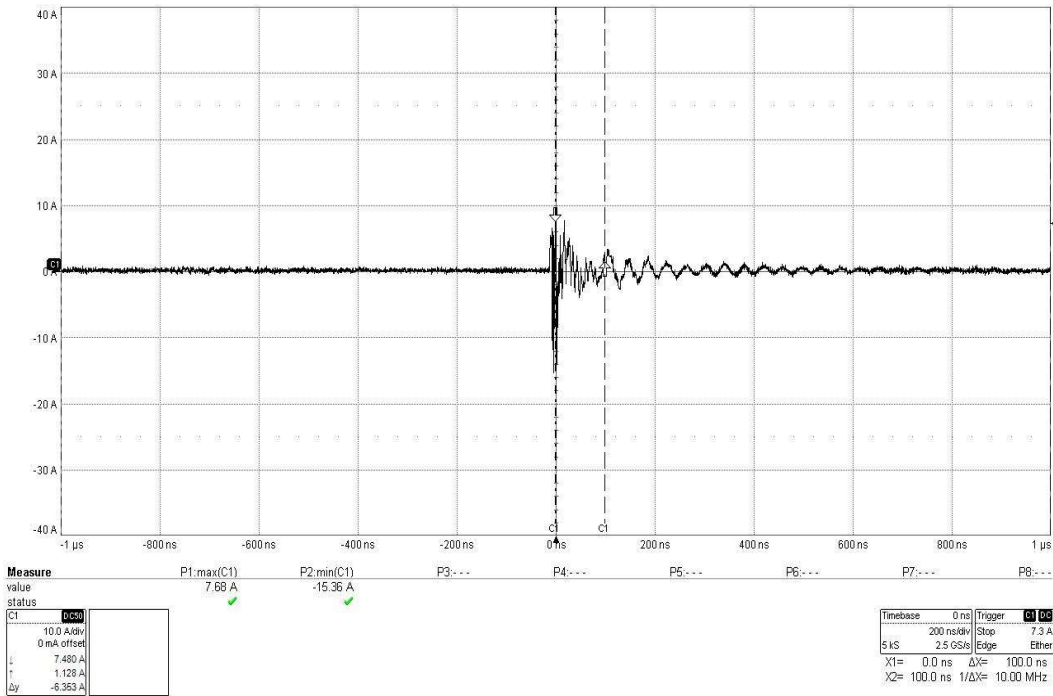

Actual CS116 Damped Sinusoidal Transient Test at 10 MHz on DC Bundle

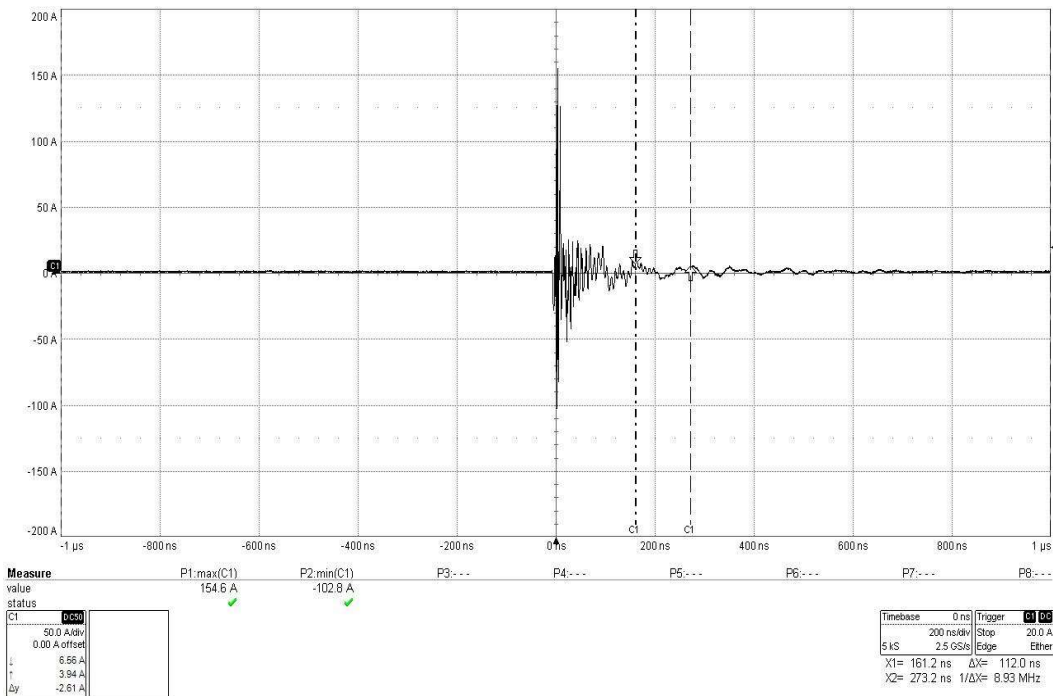

Actual CS116 Damped Sinusoidal Transient Test at 10 MHz on DC High Side

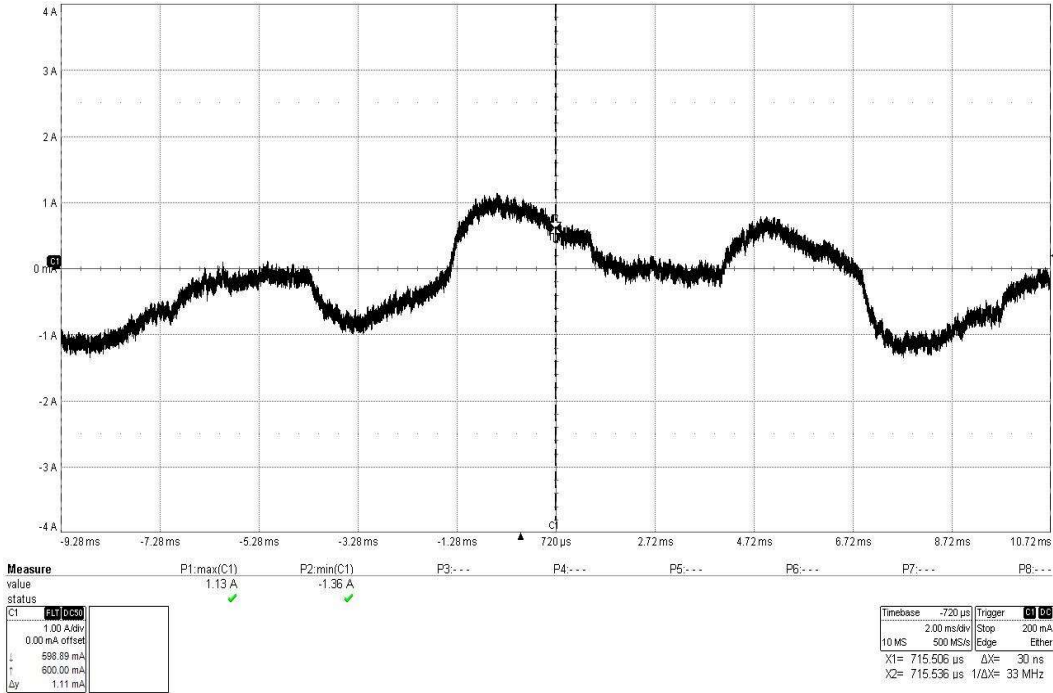

Actual CS116 Damped Sinusoidal Transient Test at 30 MHz on AC Bundle

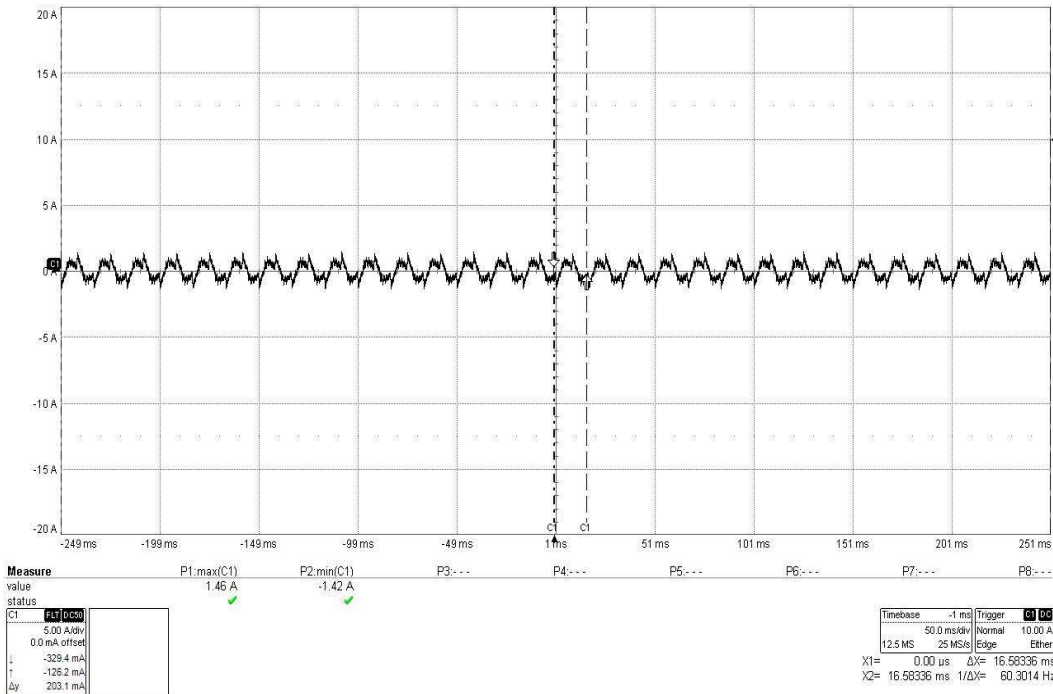

Actual CS116 Damped Sinusoidal Transient Test at 30 MHz on AC L1

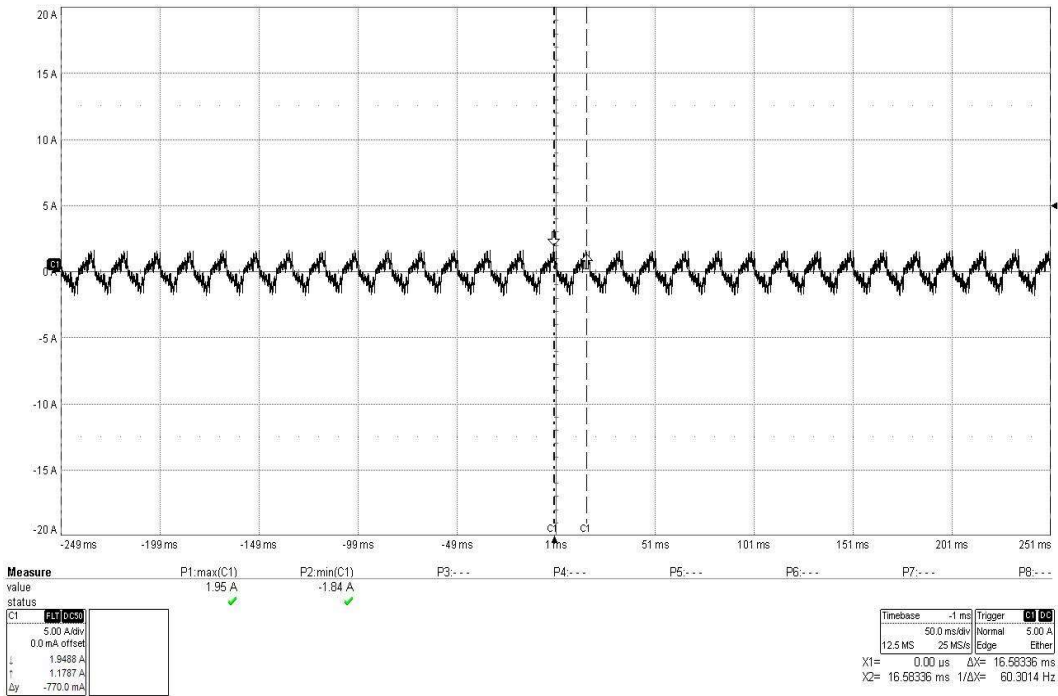

Actual CS116 Damped Sinusoidal Transient Test at 30 MHz on AC L2

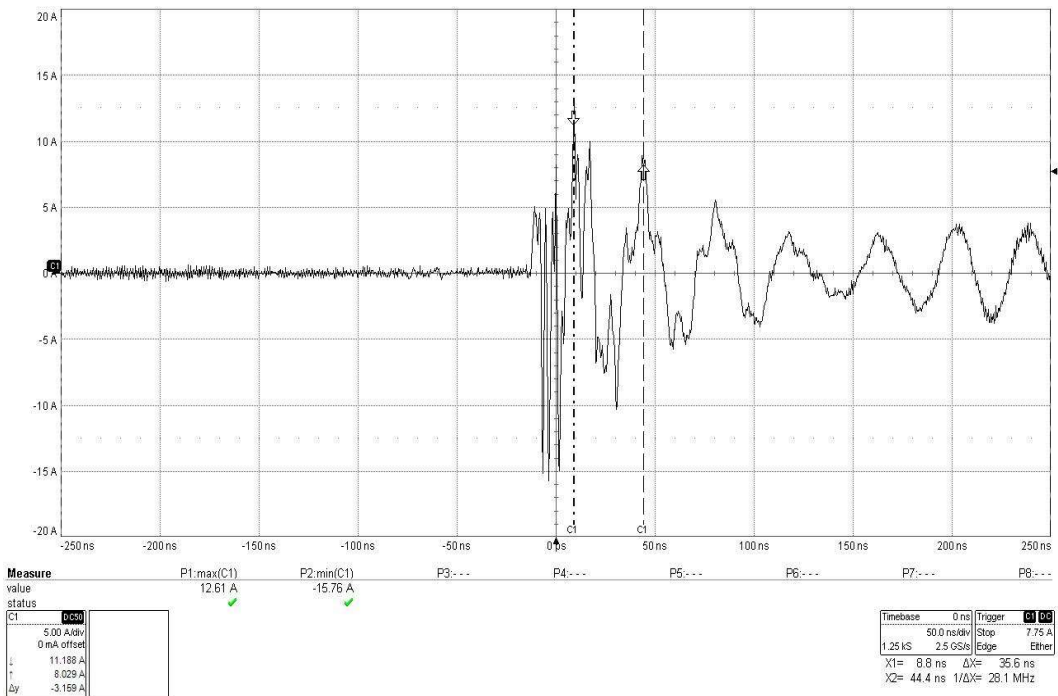

Actual CS116 Damped Sinusoidal Transient Test at 30 MHz on DC Bundle

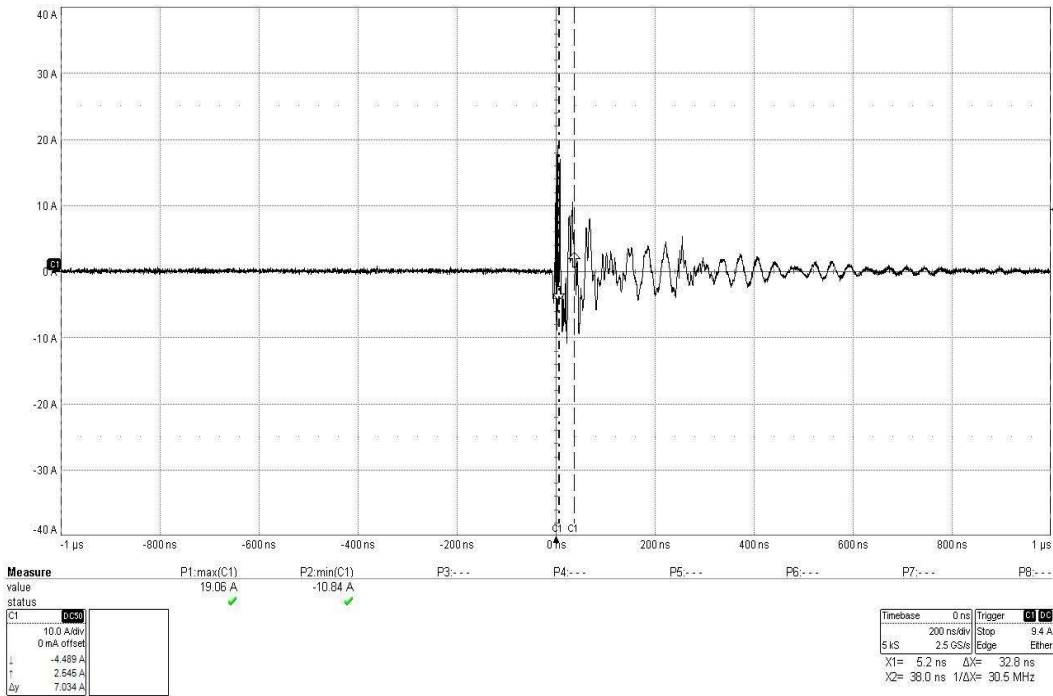

Actual CS116 Damped Sinusoidal Transient Test at 30 MHz on DC High Side

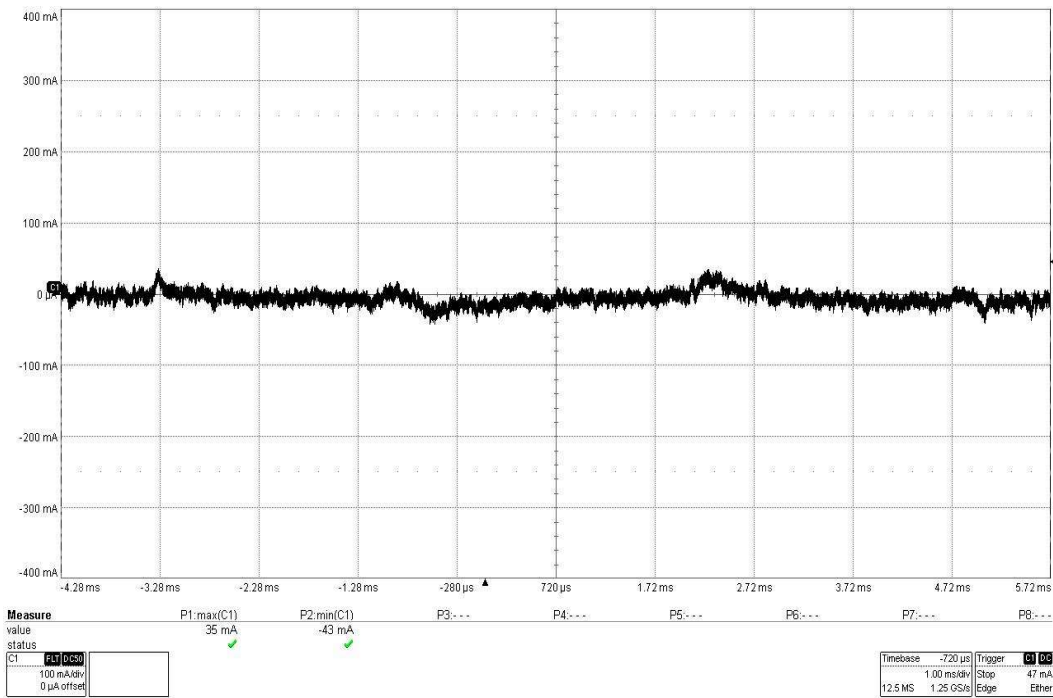

Actual CS116 Damped Sinusoidal Transient Test at 100 MHz on AC Bundle

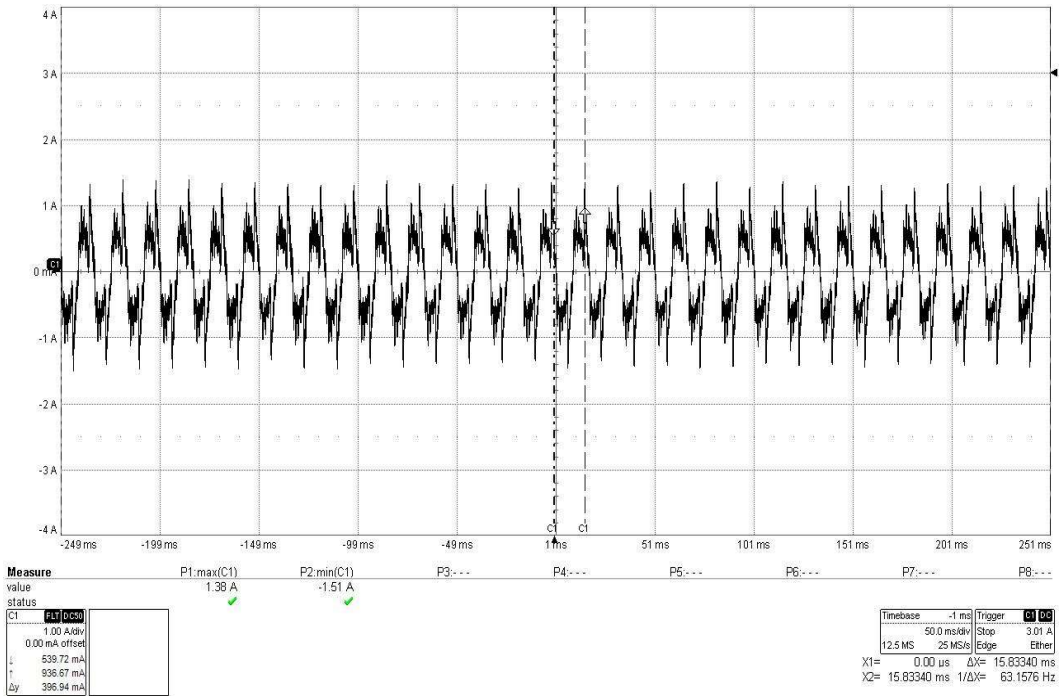

Actual CS116 Damped Sinusoidal Transient Test at 100 MHz on AC L1

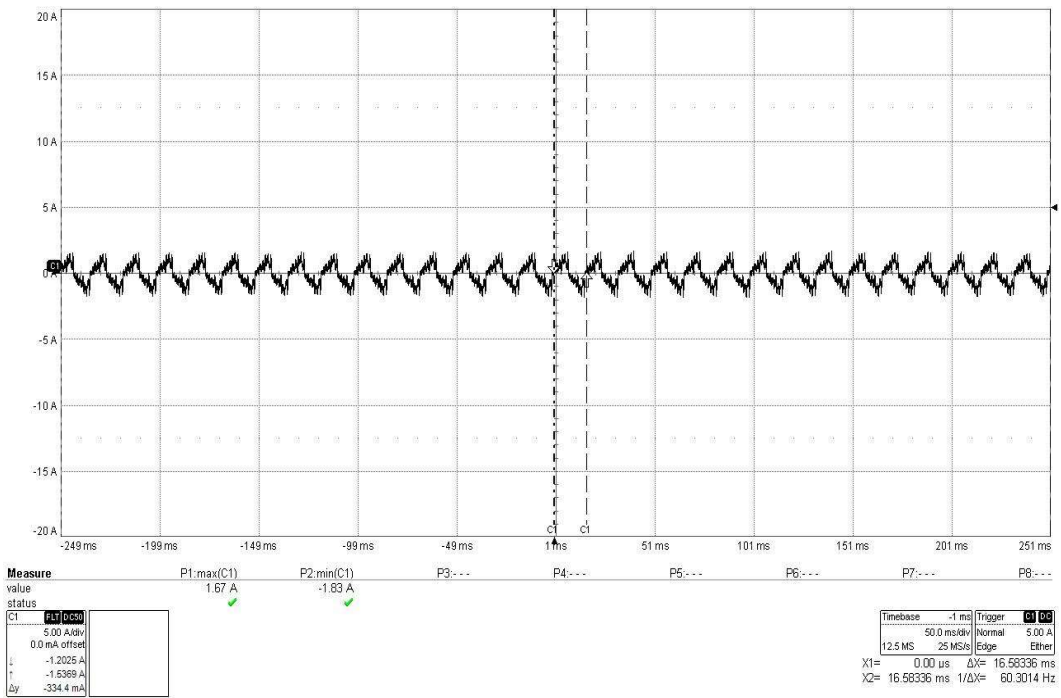

Actual CS116 Damped Sinusoidal Transient Test at 100 MHz on AC L2

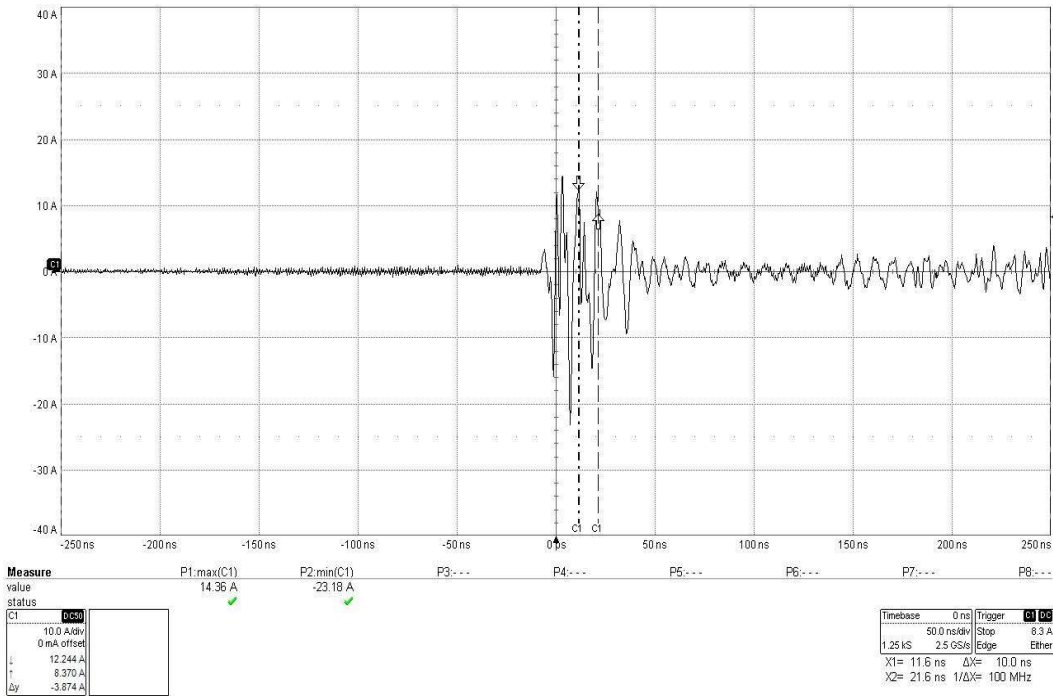

Actual CS116 Damped Sinusoidal Transient Test at 100 MHz on DC Bundle

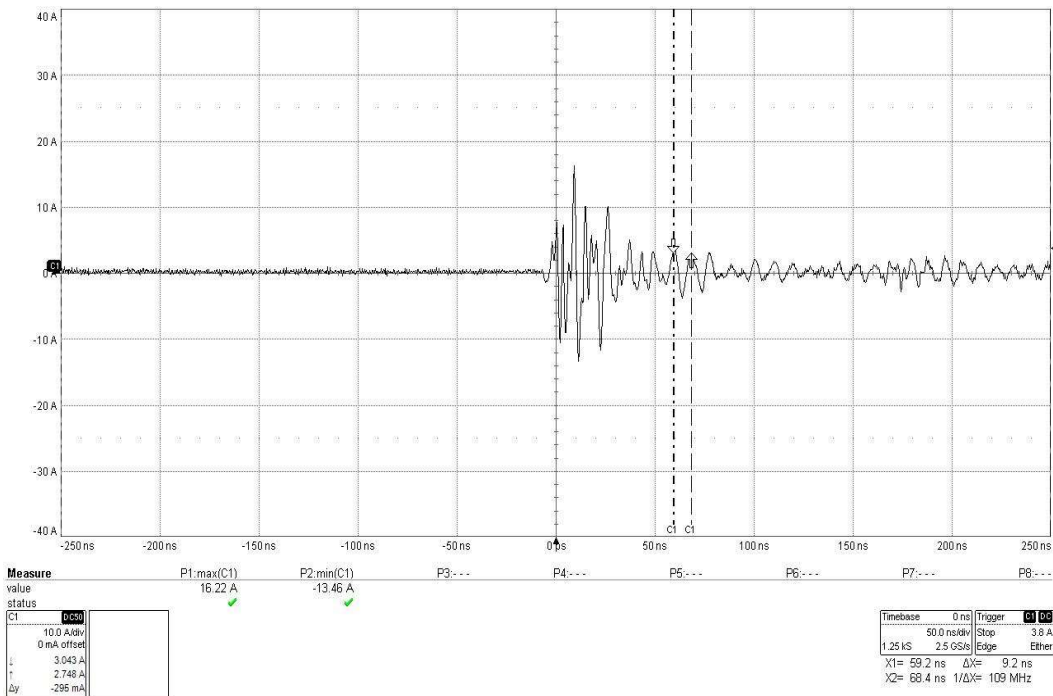

Actual CS116 Damped Sinusoidal Transient Test at 100 MHz on DC High Side

5.2.9 CS116 Test Equipment

CS116 Conducted Susceptibility, Damped Sinusoidal Transients Test Equipment List			
Element ID#	Manufacturer/ Description	Duration	Cal Due
WC038473	Teledyne Lecroy, 1GHz High Definition Oscilloscope, Model: HDO4104, 2.5GS/s	12 months	1/16/2025
WC021715	Transient Pulse Generator, 150A, 300V	NCR	NA
WC021267	Solar Electronics, Current Injection Probe, Type: 9142-1N, 2MHz-450MHz, 100W	NCR	NA
WC021043	Pearson Monitor (Current), 1000X, Model 5664, SN# 081309	12 months	3/20/2025
WC066513	High Voltage Attenuator	NCR	NA
WC020926	Solar Electronics, Calibration Fixture, Type: 9125-1	NCR	NA
WC020992	Termaline Model 8135 50Hm Resistive Load	NCR	NA
WC021042	Solar Electronics, Current Injection Probe, Type: 9144-A, 10kHz-100MHz, 100W	NCR	NA
WC083001	Centric RF 10dB, 18GHz 25Watt, Coaxial Attenuator	NCR	NA
WC021313	Solar Network (LISN) 8028-50-TS-24-BNC 10 kHz to 50 MHz	12 months	4/11/2025
WC021338	Solar LISN, 8028-50-TS-24BNC, Above 20MHz	12 months	11/20/2024

Calibration Abbreviation

NCR: No Calibration Required

NA: Not Applicable

5.3 Conducted Susceptibility: Method CS117 Lightning Induced Transients, Cables and Power Leads

5.3.1 CS117 Purpose

This test procedure is used to verify the ability of the EUT to withstand lightning transients coupled onto EUT associated cables and power leads.

5.3.2 CS117 Limits

The EUT shall not exhibit any malfunction, degradation of performance, or deviation from specified indications, beyond the tolerances indicated in the individual equipment or subsystem specification, when subjected to the levels and lightning transients specified in Table VII and supplemented by the waveform and timing definitions shown on Figures CS117-1 through CS117-8. The applicable transients of Table VII are considered default values and waveforms based upon previous experience and shall be used for the defined equipment functionality when the host platform lightning transient data does not exist. In the event that there is platform lightning transient data available, this data may be used to tailor the requirements with different selected levels or waveforms, pending approval by the procuring activity. Note that the power lines are tested separately as well as within the bundle as defined in the test procedures section and are tested at the levels defined in Table VII.

5.3.3 CS117 Test Equipment

The test equipment shall be as follows:

- a. Lightning transient generator
- b. Injection Transformers
- c. Oscilloscope
- d. Current monitor probes
- e. Attenuators, 50 ohm, as needed on current monitor probes
- f. Voltage monitor probes, high impedance
- g. Monitor loop, low impedance wire loop
- h. Calibration loop, low impedance wire loop
- i. Capacitors, $\geq 28,000 \mu\text{F}$ for DC power inputs and $10 \mu\text{F}$ for AC power inputs
- j. LISNs

5.3.4 CS117 Test Setup

The test setup shall be as follows:

- a. Maintain a basic test setup for the EUT as shown and described on Figures 2 through 5 and section 4.3.8 of the MIL-STD-461G. The power input side of the LISN shall have a $\geq 28,000 \mu\text{F}$ capacitor between the high and return for DC power and a $10 \mu\text{F}$ capacitor from high and return to ground plane for AC power.
- b. Calibration. Configure the test equipment in accordance with Figure CS117-9 for verification of the waveform, both short circuit current and open circuit voltage.
- c. EUT testing:
 - (1) Configure the test equipment as shown on Figure CS117-10, Figure CS117-11 or Figure CS117-12.
 - (2) Place the injection transformer and current monitor probe(s) around a cable bundle interfacing an EUT connector.
 - (3) Locate the current monitor probe 5-15 cm from the connector. If the overall length of the connector and backshell exceeds 15 cm, position the current monitor probe as close to the connector's backshell as possible.
 - (4) Position the injection transformer 5-50 cm from the current monitor probe.
 - (5) Place a monitor loop in the injection transformer and connect a voltage monitor probe.

5.3.5 CS117 Test Procedure

The test procedures shall be as follows:

- a. Turn on the measurement equipment and allow sufficient time for stabilization.
- b. Calibration. Perform the following procedures using the calibration setup for waveform verification.

- (1) Connect the transient generator to the primary input of the injection transformer.
- (2) For each waveform, at the designated test level (VT or IT), record the voltage waveform with the calibration loop open or the current waveform with the calibration loop shorted, as applicable. Verify that each waveform complies with the relevant waveshape parameters shown on Figure CS117-1 through Figure CS117-6. It is not necessary for the transient generator to produce the associated voltage or current limit level (VL or IL) and waveshape. However, if the transient generator is capable of reaching the designated limit level (VL or IL), record and verify the limit waveform at that generator setting.
- (3) For the Multiple Stroke and Multiple Burst tests, also verify the applicable pulse patterns and timing identified on Figure CS117-7 and Figure CS117-8.
- (4) Reverse the transient generator polarity and repeat 5.9.5b(2) through 5.9.5b(3).

- c. EUT testing.

- (1) Turn on the EUT and measurement equipment to allow sufficient time for stabilization.
- (2) While applying transients, increase the generator setting until the designated test level (VT or IT) or the limit level (VL or IL) is reached. Adjustments shall be made in the generator settings and/or injection transformer configuration as necessary to enable the required test level (VT or IT) to be achieved in the tested cable unless the corresponding limit level (VL or IL) is reached first. Calibration shall then be repeated if changes are made to the injection transformer configuration. Record the waveforms and amplitude levels obtained. If the limit level (VL or IL) is reached before the test level (VT or IT), the test shall be reevaluated to determine if the test is acceptable as follows:
 - (a) If the transient generator produced a compliant limit waveform (amplitude and waveshape) during calibration, the test is acceptable.
 - (b) If the specified limit waveform is achieved during the test and is within the waveshape tolerances shown on Figure CS117-1 through Figure CS117-6, the test is acceptable.
 - (c) If one of the above criteria is not met, then the test shall be repeated for that cable bundle using another transient generator that can meet the limit waveform requirements. In this case, the associated limit level (VL or IL) now becomes the test level (VT or IT) and the test level now becomes the limit level. Calibration shall be repeated using the substitute transient generator.

When measuring voltage or current waveform levels, short duration spikes or high frequency noise due to instrument noise, switching transients, or loading effects shall be ignored.

- (3) For the Multiple Stroke test, at the generator setting established in 5.9.5c(2), apply a minimum of ten multiple stroke applications while monitoring the operation of the EUT. The maximum time between application of each Multiple Stroke transient shall be no greater than 5 minutes.
- (4) For the Multiple Burst test, at the generator setting established in 5.9.5c(2), apply a multiple burst application every 3 seconds (3 seconds between the start of each set of three bursts) continuously for a minimum of 5 minutes.
- (5) Reverse the transient generator polarity and repeat 5.9.5c(2) through 5.9.5c(4).
- (6) Repeat 5.9.5c(2) through 5.9.5c(5) on each cable bundle interfacing with each electrical connector on the EUT. For power cables, perform 5.9.5c(2) through 5.9.5c(5) on complete power cables (high sides and returns) and on the power cables with the power returns and chassis grounds (green wires) excluded from the cable bundle. For connectors which include both interconnecting leads and power, perform 5.9.5c(2) through 5.9.5c(5) on the entire bundle, on the power leads (including returns and grounds) grouped separately, and on the power leads grouped with the returns and grounds removed.

TABLE VII. CS117 Test and limit levels for multiple stroke and multiple burst lightning tests.

<u>Multiple Stroke</u>			
Applicability	Test Description	Internal Equipment Levels**	External Equipment Levels**
All equipment installations	Waveform 2 (WF2)/ Waveform 1 (WF1)	<u>First Stroke</u> $V_L = 300 \text{ V (WF2)}$ $I_T = 600 \text{ A (WF1)}$ $I_T = 60 \text{ A}^*$ <u>Subsequent Strokes</u> $V_L = 150 \text{ V (WF2)}$ $I_T = 150 \text{ A (WF1)}$ $I_T = 30 \text{ A}^*$	<u>First Stroke</u> $V_L = 750 \text{ V (WF2)}$ $I_T = 1500 \text{ A (WF1)}$ $I_T = 150 \text{ A}^*$ <u>Subsequent Strokes</u> $V_L = 375 \text{ V (WF2)}$ $I_T = 375 \text{ A (WF1)}$ $I_T = 75 \text{ A}^*$
All equipment installations	Waveform 3 (WF3) – 1 MHz and 10 MHz	<u>First Stroke</u> $V_T = 600 \text{ V (WF3)}$ $I_L = 120 \text{ A (WF3)}$ $I_L = 24 \text{ A}^*$ <u>Subsequent Strokes</u> $V_T = 300 \text{ V (WF3)}$ $I_L = 60 \text{ A (WF3)}$ $I_L = 12 \text{ A}^*$	<u>First Stroke</u> $V_T = 1500 \text{ V (WF3)}$ $I_L = 300 \text{ A (WF3)}$ $I_L = 60 \text{ A}^*$ <u>Subsequent Strokes</u> $V_T = 750 \text{ V (WF3)}$ $I_L = 150 \text{ A (WF3)}$ $I_L = 30 \text{ A}^*$
Equipment installations routed in areas with composite skin/structure.	Waveform 4 (WF4)/ Waveform 5A (WF5A)	<u>First Stroke</u> $V_L = 300 \text{ V (WF4)}$ $I_T = 1000 \text{ A (WF5A)}$ $I_T = 300 \text{ A}^*$ <u>Subsequent Strokes</u> $V_L = 75 \text{ V (WF4)}$ $I_T = 200 \text{ A (WF5A)}$ $I_T = 150 \text{ A}^*$	<u>First Stroke</u> $V_L = 750 \text{ V (WF4)}$ $I_T = 2000 \text{ A (WF5A)}$ $I_T = 750 \text{ A}^*$ <u>Subsequent Strokes</u> $V_L = 187.5 \text{ V (WF4)}$ $I_T = 400 \text{ A (WF5A)}$ $I_T = 375 \text{ A}^*$
<u>Multiple Burst</u>			
Applicability	Test Description	Internal Equipment Levels**	External Equipment Levels**
All equipment installations	Waveform 3 (WF3) – 1 MHz and 10 MHz	$V_T = 360 \text{ V (WF3)}$ $I_L = 6 \text{ A (WF3)}$	$V_T = 900 \text{ V (WF3)}$ $I_L = 15 \text{ A (WF3)}$
Equipment installations that utilize short, low impedance cable bundle installations.	Waveform 6 (WF6)	$V_L = 600 \text{ V (WF6)}$ $I_T = 30 \text{ A (WF6)}$	$V_L = 1500 \text{ V (WF6)}$ $I_T = 75 \text{ A (WF6)}$
Notes: *These current levels are intended for individual power leads or low count wire bundles. When multiple leads are tested together, this current shall be increased to the full bundle level or to the number of leads multiplied by the appropriate individual current test or limit level, whichever is less. **Amplitude Tolerance is +20%,-0% for all waveforms, except the tolerance is relaxed to +50%,-0% for the Subsequent Strokes. V_T represents the test voltage level in volts and I_T represents the test current level in amperes. V_L (volts) and I_L (amperes) represent limits intended to prevent over-stressing the EUT beyond the requirements.			

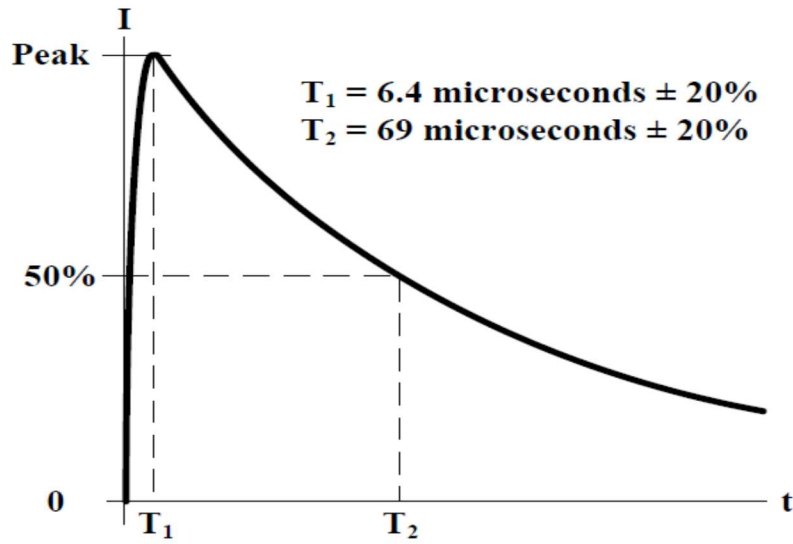

Figure CS117-1 Current Waveform 1

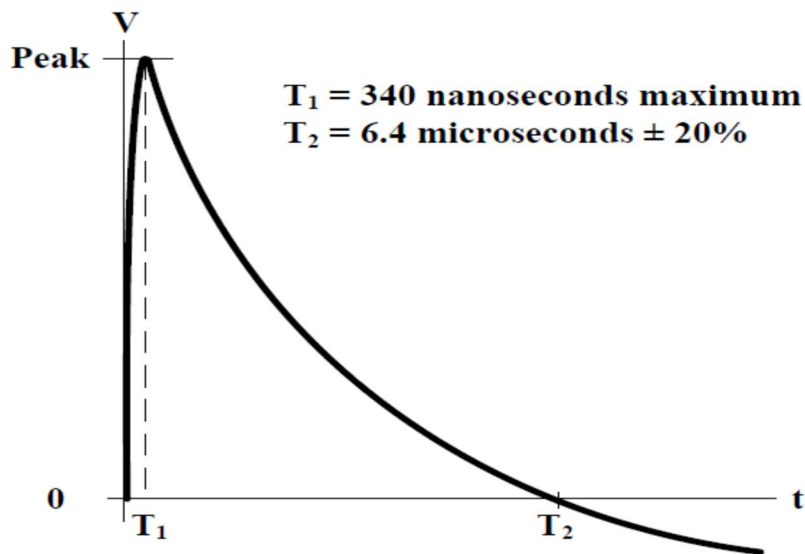
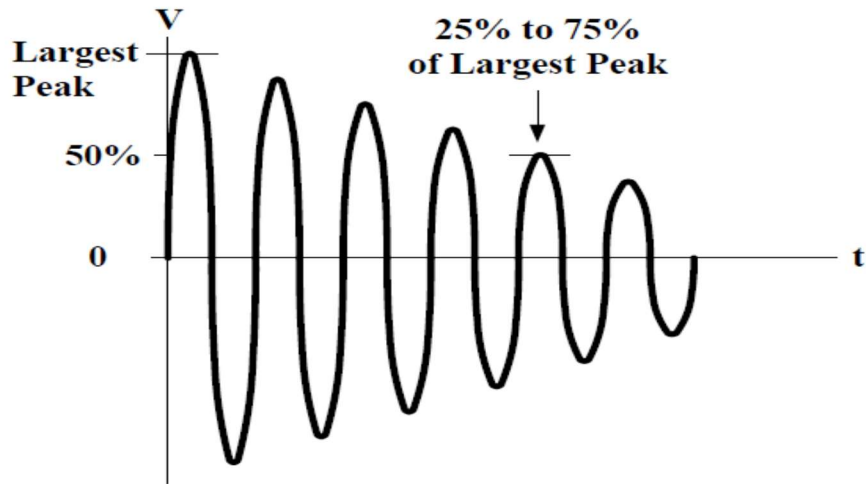

Figure CS117-2 Voltage Waveform 2



NOTE:
The waveshape may have either a damped sine or cosine waveshape.

Figure CS117-3 Voltage Waveform 3

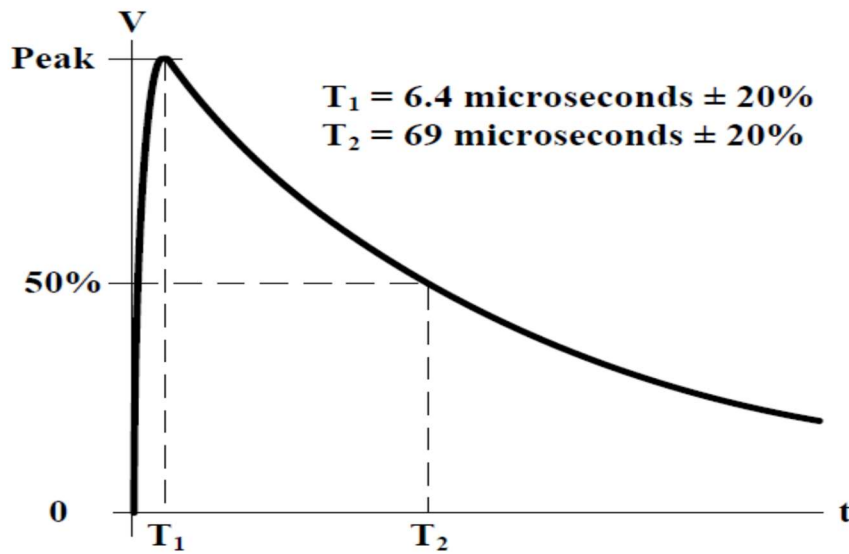

Figure CS117-4 Voltage Waveform 4

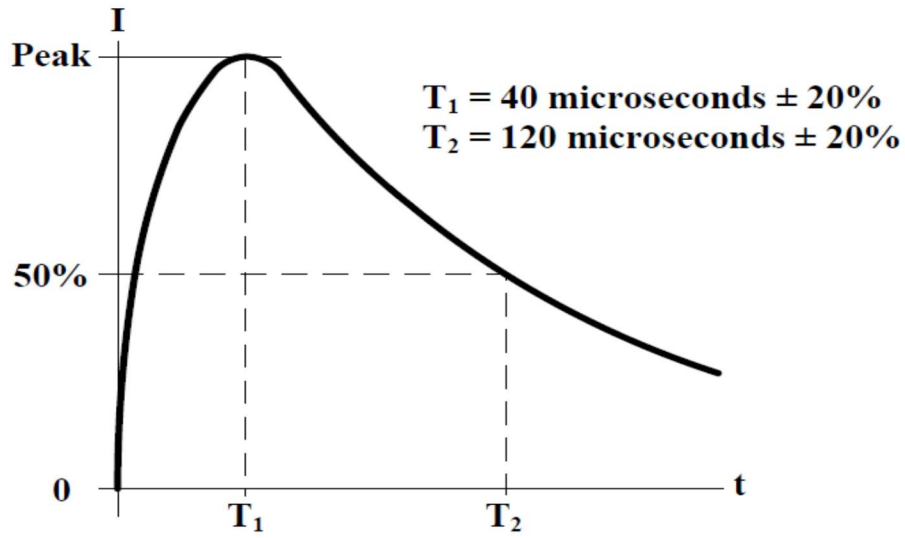

Figure CS117-5 Current Waveform 5A

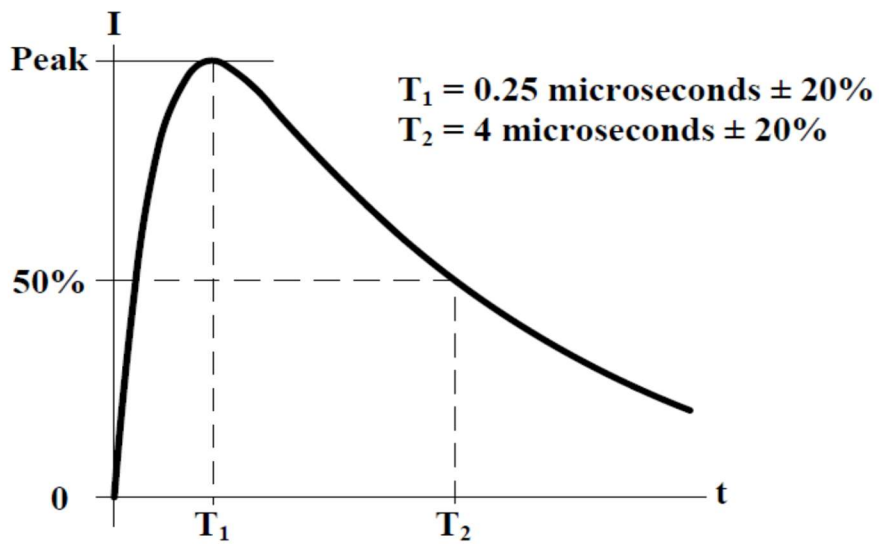

Figure CS117-6 Current Waveform 6

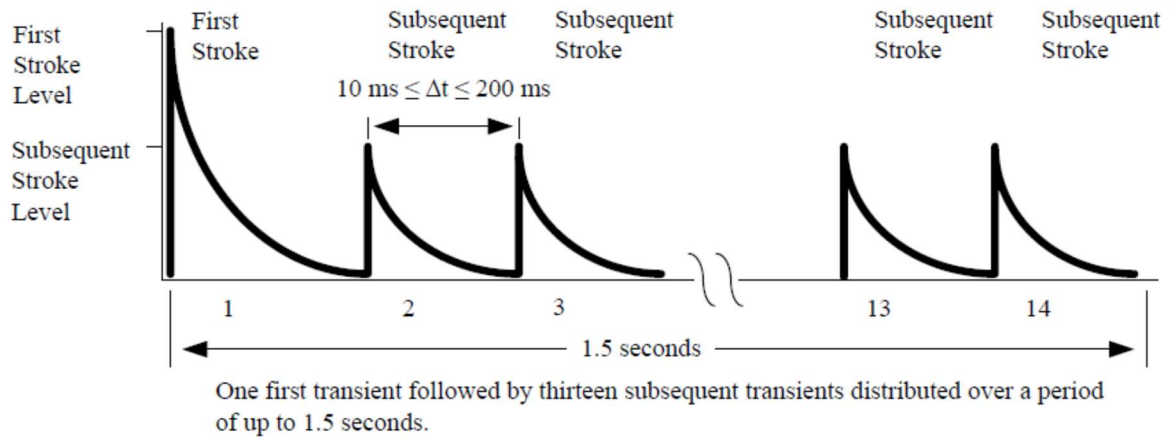

Figure CS117-7 Multiple Stroke Application

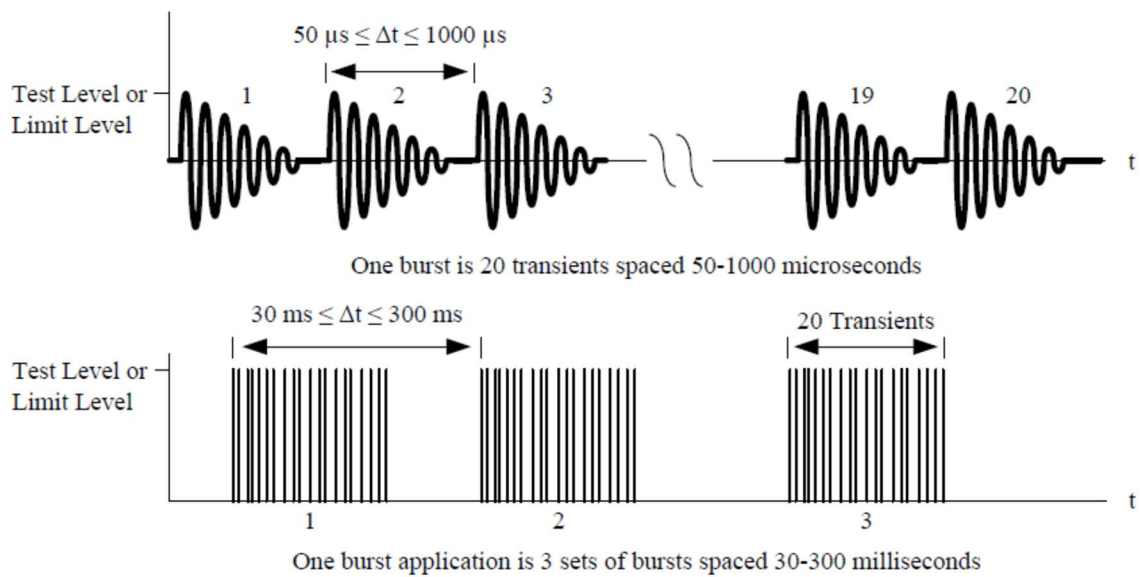

Figure CS117-8 Multiple Burst Application

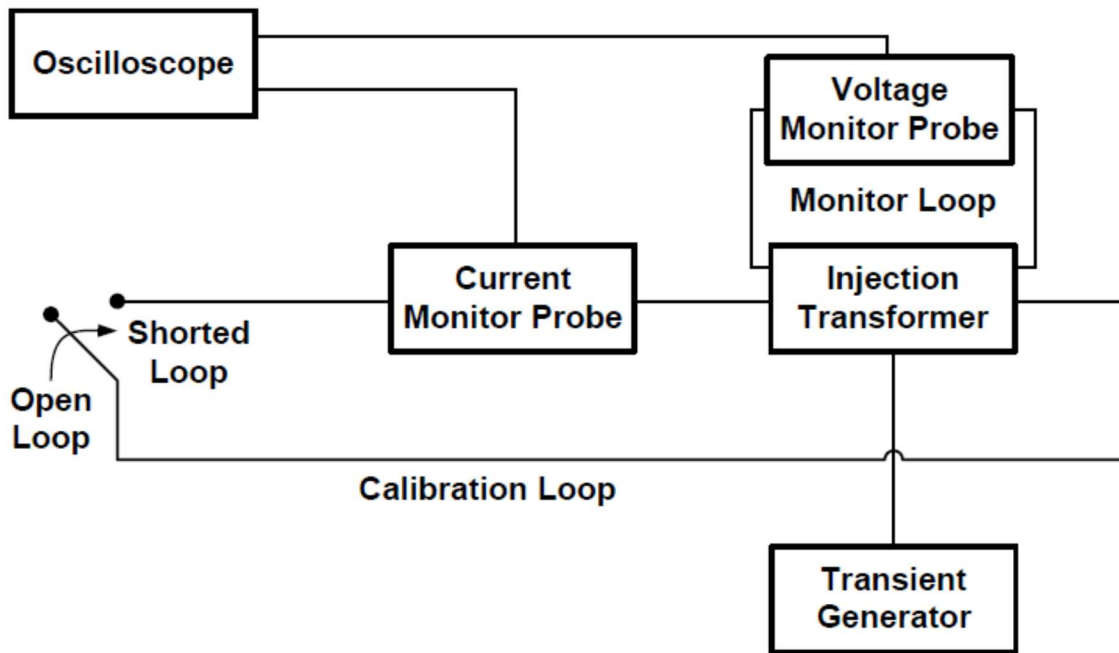

Figure CS117-9 Typical test setup for calibration of lightning waveforms

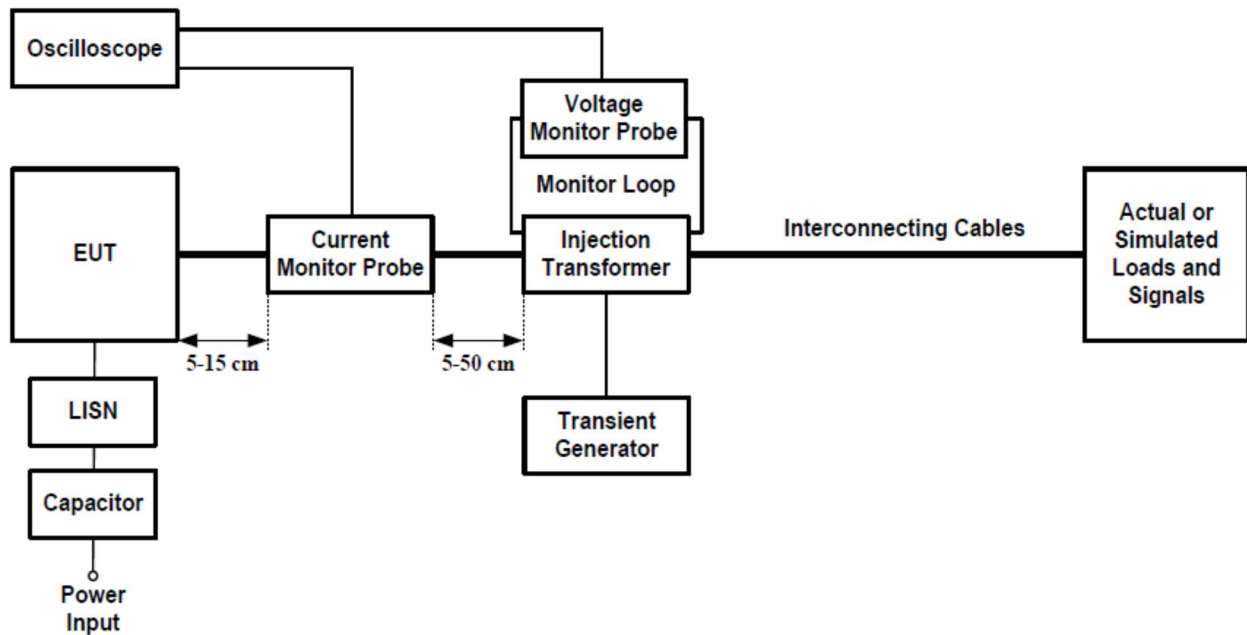

Figure CS117-10 Typical setup for bulk cable injection of lightning transients on complete interconnecting cable bundles

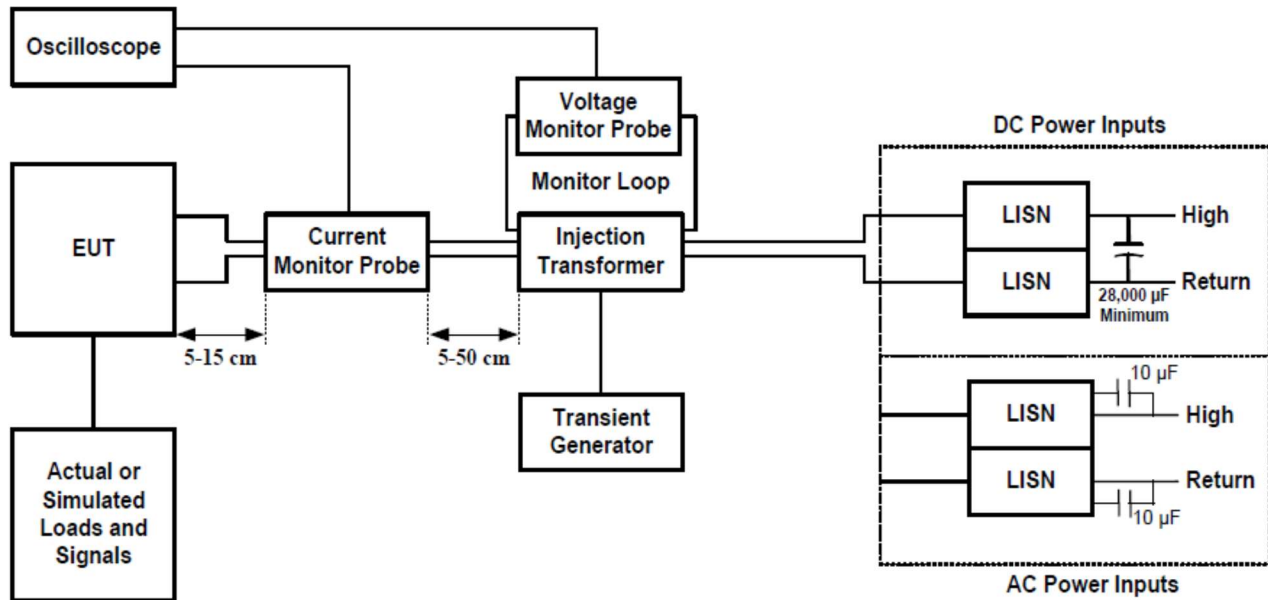

Figure CS117-11 Typical setup for bulk cable injection of lightning transients on complete power cables (high sides and returns)

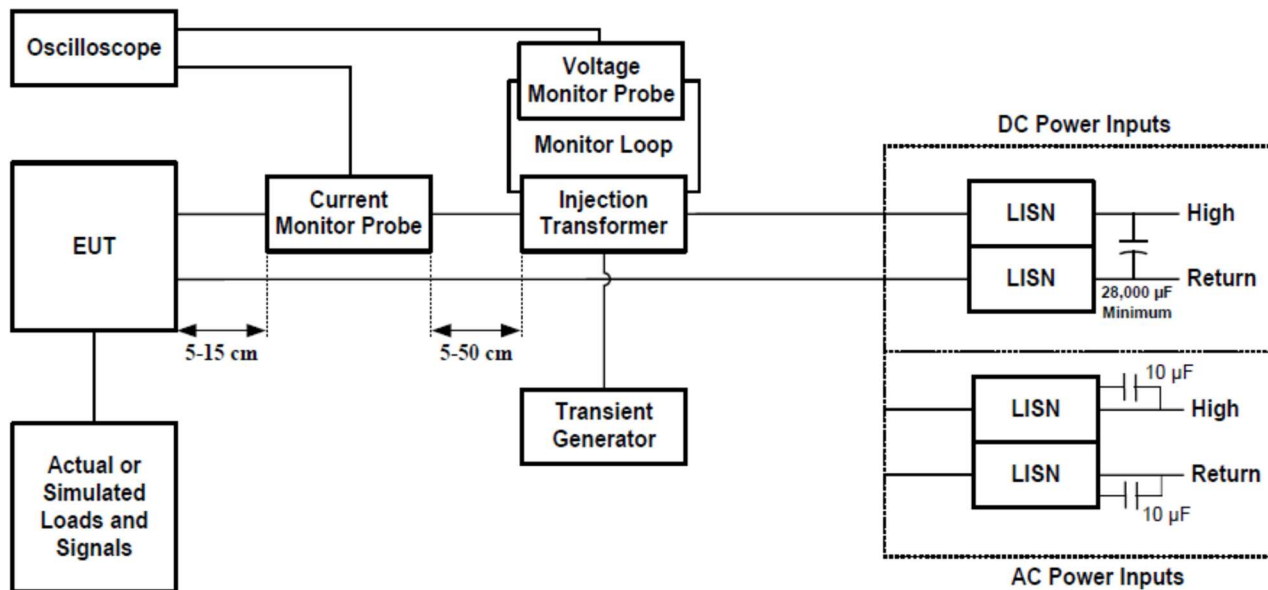

Figure CS117-12 Typical setup for bulk cable injection of lightning transients on power cables with power returns and chassis grounds excluded from the cable bundle

5.3.6 CS117 Test Results

The EUT **complied** with the requirements.

5.3.7 CS117 Test Photographs



General Test Setup for CS117, General Test Setup for Waveform #1



General Test Setup for CS117, General Test Setup for Waveform #1 – Open Circuit



General Test Setup for CS117, General Test Setup for Waveform #1 – Short Circuit



General Test Setup for CS117, General Test Setup for Waveform #3



General Test Setup for CS117, General Test Setup for Waveform #3 – Open Circuit



General Test Setup for CS117, General Test Setup for Waveform #3 – Short Circuit

Actual Test Photographs for Inverter



Test Setup for CS117, General Waveform #1 Test Setup for Inverter



Test Setup for CS117, Actual Test Waveform #1 on AC Bundle



Test Setup for CS117, Actual Test Waveform #1 on AC Line 1



Test Setup for CS117, Actual Test Waveform #1 on AC Line 2



Test Setup for CS117, Actual Test Waveform #1 on Battery Bundle



Test Setup for CS117, Actual Test Waveform #1 on Battery High Side



Test Setup for CS117, Actual Test Waveform #1 on Battery Return Side



Test Setup for CS117, Actual Test Waveform #1 on PV Bundle

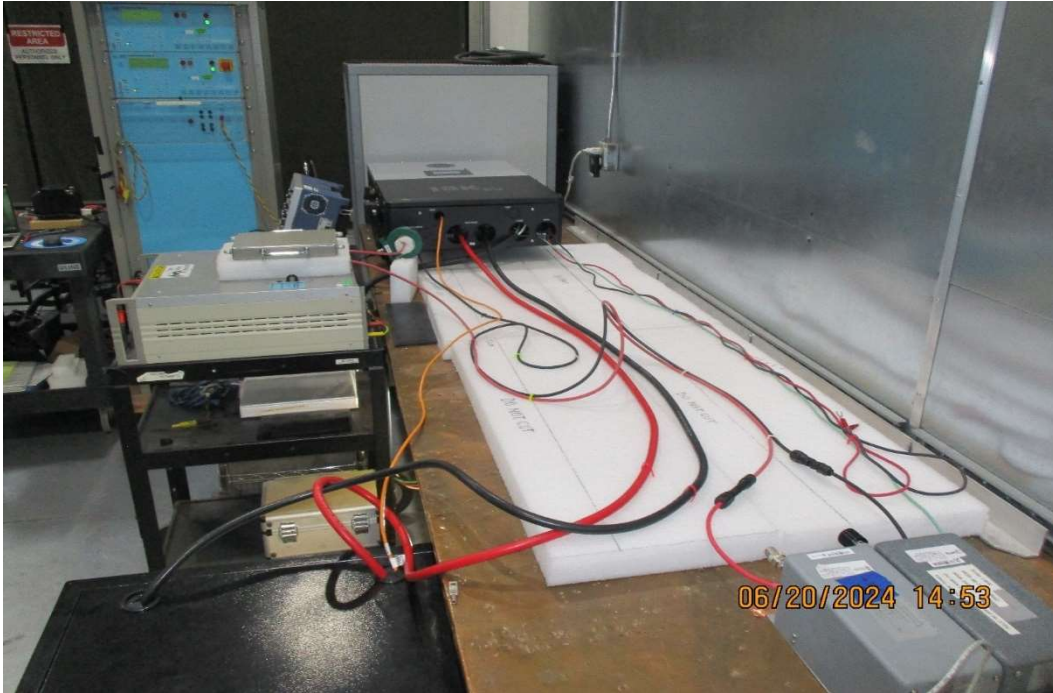

Test Setup for CS117, Actual Test Waveform #1 on PV High Side

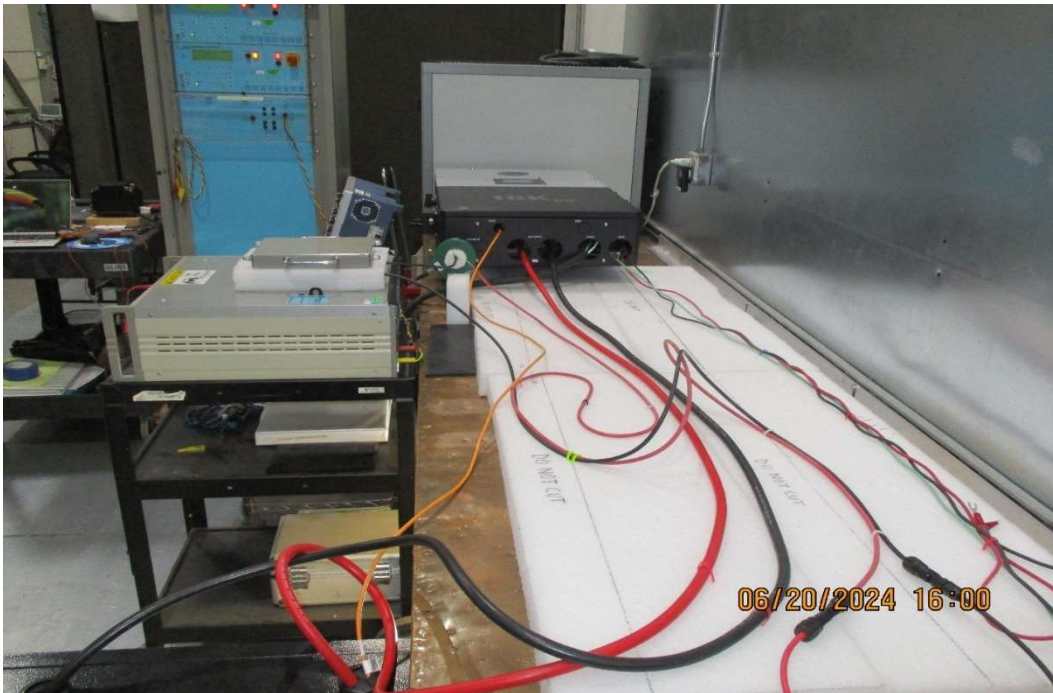

Test Setup for CS117, Actual Test Waveform #1 on PV Return Side



Test Setup for CS117, General Waveform #2 & #3 Test Setup for Inverter

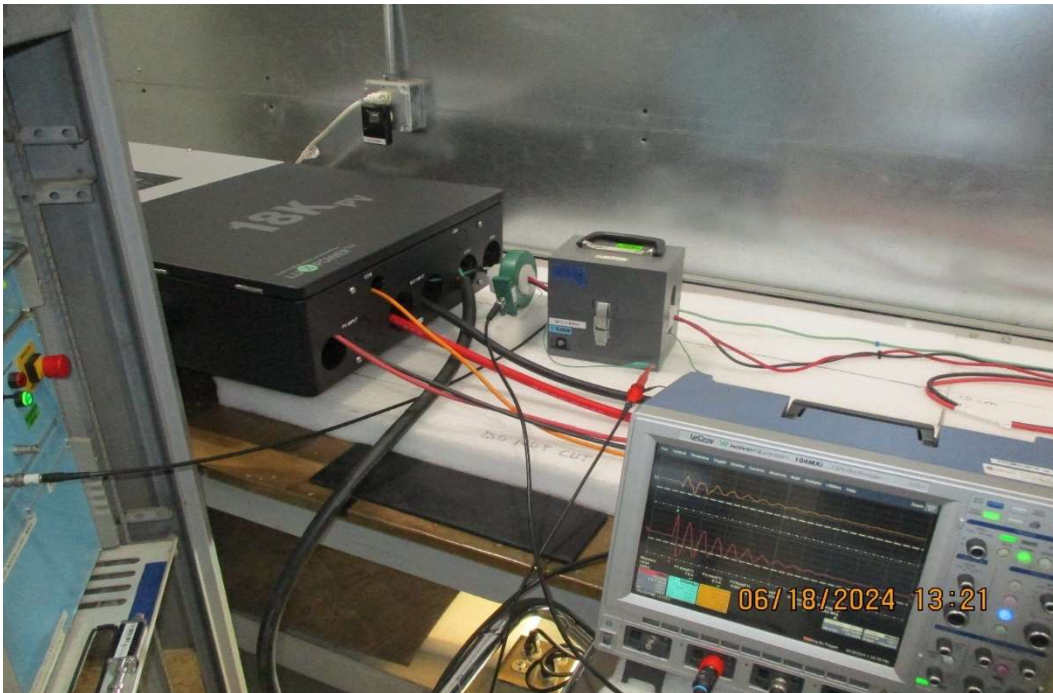

Test Setup for CS117, Actual Test Waveform #2 & #3 on AC Bundle



Test Setup for CS117, Actual Test Waveform #2 & #3 on AC Line 1



Test Setup for CS117, Actual Test Waveform #2 & #3 on AC Line 2



Test Setup for CS117, Actual Test Waveform #2 & #3 on Battery Bundle



Test Setup for CS117, Actual Test Waveform #2 & #3 on Battery High Side



Test Setup for CS117, Actual Test Waveform #2 & #3 on Battery Return Side



Test Setup for CS117, Actual Test Waveform #2 & #3 on PV Bundle



Test Setup for CS117, Actual Test Waveform #2 & #3 on PV High Side



Test Setup for CS117, Actual Test Waveform #2 & #3 on PV Return Side

Actual Test Photographs for Battery Rack Mount



Test Setup for CS117, General Waveform #1 Test Setup for Battery Rack Mount



Test Setup for CS117, Actual Test Waveform #1 on Battery High Side



Test Setup for CS117, Actual Test Waveform #1 on Battery Return Side



Test Setup for CS117, Actual Test Waveform #2 on Battery Bundle



Test Setup for CS117, General Waveform #2 & #3 Test Setup for Battery Rack Mount

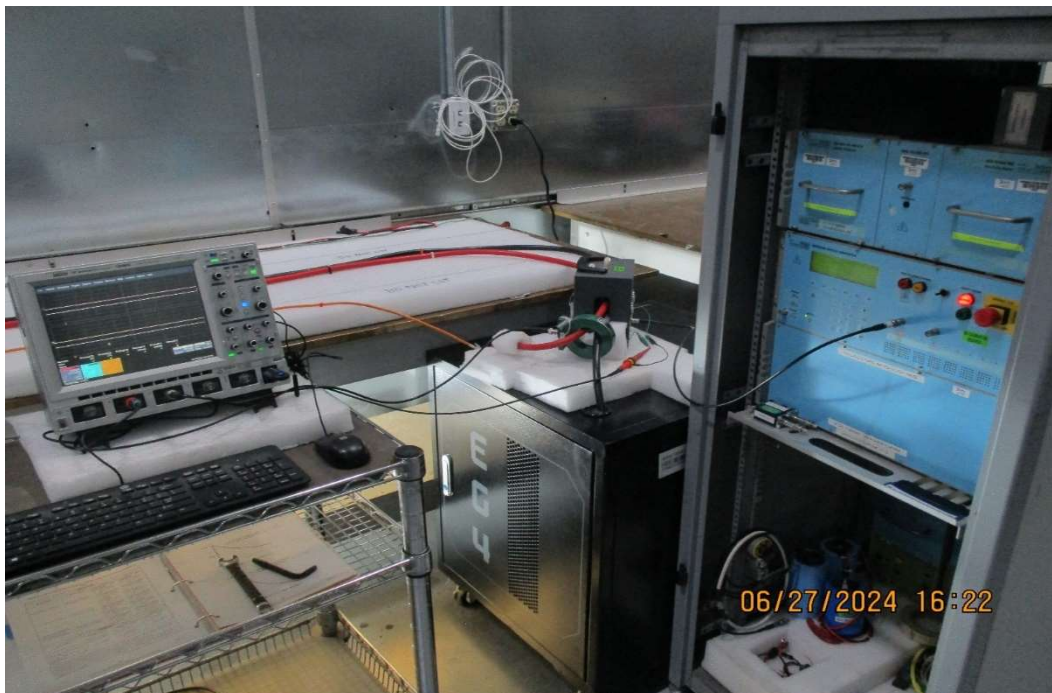

Test Setup for CS117, Actual Test Waveform #2 & #3 on Battery Bundle

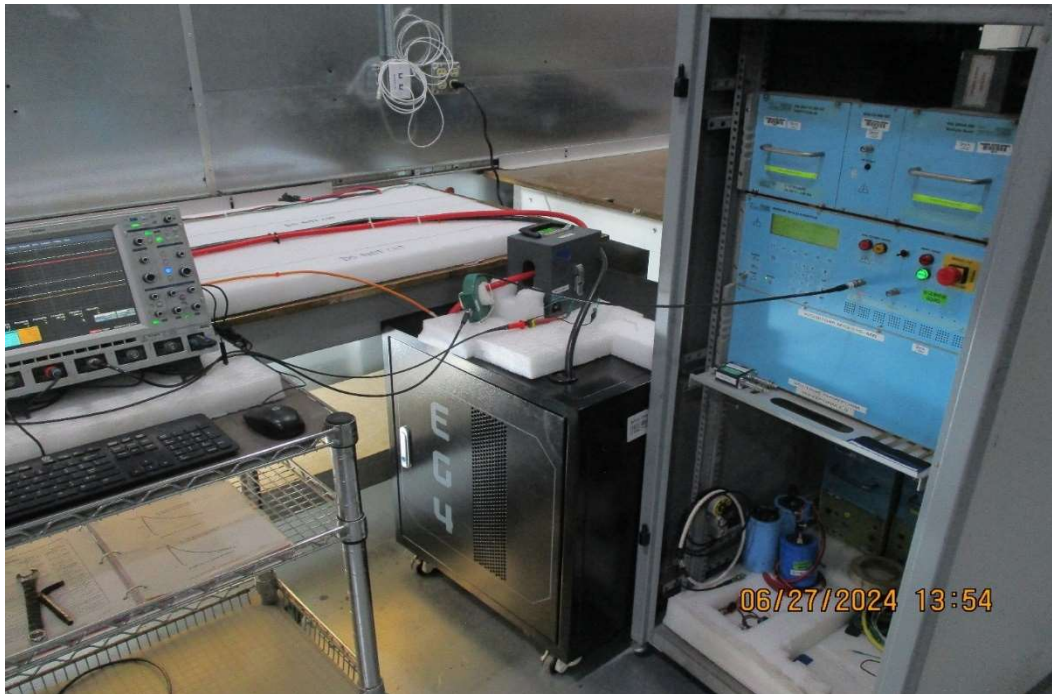

Test Setup for CS117, Actual Test Waveform #2 & #3 on Battery High Side



Test Setup for CS117, Actual Test Waveform #2 & #3 on Battery Return Side

Actual Test Photographs for Battery Wall Mount



Test Setup for CS117, General Waveform #1 Test Setup for Battery Wall Mount

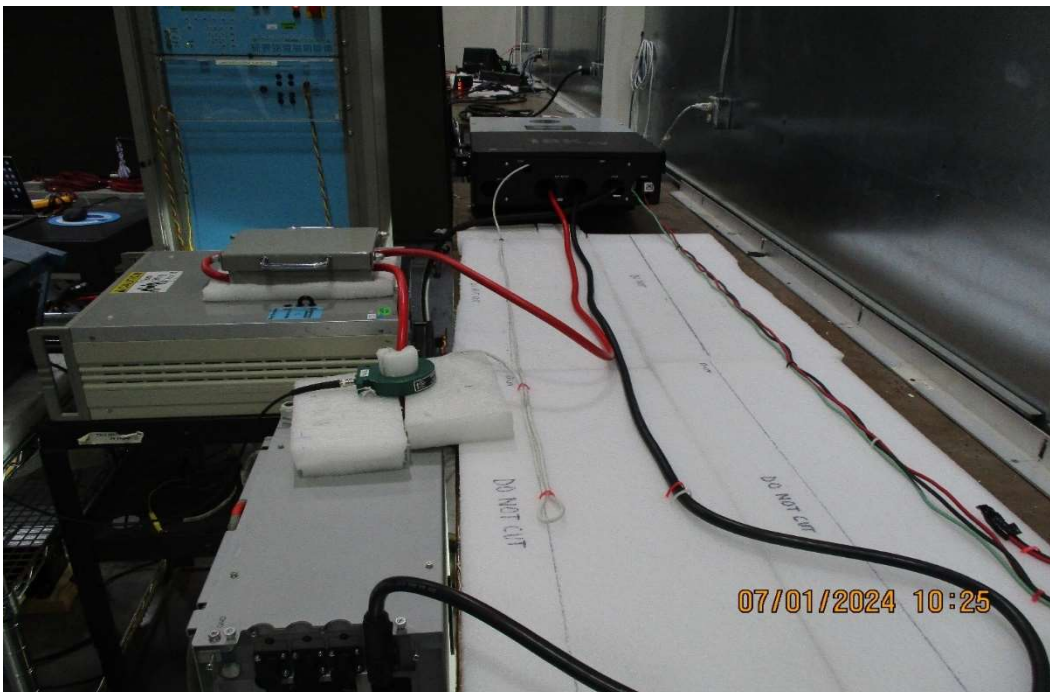

Test Setup for CS117, Actual Test Waveform #1 on Battery High Side

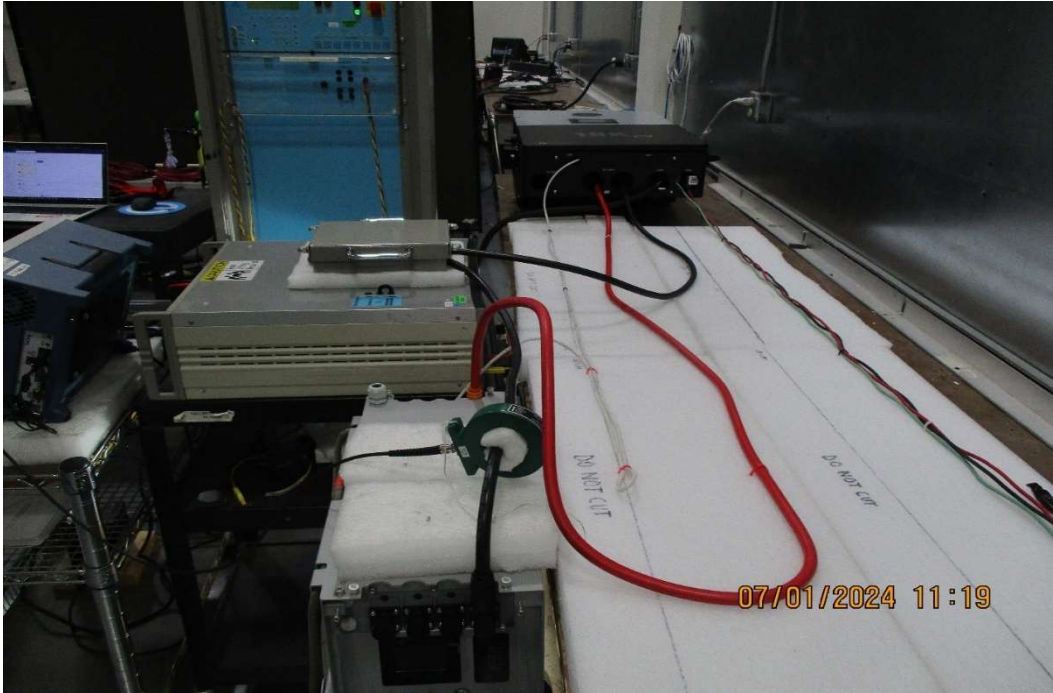

Test Setup for CS117, Actual Test Waveform #1 on Battery Return Side



Test Setup for CS117, Actual Test Waveform #2 on Battery Bundle



Test Setup for CS117, General Waveform #2 & #3 Test Setup for Battery Wall Mount



Test Setup for CS117, Actual Test Waveform #2 & #3 on Battery Bundle



Test Setup for CS117, Actual Test Waveform #2 & #3 on Battery High Side



Test Setup for CS117, Actual Test Waveform #2 & #3 on Battery Return Side

5.3.8 CS117 Verification Test Data

CS117 Current Verification Multiple Stroke Waveform #1 at 60A

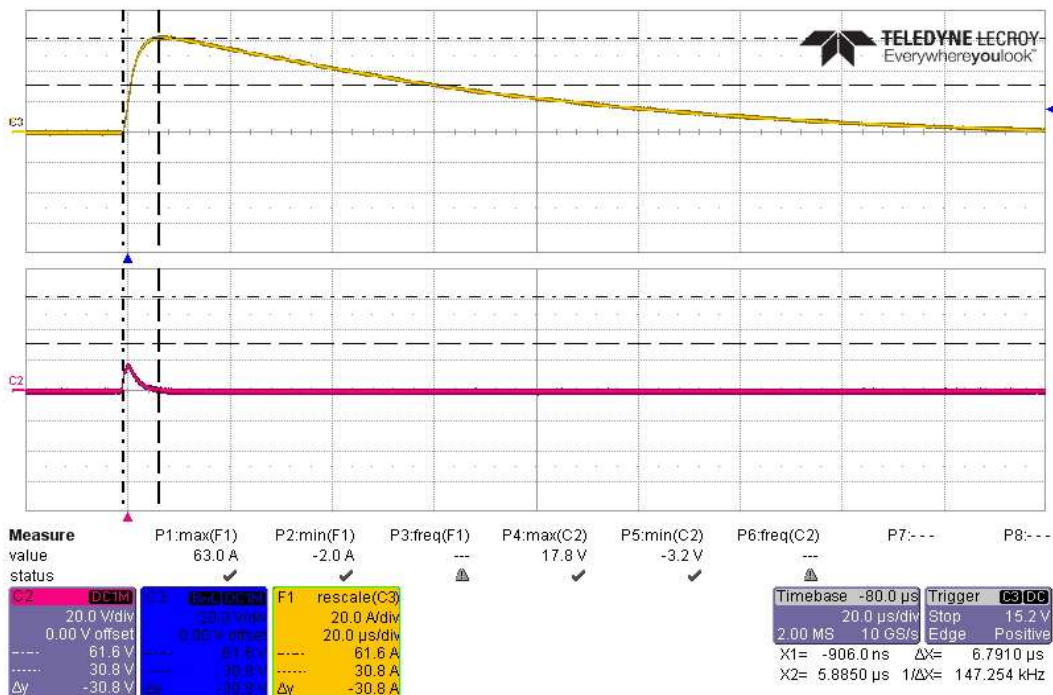

CS117 Current Verification Waveform #1, First Transient +60A, T1

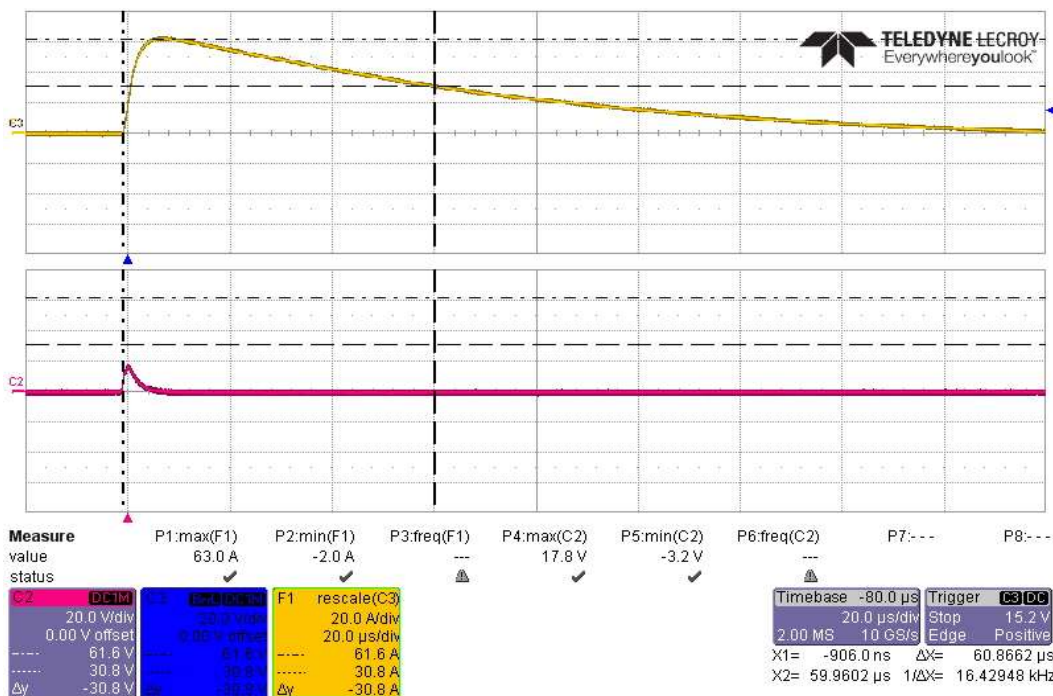

CS117 Current Verification Waveform #1, First Transient +60A, T2

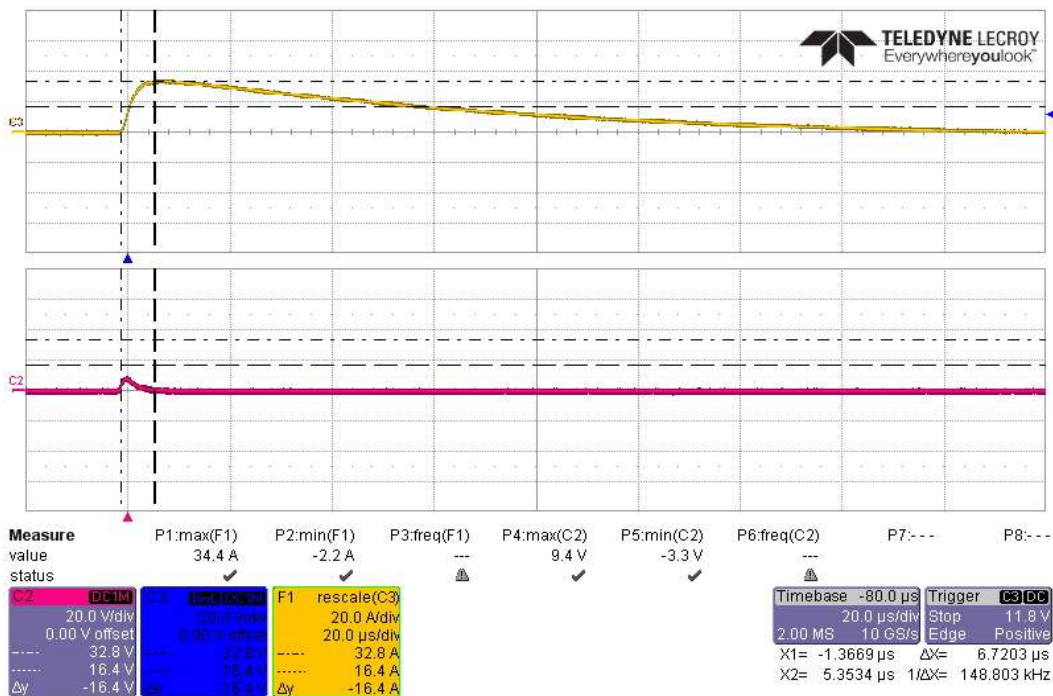

CS117 Current Verification Waveform #1, Subsequent Transient +30A, T1

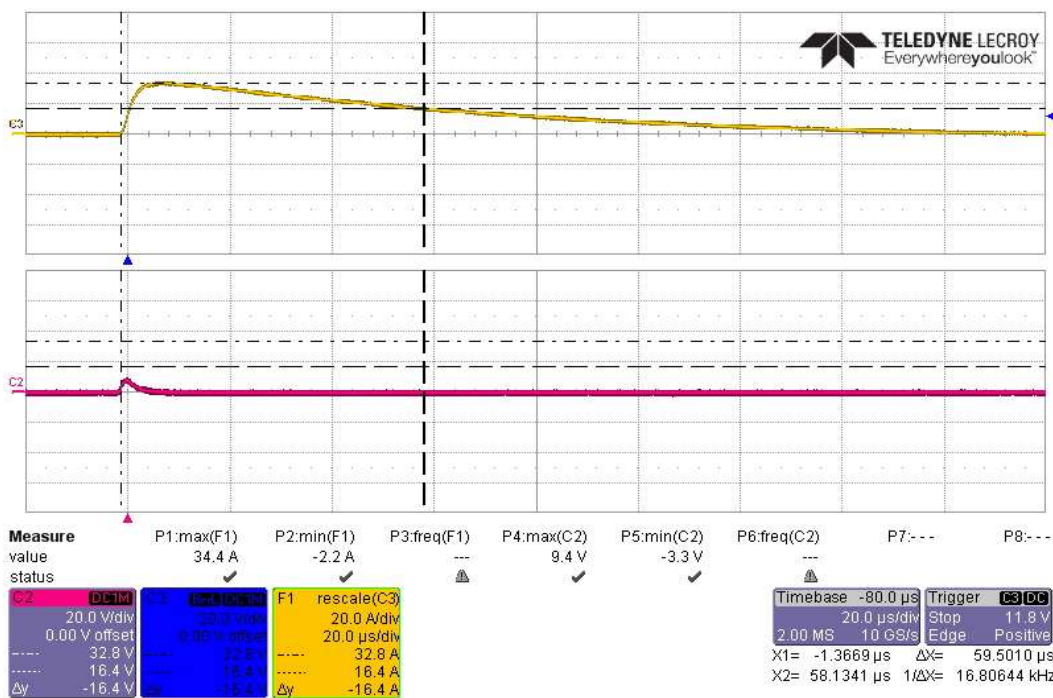

CS117 Current Verification Waveform #1, Subsequent Transient +30A, T2

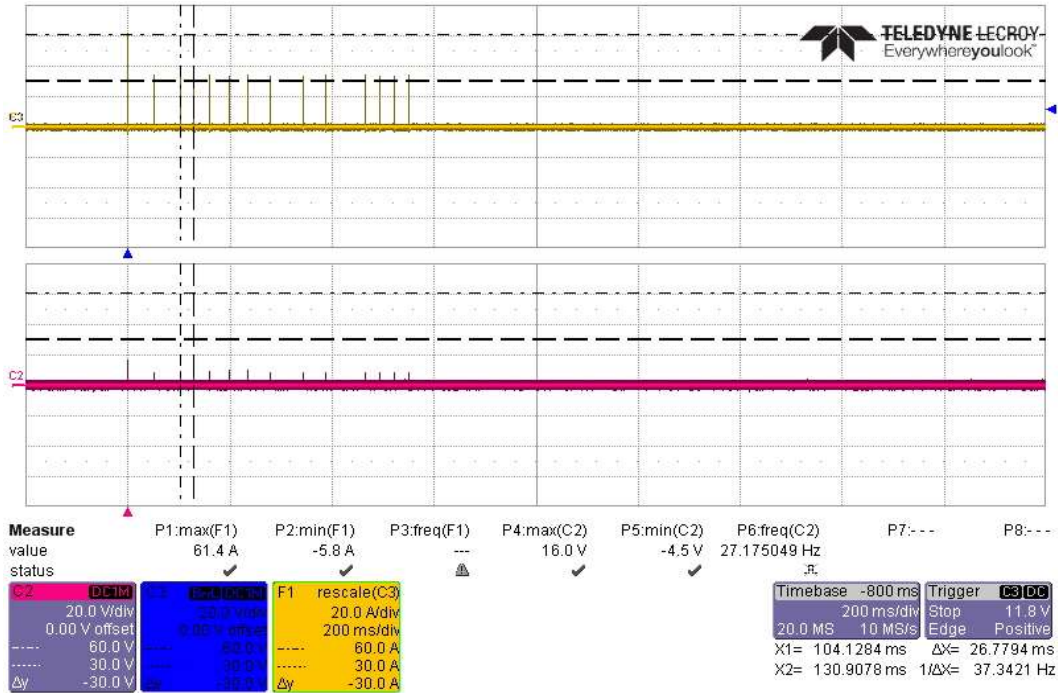

CS117 Current Verification Waveform #1, 14 Transients +60A/30A

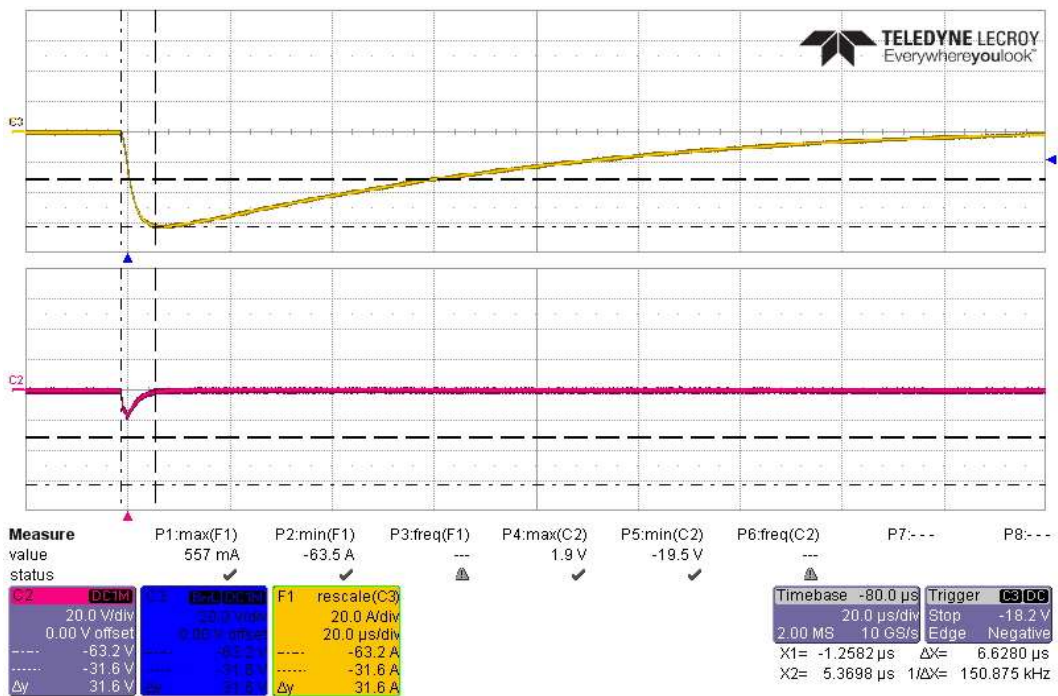

CS117 Current Verification Waveform #1, First Transient -60A, T1

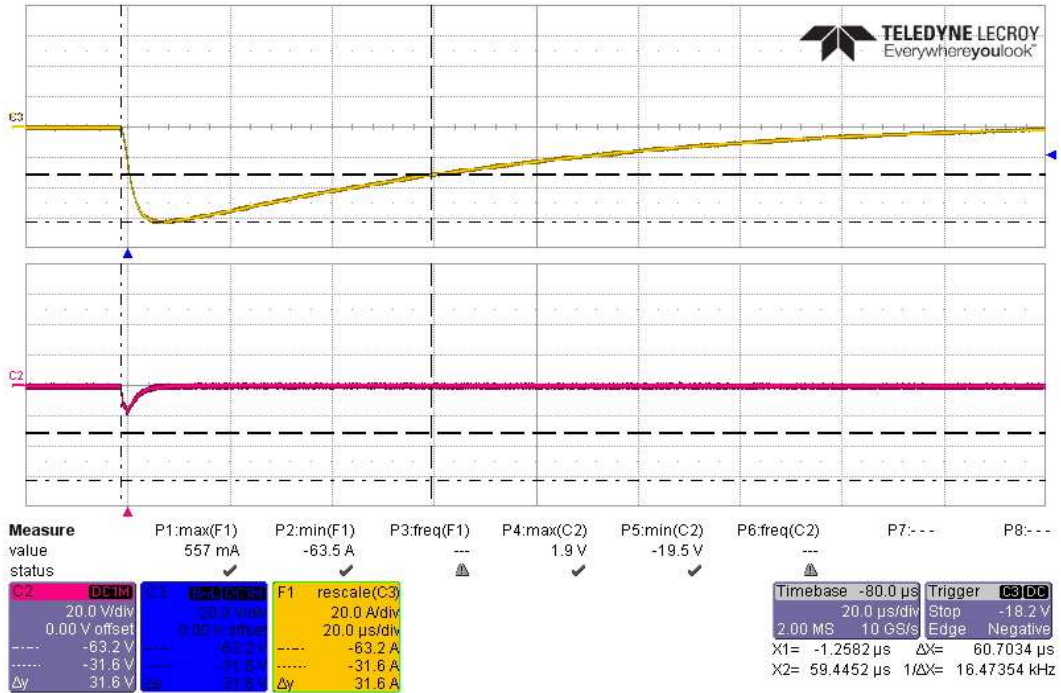

CS117 Current Verification Waveform #1, First Transient -60A, T2

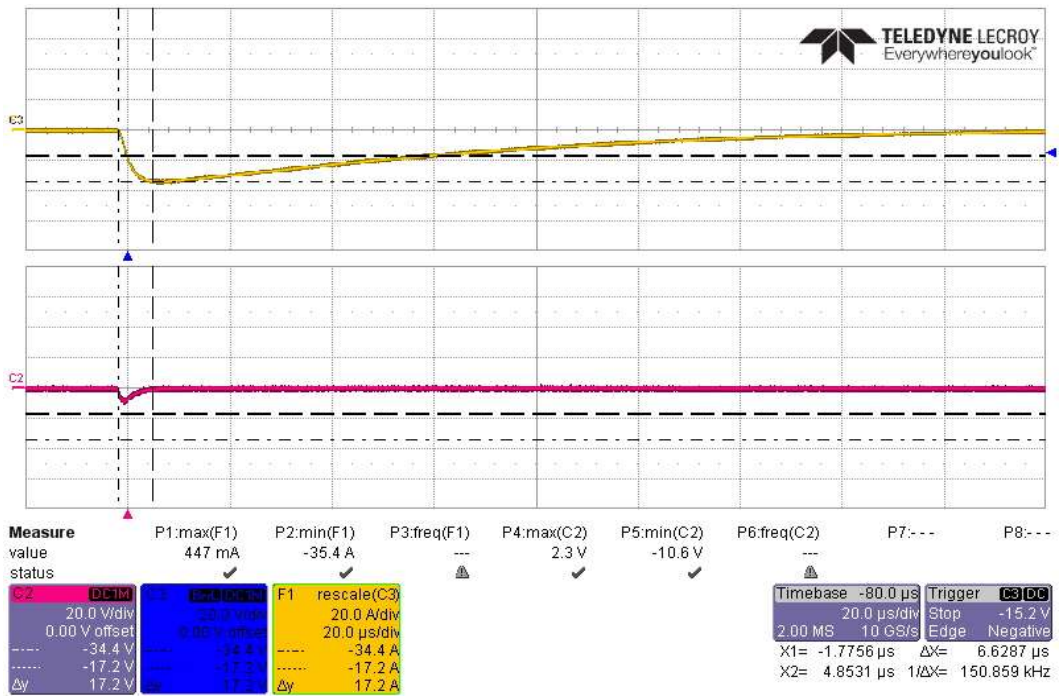

CS117 Current Verification Waveform #1, Subsequent Transient -30A, T1

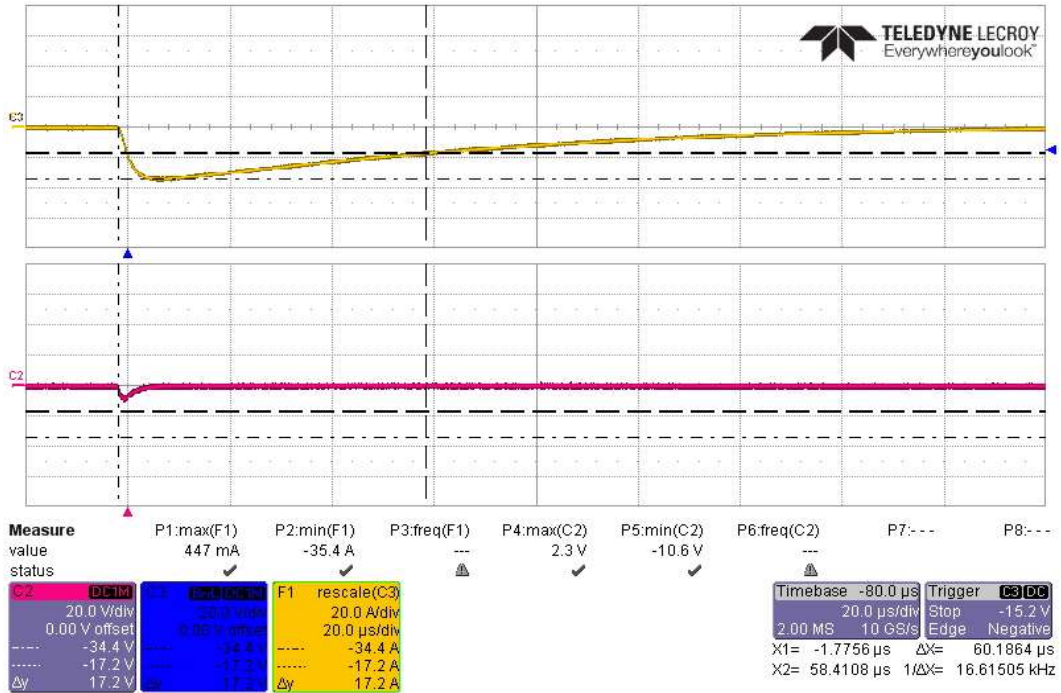

CS117 Current Verification Waveform #1, Subsequent Transient -30A, T2

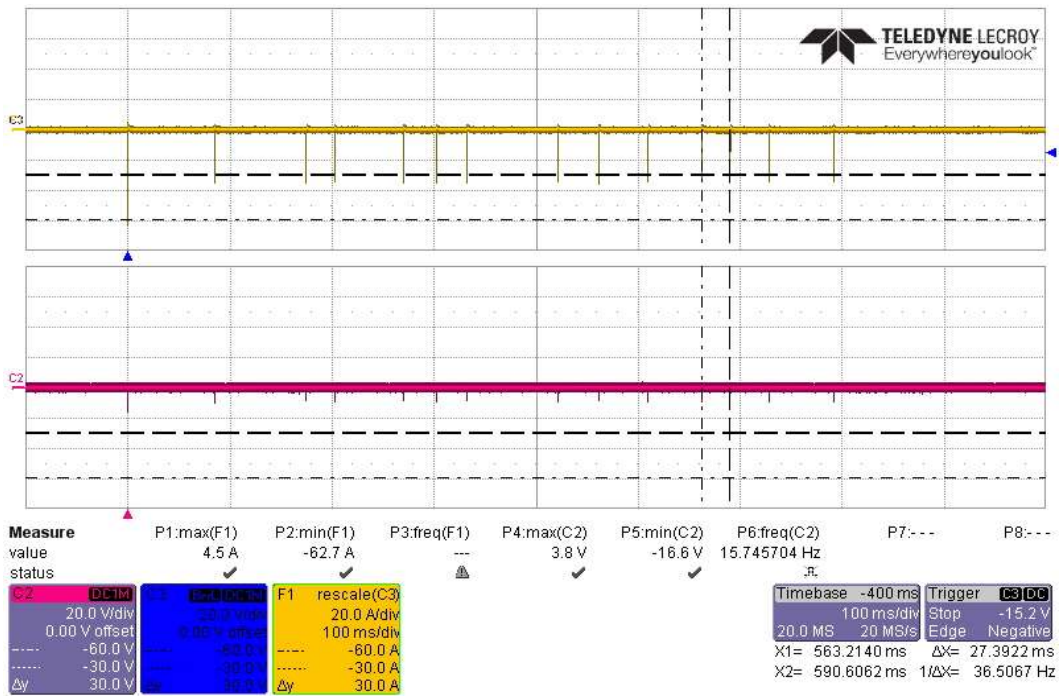

CS117 Current Verification Waveform #1, 14 Transients -60A/30A

CS117 Current Verification Multiple Stroke Waveform #1 at 120A

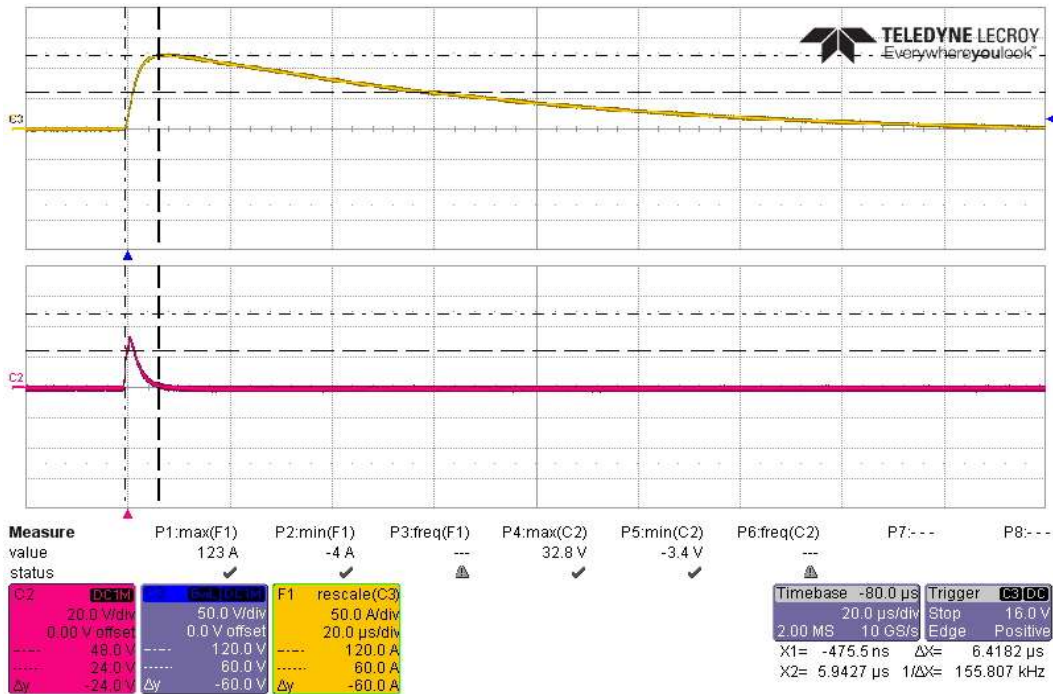

CS117 Current Verification Waveform #1, First Transient +120A, T1

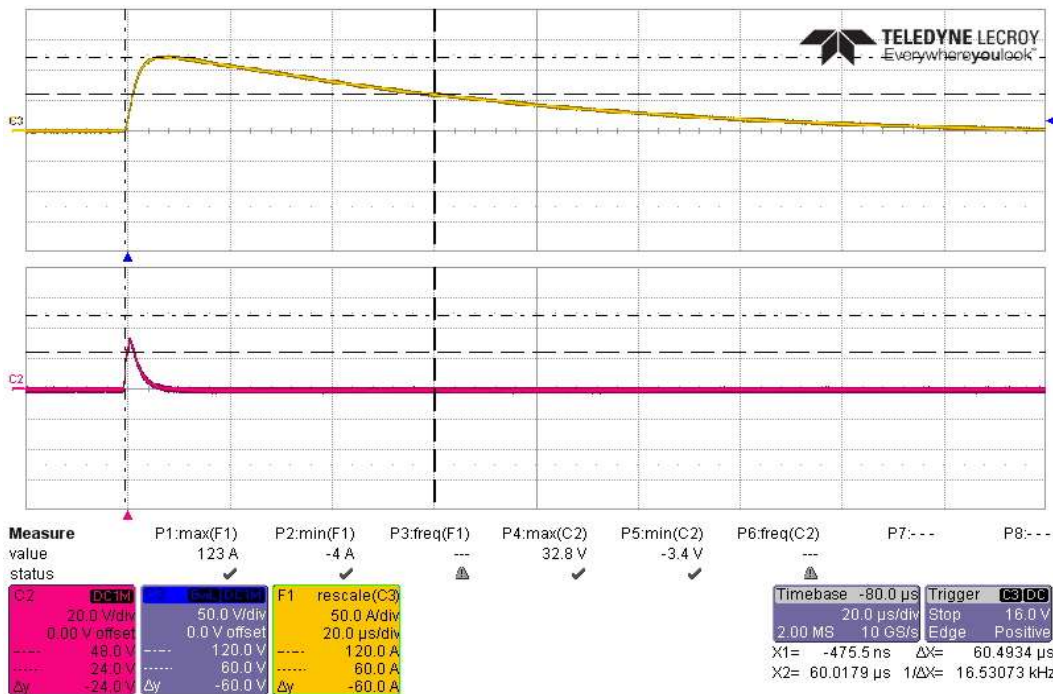

CS117 Current Verification Waveform #1, First Transient +120A, T2

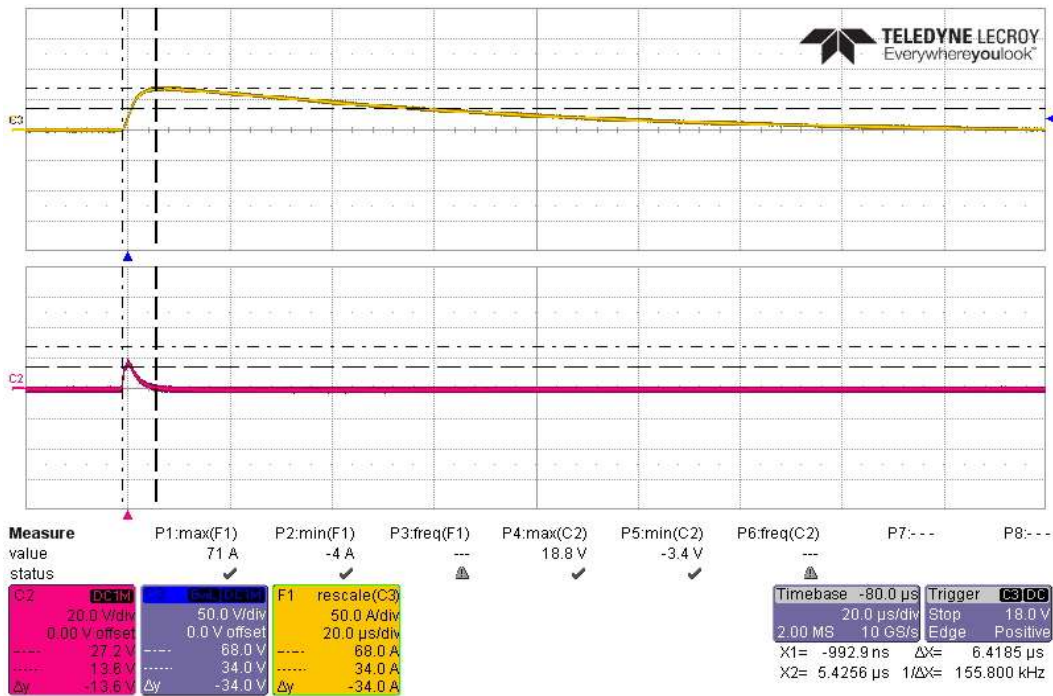

CS117 Current Verification Waveform #1, Subsequent Transient +60A, T1

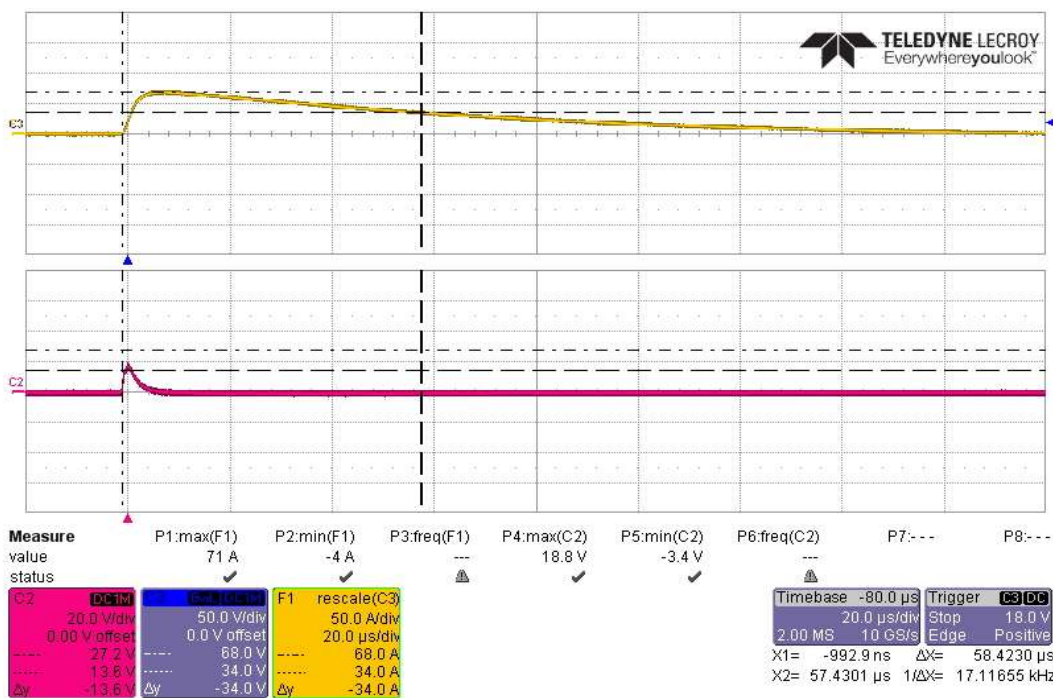

CS117 Current Verification Waveform #1, Subsequent Transient +60A, T2

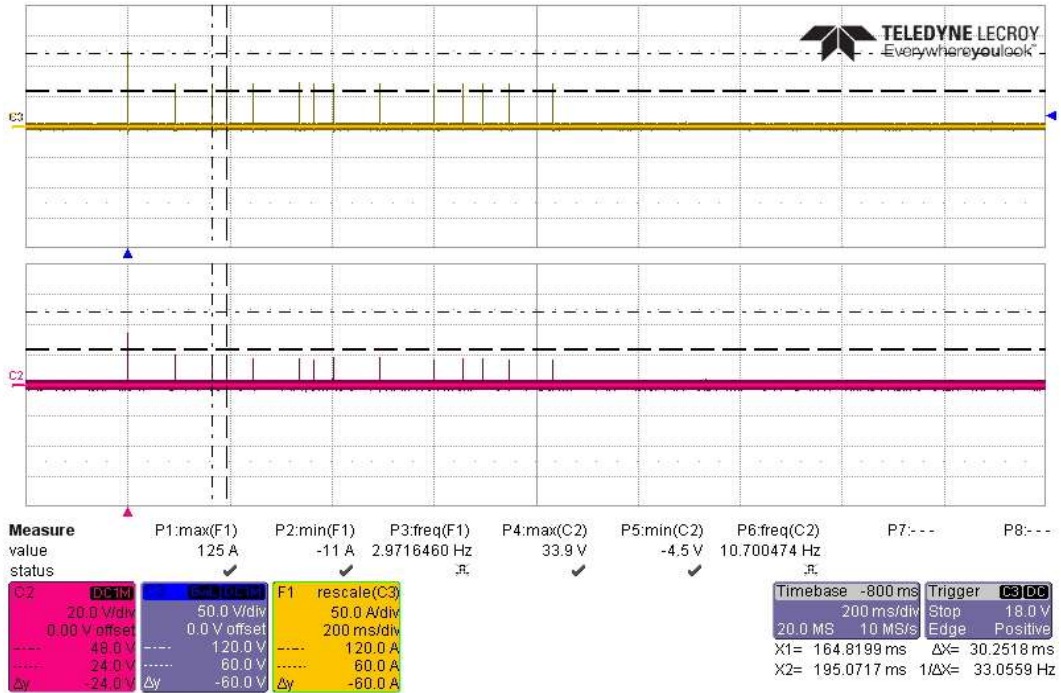

CS117 Current Verification Waveform #1, 14 Transients +120A/60A

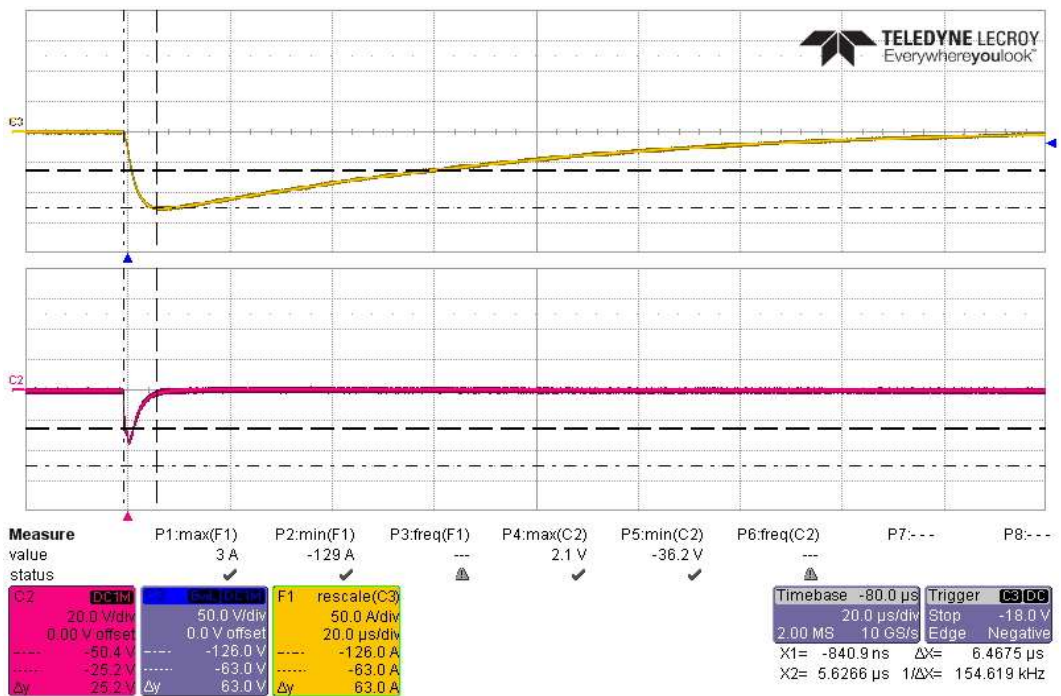

CS117 Current Verification Waveform #1, First Transient -120A, T1

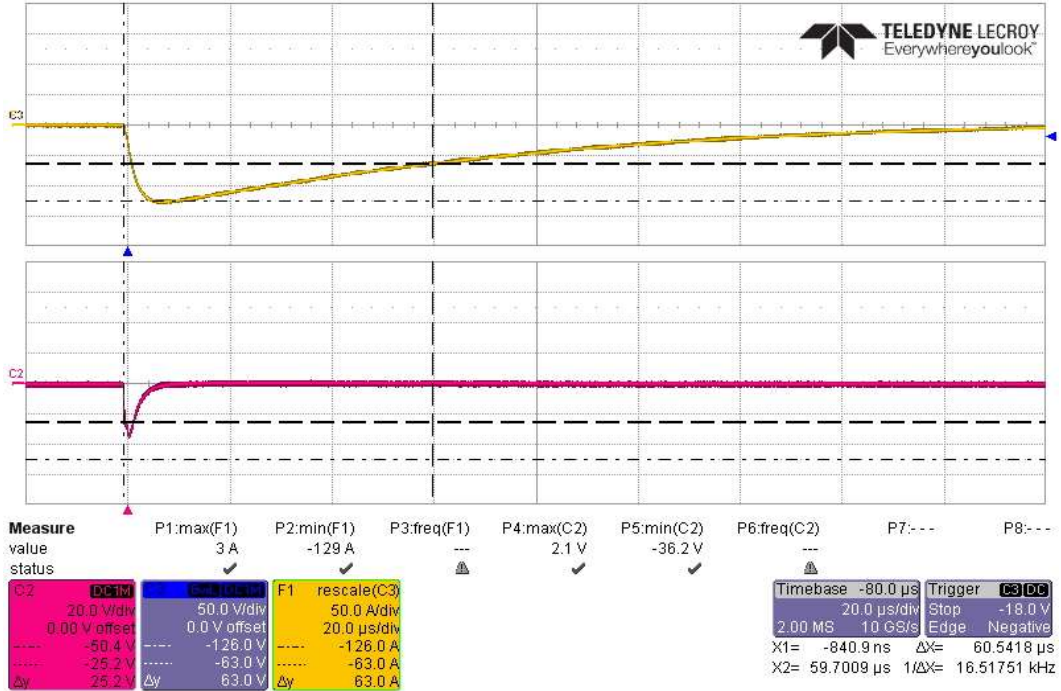

CS117 Current Verification Waveform #1, First Transient -120A, T2

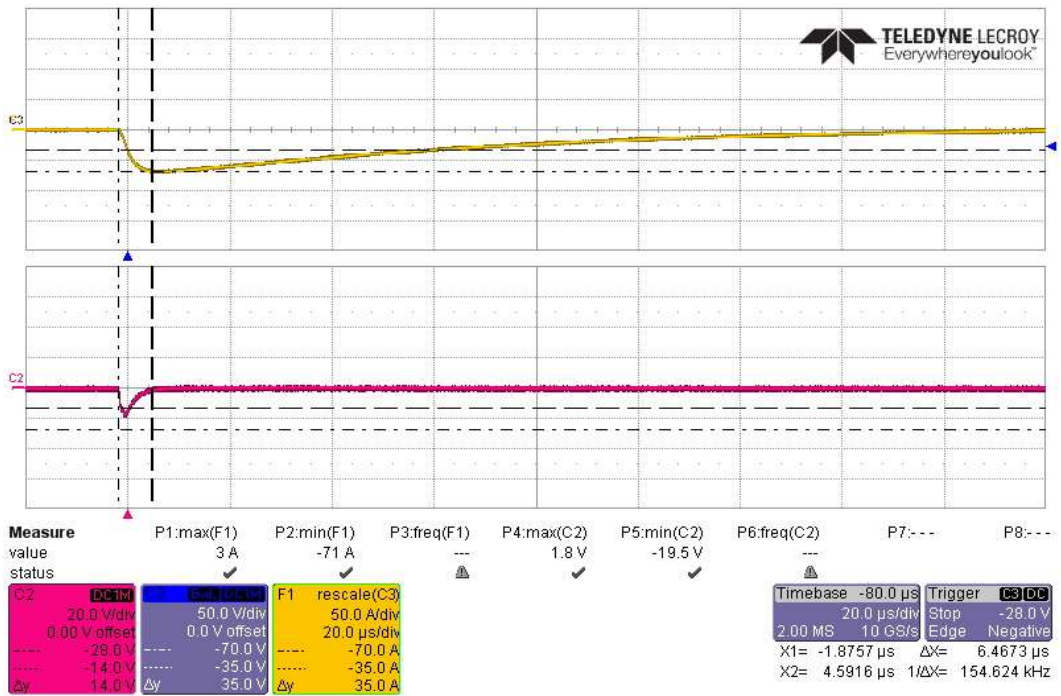

CS117 Current Verification Waveform #1, Subsequent Transient -60A, T1

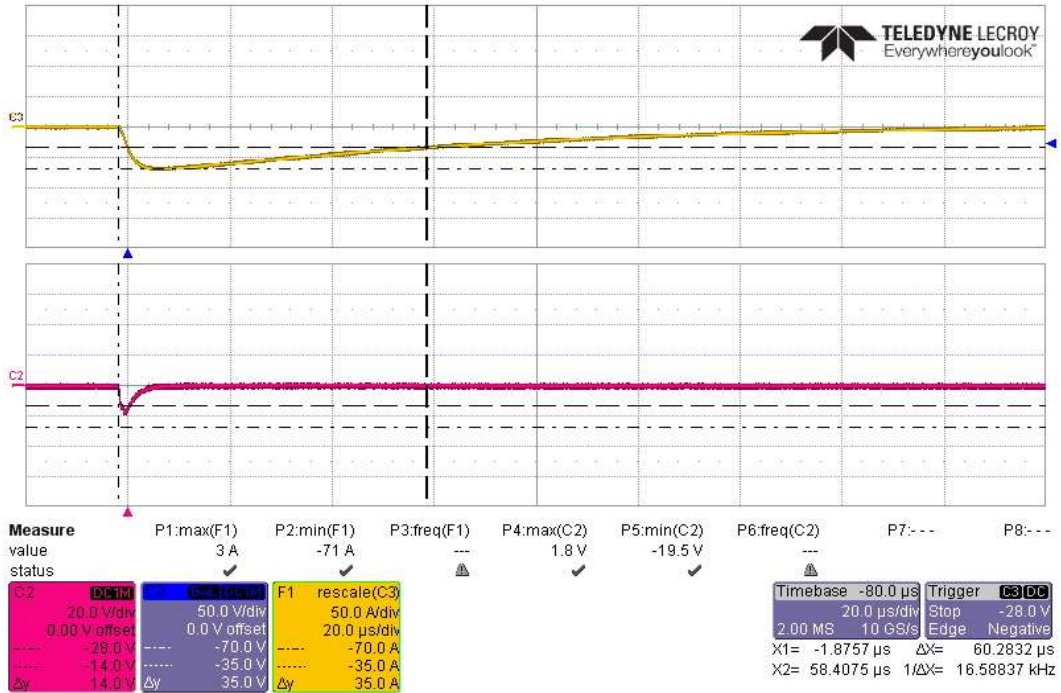

CS117 Current Verification Waveform #1, Subsequent Transient -60A, T2

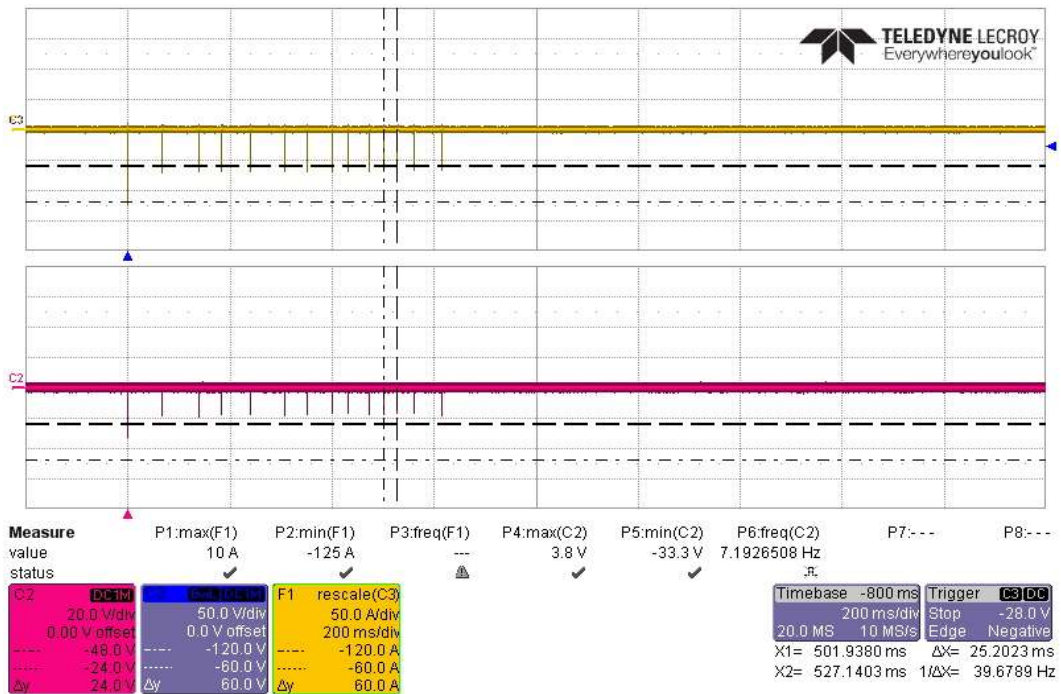

CS117 Current Verification Waveform #1, 14 Transients -120A/60A

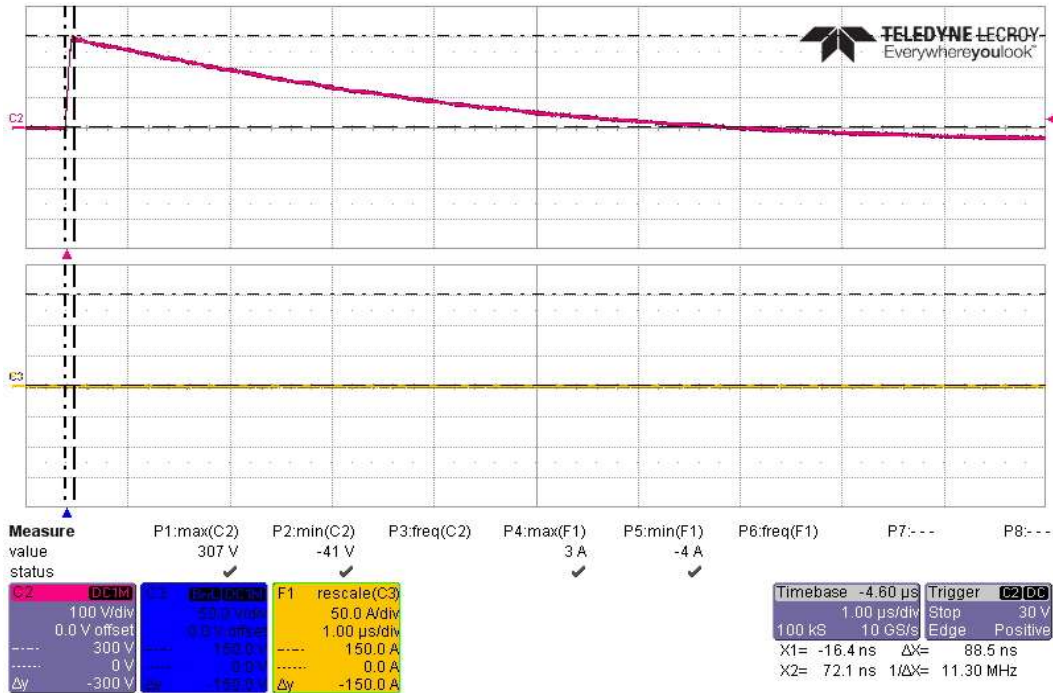
CS117 Voltage Verification Multiple Stroke Waveform #2 at 300V

CS117 Voltage Verification Waveform #2, First Transient +300V, T1

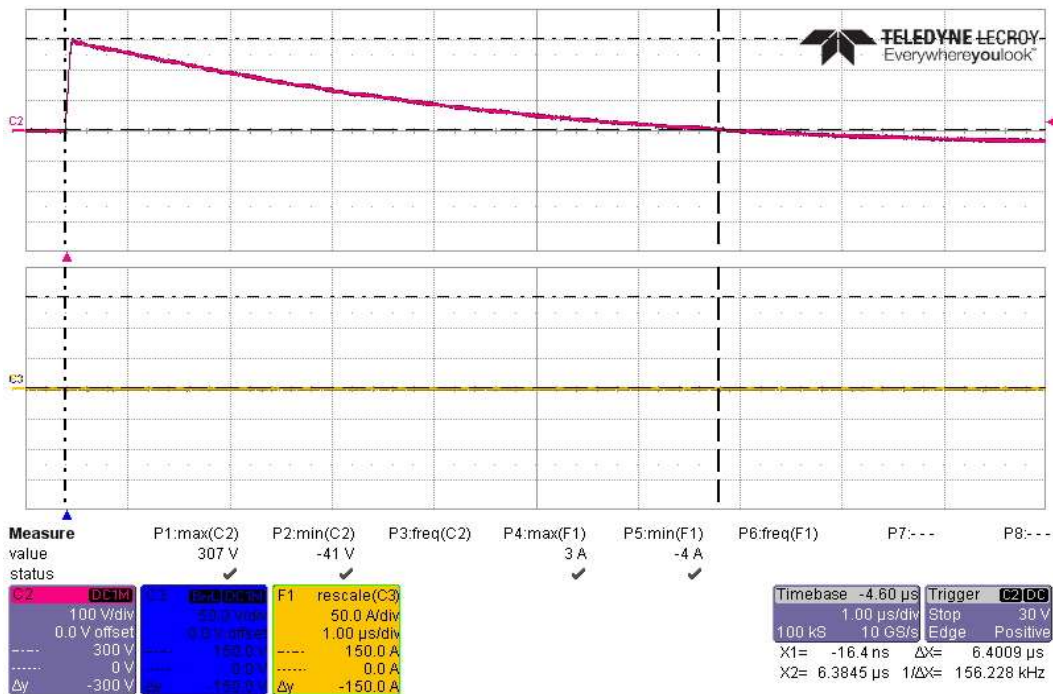

CS117 Voltage Verification Waveform #2, First Transient +300V, T2

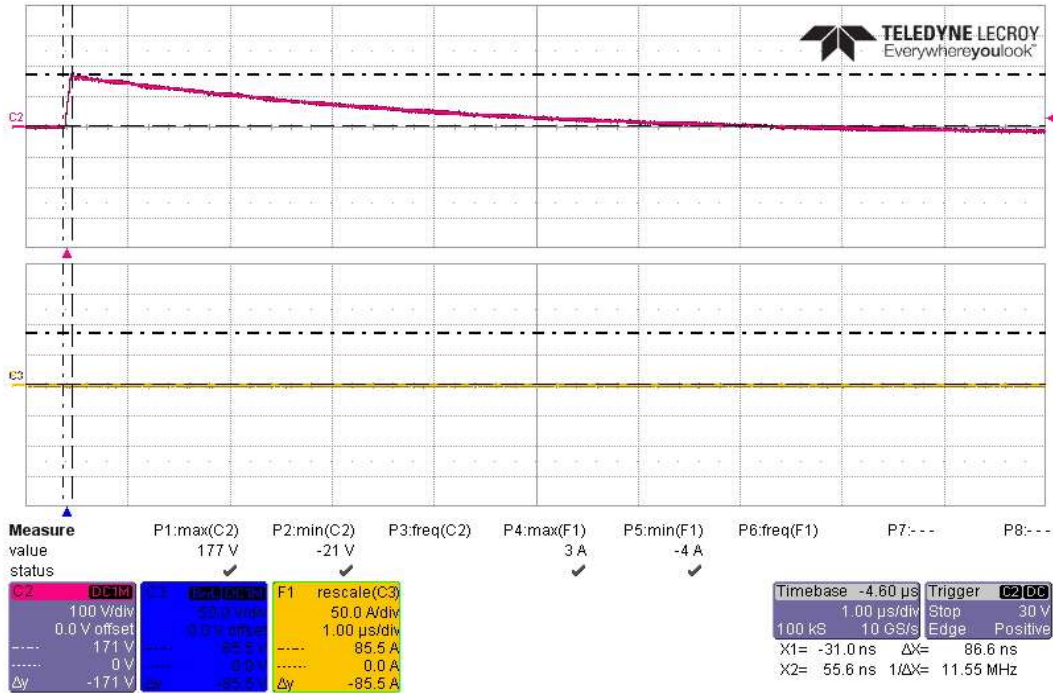

CS117 Voltage Verification Waveform #2, Subsequent Transient +150V, T1

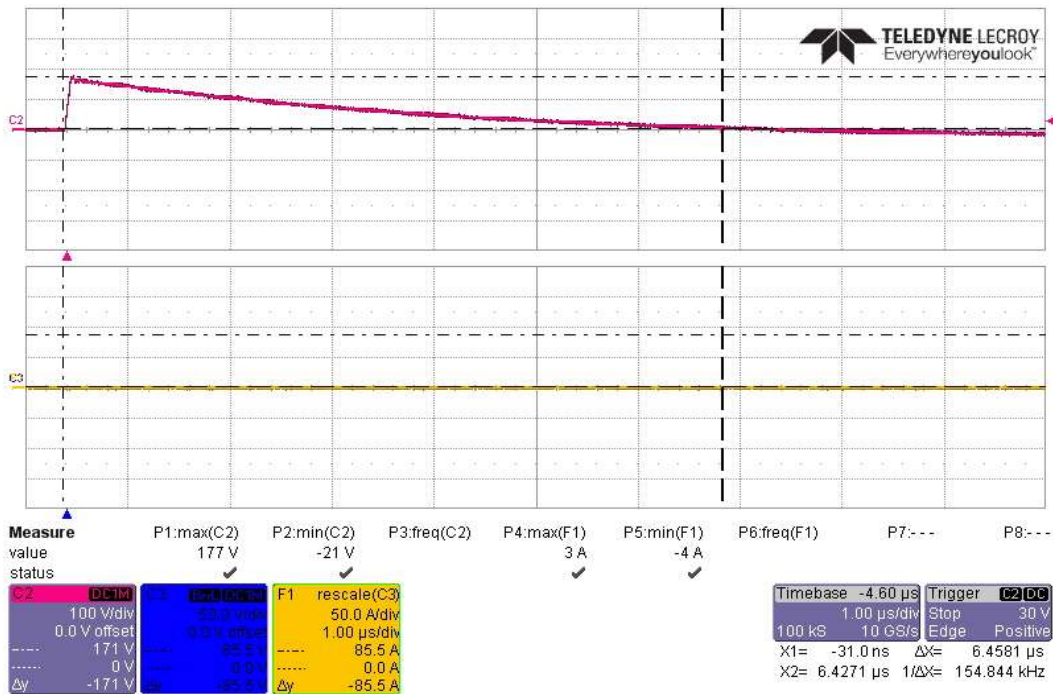

CS117 Voltage Verification Waveform #2, Subsequent Transient +150V, T2

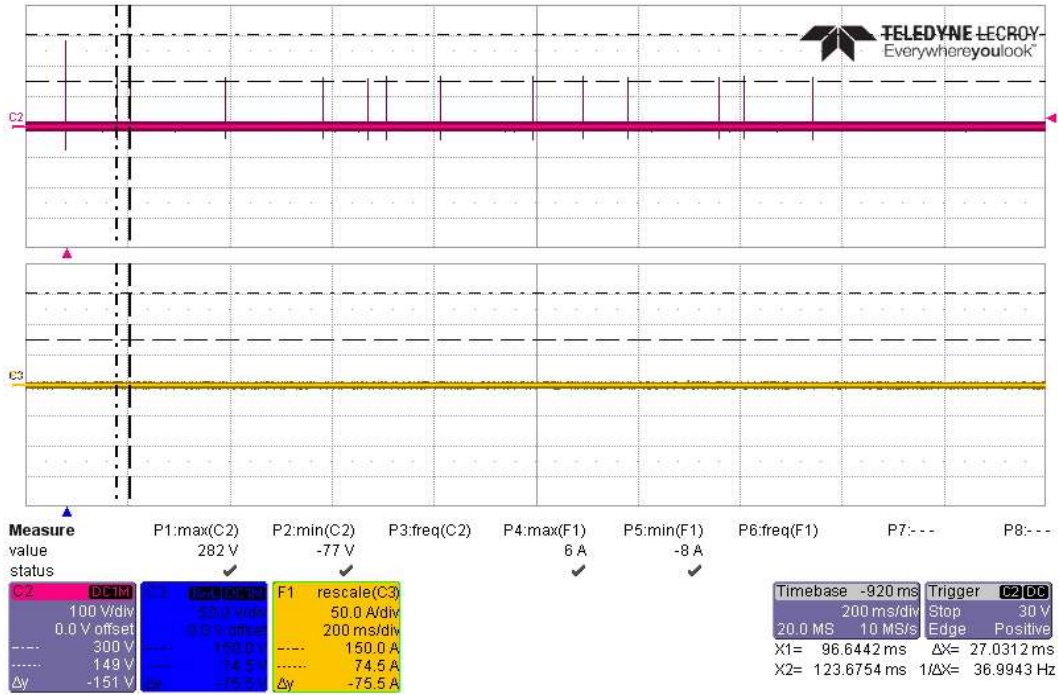

CS117 Voltage Verification Waveform #2, 14 Transients +300V/150VA

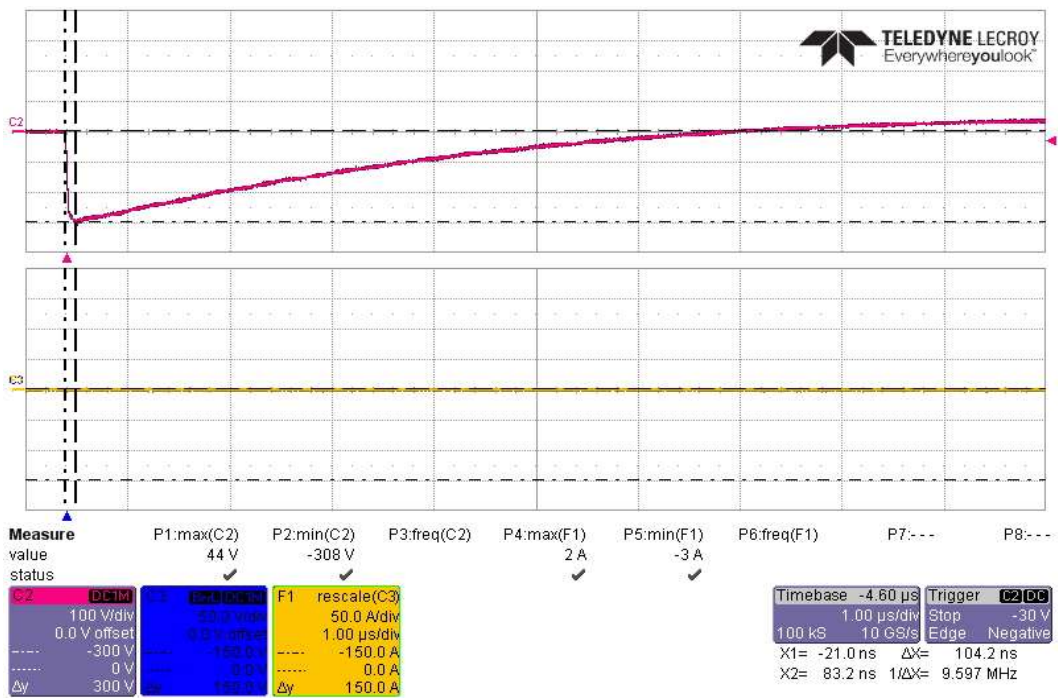

CS117 Voltage Verification Waveform #2, First Transient -300V, T1

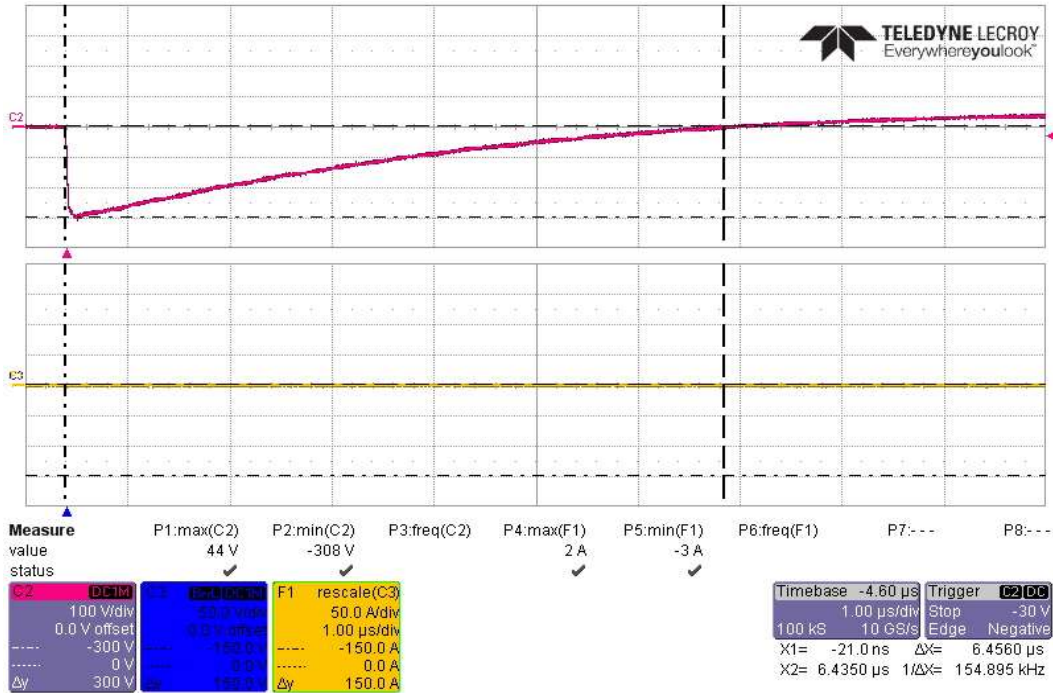

CS117 Voltage Verification Waveform #2, First Transient -300V, T2

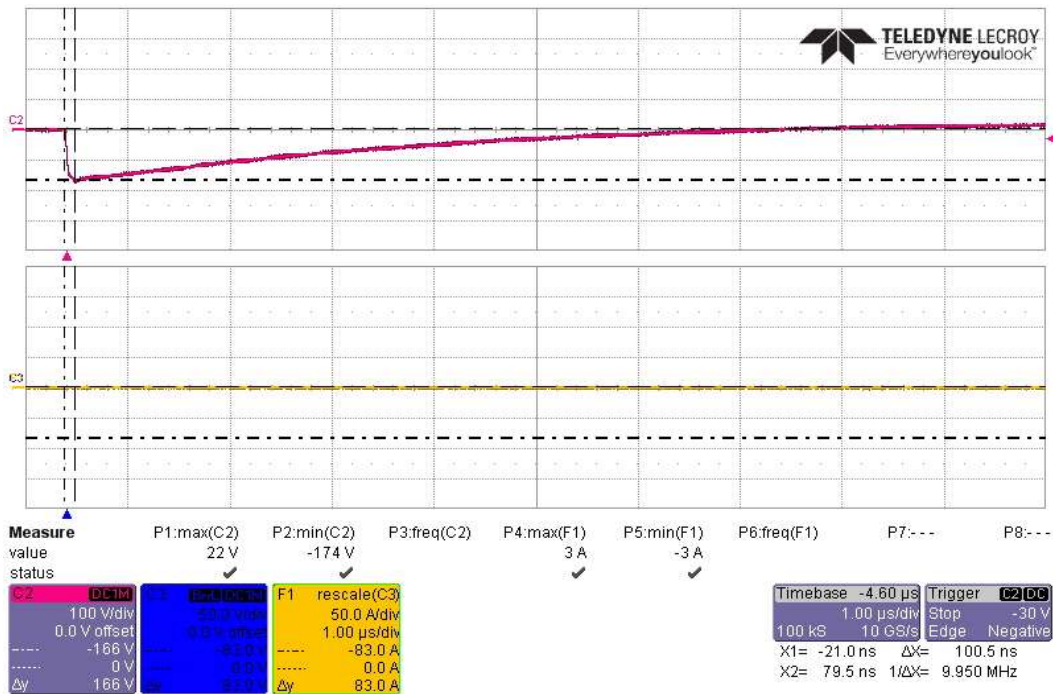

CS117 Voltage Verification Waveform #2, Subsequent Transient -150V, T1

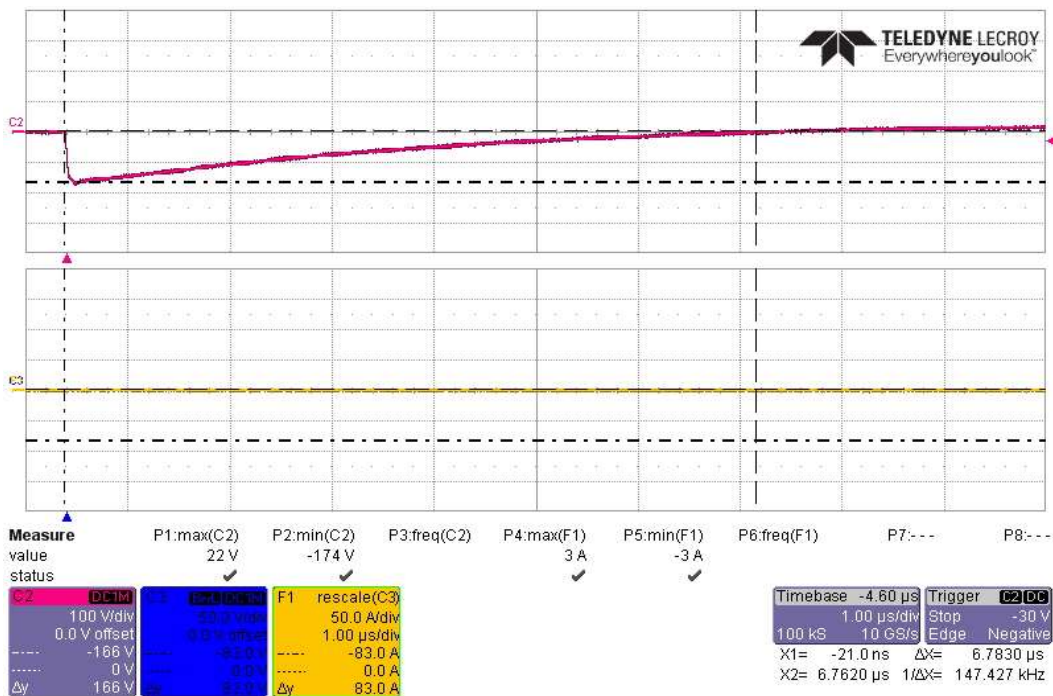

CS117 Voltage Verification Waveform #2, Subsequent Transient -150V, T2

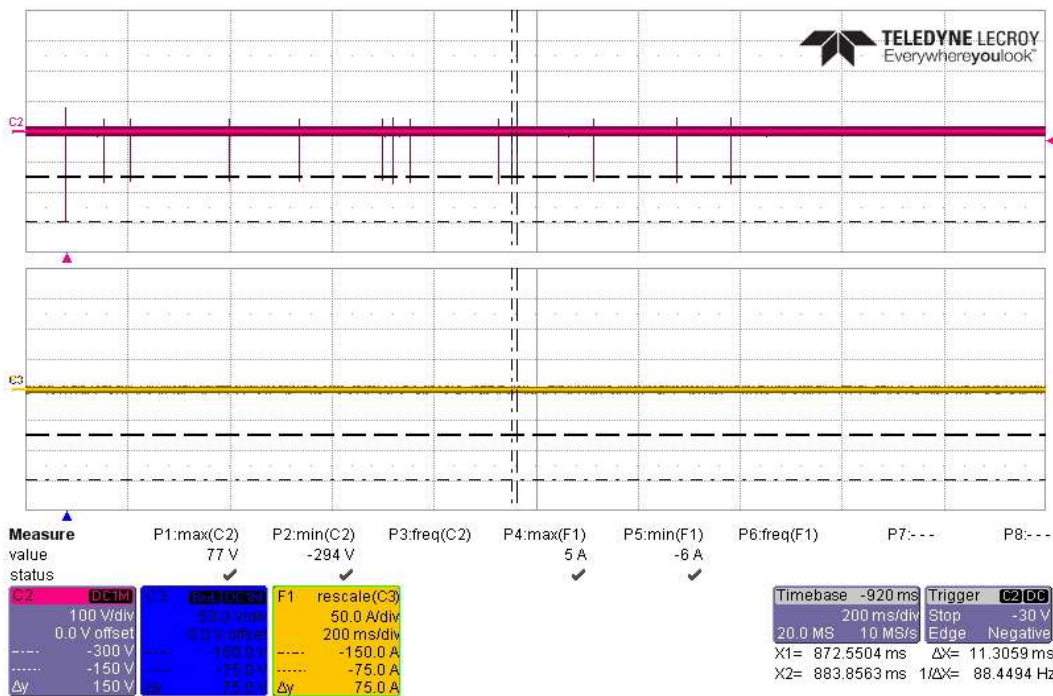

CS117 Voltage Verification Waveform #2, 14 Transients -300V/150VA

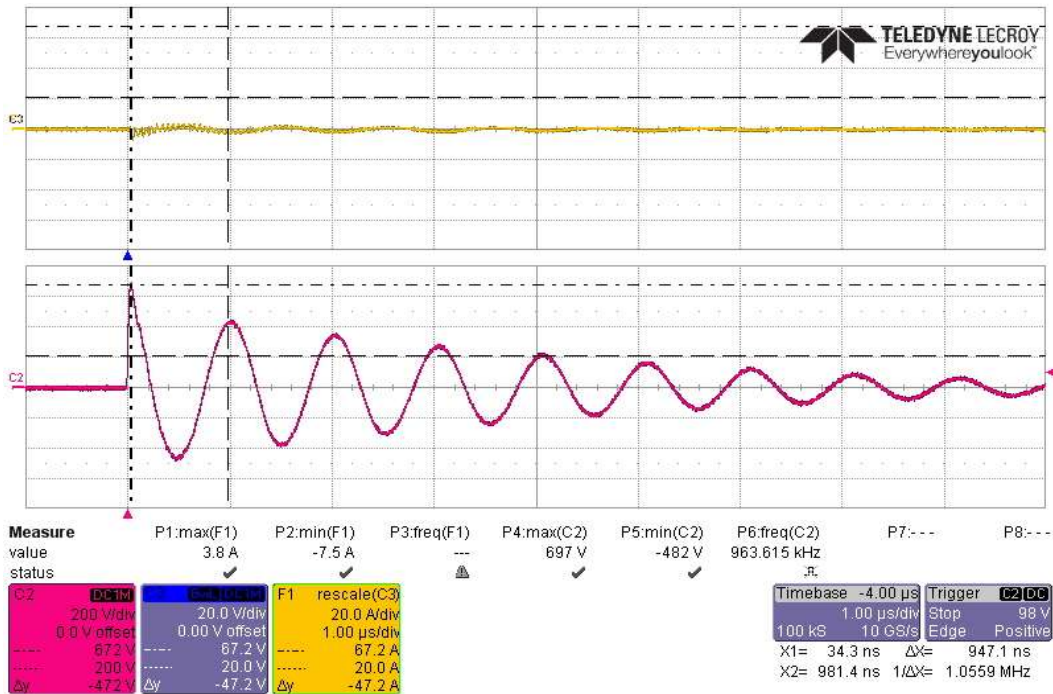
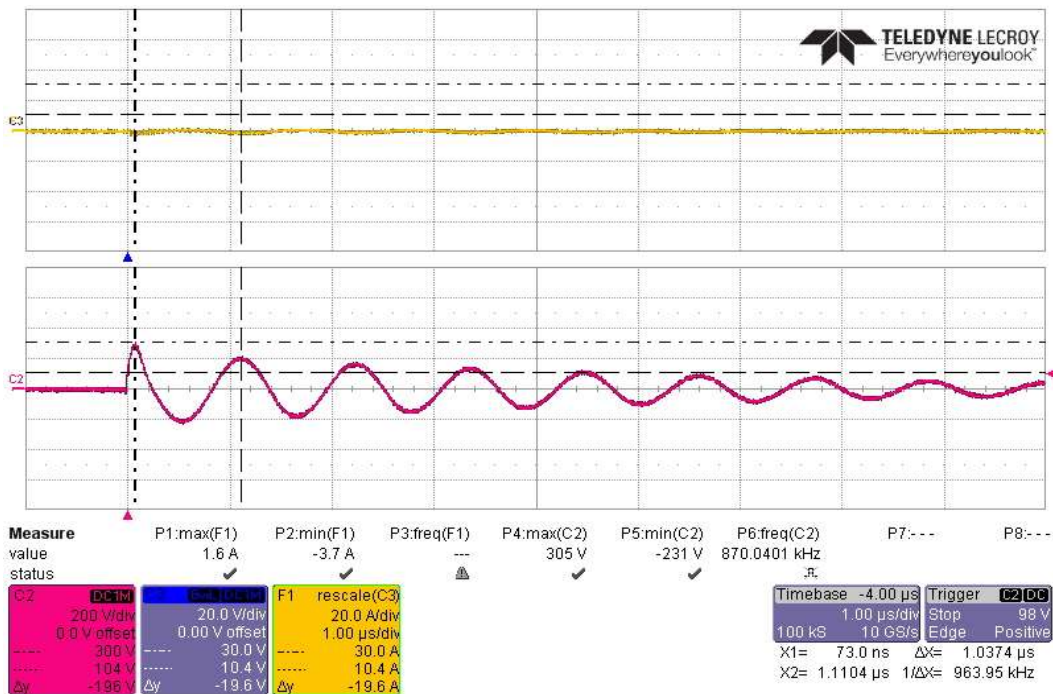
CS117 Voltage and Current Verification Multiple Stroke Waveform #3 at 1MHz with 600V/24A/48A

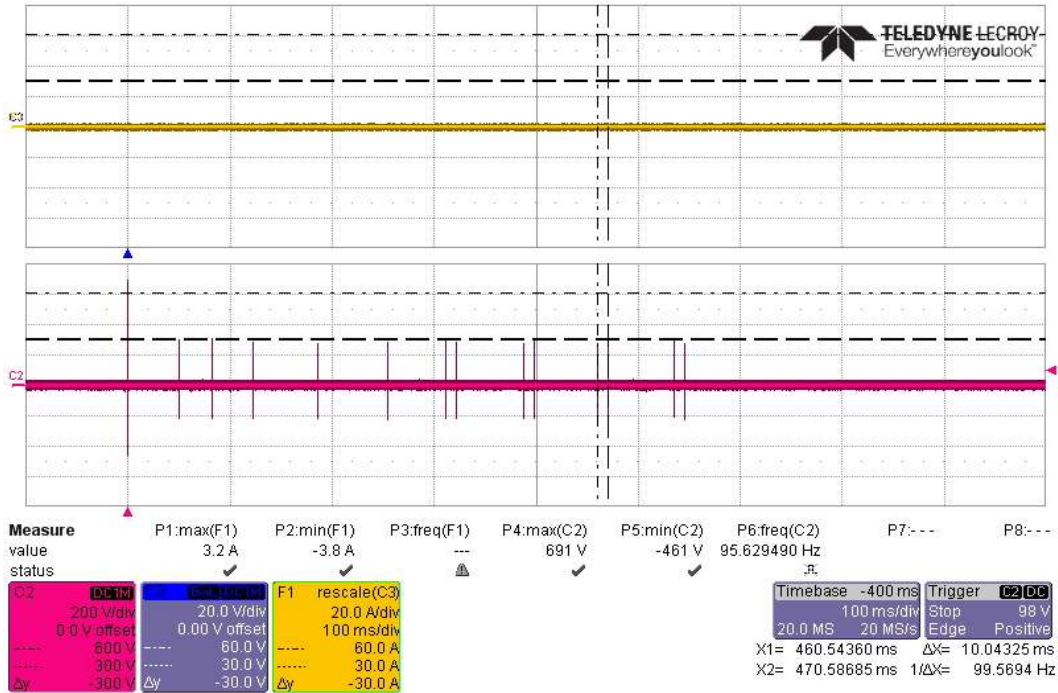
CS117 Voltage Verification Waveform #3 at 1MHz, First Transient +600V

CS117 Voltage Verification Waveform #3 at 1MHz, Subsequent Transient +300V

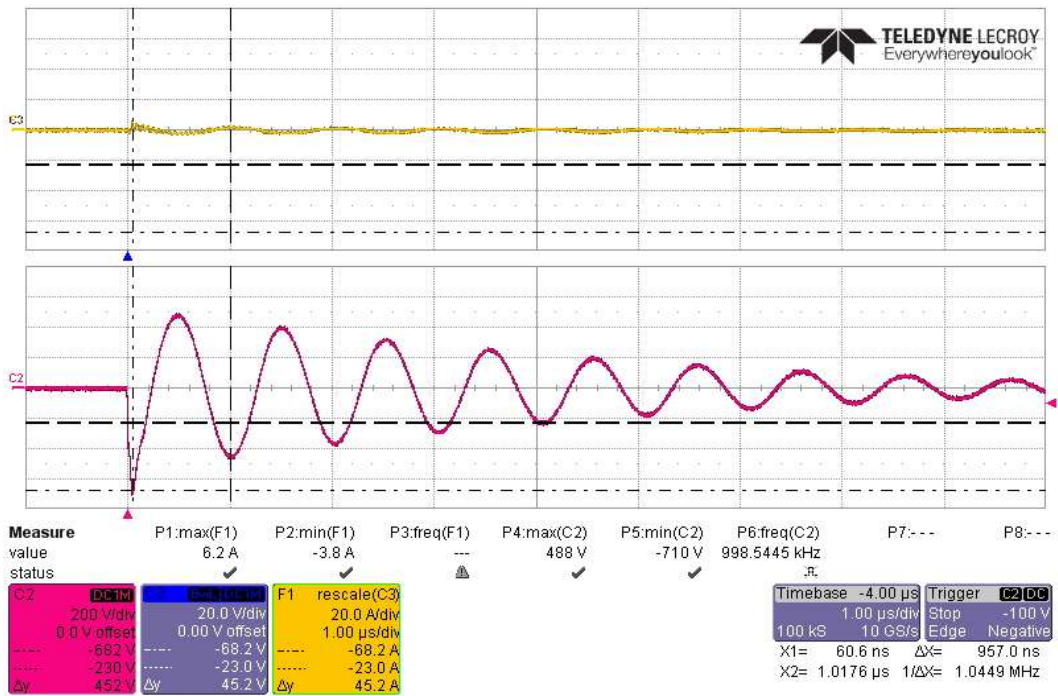

CS117 Voltage Verification Waveform #3 at 1MHz, 14 Transients +600V/300V

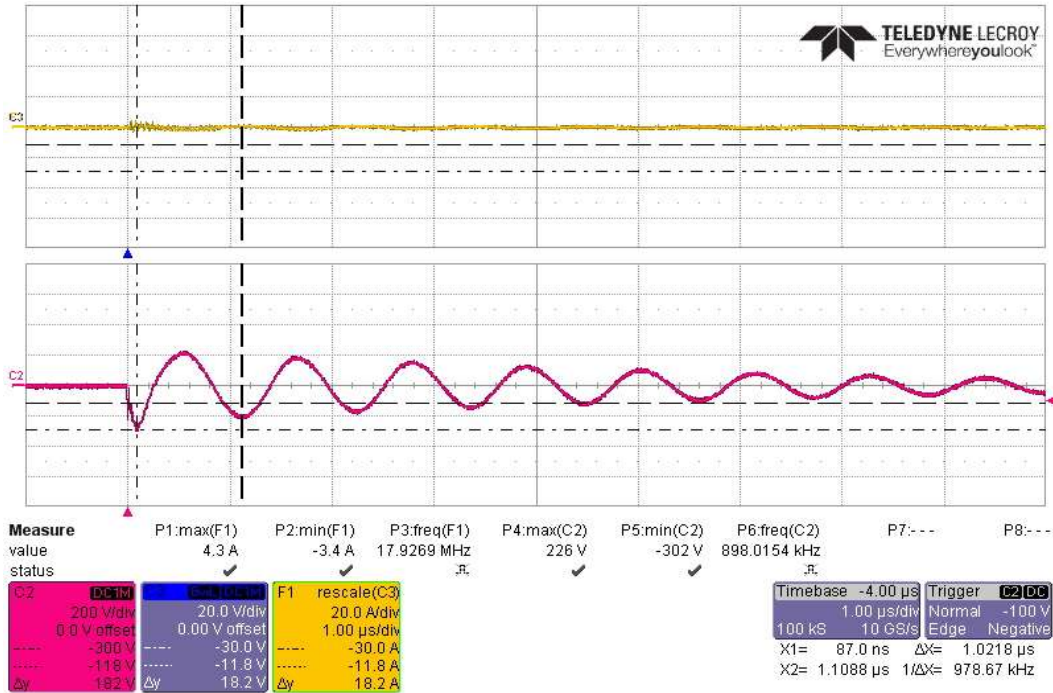

CS117 Voltage Verification Waveform #3 at 1MHz, First Transient -600V



CS117 Voltage Verification Waveform #3 at 1MHz, Subsequent Transient -300V

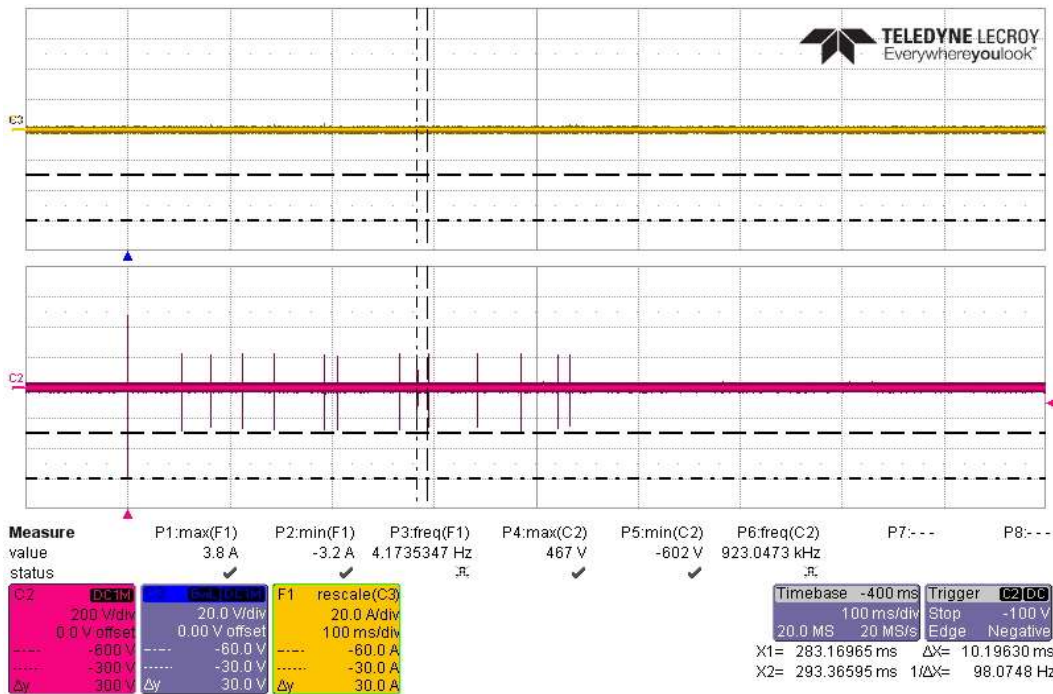

CS117 Voltage Verification Waveform #3 at 1MHz, 14 Transients -600V/300V

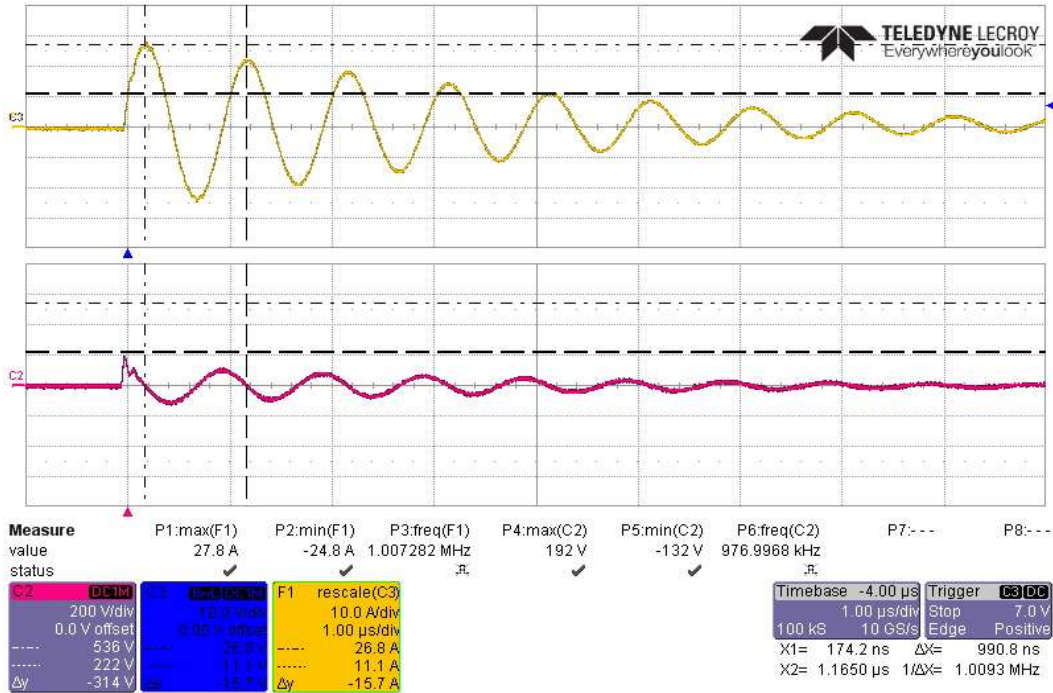

CS117 Current Verification Waveform #3 at 1MHz, First Transient +24A

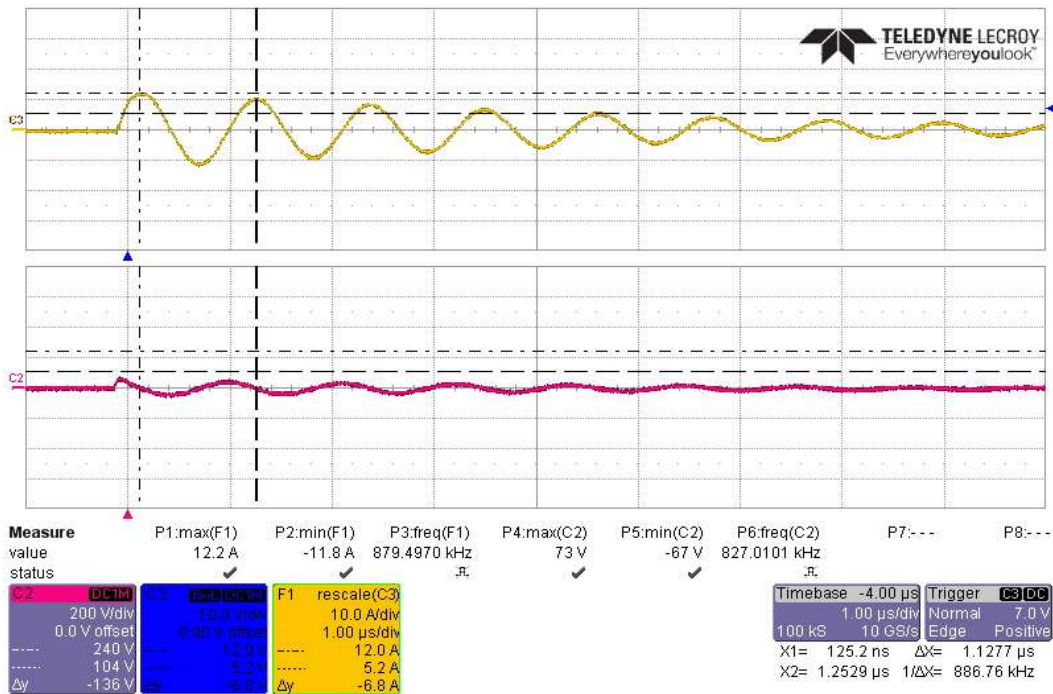

CS117 Current Verification Waveform #3 at 1MHz, Subsequent Transient +12A

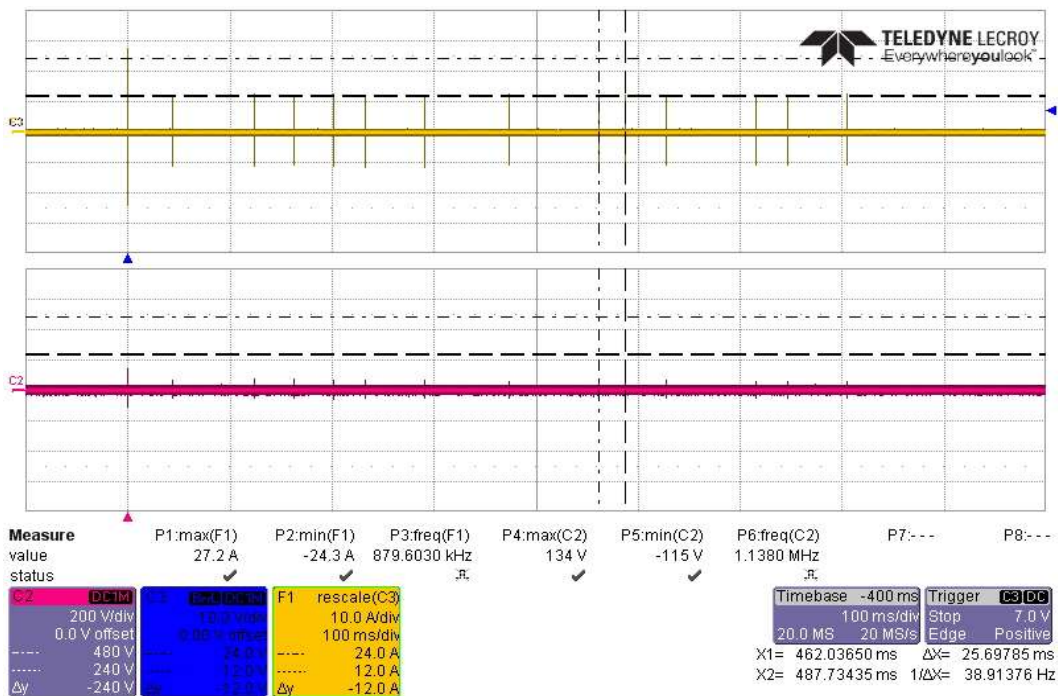

CS117 Current Verification Waveform #3 at 1MHz, 14 Transients +24A/12A

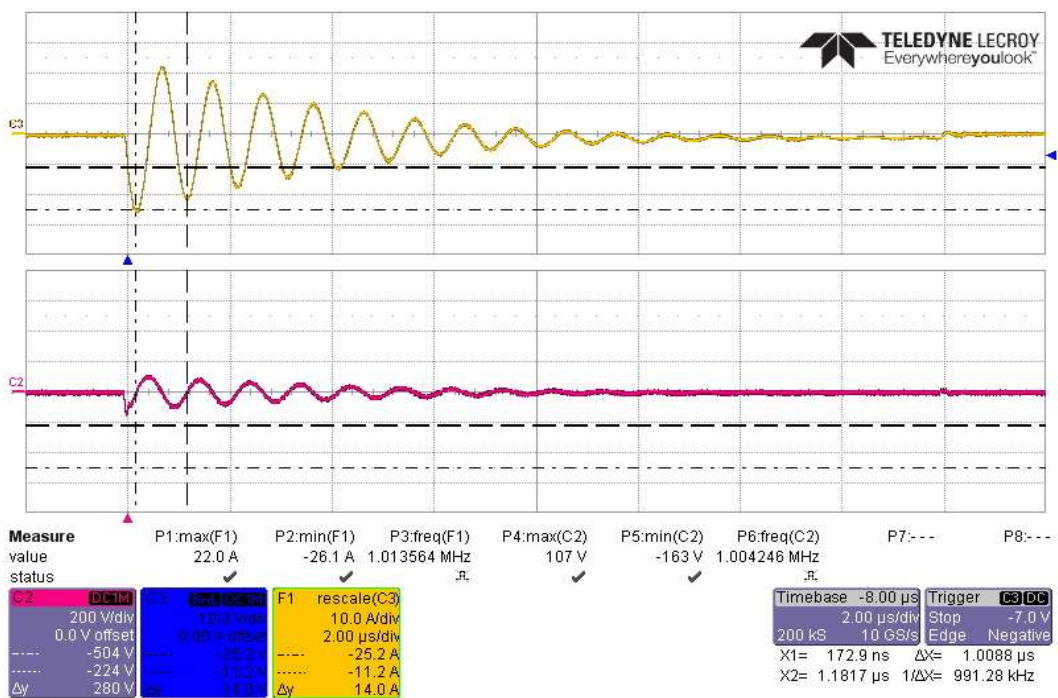

CS117 Current Verification Waveform #3 at 1MHz, First Transient -24A

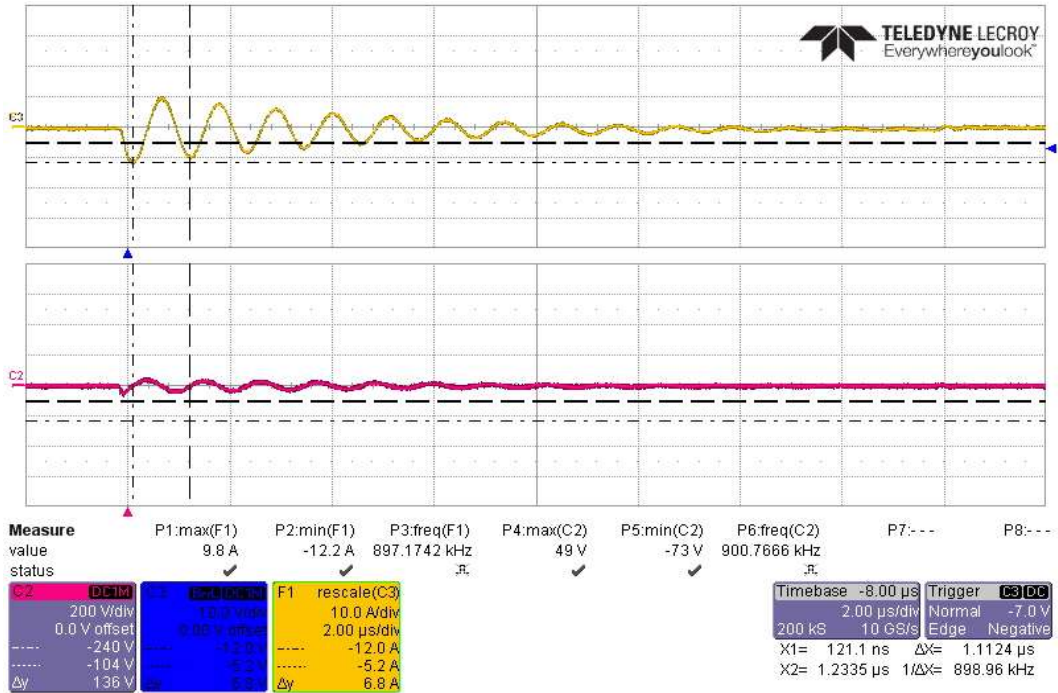

CS117 Current Verification Waveform #3 at 1MHz, Subsequent Transient -12A

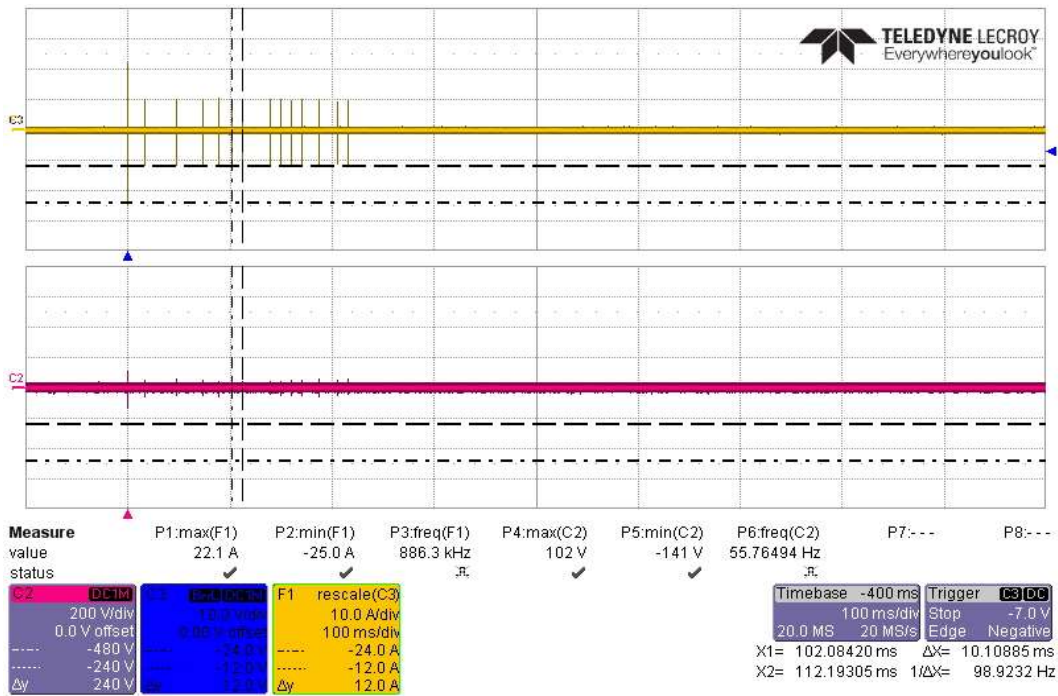

CS117 Current Verification Waveform #3 at 1MHz, 14 Transients -24A/12A

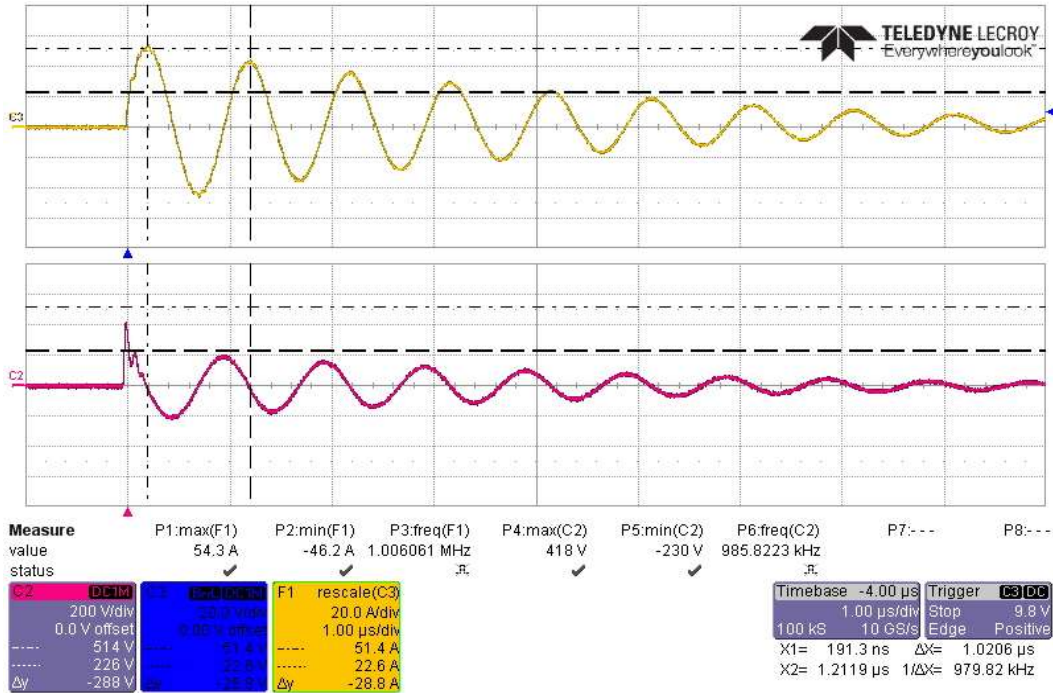

CS117 Current Verification Waveform #3 at 1MHz, First Transient +48A

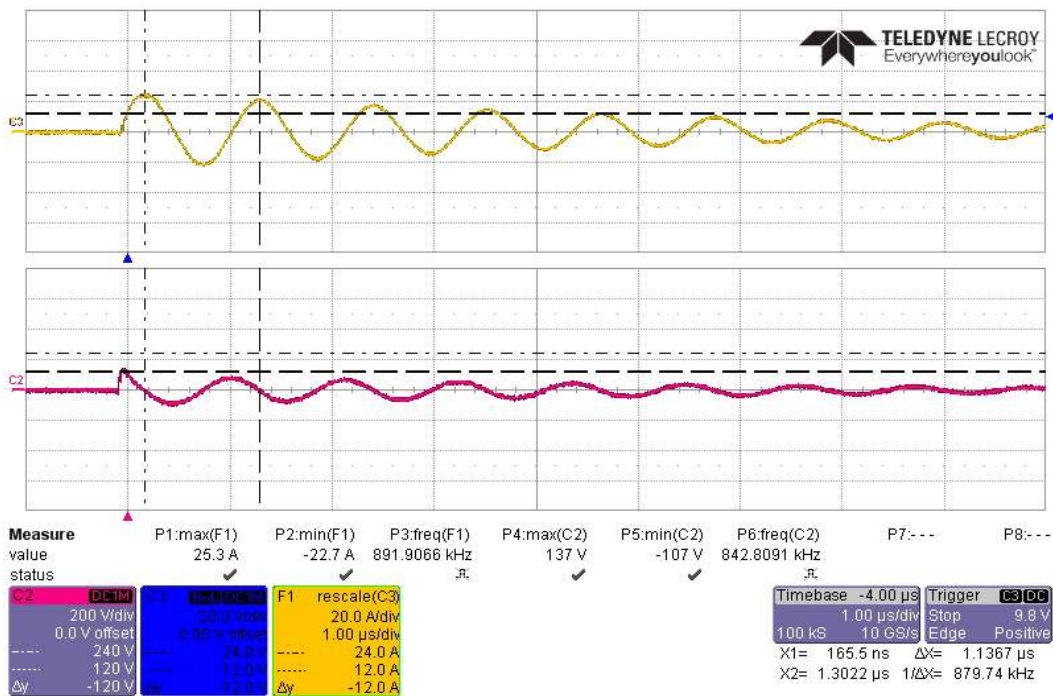

CS117 Current Verification Waveform #3 at 1MHz, Subsequent Transient +24A

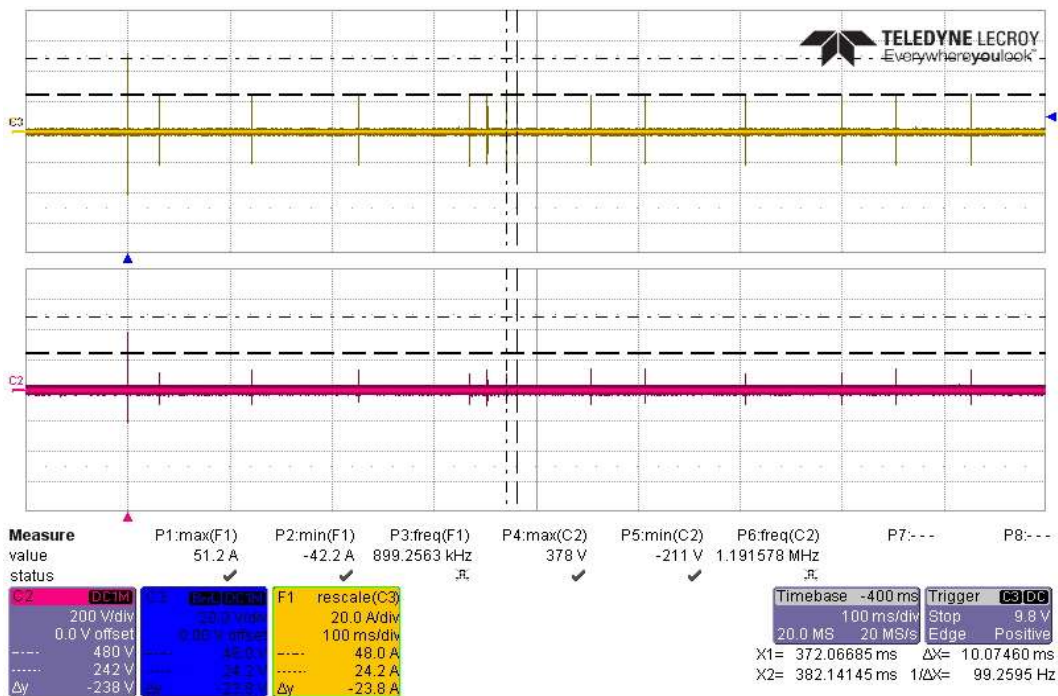

CS117 Current Verification Waveform #3 at 1MHz, 14 Transients +48A/24A

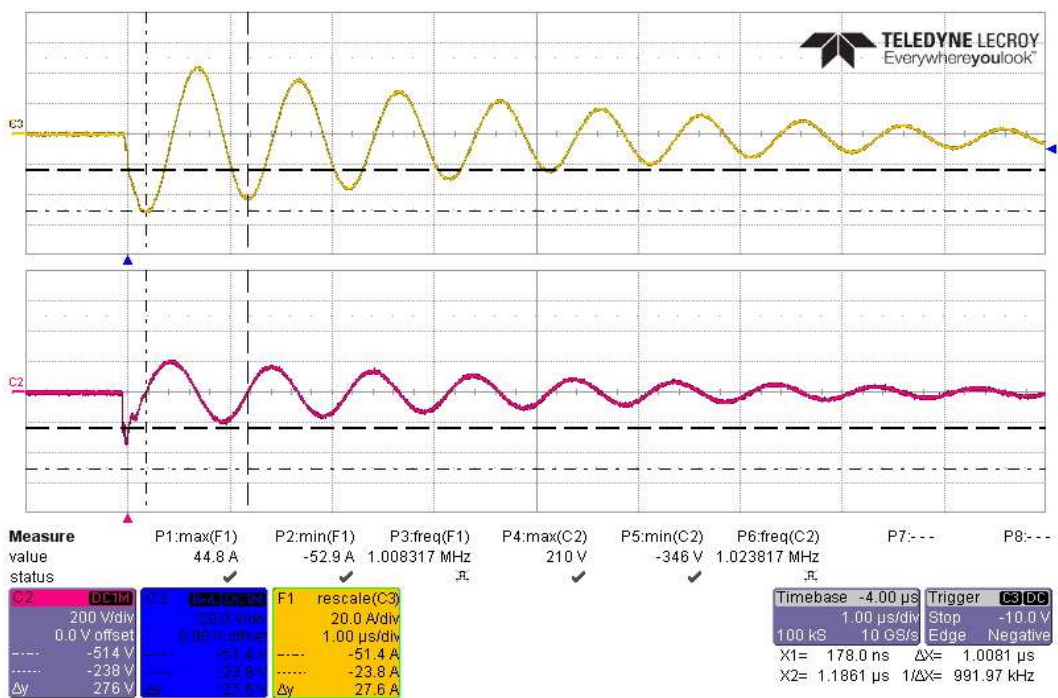

CS117 Current Verification Waveform #3 at 1MHz, First Transient -48A

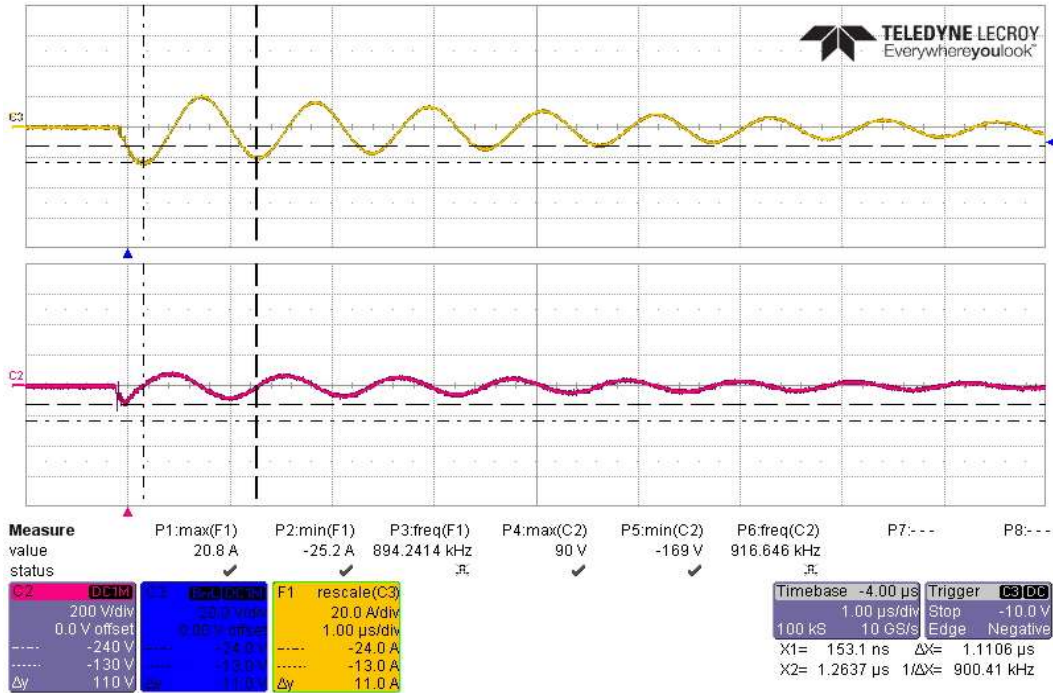

CS117 Current Verification Waveform #3 at 1MHz, Subsequent Transient -24A

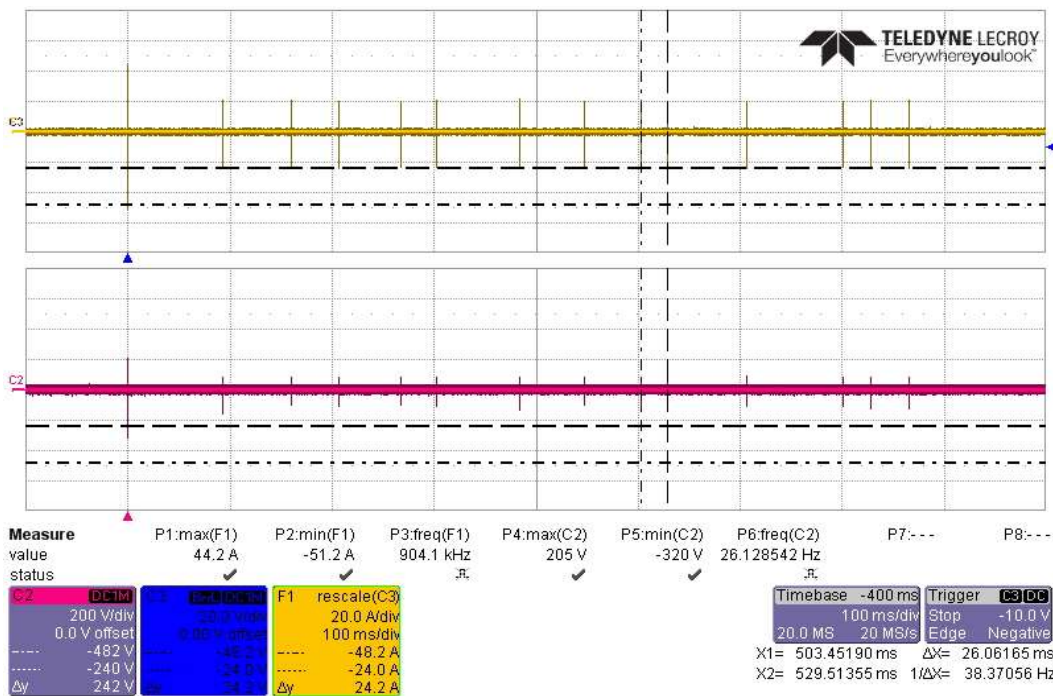

CS117 Current Verification Waveform #3 at 1MHz, 14 Transients -48A/24A

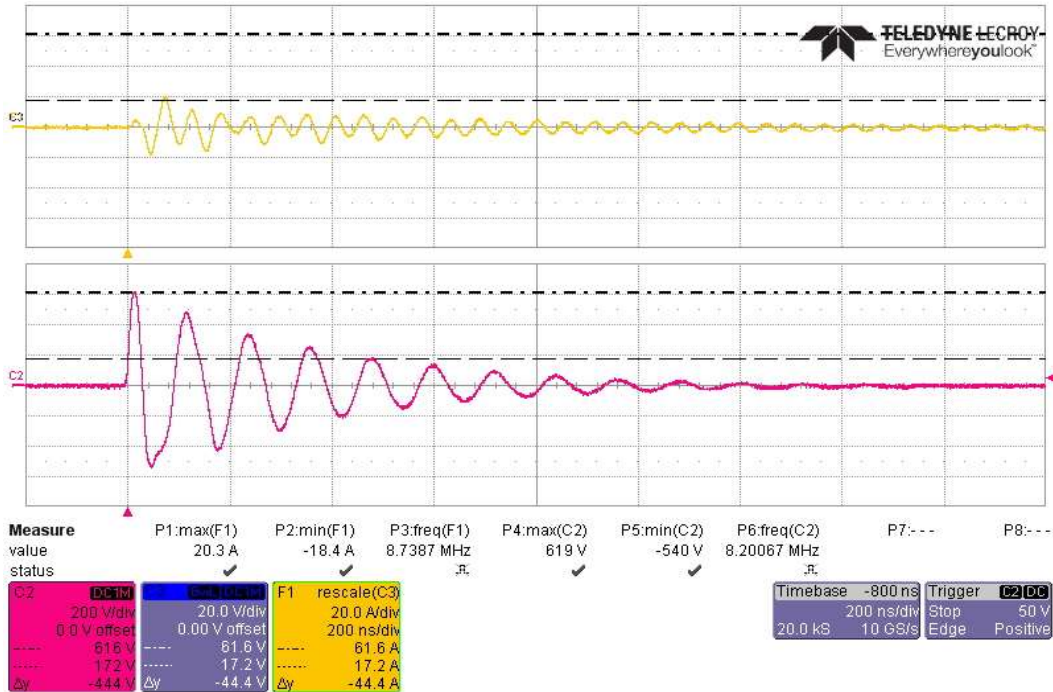
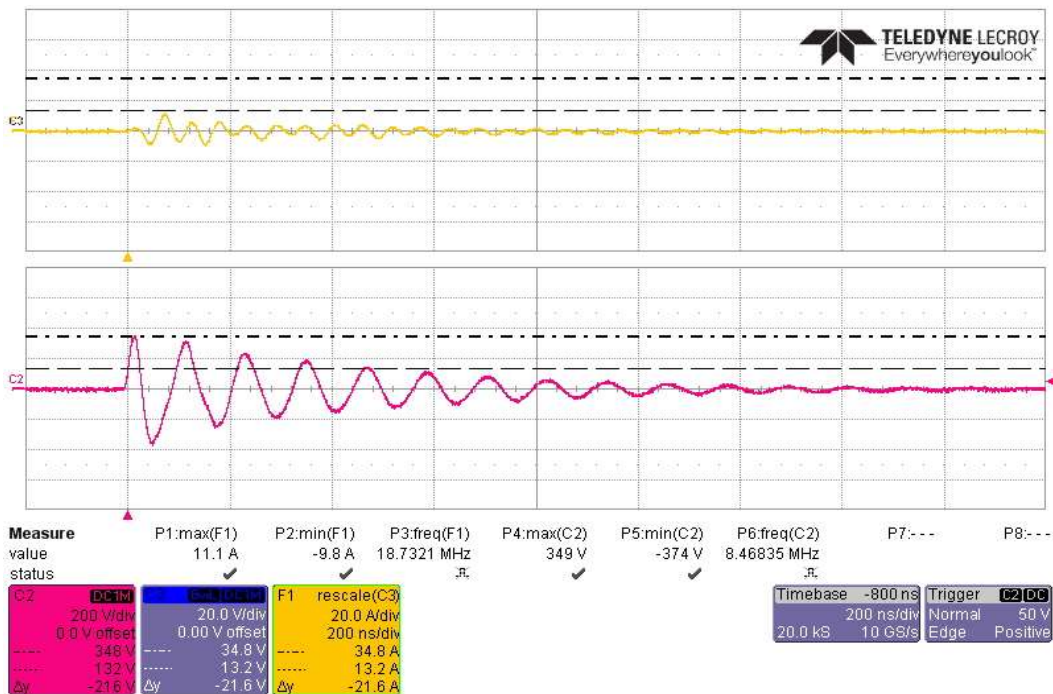
CS117 Voltage and Current Verification Multiple Stroke Waveform #3 at 10MHz with 600V/24A/48A

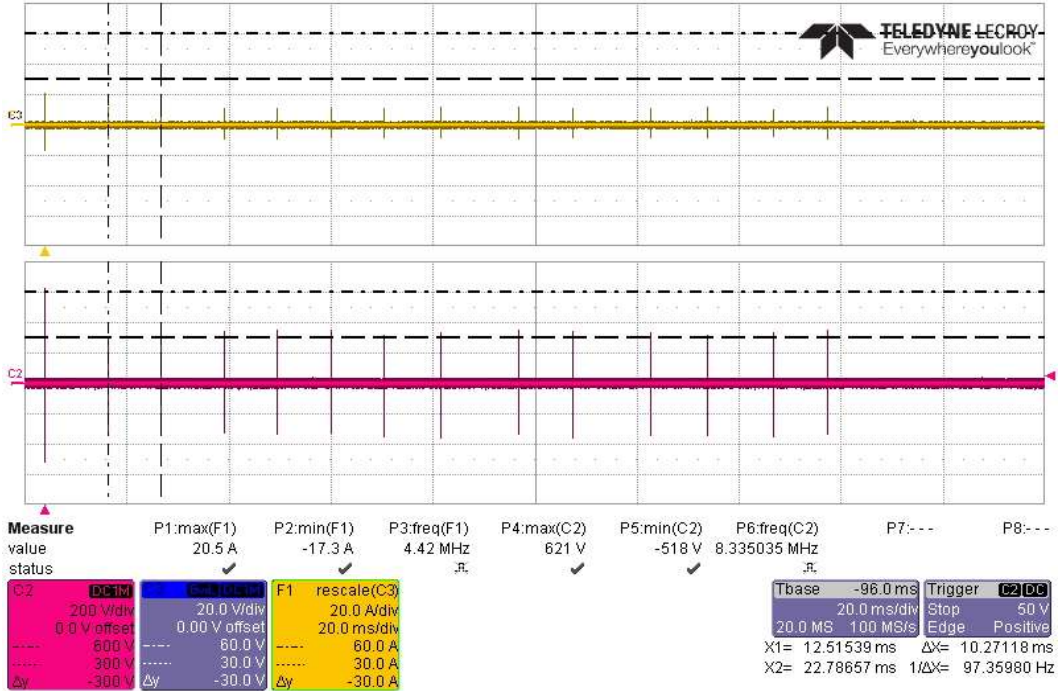
CS117 Voltage Verification Waveform #3 at 10MHz, First Transient +600V

CS117 Voltage Verification Waveform #3 at 10MHz, Subsequent Transient +300V

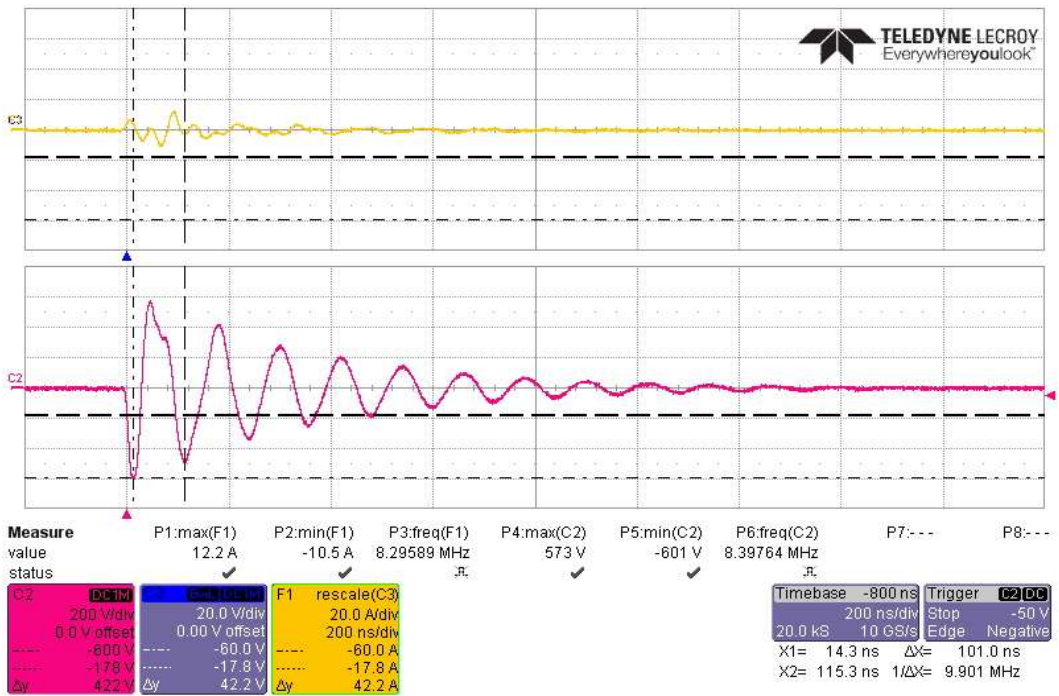

CS117 Voltage Verification Waveform #3 at 10MHz, 14 Transients +600V/300V

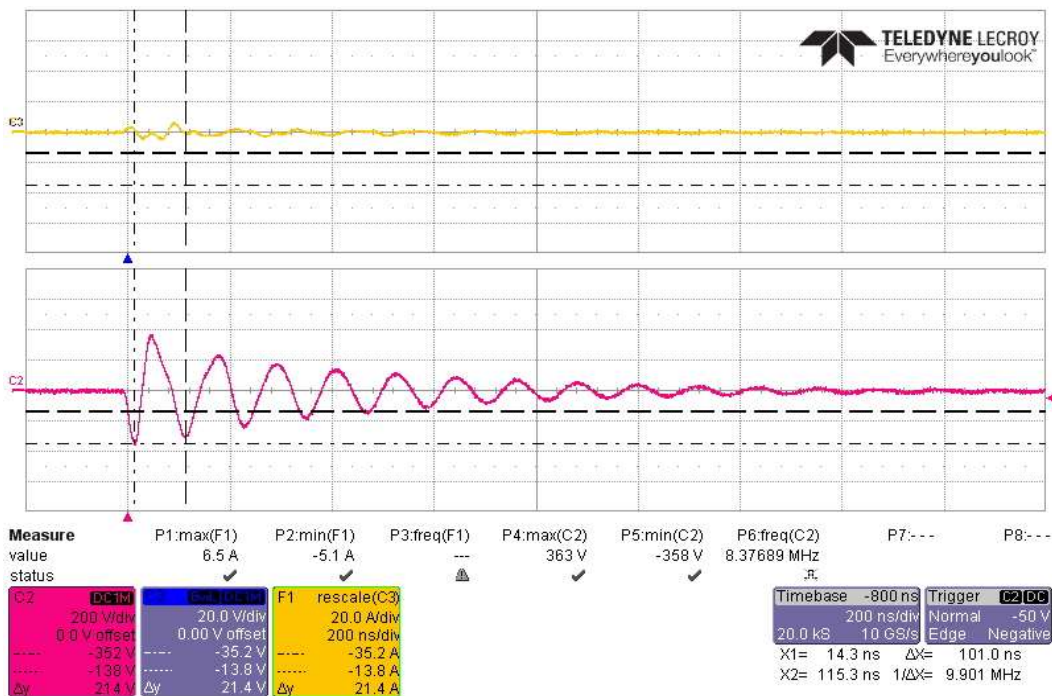

CS117 Voltage Verification Waveform #3 at 10MHz, First Transient -600V



CS117 Voltage Verification Waveform #3 at 10MHz, Subsequent Transient -300V

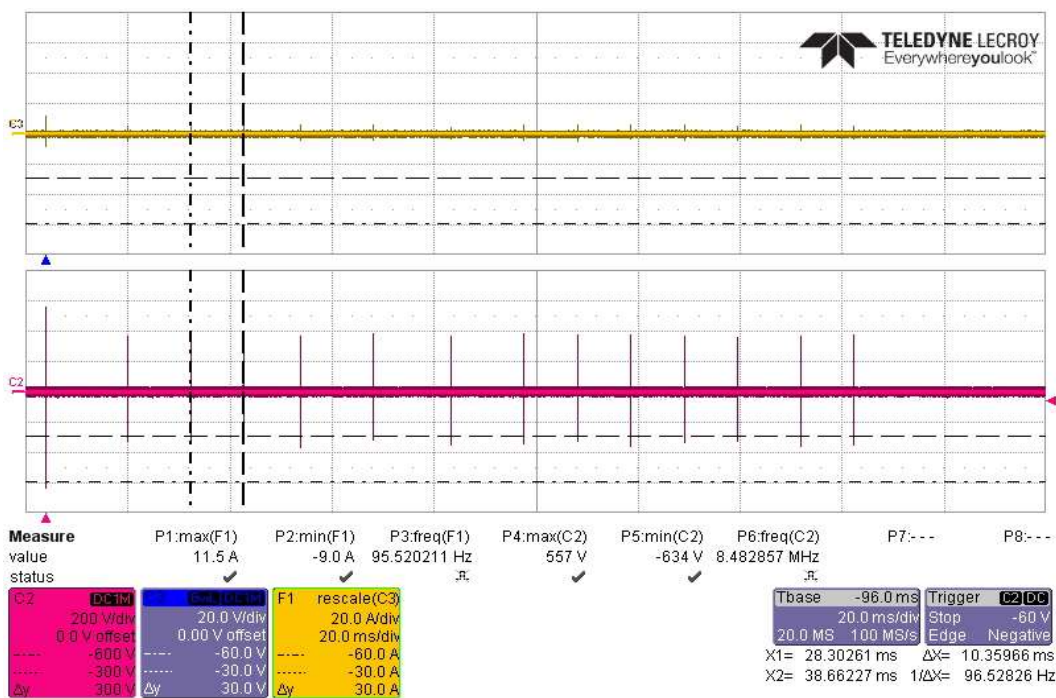

CS117 Voltage Verification Waveform #3 at 10MHz, 14 Transients -600V/300V

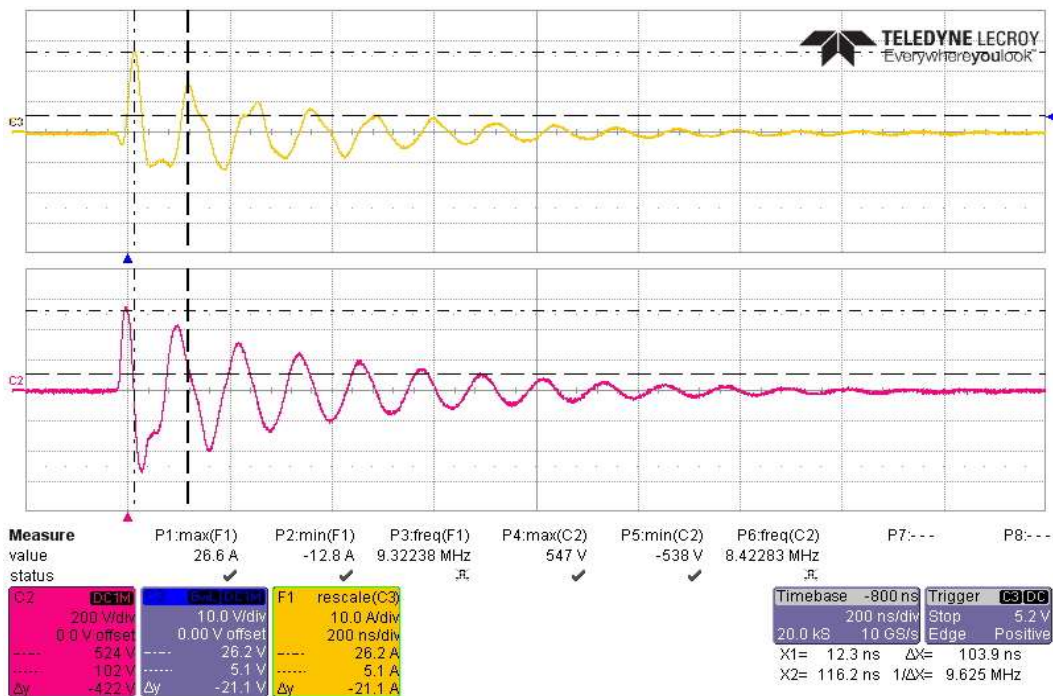

CS117 Current Verification Waveform #3 at 10MHz, First Transient +24A

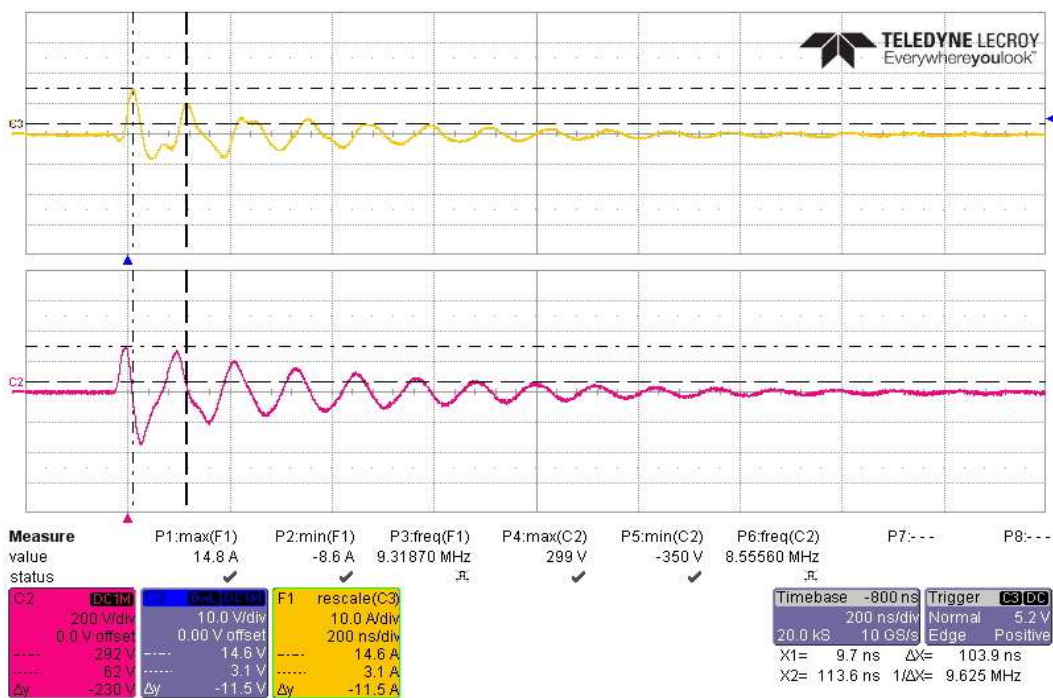

CS117 Current Verification Waveform #3 at 10MHz, Subsequent Transient +12A

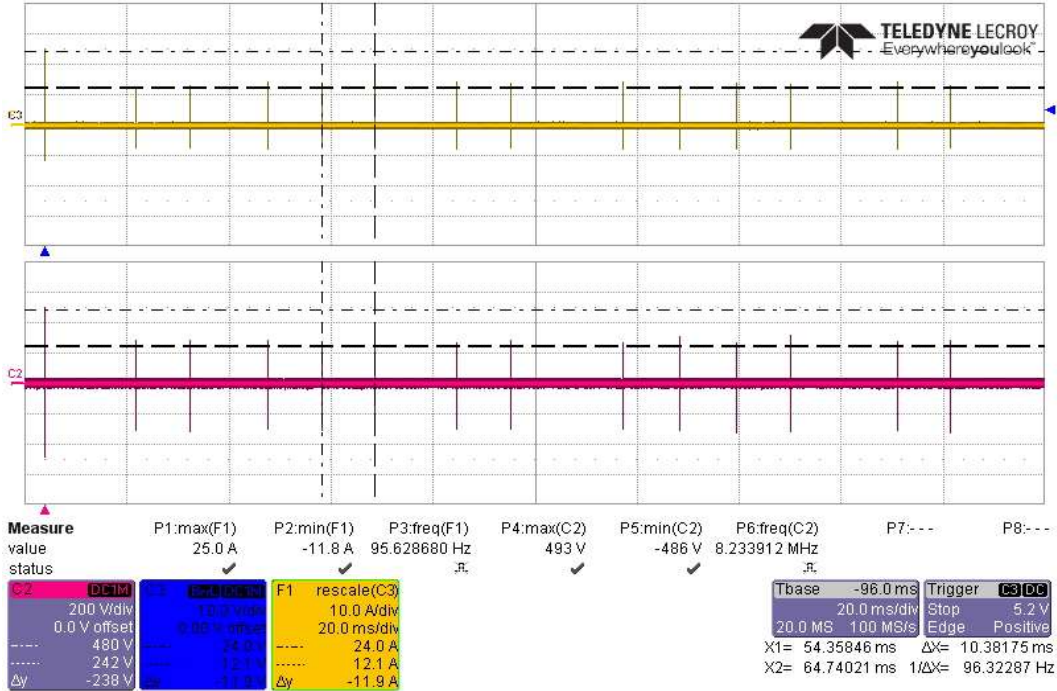

CS117 Current Verification Waveform #3 at 10MHz, 14 Transients +24A/12A

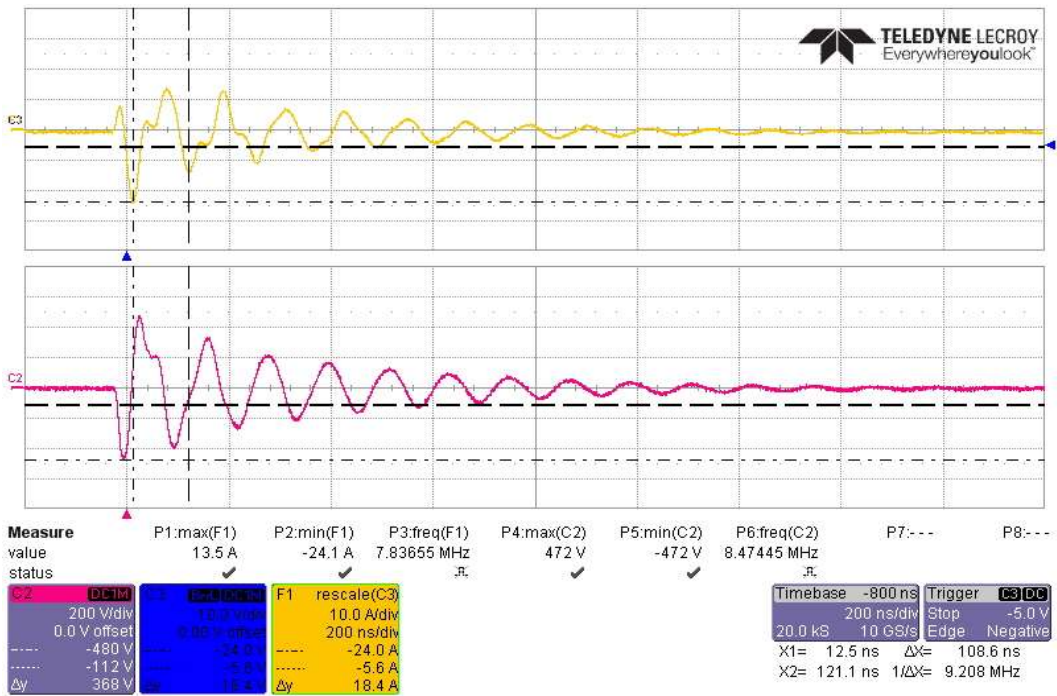

CS117 Current Verification Waveform #3 at 10MHz, First Transient -24A

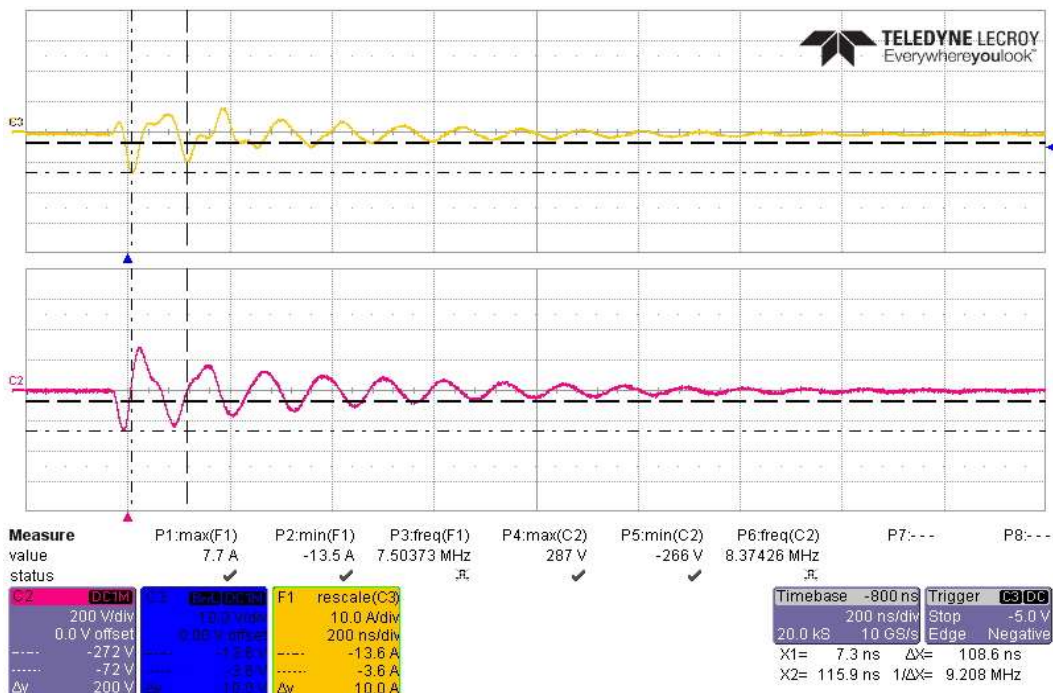

CS117 Current Verification Waveform #3 at 10MHz, Subsequent Transient -12A

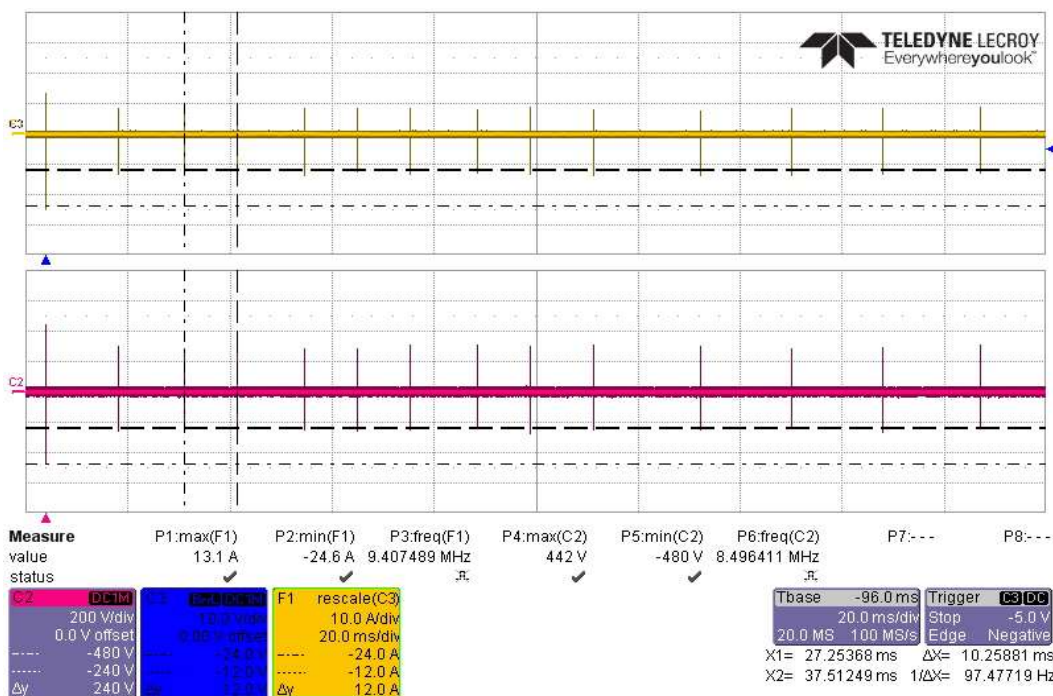

CS117 Current Verification Waveform #3 at 10MHz, 14 Transients -24A/12A

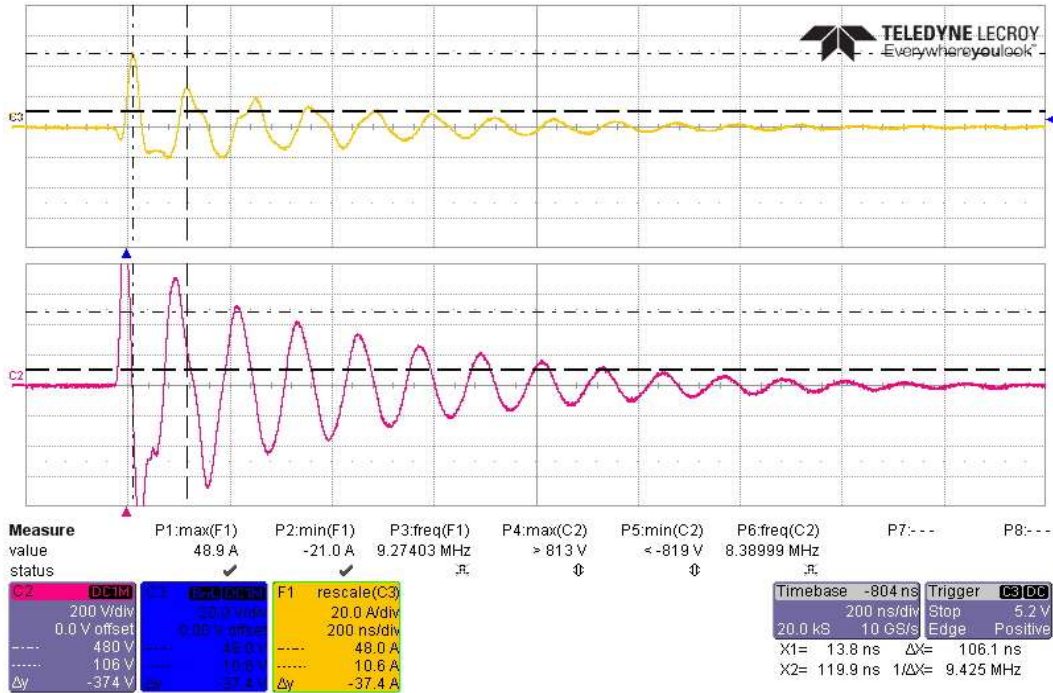

CS117 Current Verification Waveform #3 at 10MHz, First Transient +48A

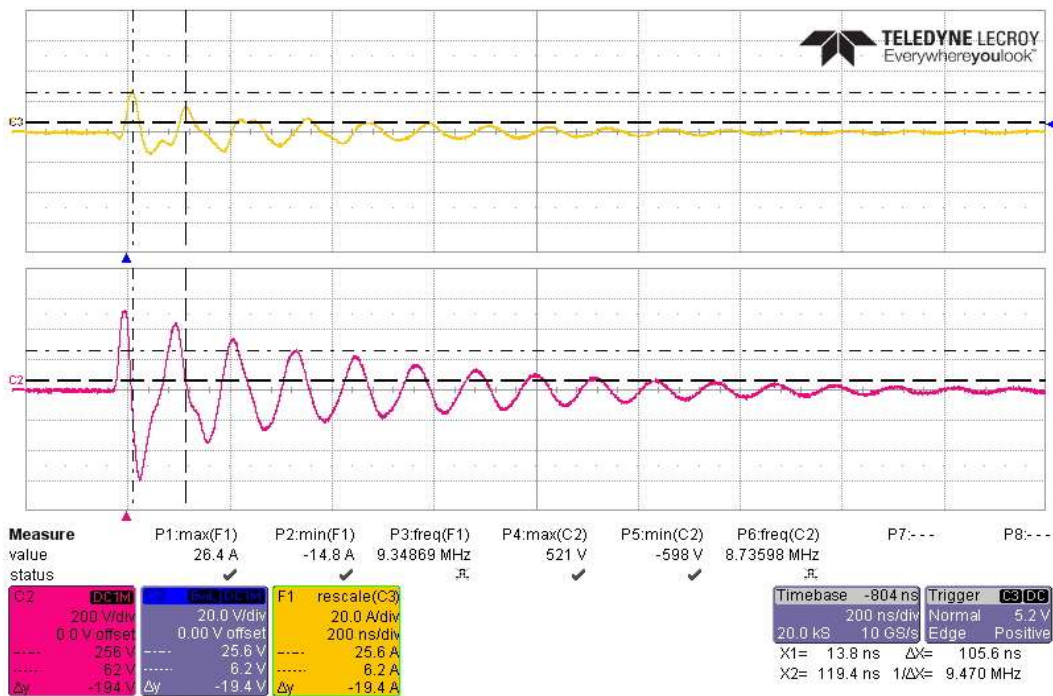

CS117 Current Verification Waveform #3 at 10MHz, Subsequent Transient +24A

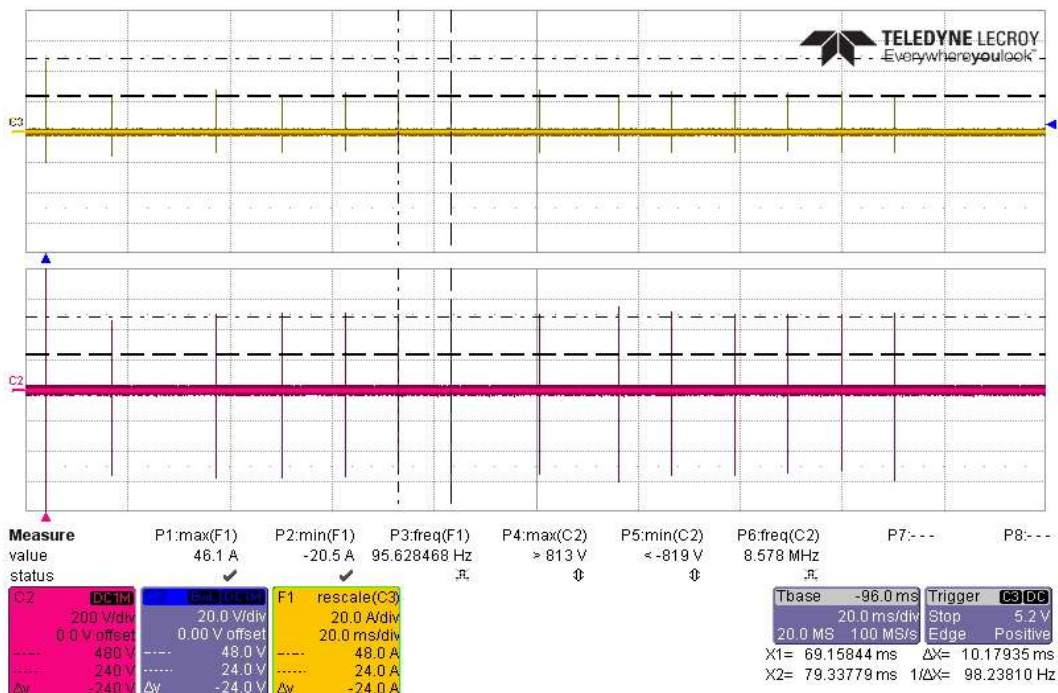

CS117 Current Verification Waveform #3 at 10MHz, 14 Transients +48A/24A

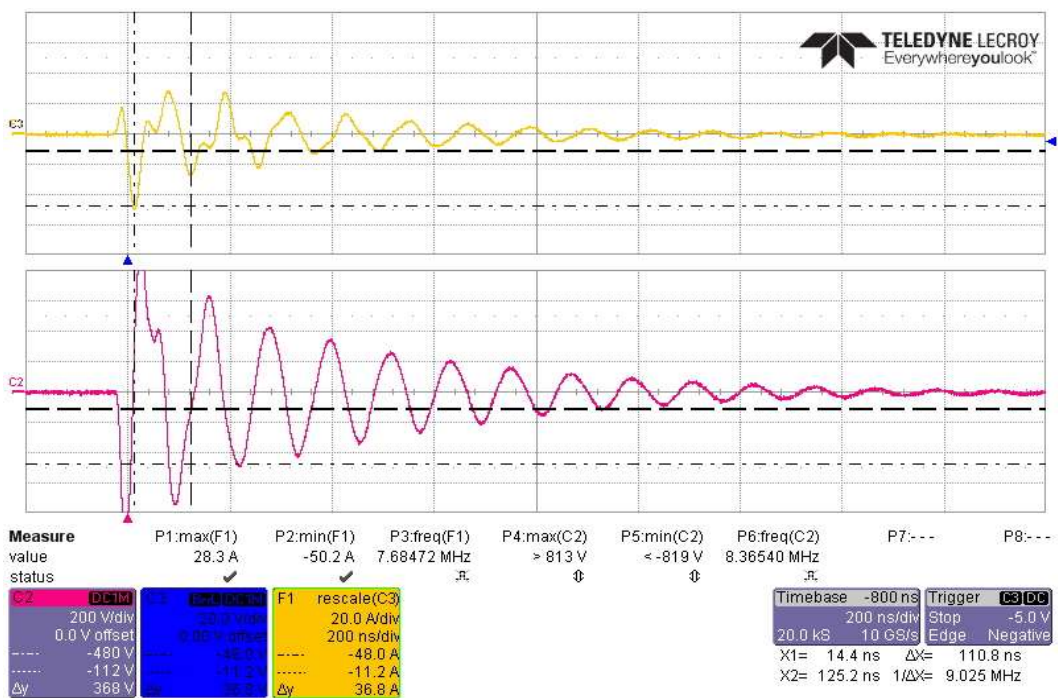

CS117 Current Verification Waveform #3 at 10MHz, First Transient -48A

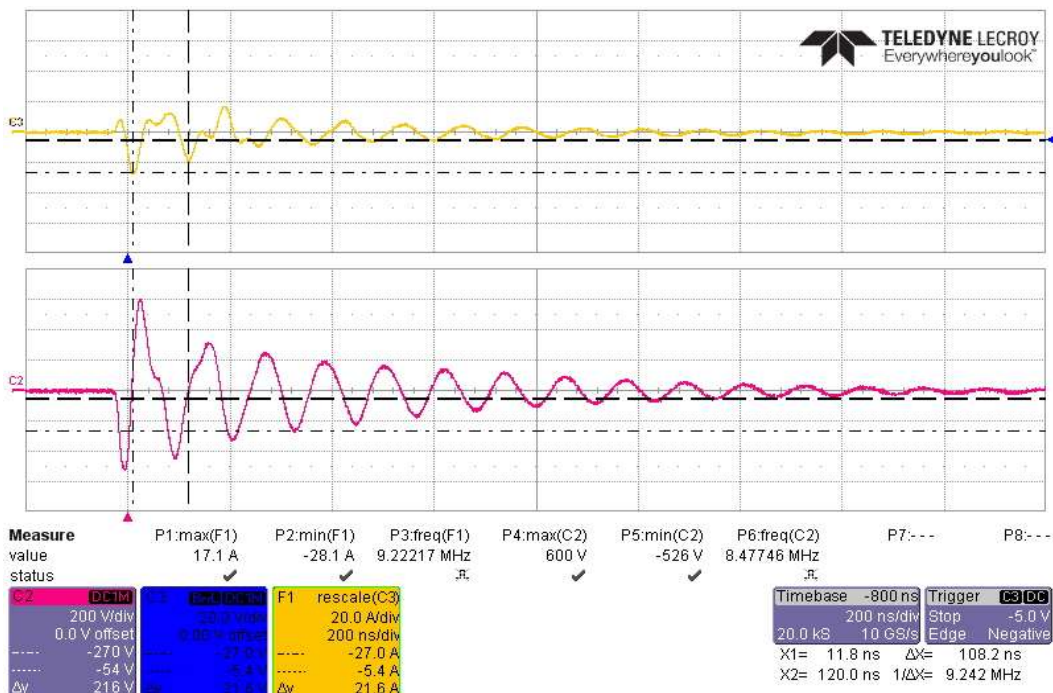

CS117 Current Verification Waveform #3 at 10MHz, Subsequent Transient -24A

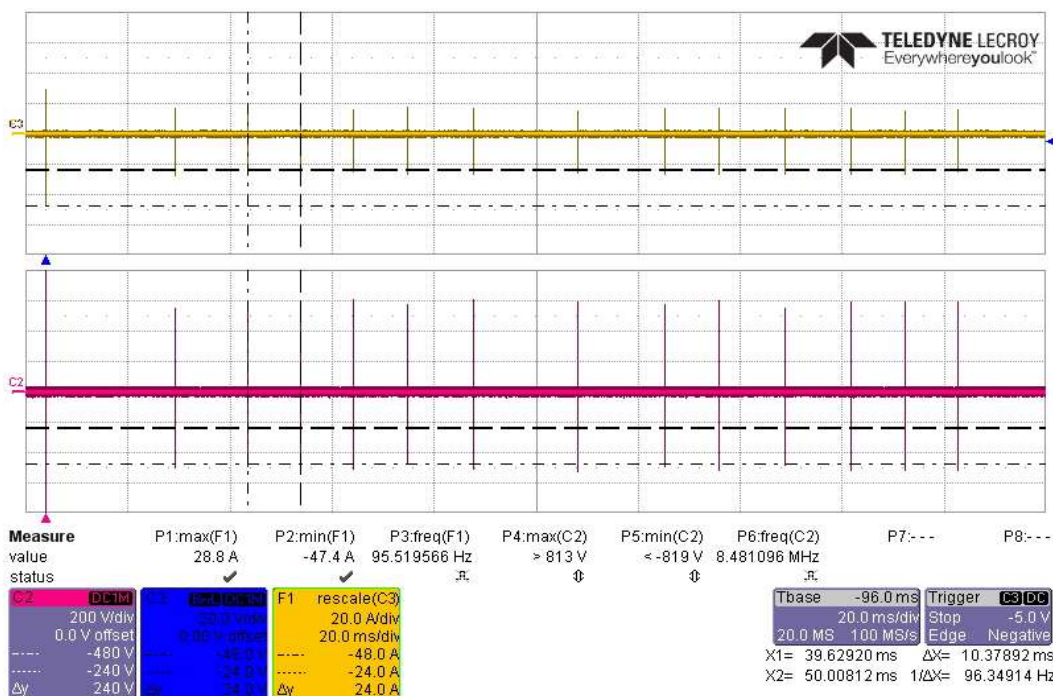

CS117 Current Verification Waveform #3 at 10MHz, 14 Transients -48A/24A

CS117 Voltage and Current Verification Multiple Burst Waveform #3 at 1MHz with 360V/6A

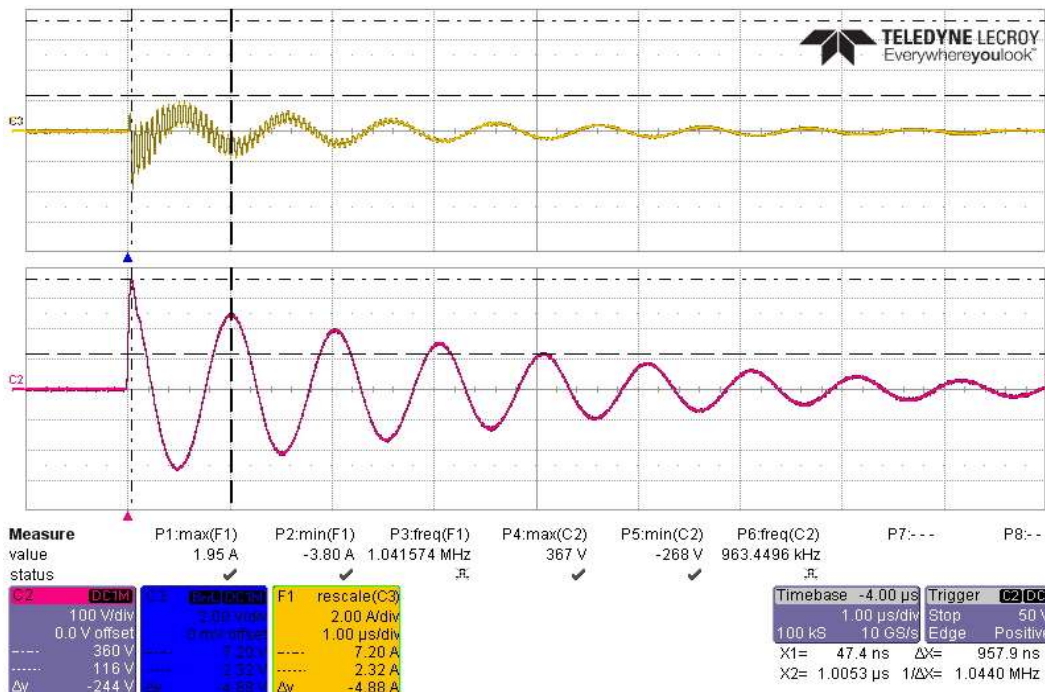

CS117 Voltage Verification Waveform #3 at 1MHz, First Transient at +360V

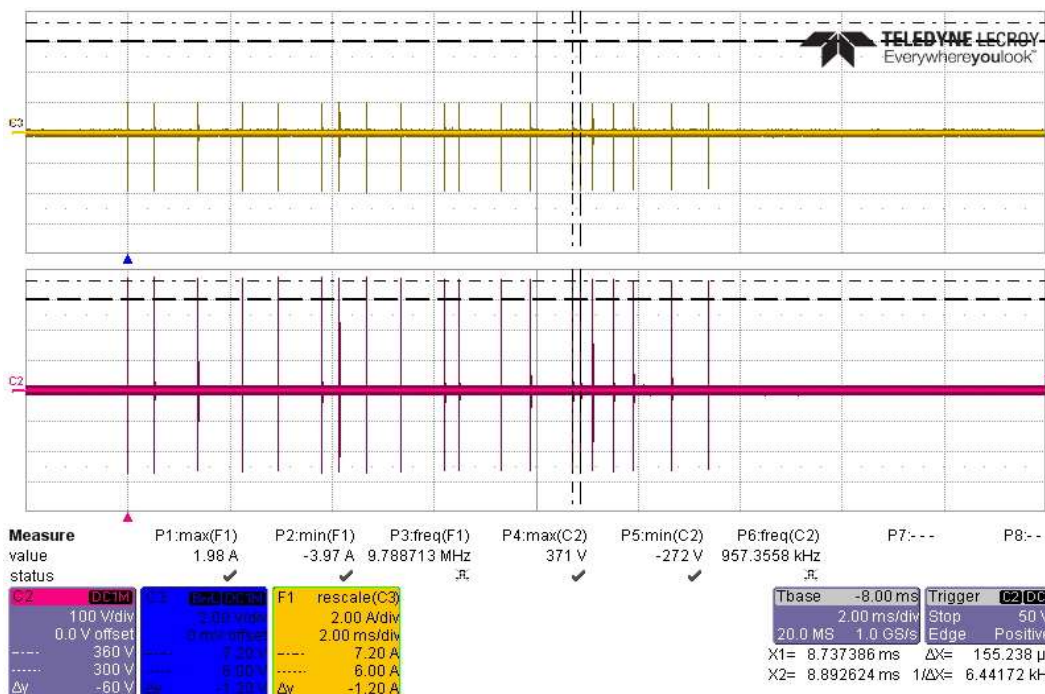

CS117 Voltage Verification Waveform #3 at 1MHz, 20 Transients at +360V

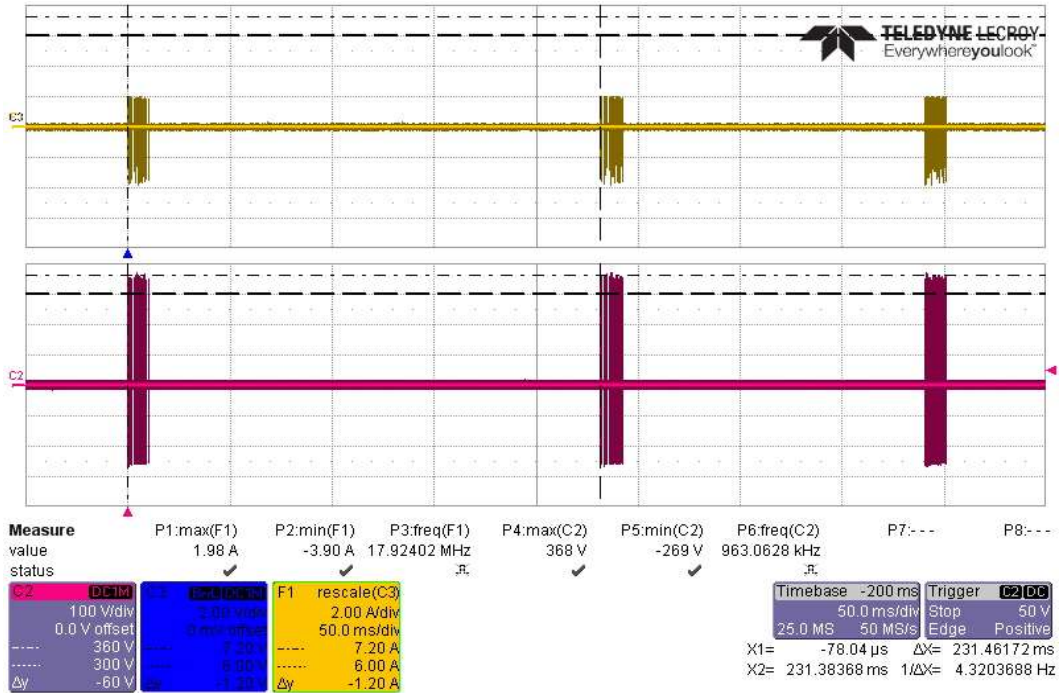

CS117 Voltage Verification Waveform #3 at 1MHz, 3 Bursts at +360V

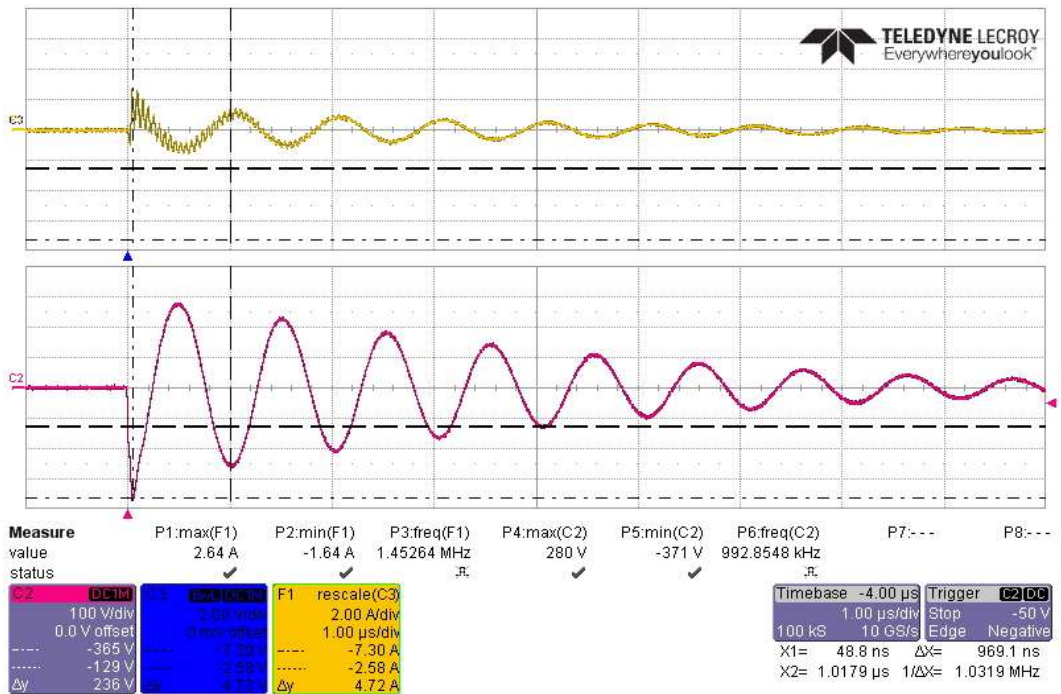

CS117 Voltage Verification Waveform #3 at 1MHz, First Transient at -360V

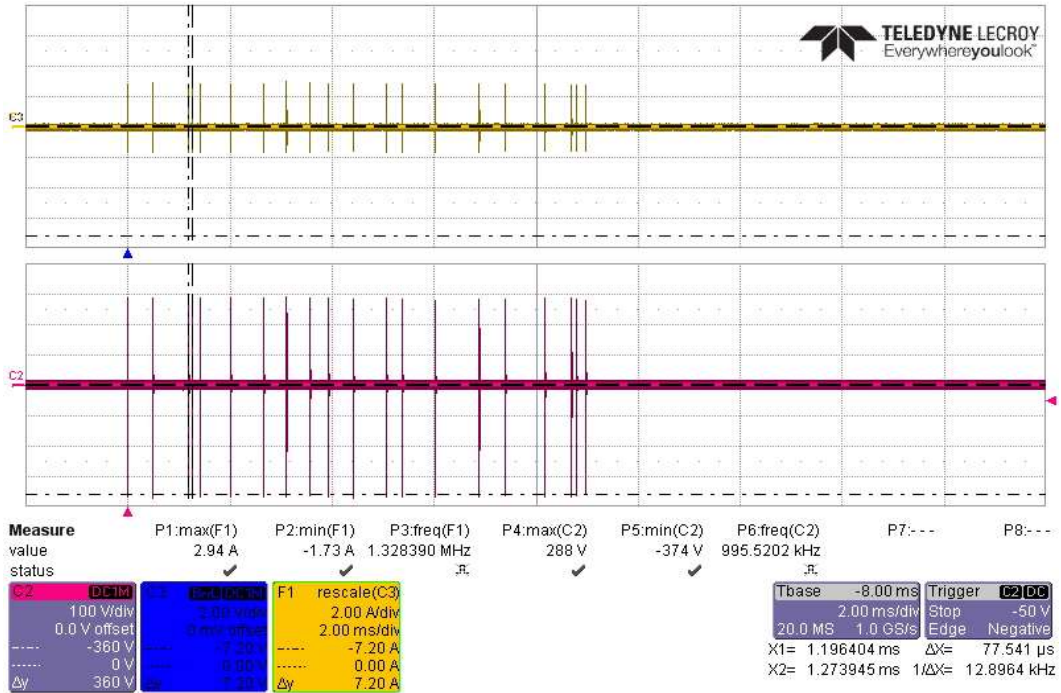

CS117 Voltage Verification Waveform #3 at 1MHz, 20 Transients at -360V

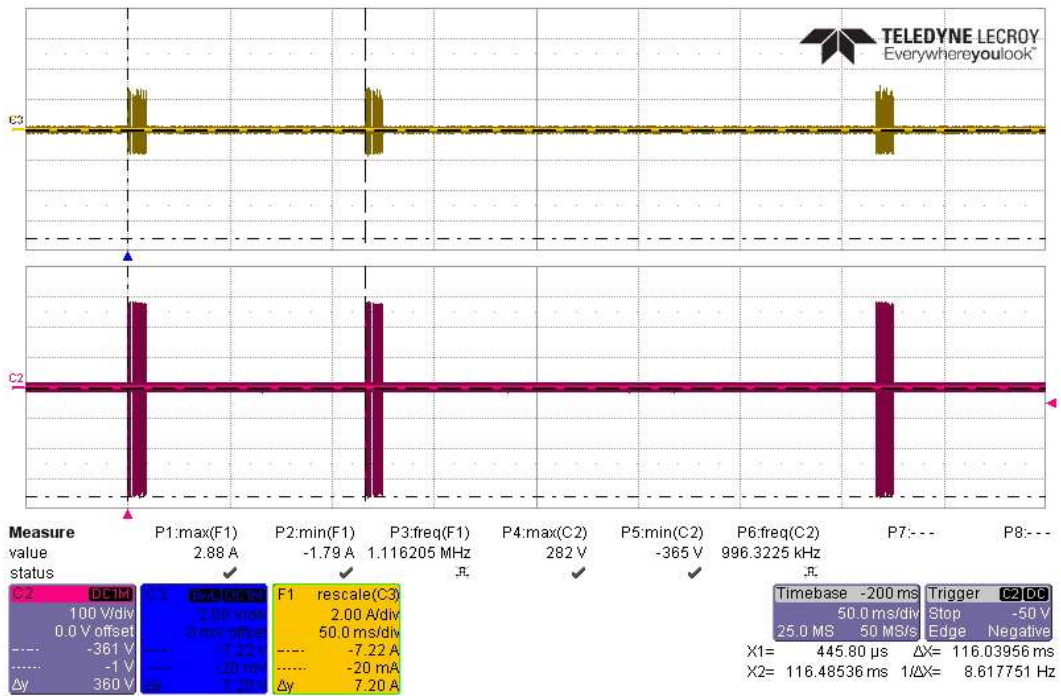

CS117 Voltage Verification Waveform #3 at 1MHz, 3 Bursts at -360V

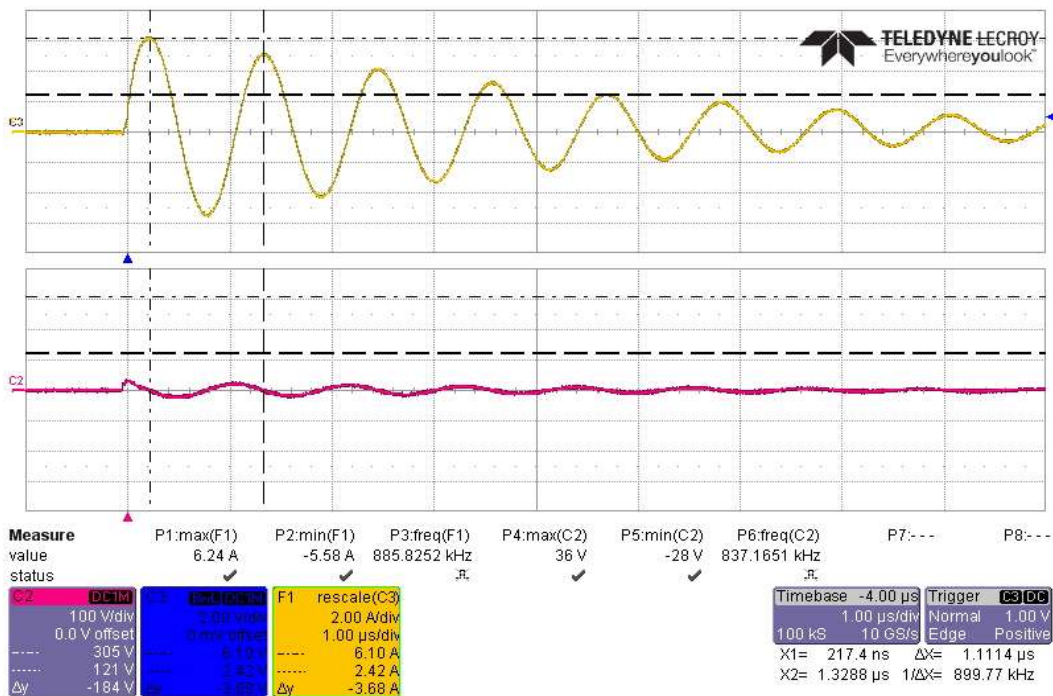

CS117 Current Verification Waveform #3 at 1MHz, First Transient at +6A

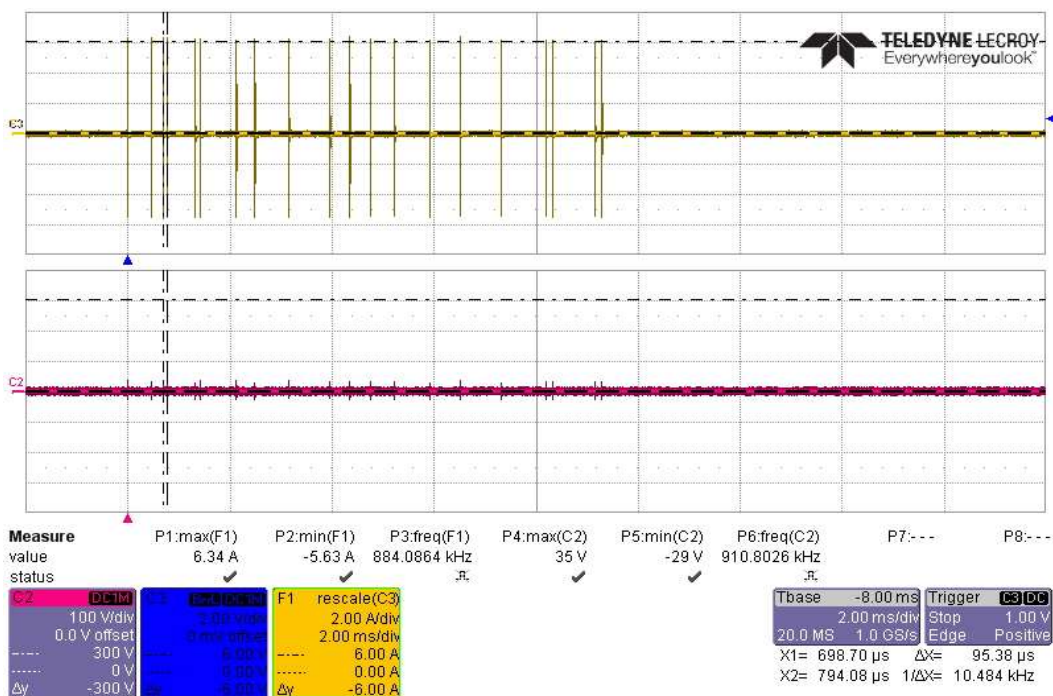

CS117 Current Verification Waveform #3 at 1MHz, 20 Transients at +6A

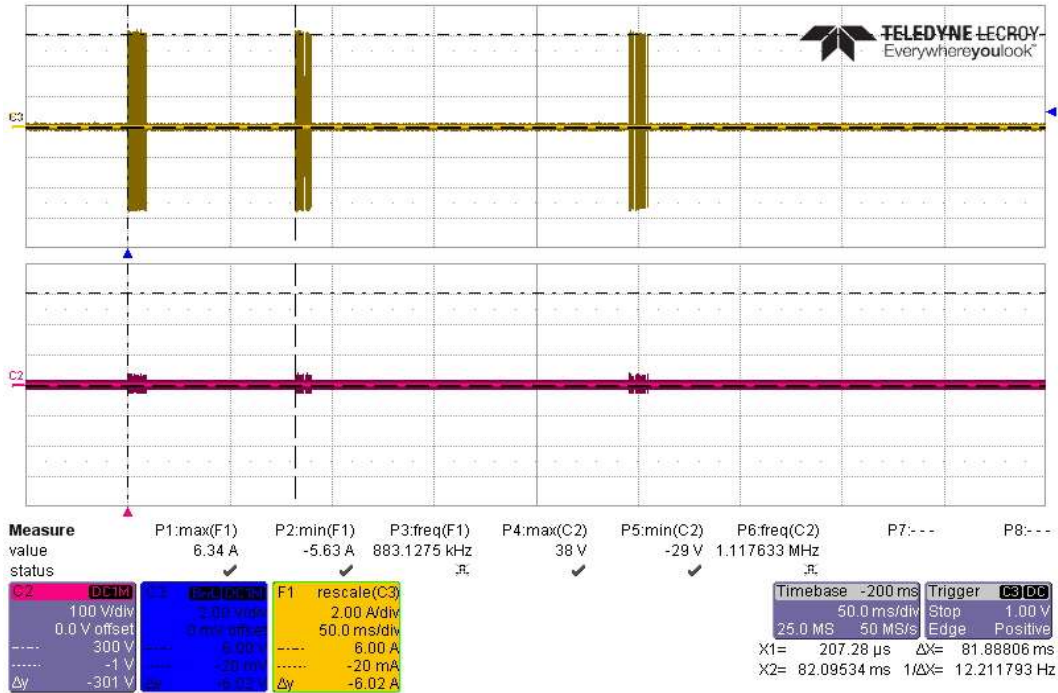

CS117 Current Verification Waveform #3 at 1MHz, 3 Bursts at +6A

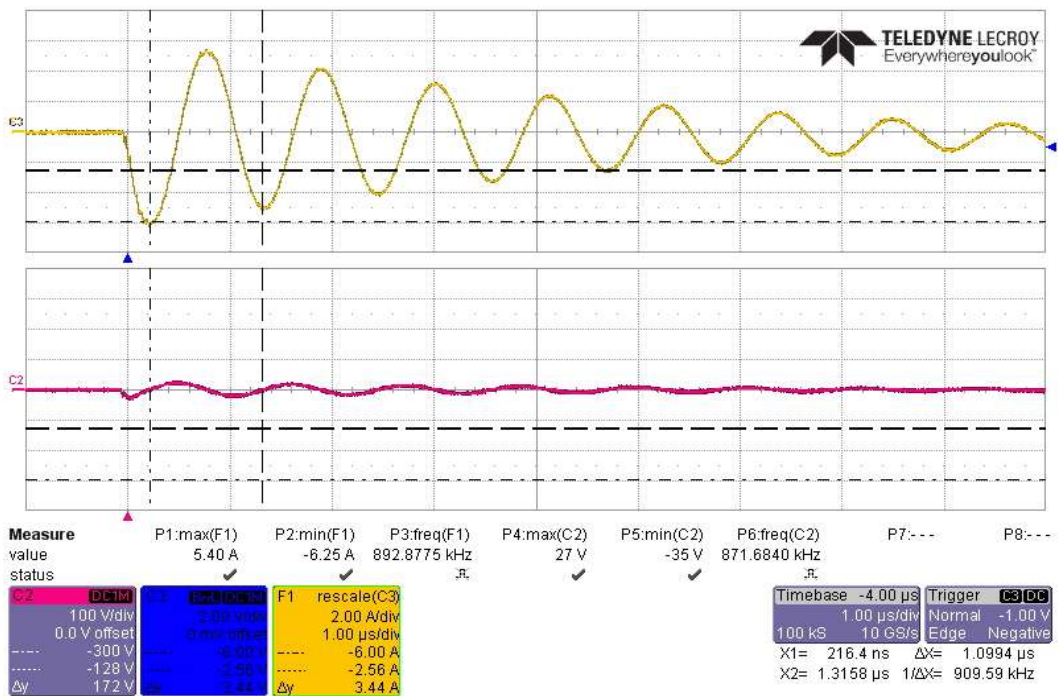

CS117 Current Verification Waveform #3 at 1MHz, First Transient at -6A

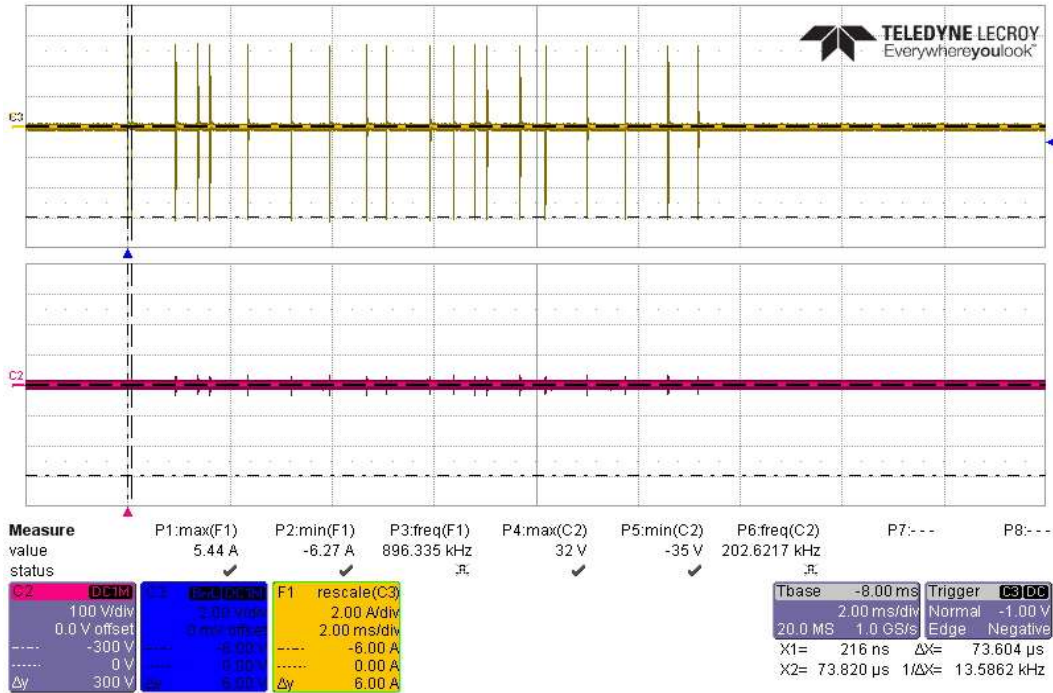

CS117 Current Verification Waveform #3 at 1MHz, 20 Transients at -6A

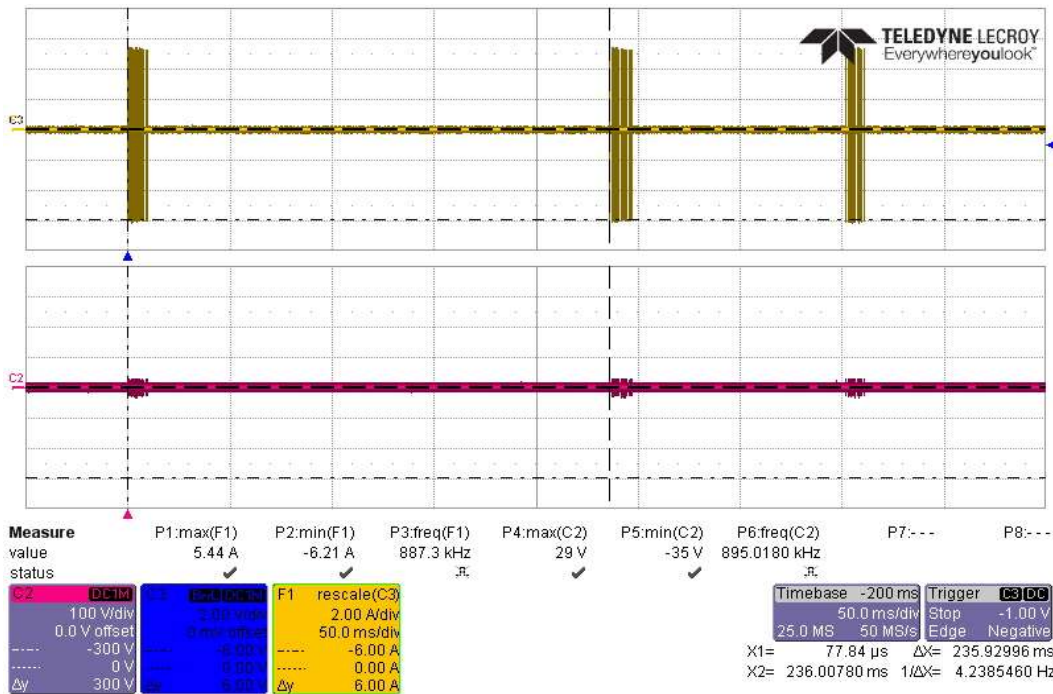

CS117 Current Verification Waveform #3 at 1MHz, 3 Bursts at -6A

CS117 Voltage and Current Verification Multiple Burst Waveform #3 at 10MHz with 360V/6A

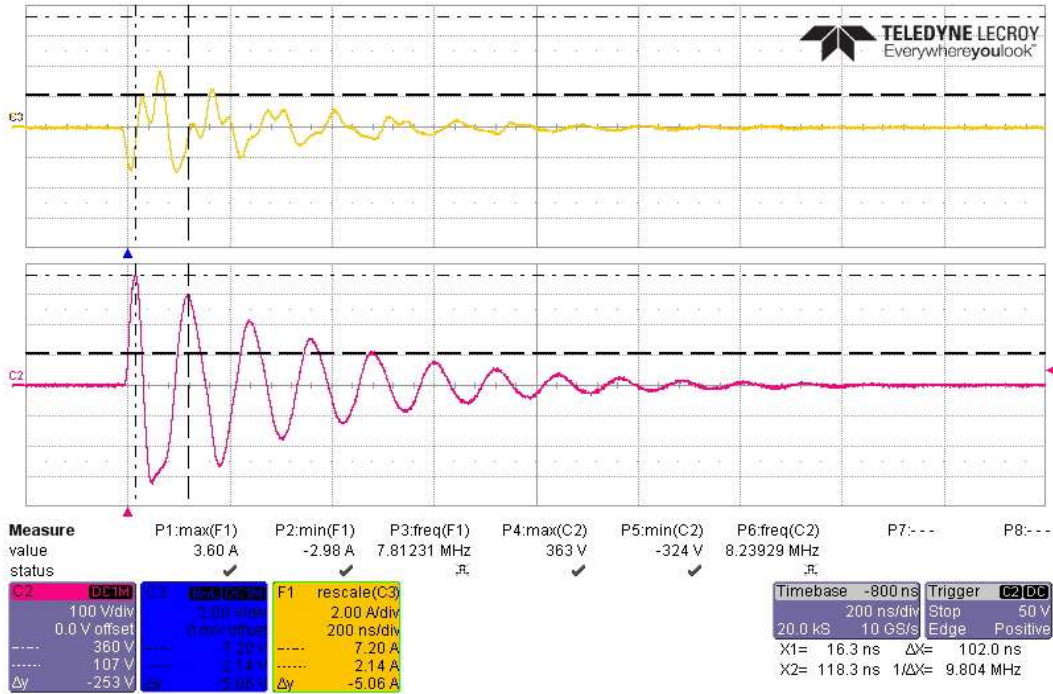

CS117 Voltage Verification Waveform #3 at 10MHz, First Transient at +360V

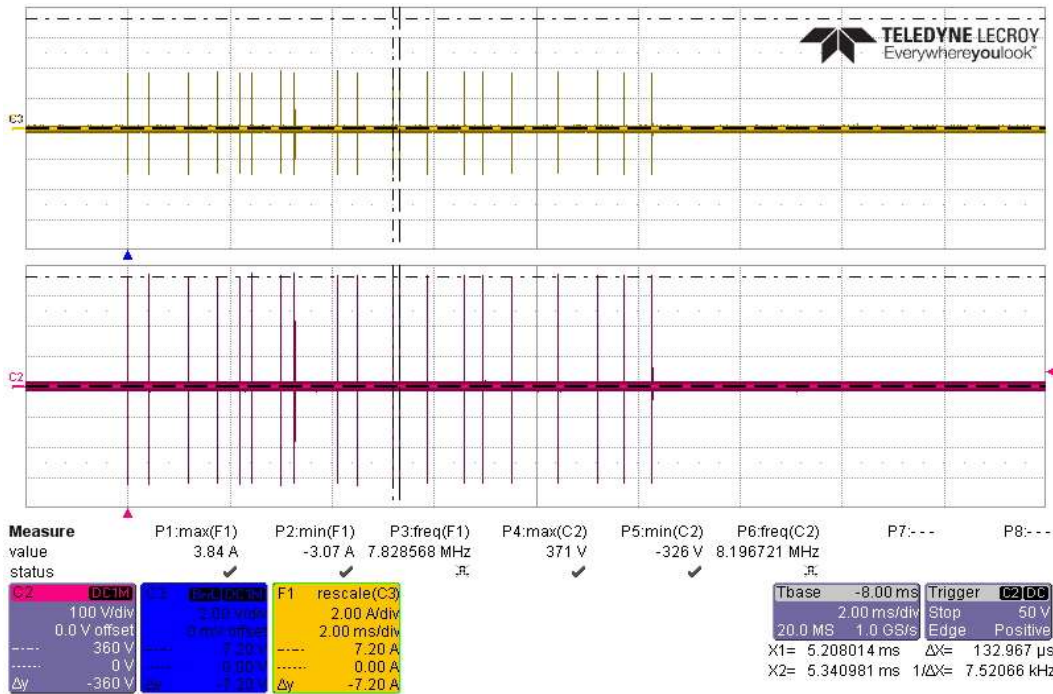

CS117 Voltage Verification Waveform #3 at 10MHz, 20 Transients at +360V

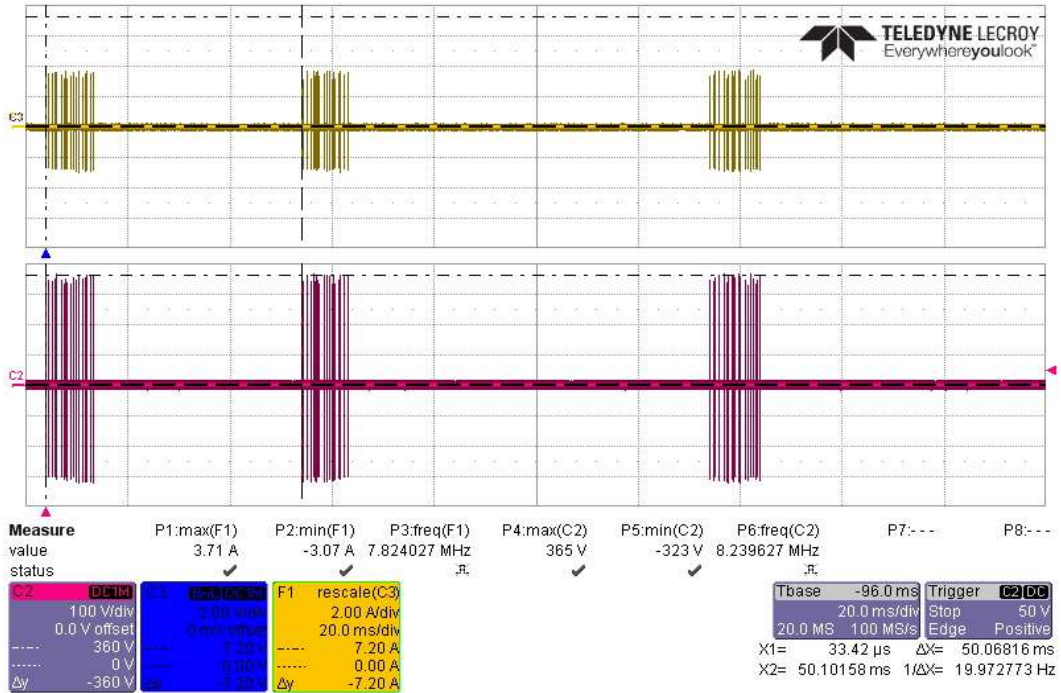

CS117 Voltage Verification Waveform #3 at 10MHz, 3 Bursts at +360V

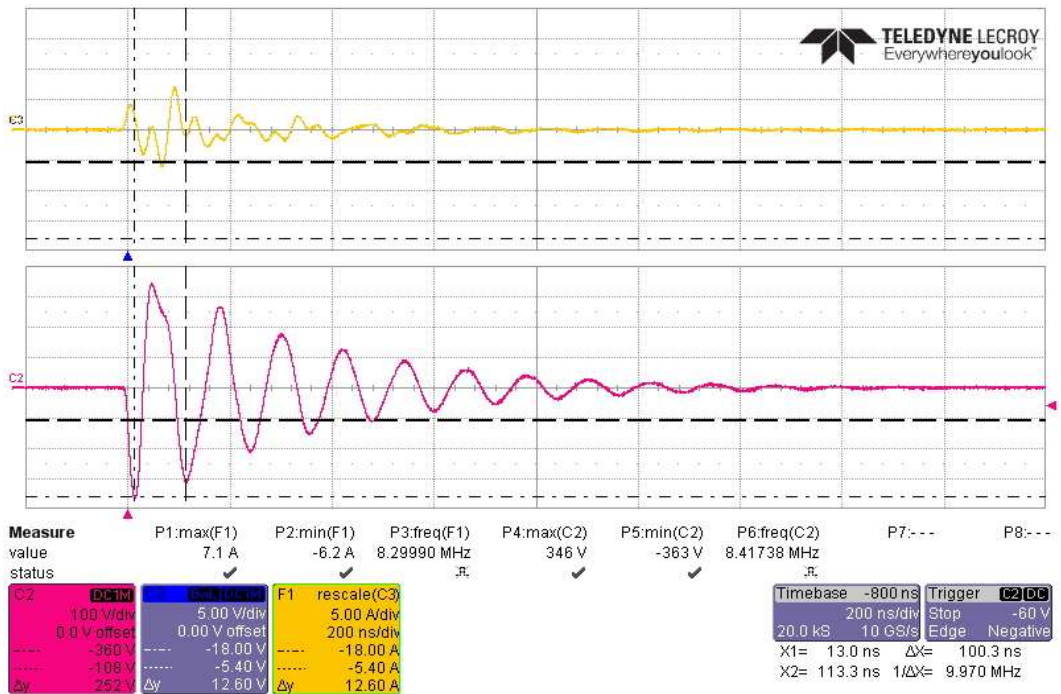

CS117 Voltage Verification Waveform #3 at 10MHz, First Transient at -360V

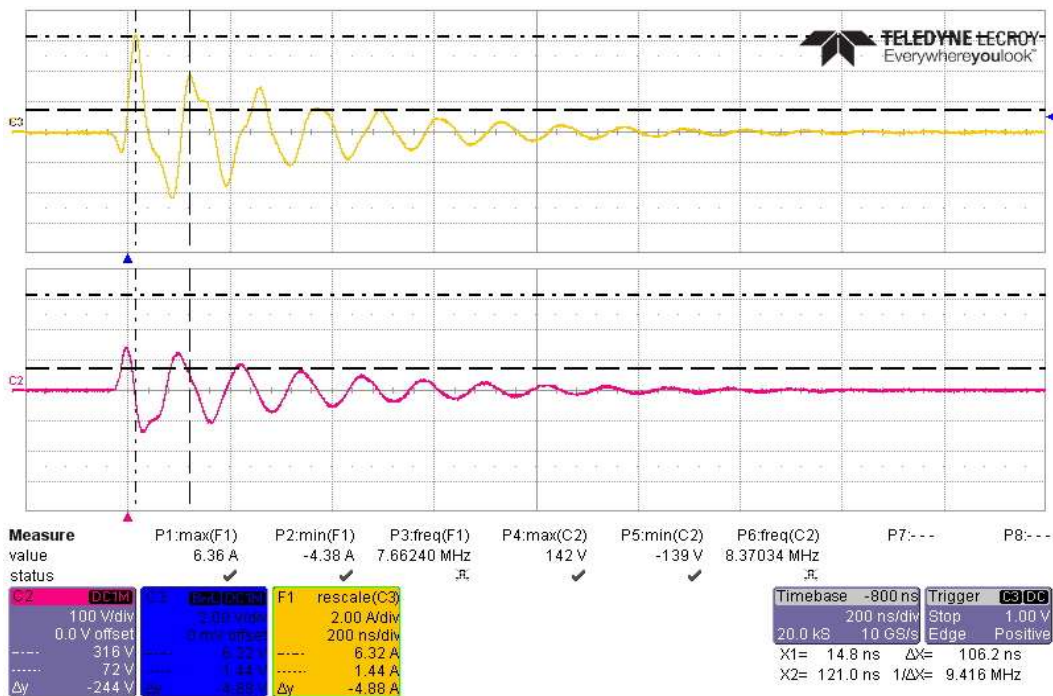

CS117 Current Verification Waveform #3 at 10MHz, First Transient at +6A

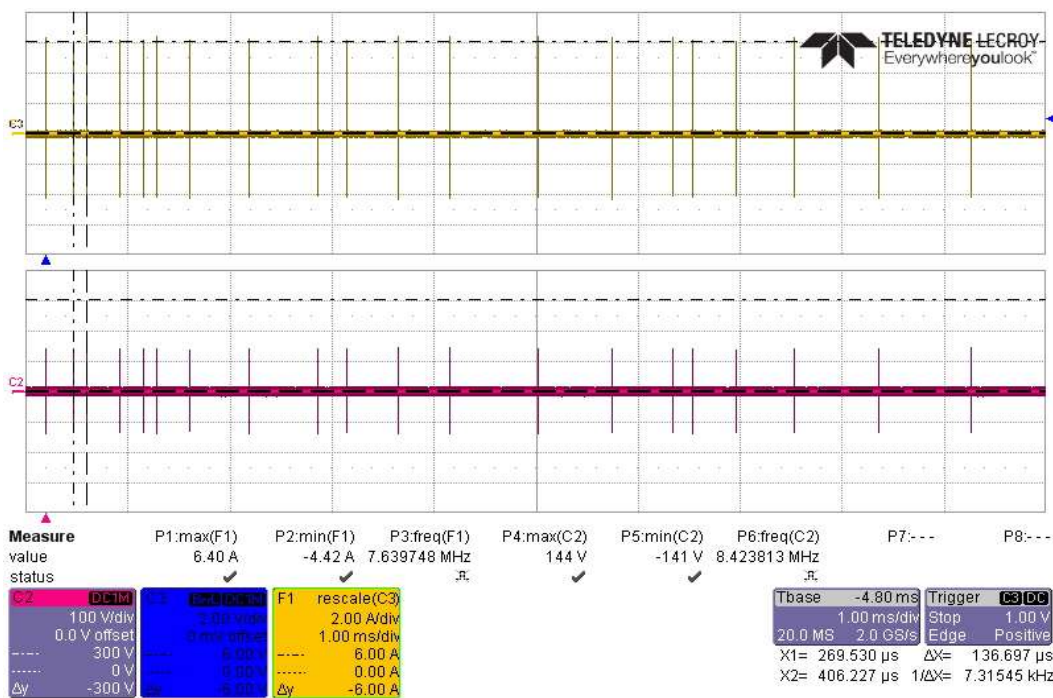

CS117 Current Verification Waveform #3 at 10MHz, 20 Transients at +6A

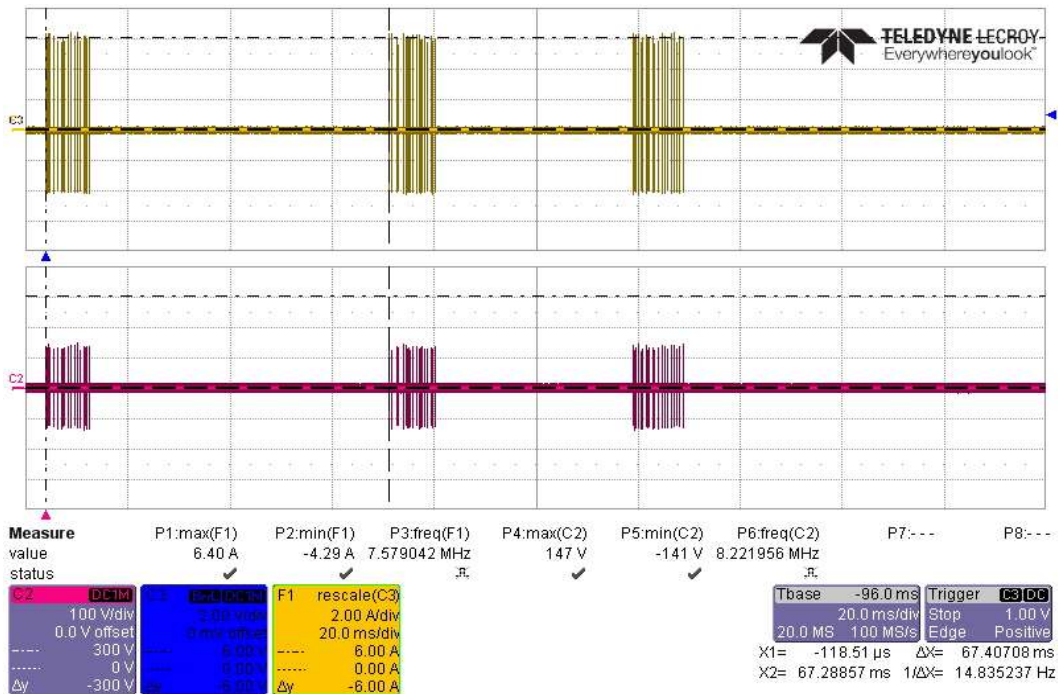

CS117 Current Verification Waveform #3 at 10MHz, 3 Bursts at +6A

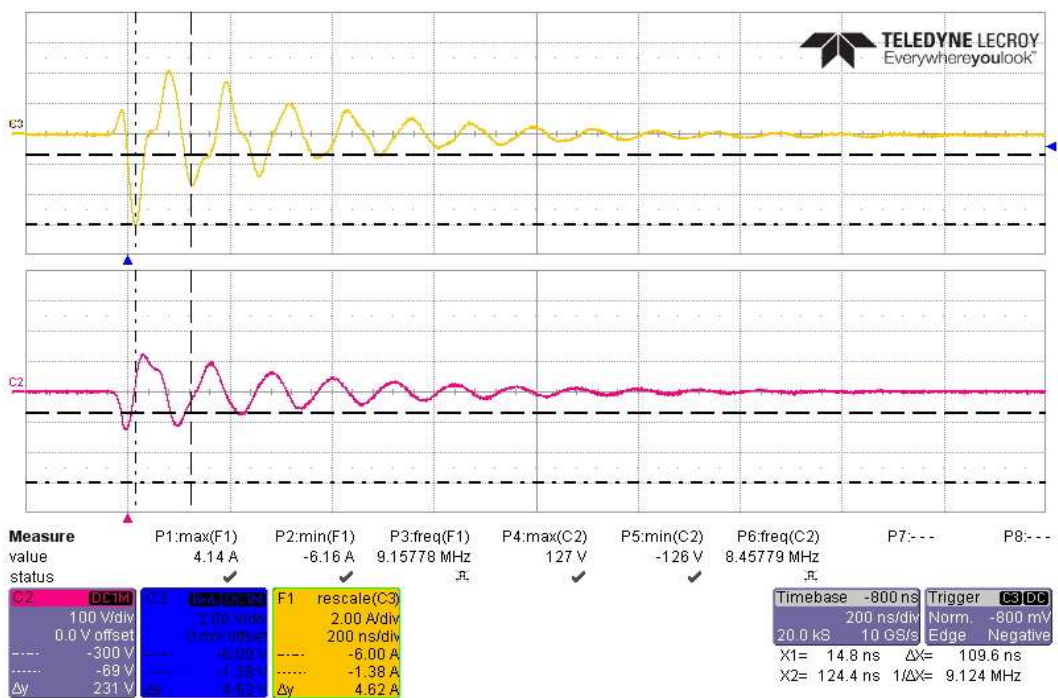

CS117 Current Verification Waveform #3 at 10MHz, First Transient at -6A

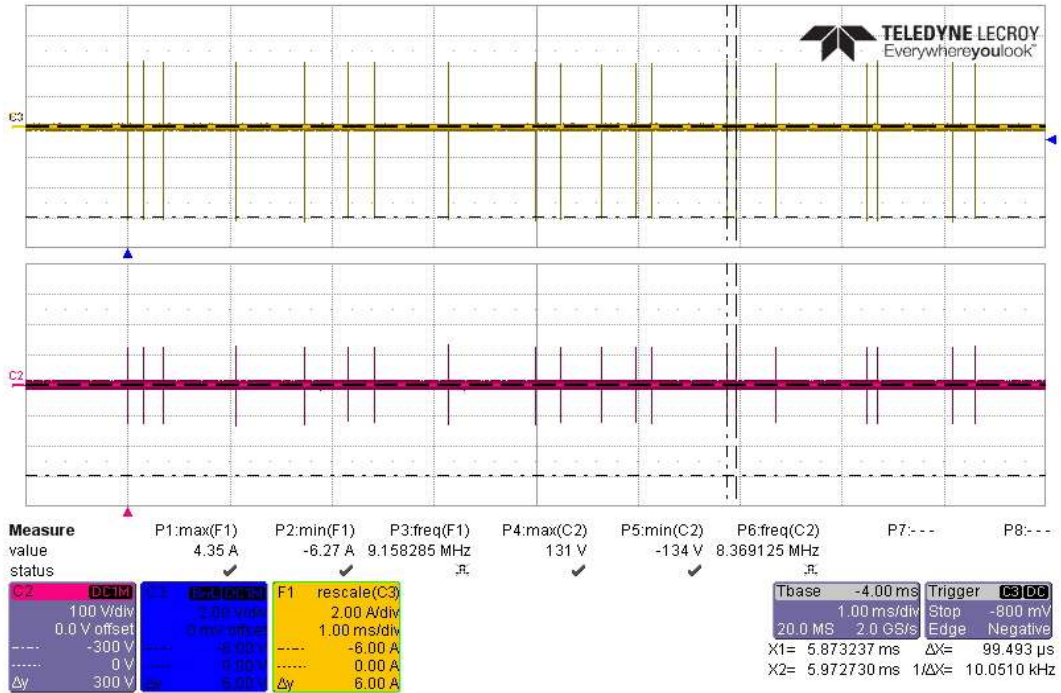

CS117 Current Verification Waveform #3 at 10MHz, 20 Transients at -6A

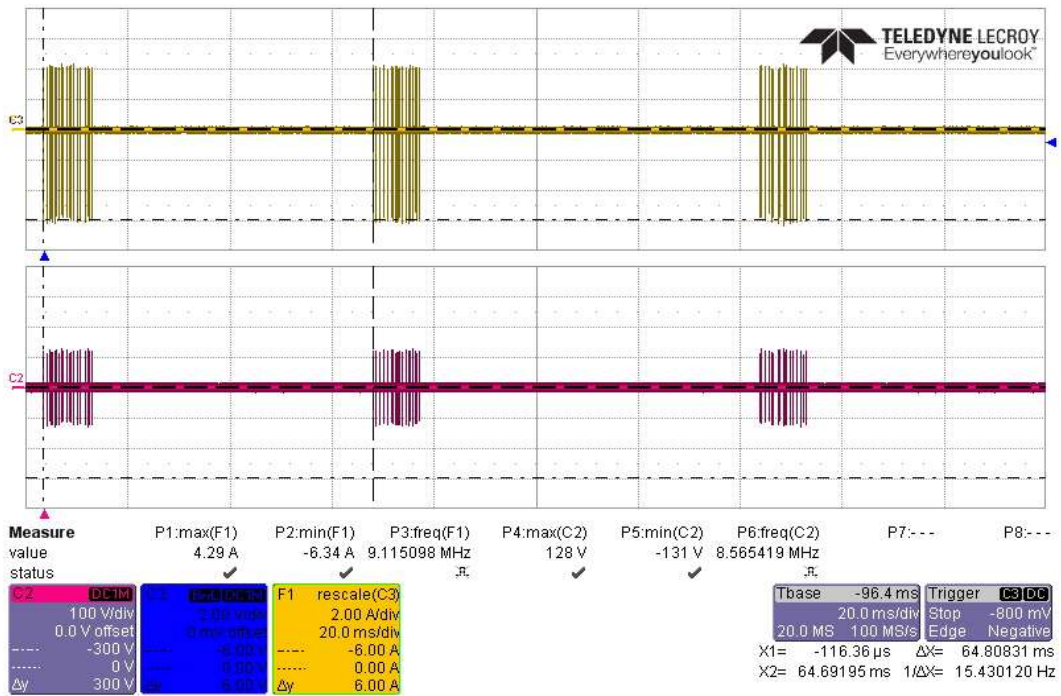

CS117 Current Verification Waveform #3 at 10MHz, 3 Bursts at -6A

5.3.9 CS117 Test Data on Inverter

CUSTOMER:	EG4 Electronics LLC		MJO:	PR183529	
TEST ITEM:	18kPV-12LV		DATE:	6/14/24	
PART NUMBER:	OD00.0000601		UNIT NO:	EMI01 & EMI02	
SPECIFICATION:	MIL-STD-461G		CHAMBER NO:	Workbench 1	
EUT Power Input:			AC 115V/60Hz, DC (Battery Only), & DC (PV Input)		
MIL-STD-461G CS117 Lightning Induced Transient Susceptibility					
Temperature: 85F	Humidity: 42% RH		Barometric Pressure: 981 mBar		
Internal Equipment Levels	Test Level	Test On	Results		Comments
Waveform #1 MS	300VL_60At/150VL_30At	AC Pwr LINE 1	<input type="checkbox"/> Pass	<input type="checkbox"/> Fail	VL reached 1st - WF2 Required
Waveform #1 MS	300VL_60At/150VL_30At	AC Pwr LINE 2	<input type="checkbox"/> Pass	<input type="checkbox"/> Fail	VL reached 1st - WF2 Required
Waveform #1 MS	300VL_120At/150VL_60At	Full AC Power Bundle	<input type="checkbox"/> Pass	<input type="checkbox"/> Fail	VL reached 1st - WF2 Required
Waveform #1 MS	300VL_60At/150VL_30At	DC Battery High Side	<input checked="" type="checkbox"/> Pass	<input type="checkbox"/> Fail	
Waveform #1 MS	300VL_60At/150VL_30At	DC Battery Return Side	<input checked="" type="checkbox"/> Pass	<input type="checkbox"/> Fail	
Waveform #1 MS	300VL_120At/150VL_60At	DC Battery Bundle	<input type="checkbox"/> Pass	<input type="checkbox"/> Fail	VL reached 1st - WF2 Required
Waveform #1 MS	300VL_60At/150VL_30At	PV High Side	<input type="checkbox"/> Pass	<input type="checkbox"/> Fail	VL reached 1st - WF2 Required
Waveform #1 MS	300VL_60At/150VL_30At	PV Return Side	<input type="checkbox"/> Pass	<input type="checkbox"/> Fail	VL reached 1st - WF2 Required
Waveform #1 MS	300VL_120At/150VL_60At	PV Bundle	<input type="checkbox"/> Pass	<input type="checkbox"/> Fail	VL reached 1st - WF2 Required
Waveform #2 MS	300Vt_60AL/150Vt_30AL	AC Pwr LINE 1	<input checked="" type="checkbox"/> Pass	<input type="checkbox"/> Fail	
Waveform #2 MS	300Vt_60AL/150Vt_30AL	AC Pwr LINE 2	<input checked="" type="checkbox"/> Pass	<input type="checkbox"/> Fail	
Waveform #2 MS	300Vt_120AL/150Vt_60AL	Full AC Power Bundle	<input checked="" type="checkbox"/> Pass	<input type="checkbox"/> Fail	
Waveform #2 MS	300Vt_120AL/150Vt_60AL	Battery Bundle	<input checked="" type="checkbox"/> Pass	<input type="checkbox"/> Fail	
Waveform #2 MS	300Vt_120AL/150Vt_60AL	PV Bundle	<input checked="" type="checkbox"/> Pass	<input type="checkbox"/> Fail	
Waveform #2 MS	300Vt_60AL/150Vt_30AL	PV High Side	<input checked="" type="checkbox"/> Pass	<input type="checkbox"/> Fail	
Waveform #2 MS	300Vt_60AL/150Vt_30AL	PV Return Side	<input checked="" type="checkbox"/> Pass	<input type="checkbox"/> Fail	
Waveform #3 MS at 1MHz & 10MHz	600V_24A/300V_12A	AC Pwr LINE 1	<input checked="" type="checkbox"/> Pass	<input type="checkbox"/> Fail	
Waveform #3 MS at 1MHz & 10MHz	600V_24A/300V_12A	AC Pwr LINE 2	<input checked="" type="checkbox"/> Pass	<input type="checkbox"/> Fail	
Waveform #3 MS at 1MHz & 10MHz	600V_48A/300V_24A	Full AC Power Bundle	<input checked="" type="checkbox"/> Pass	<input type="checkbox"/> Fail	
Waveform #3 MS at 1MHz & 10MHz	600V_48A/300V_24A	Battery Bundle	<input checked="" type="checkbox"/> Pass	<input type="checkbox"/> Fail	
Waveform #3 MS at 1MHz & 10MHz	600V_24A/300V_12A	High Side Battery	<input checked="" type="checkbox"/> Pass	<input type="checkbox"/> Fail	
Waveform #3 MS at 1MHz & 10MHz	600V_24A/300V_12A	Return Side Battery	<input checked="" type="checkbox"/> Pass	<input type="checkbox"/> Fail	
Waveform #3 MS at 1MHz & 10MHz	600V_48A/300V_24A	PV Bundle	<input checked="" type="checkbox"/> Pass	<input type="checkbox"/> Fail	
Waveform #3 MS at 1MHz & 10MHz	600V_24A/300V_12A	PV High Side	<input checked="" type="checkbox"/> Pass	<input type="checkbox"/> Fail	
Waveform #3 MS at 1MHz & 10MHz	600V_24A/300V_12A	PV Return Side	<input checked="" type="checkbox"/> Pass	<input type="checkbox"/> Fail	
Waveform #3 MB at 1MHz & 10MHz	360Vt_6AL	AC Pwr LINE 1	<input checked="" type="checkbox"/> Pass	<input type="checkbox"/> Fail	
Waveform #3 MB at 1MHz & 10MHz	360Vt_6AL	AC Pwr LINE 2	<input checked="" type="checkbox"/> Pass	<input type="checkbox"/> Fail	
Waveform #3 MB at 1MHz & 10MHz	360Vt_6AL	Full AC Power Bundle	<input checked="" type="checkbox"/> Pass	<input type="checkbox"/> Fail	
Waveform #3 MB at 1MHz & 10MHz	360Vt_6AL	Battery Bundle	<input checked="" type="checkbox"/> Pass	<input type="checkbox"/> Fail	
Waveform #3 MB at 1MHz & 10MHz	360Vt_6AL	High Side Battery	<input checked="" type="checkbox"/> Pass	<input type="checkbox"/> Fail	
Waveform #3 MB at 1MHz & 10MHz	360Vt_6AL	Return Side Battery	<input checked="" type="checkbox"/> Pass	<input type="checkbox"/> Fail	
Waveform #3 MB at 1MHz & 10MHz	360Vt_6AL	PV Bundle	<input checked="" type="checkbox"/> Pass	<input type="checkbox"/> Fail	
Waveform #3 MB at 1MHz & 10MHz	360Vt_6AL	PV High Side	<input checked="" type="checkbox"/> Pass	<input type="checkbox"/> Fail	
Waveform #3 MB at 1MHz & 10MHz	360Vt_6AL	PV Return Side	<input checked="" type="checkbox"/> Pass	<input type="checkbox"/> Fail	
TECHNICIAN / ENGINEER:	Donald Adams		DATE:	6/26/2024	

CS117 Actual Test Multiple Stroke Current Waveform #1 at 60A

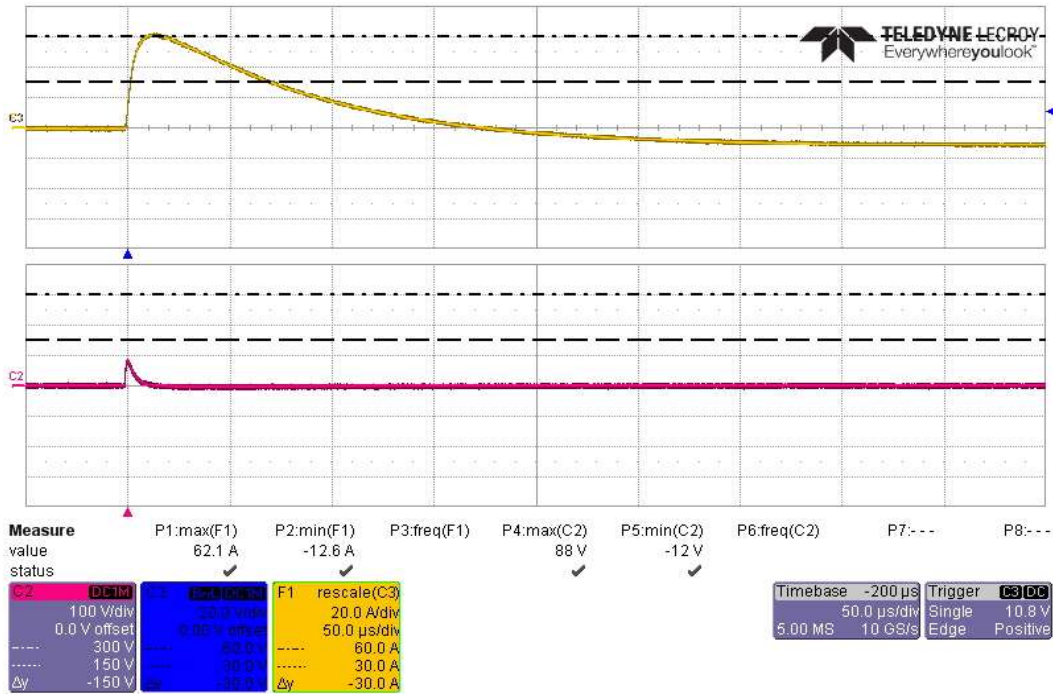

Actual Test CS117 Waveform #1, First Transient +60A, on Battery High Side

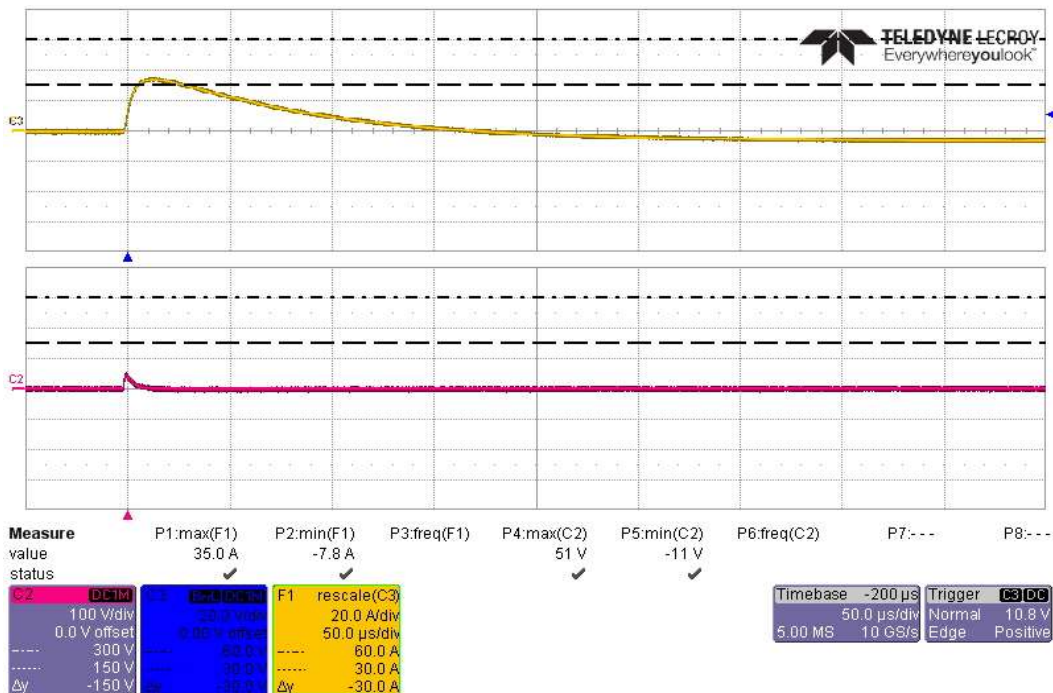

Actual Test CS117 Waveform #1, Subsequent Transient +30A, on Battery High Side

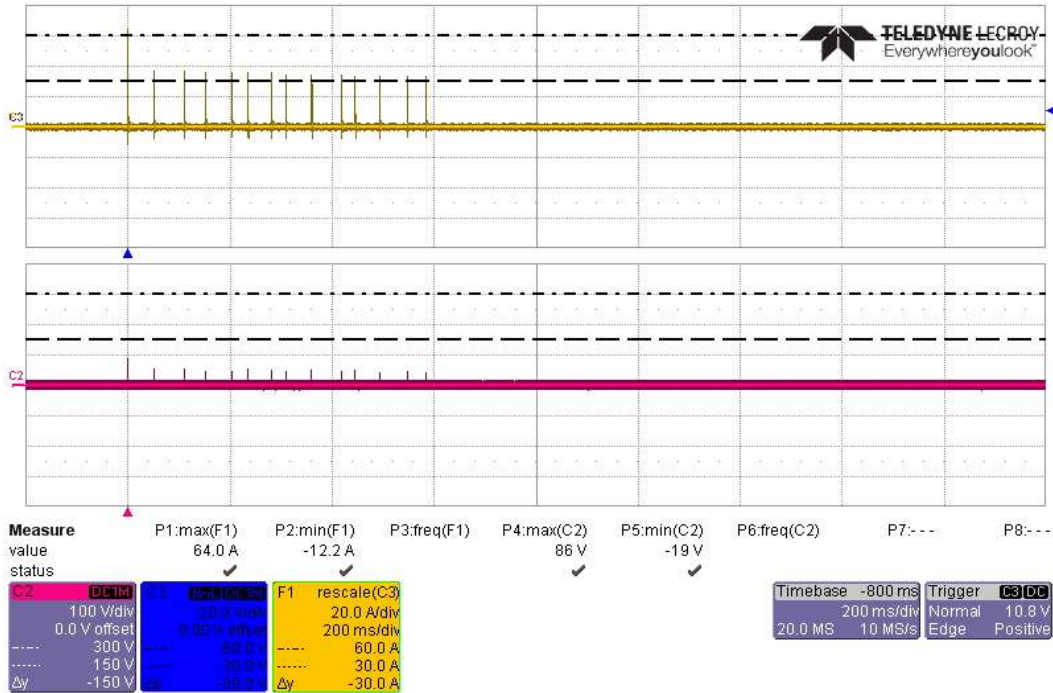

Actual Test CS117 Waveform #1, 14 Transients +60A/30A, on Battery High Side

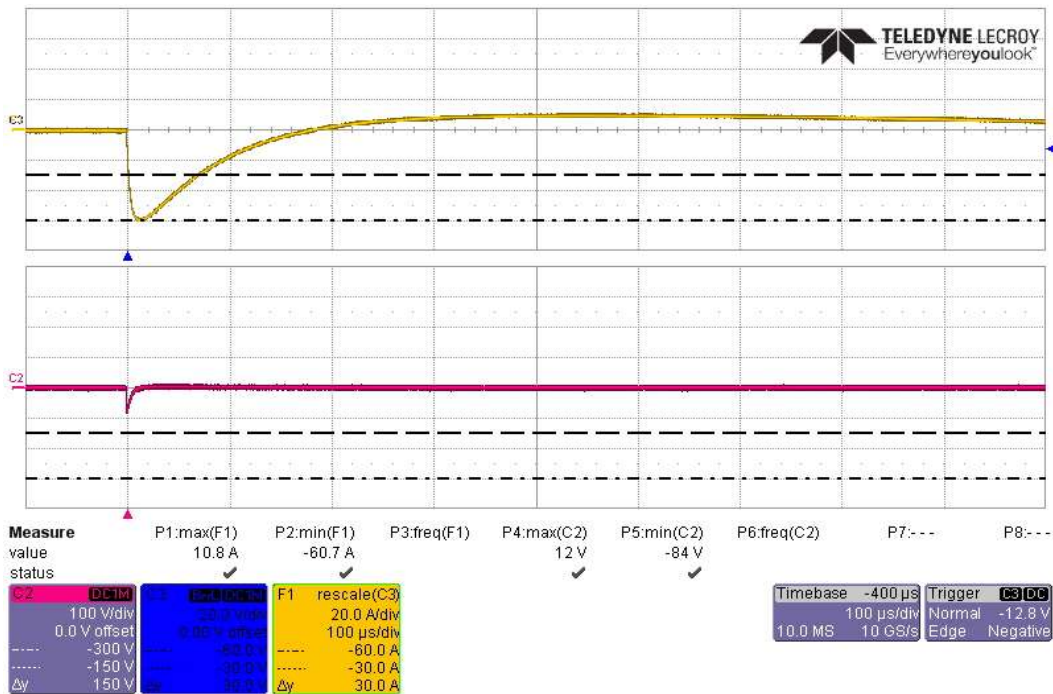

Actual Test CS117 Waveform #1, First Transient -60A, on Battery High Side

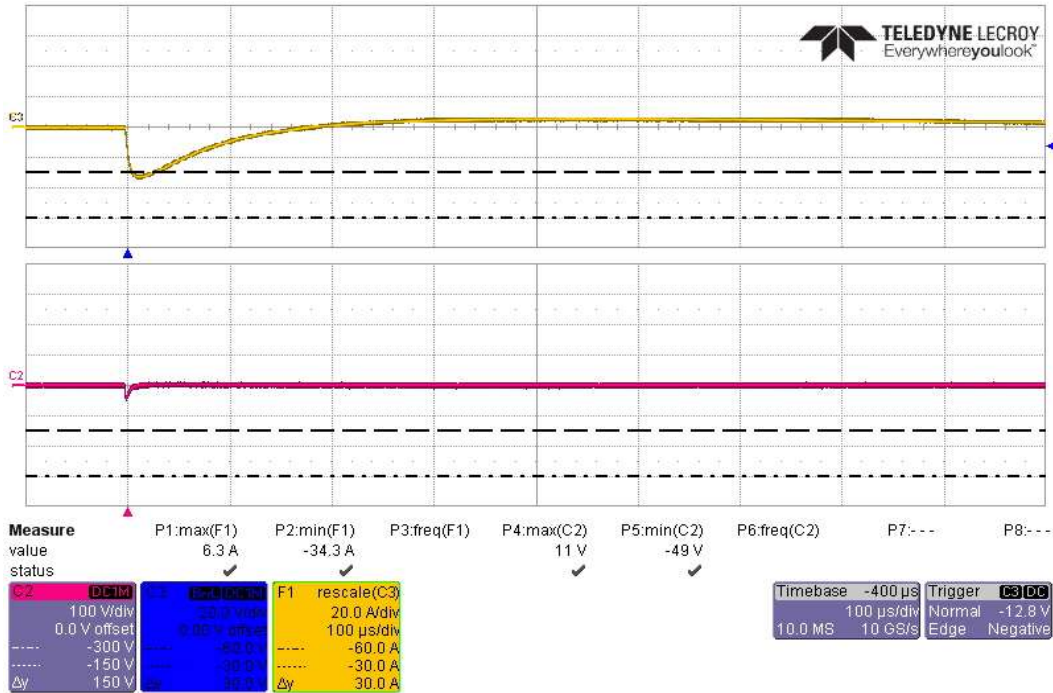

Actual Test CS117 Waveform #1, Subsequent Transient -30A, on Battery High Side

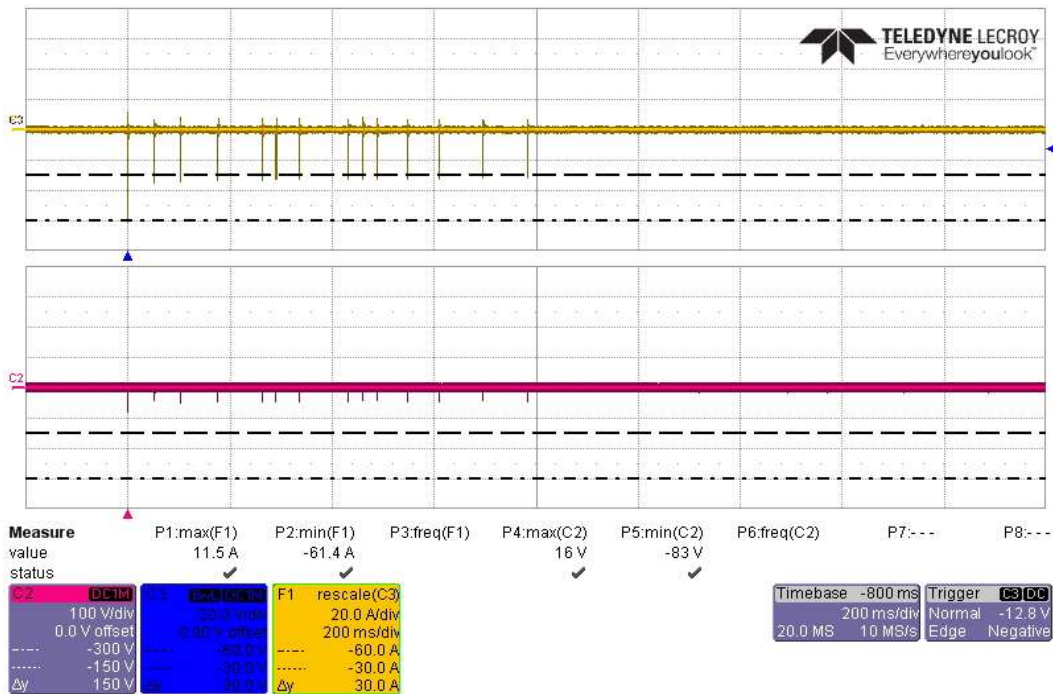

Actual Test CS117 Waveform #1, 14 Transients -60A/30A, on Battery High Side

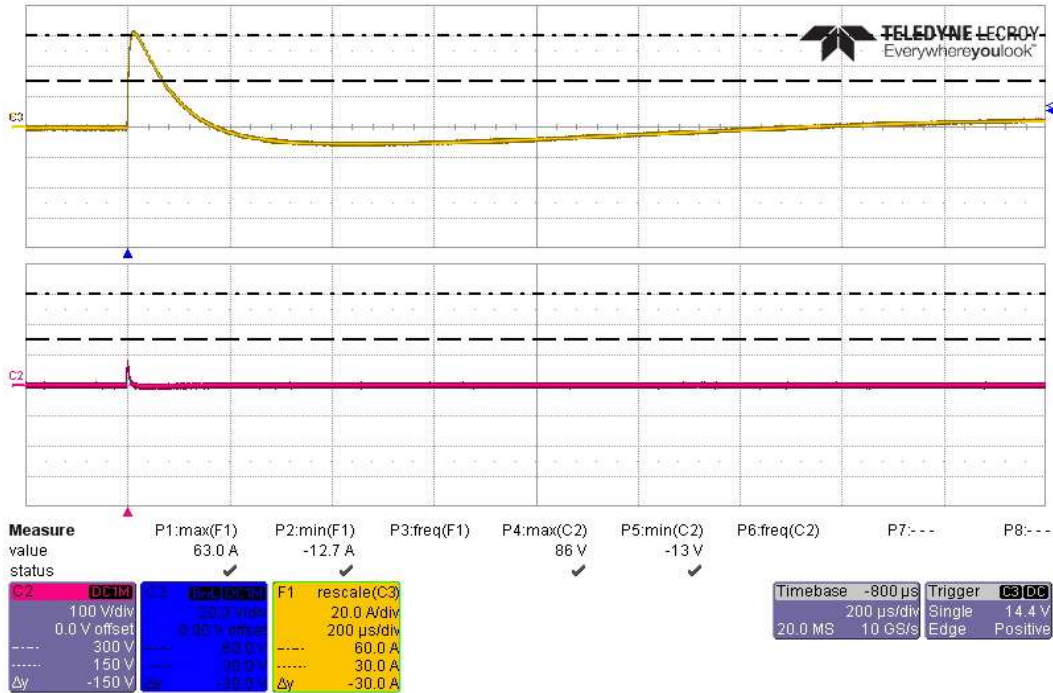

Actual Test CS117 Waveform #1, First Transient +60A, on Battery Return Side

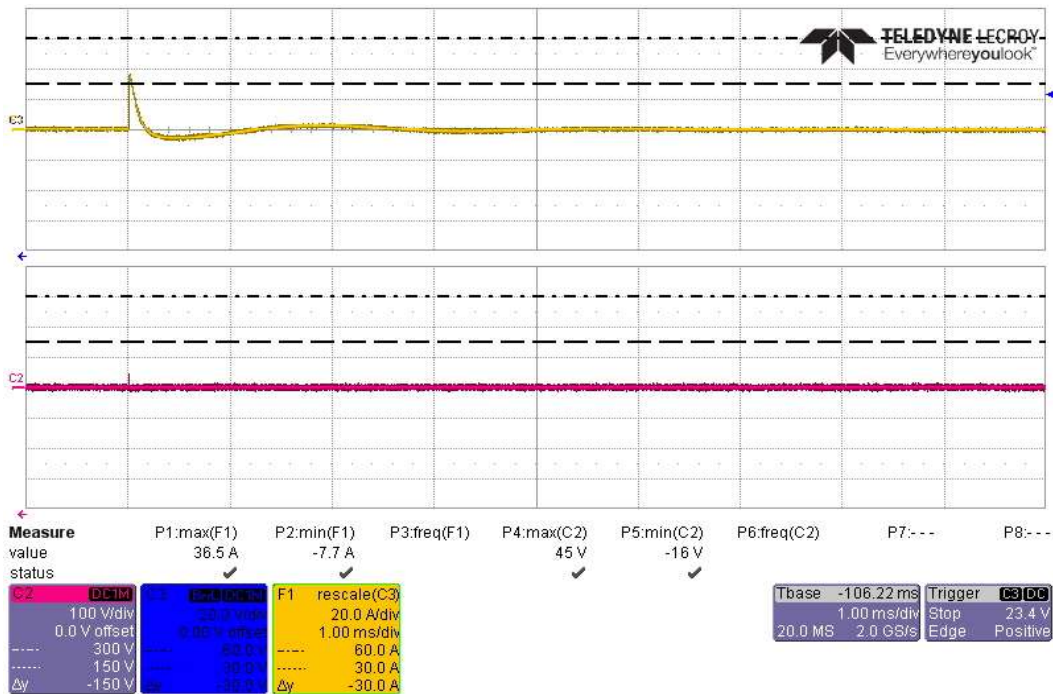

Actual Test CS117 Waveform #1, Subsequent Transient +30A, on Battery Return Side

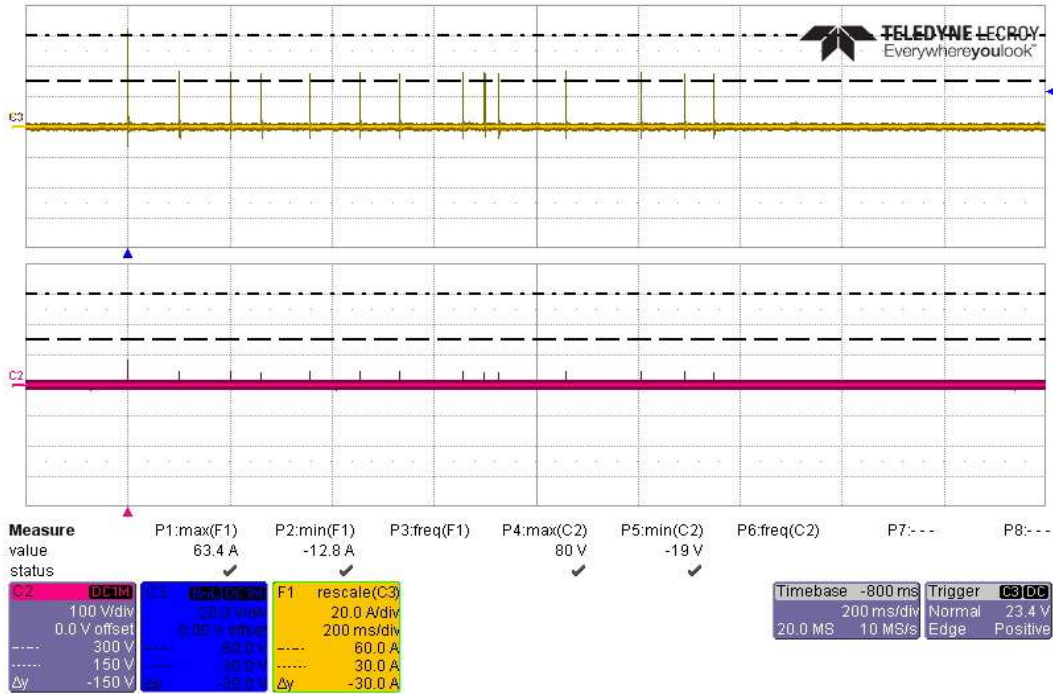

Actual Test CS117 Waveform #1, 14 Transients +60A/30A, on Battery Return Side

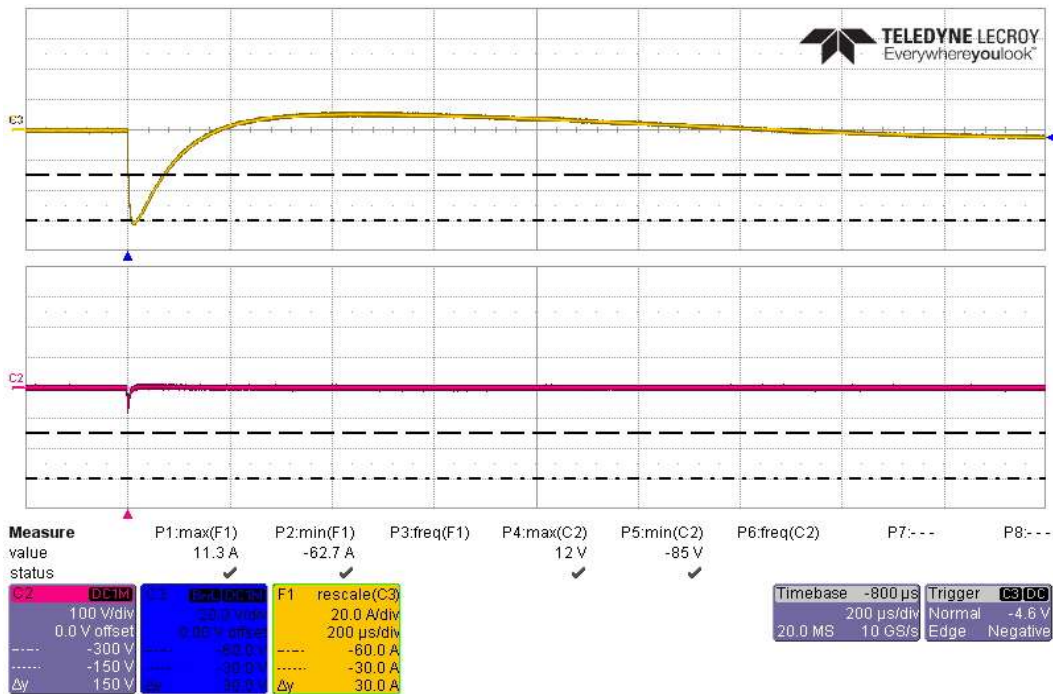

Actual Test CS117 Waveform #1, First Transient -60A, on Battery Return Side

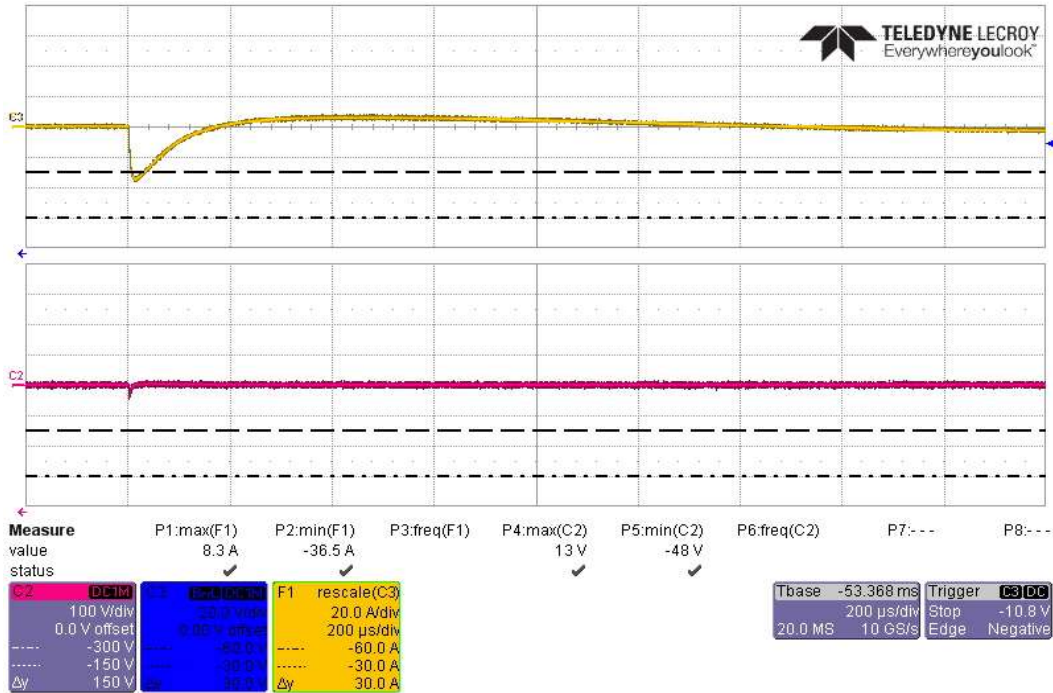

Actual Test CS117 Waveform #1, Subsequent Transient -30A, on Battery Return Side

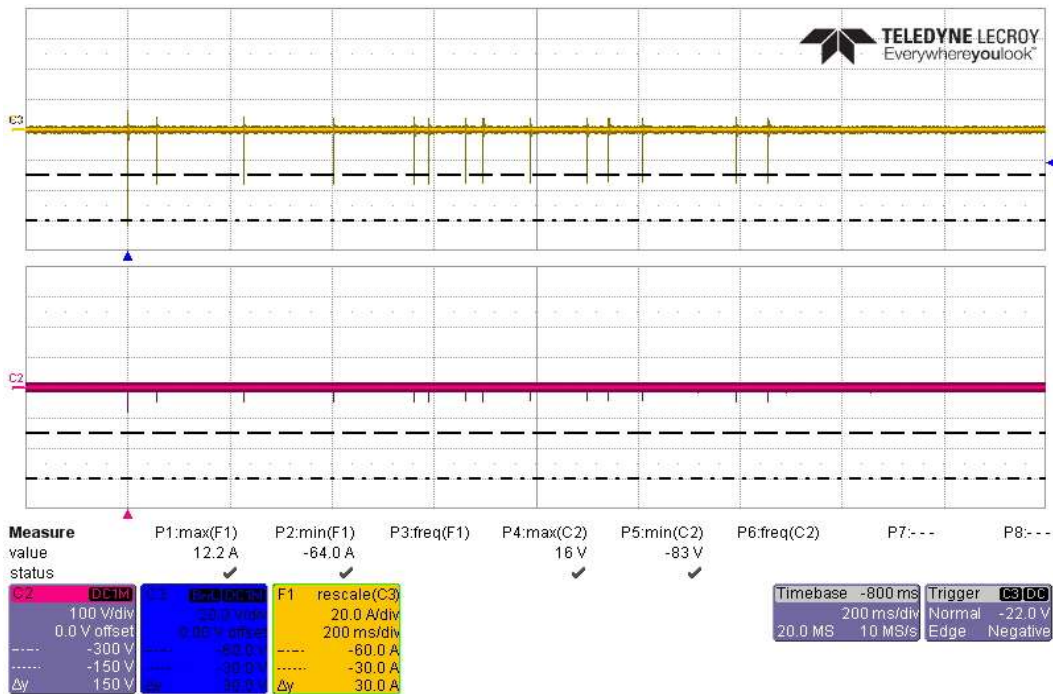

Actual Test CS117 Waveform #1, 14 Transients -60A/30A, on Battery Return Side

CS117 Actual Multiple Stroke Voltage Waveform #2 Test at 300V

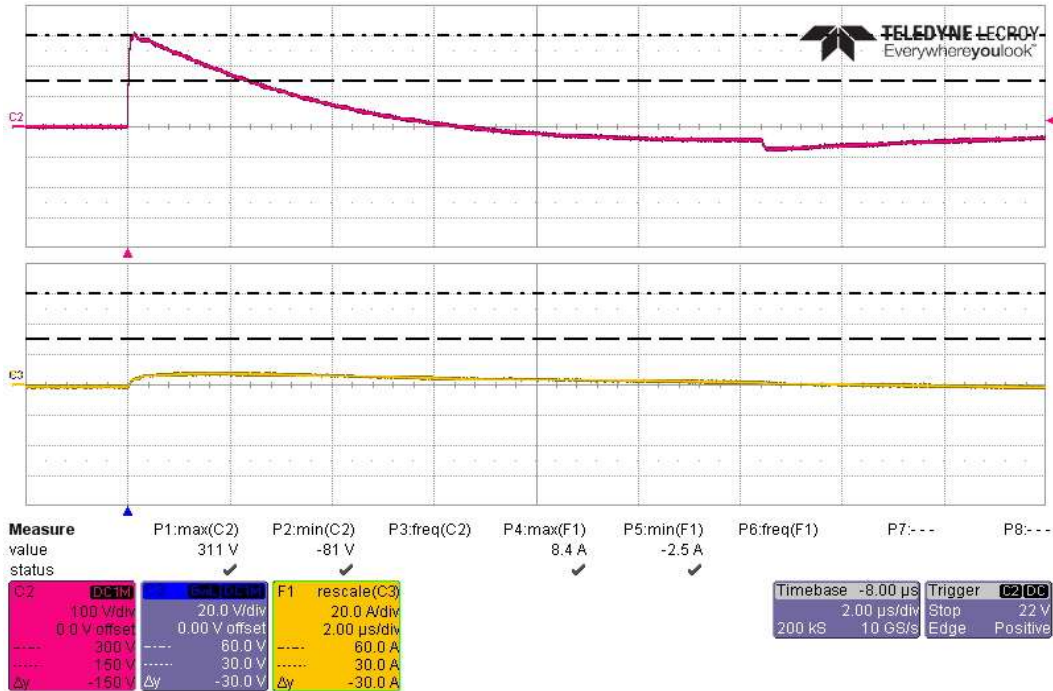

Actual CS117 Voltage Waveform #2 Test, First Transient +300V/60A on AC High Side

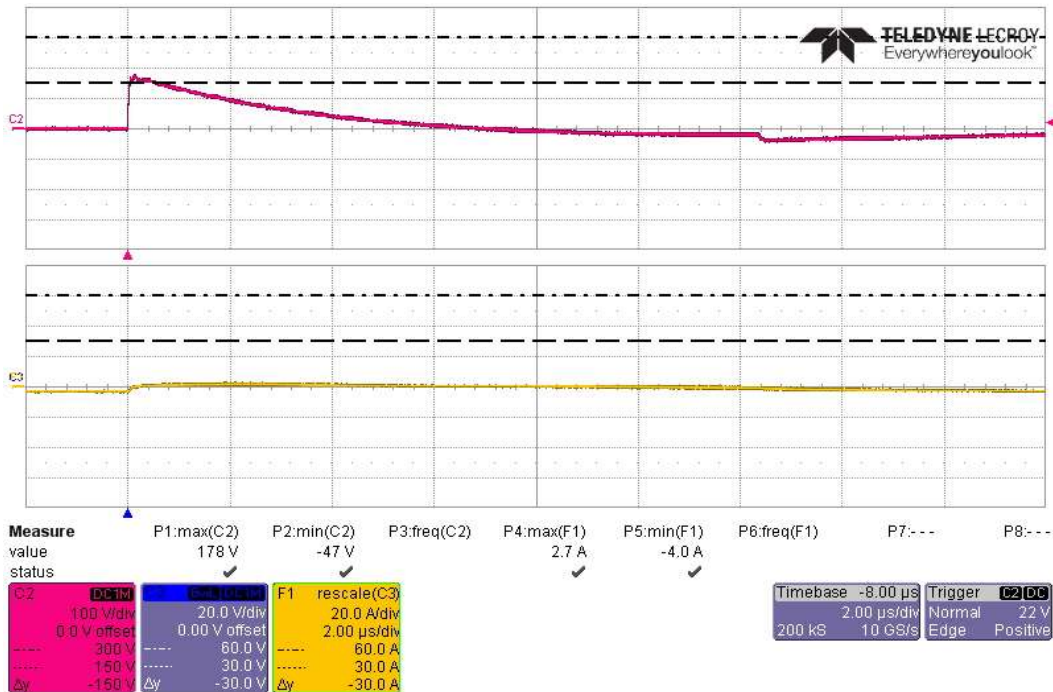

Actual CS117 Voltage Waveform #2 Test, Subsequent Transient +150V/30A on AC High Side

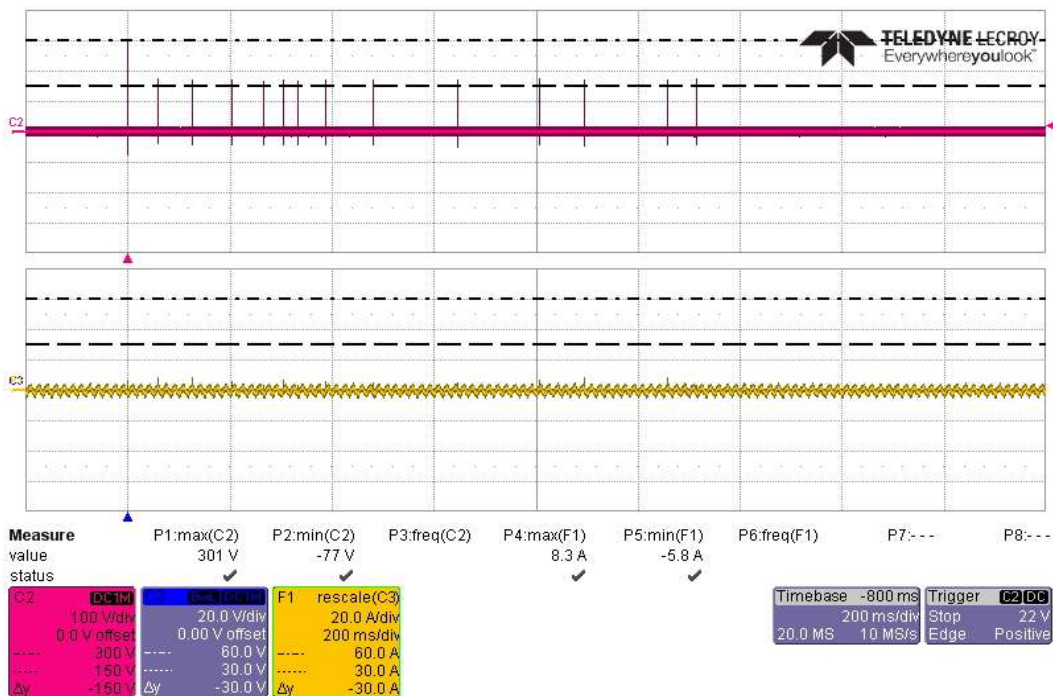

Actual CS117 Voltage Waveform #2 Test, 14 Transient +300V/60A & +150V/30A on AC High Side

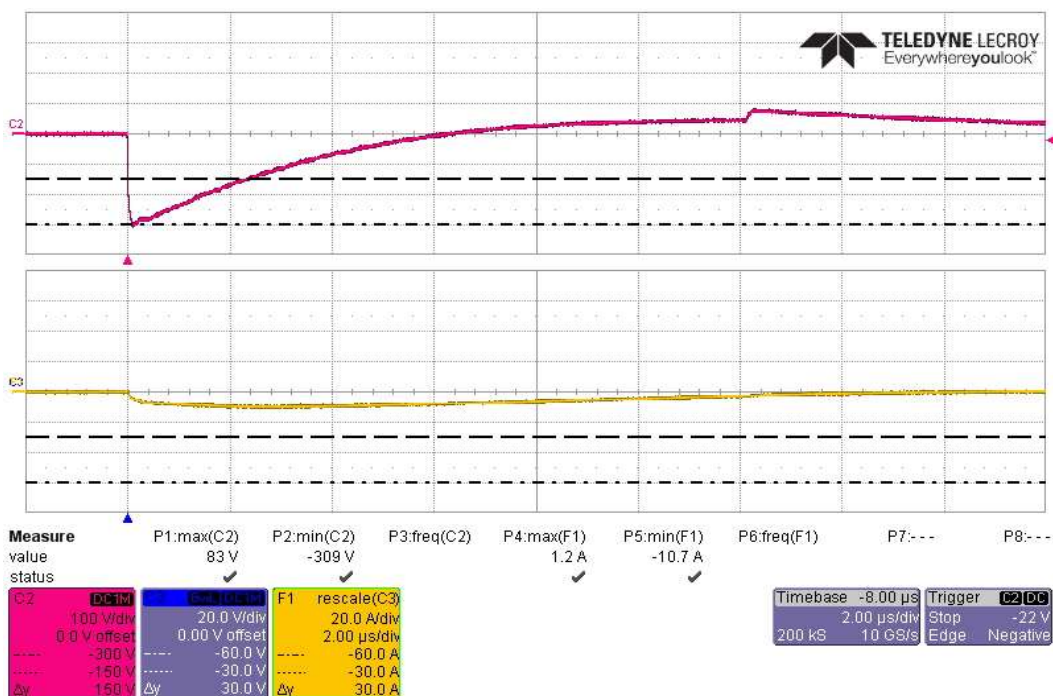

Actual CS117 Voltage Waveform #2 Test, First Transient -300V/60A on AC High Side

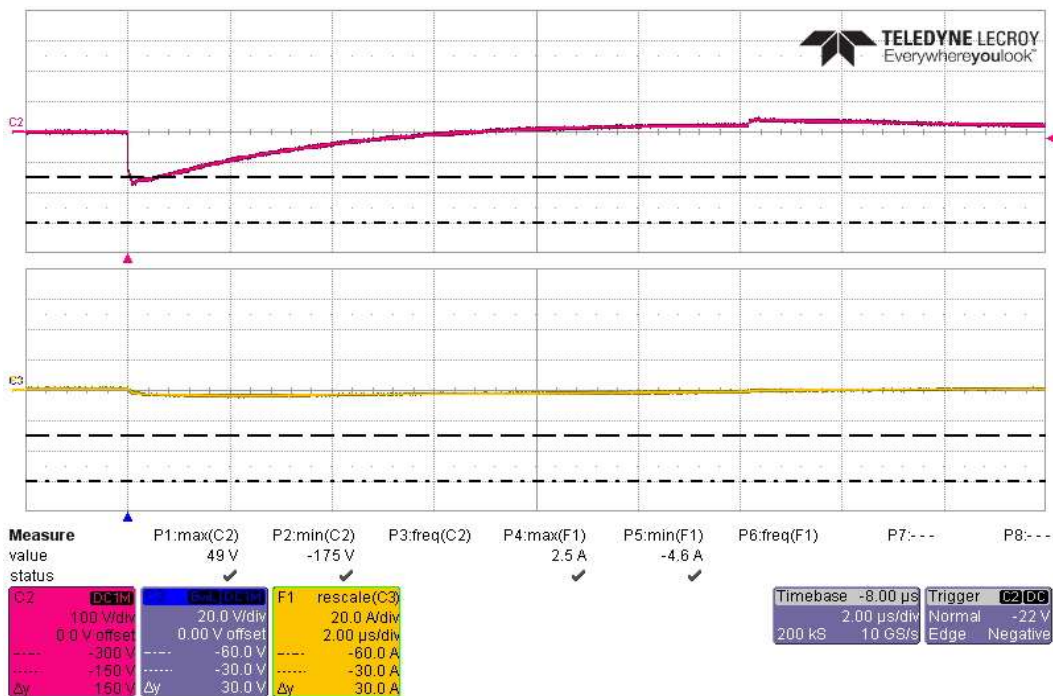

Actual CS117 Voltage Waveform #2 Test, Subsequent Transient -150V/30A on AC High Side

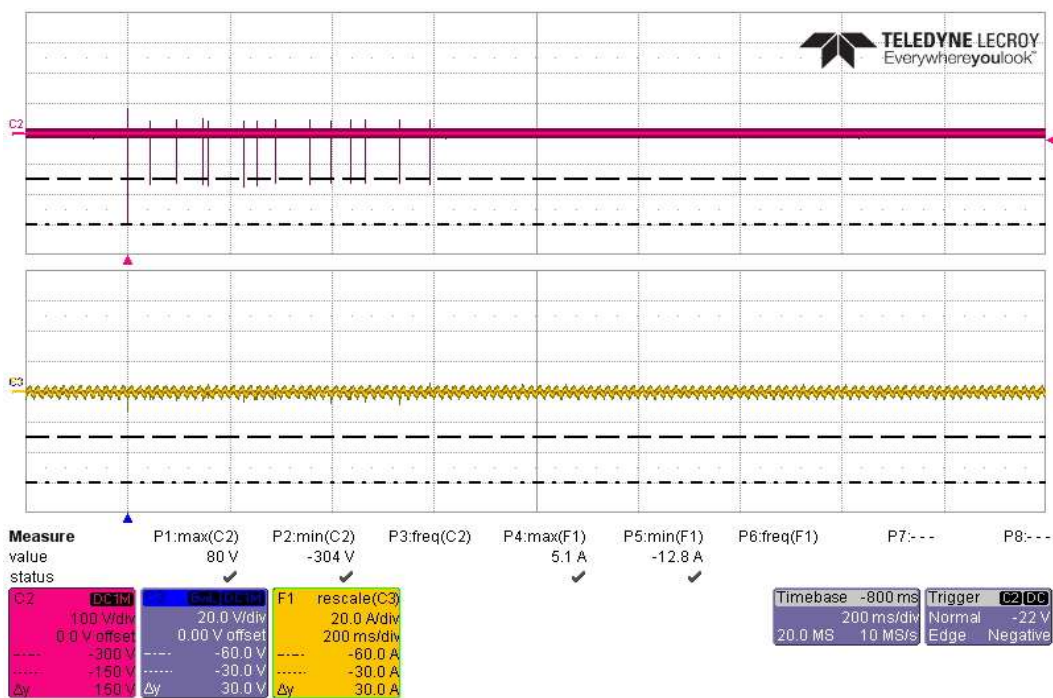

Actual CS117 Voltage Waveform #2 Test, 14 Transient -300V/60A & -150V/30A on AC High Side

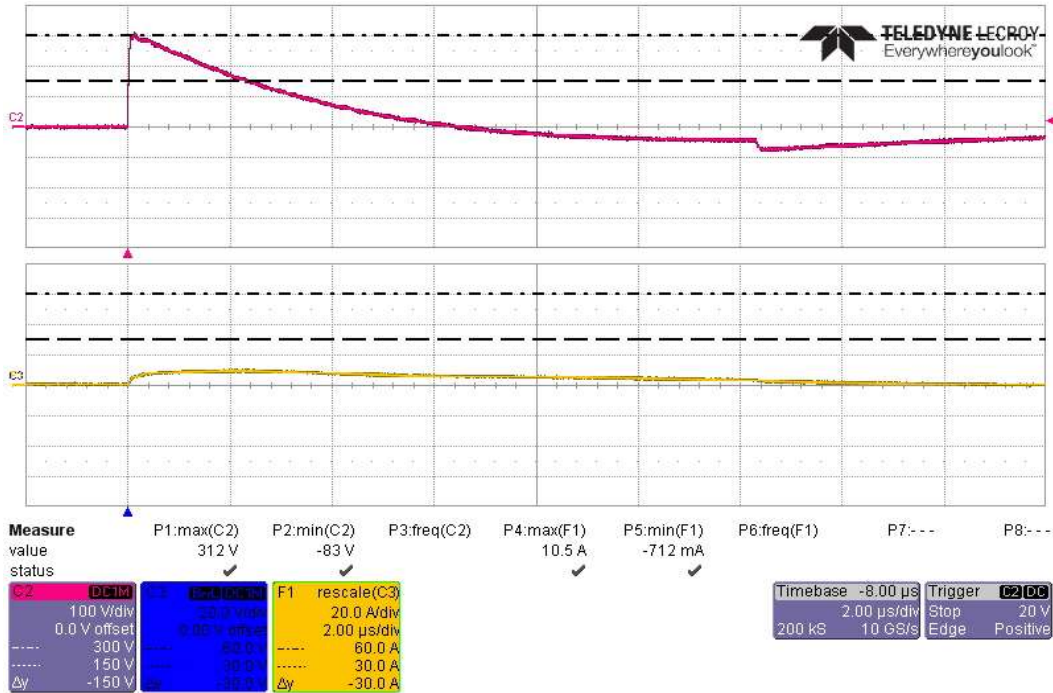

Actual CS117 Voltage Waveform #2 Test, First Transient +300V/60A on AC Return Side

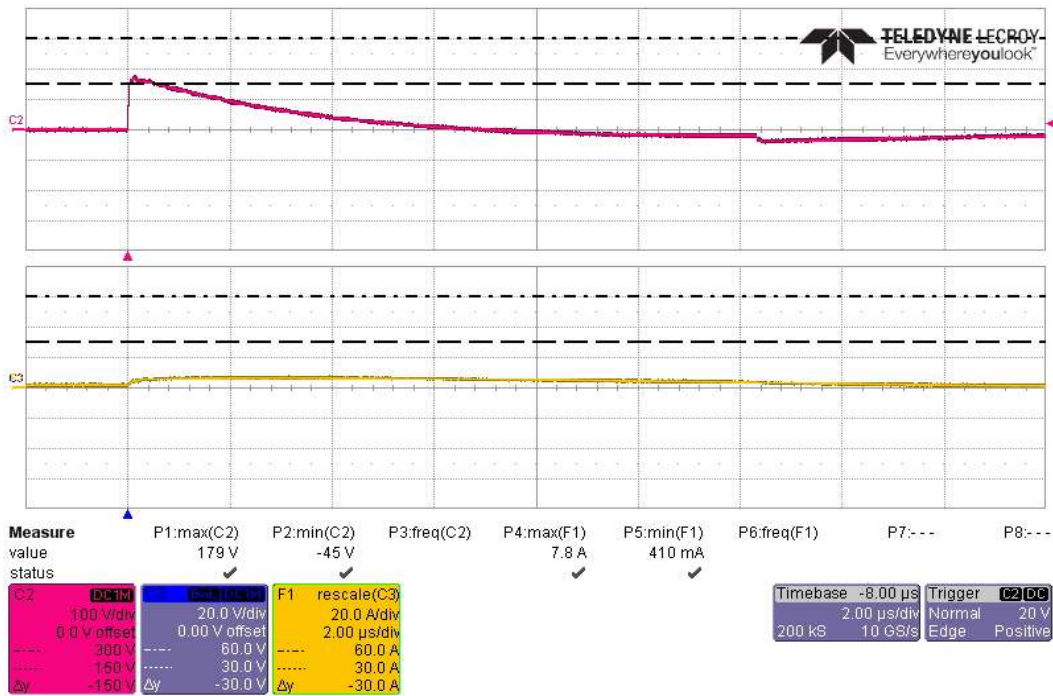

Actual CS117 Voltage Waveform #2 Test, Subsequent Transient +150V/30A on AC Return Side

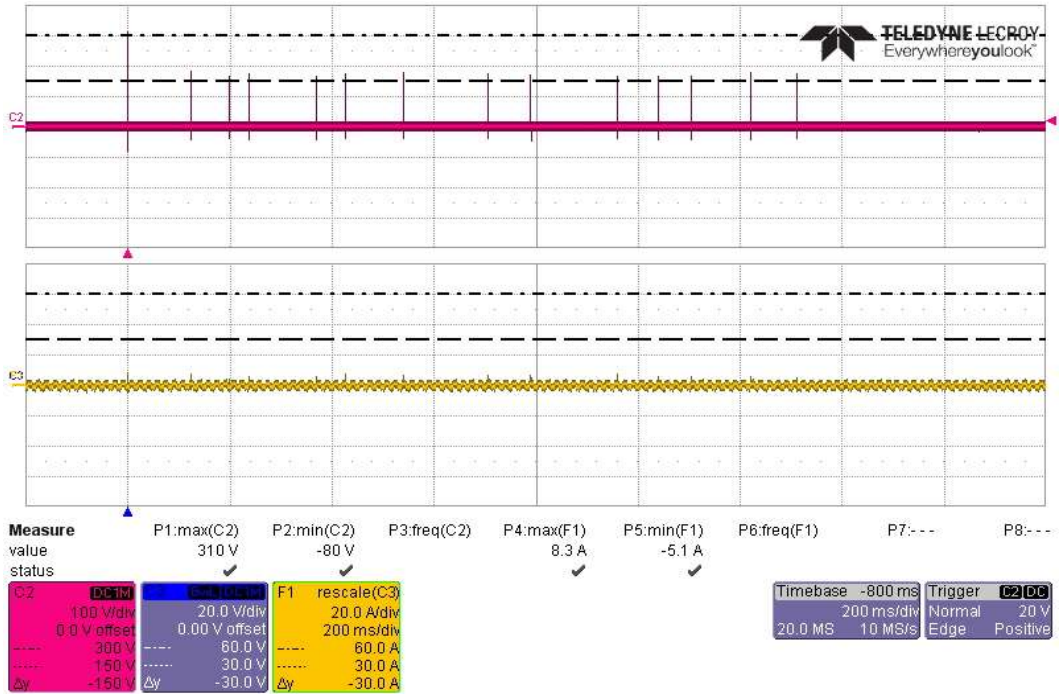

Actual CS117 Voltage Waveform #2 Test, 14 Transient +300V/60A & +150V/30A on AC Return Side

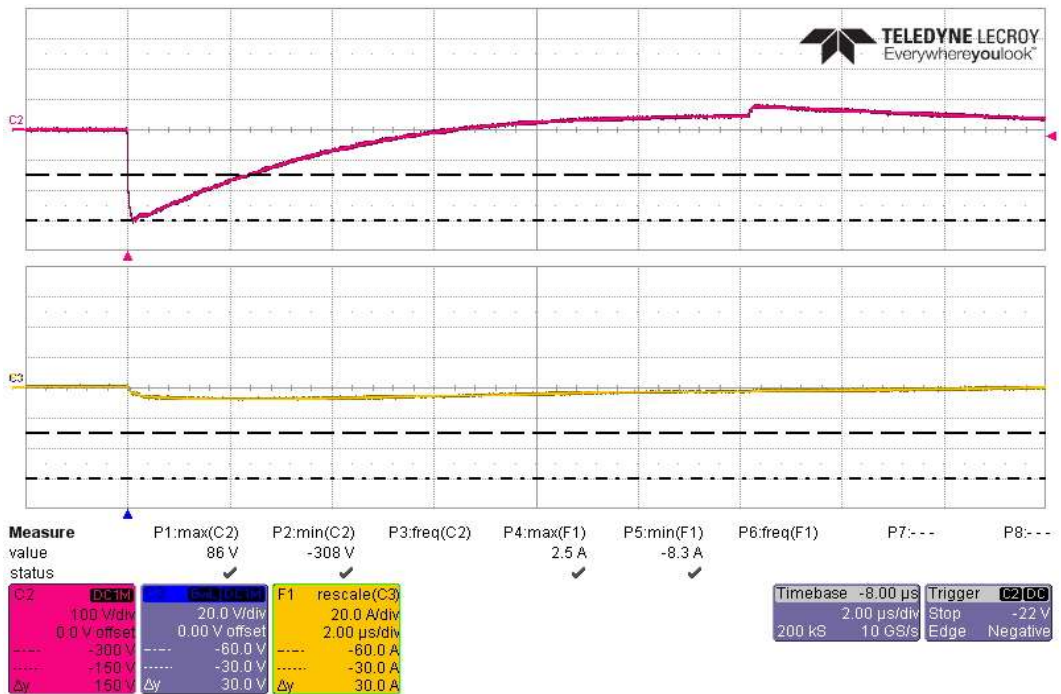

Actual CS117 Voltage Waveform #2 Test, First Transient -300V/60A on AC Return Side

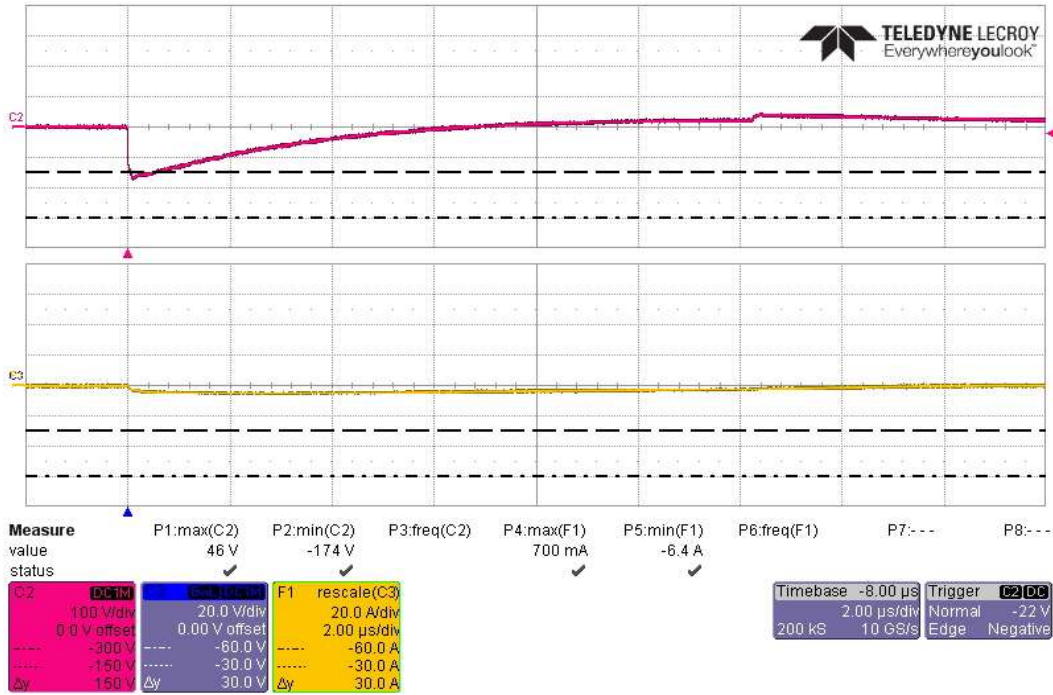

Actual CS117 Voltage Waveform #2 Test, Subsequent Transient -150V/30A on AC Return Side

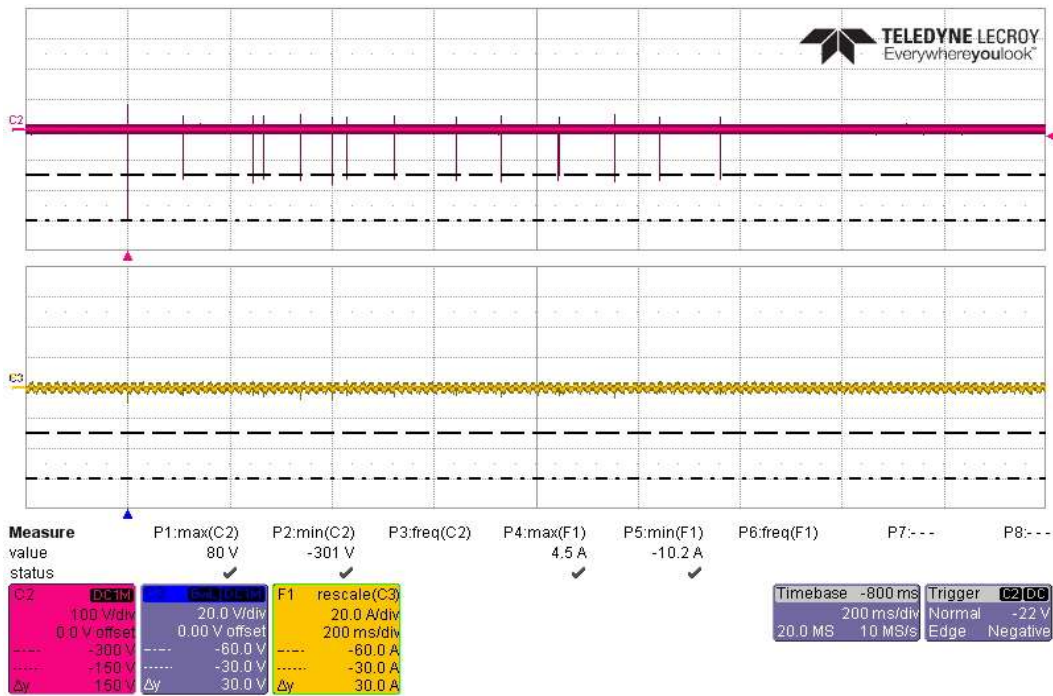

Actual CS117 Voltage Waveform #2 Test, 14 Transient -300V/60A & -150V/30A on AC Return Side

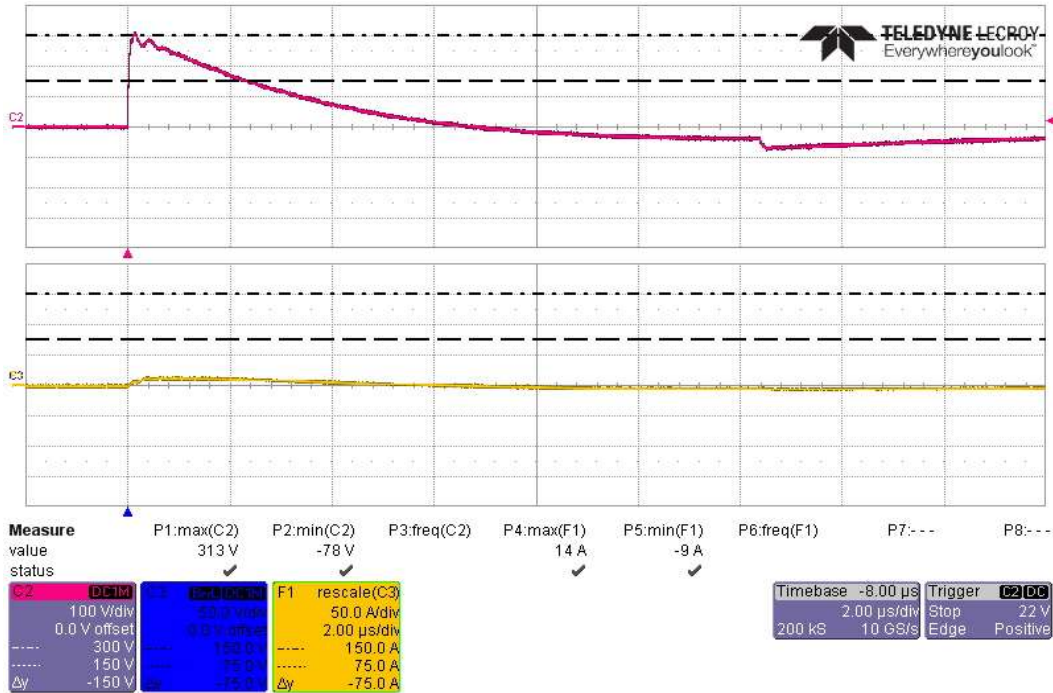

Actual CS117 Voltage Waveform #2 Test, First Transient +300V/120A on Power Lines

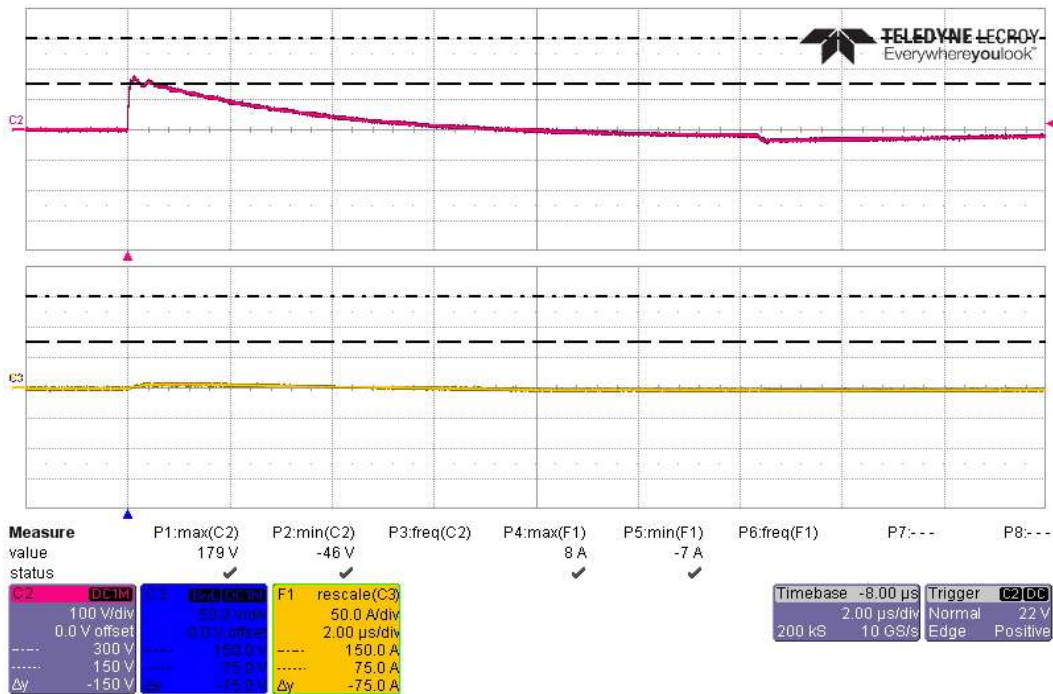

Actual CS117 Voltage Waveform #2 Test, Subsequent Transient +150V/60A on Power Lines

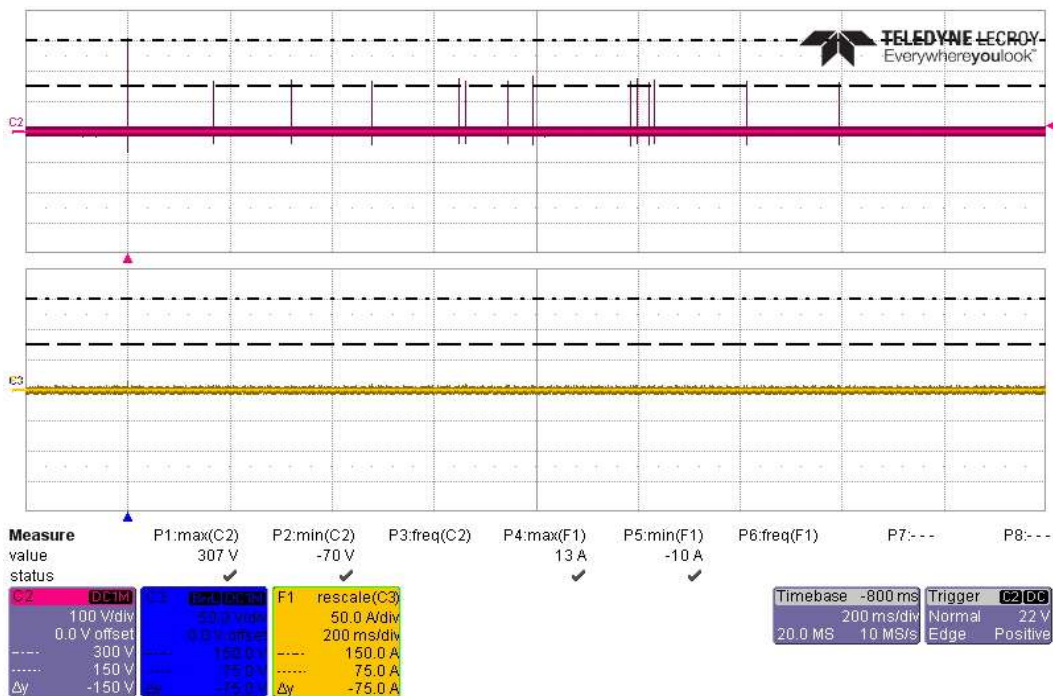

Actual CS117 Voltage Waveform #2 Test, 14 Transient +300V/120A & +150V/60A on Power Lines

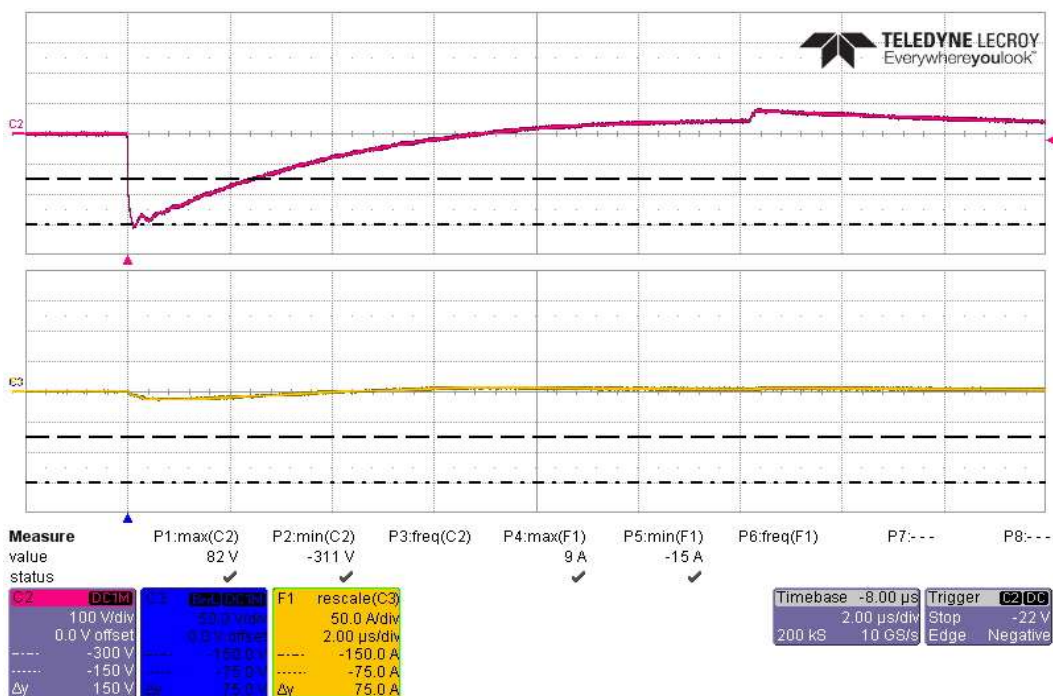

Actual CS117 Voltage Waveform #2 Test, First Transient -300V/120A on Power Lines

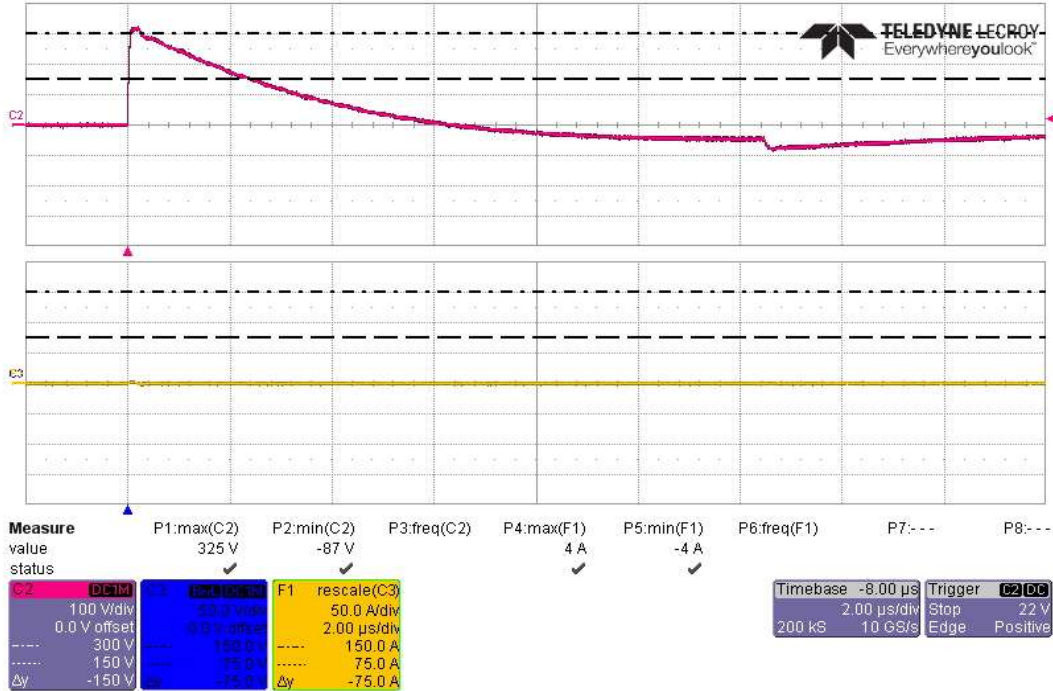

Actual CS117 Voltage Waveform #2 Test, First Transient +300V/120A on Battery Bundle

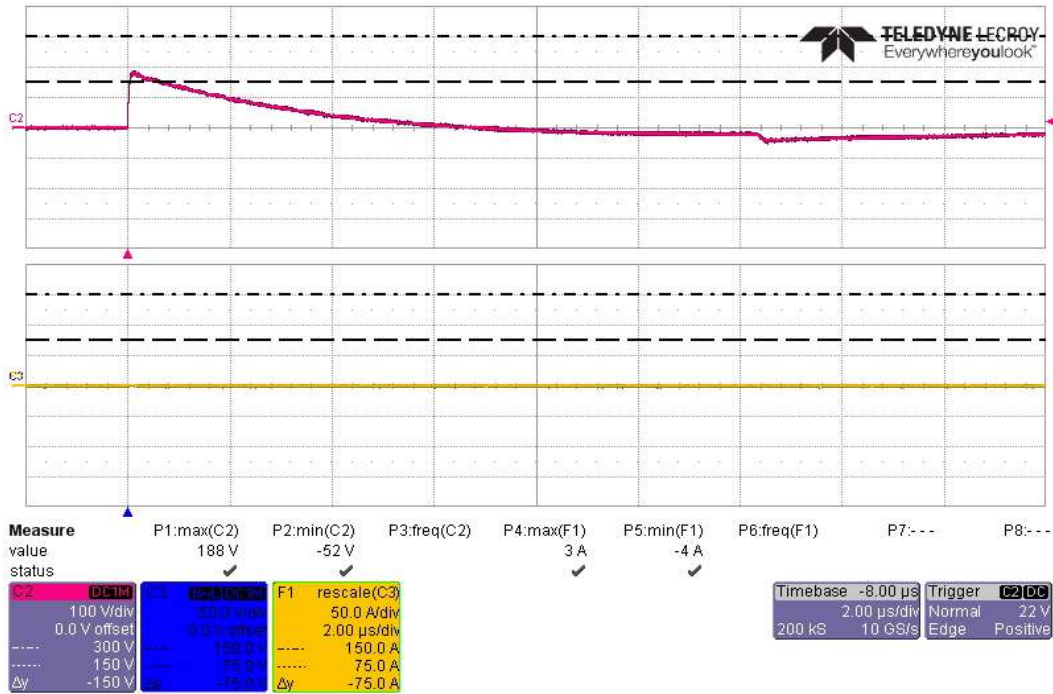

Actual CS117 Voltage Waveform #2 Test, Subsequent Transient +150V/60A on Battery Bundle

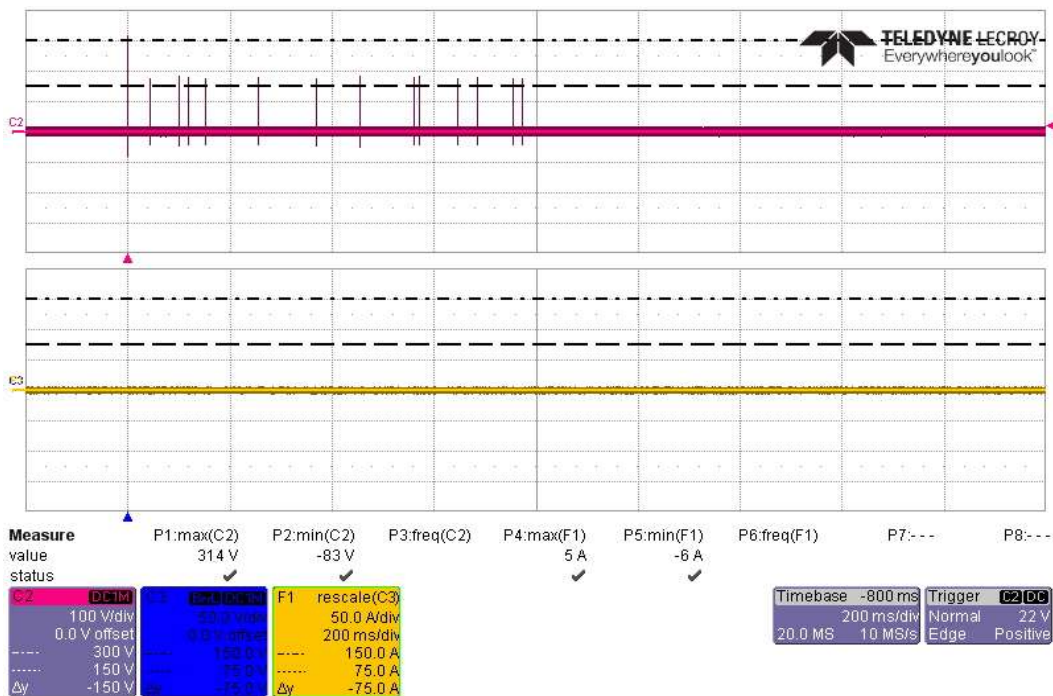

Actual CS117 Voltage Waveform #2 Test, 14 Transient +300V/120A & +150V/60A on Battery Bundle

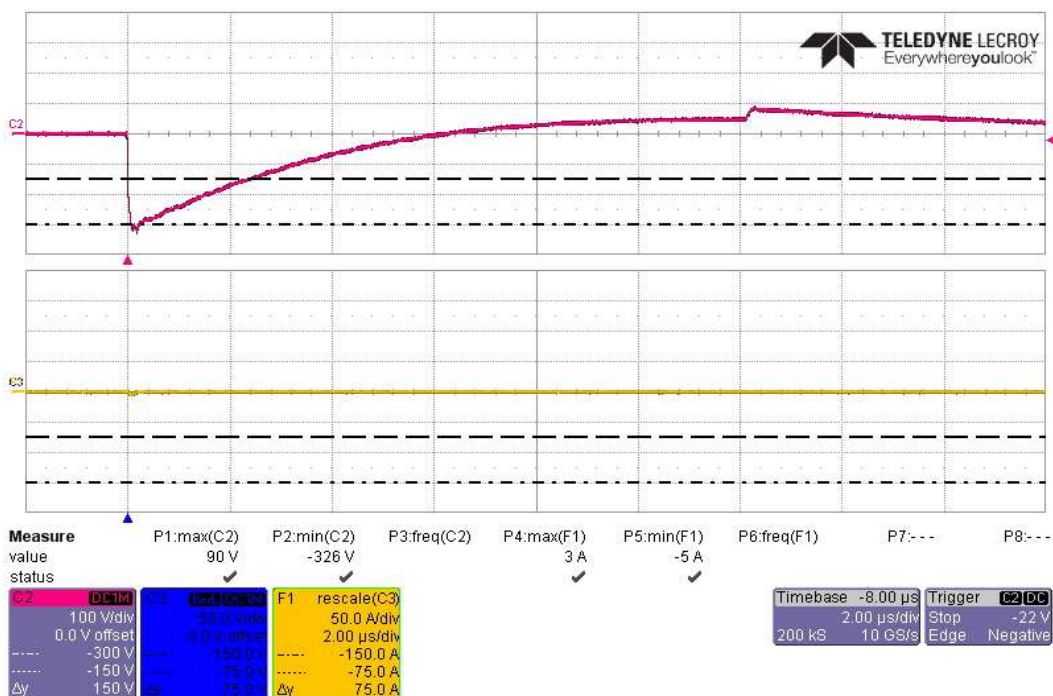

Actual CS117 Voltage Waveform #2 Test, First Transient -300V/120A on Battery Bundle

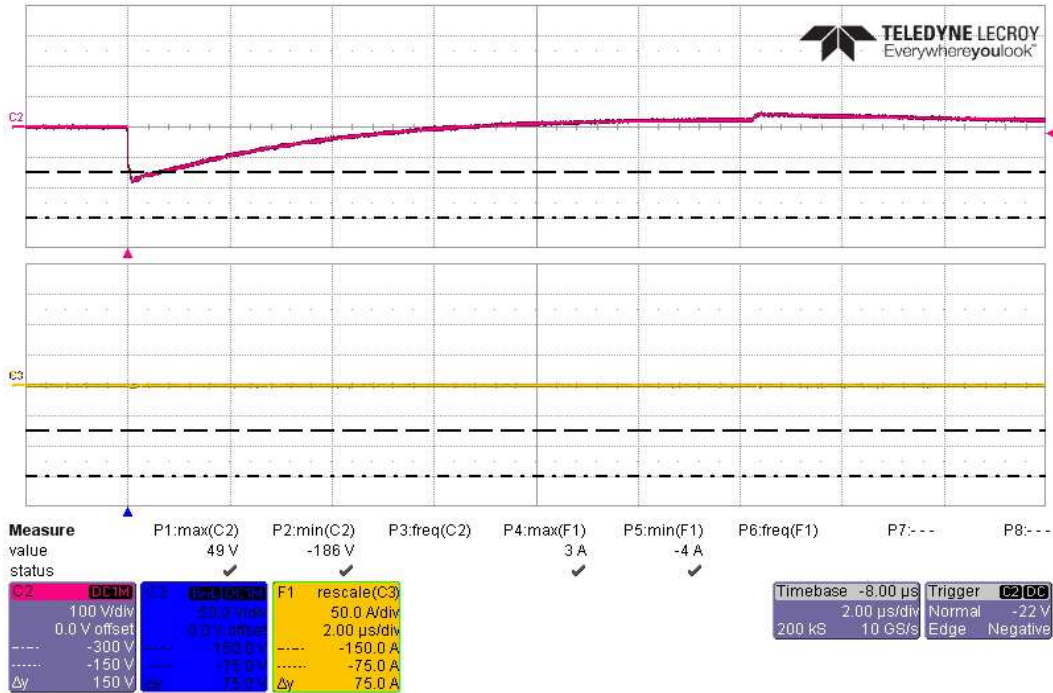

Actual CS117 Voltage Waveform #2 Test, Subsequent Transient -150V/60A on Battery Bundle

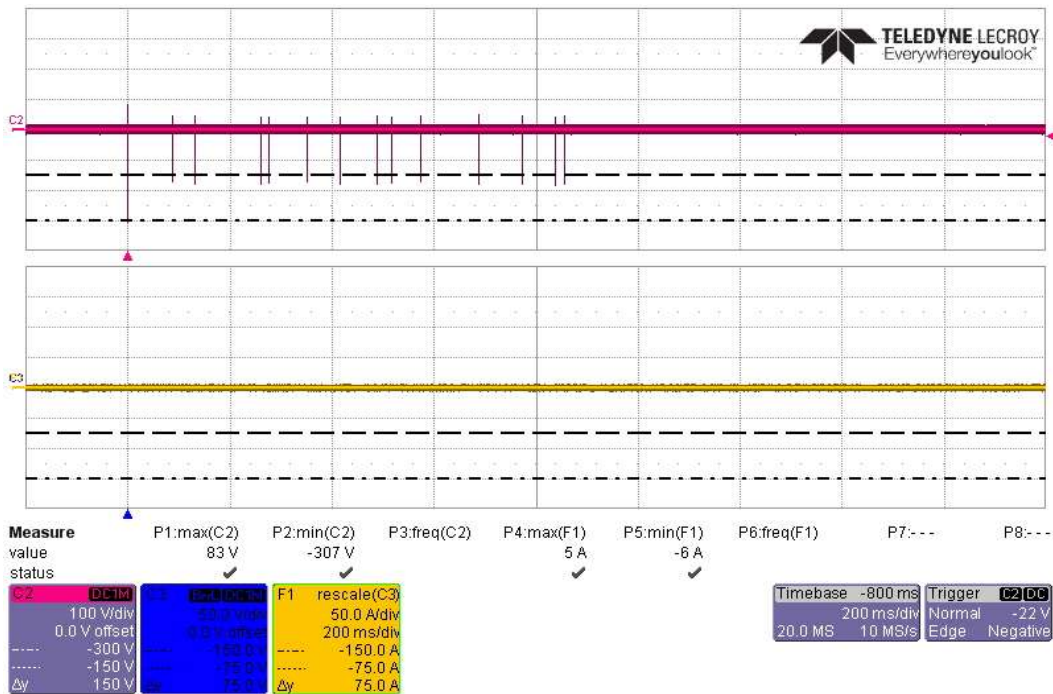

Actual CS117 Voltage Waveform #2 Test, 14 Transient -300V/120A & -150V/60A on Battery Bundle

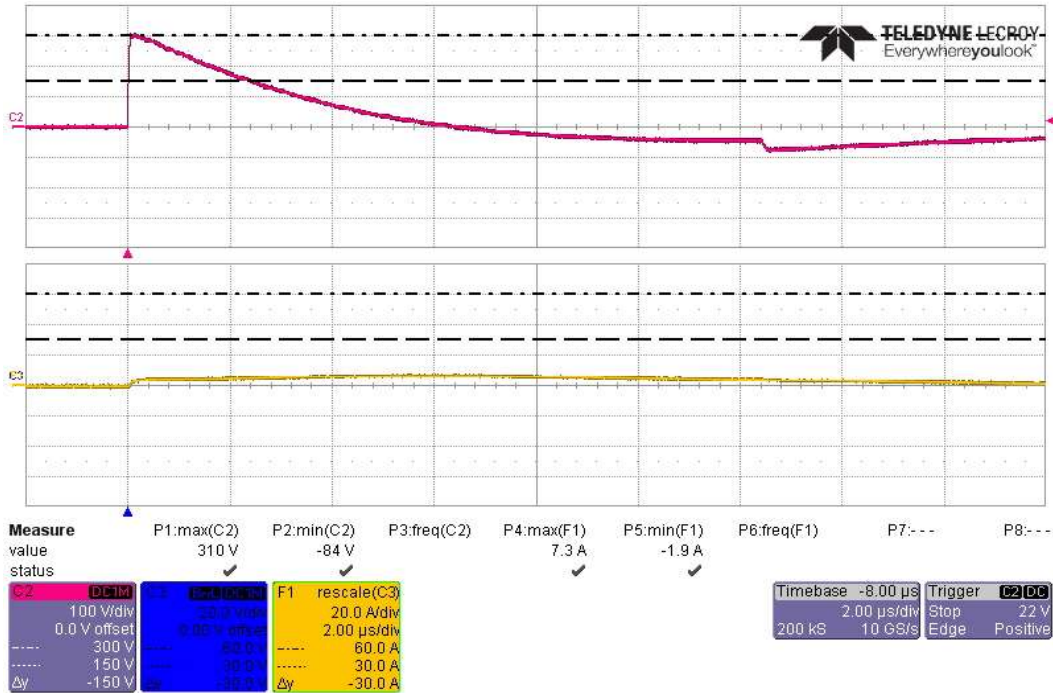

Actual CS117 Voltage Waveform #2 Test, First Transient +300V/60A on PV High Side

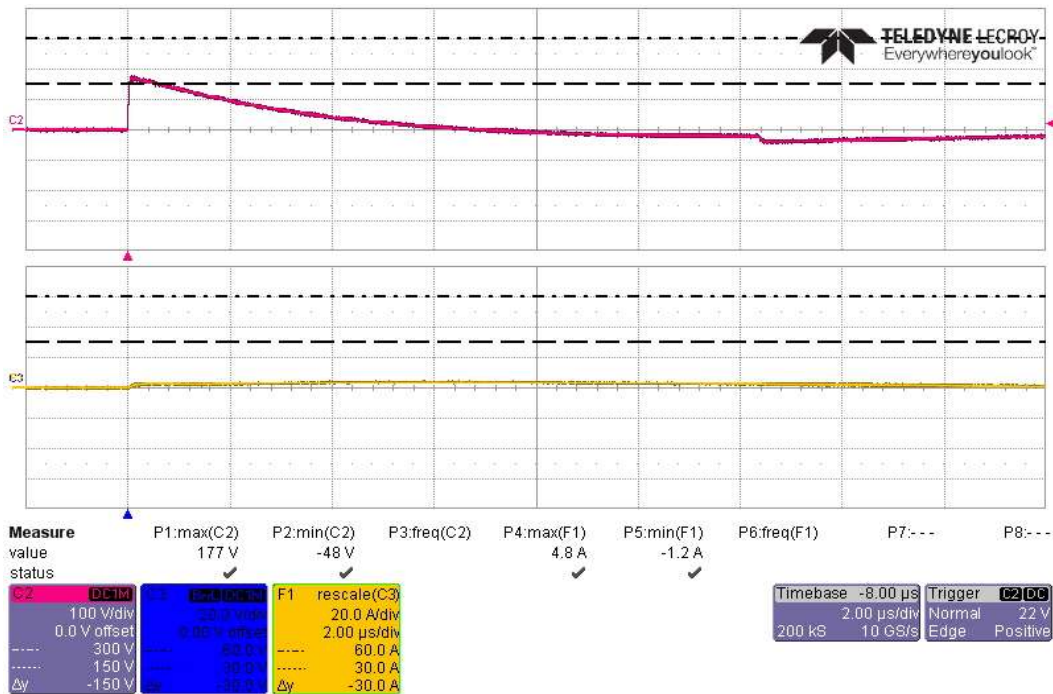

Actual CS117 Voltage Waveform #2 Test, Subsequent Transient +150V/30A on PV High Side

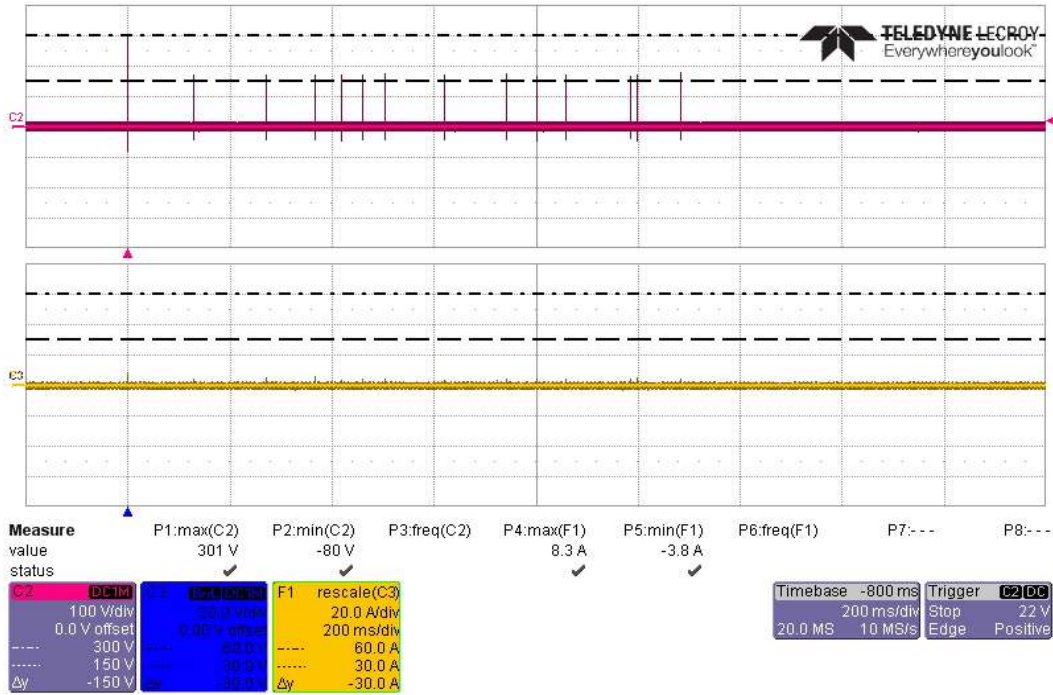

Actual CS117 Voltage Waveform #2 Test, 14 Transient +300V/60A & +150V/30A on PV High Side

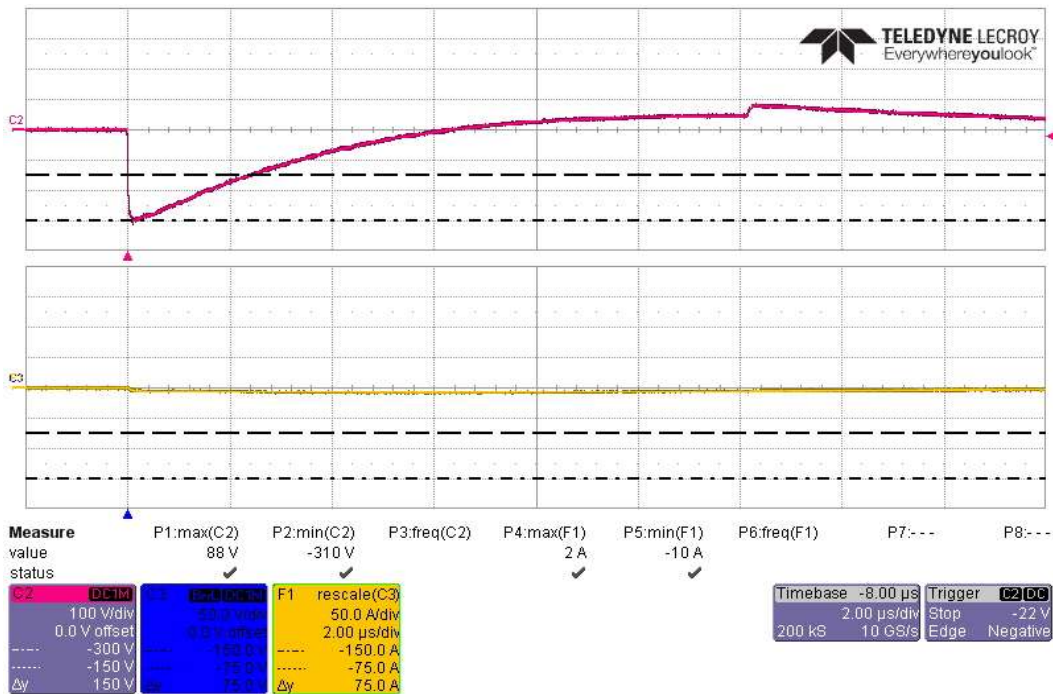

Actual CS117 Voltage Waveform #2 Test, First Transient -300V/60A on PV High Side

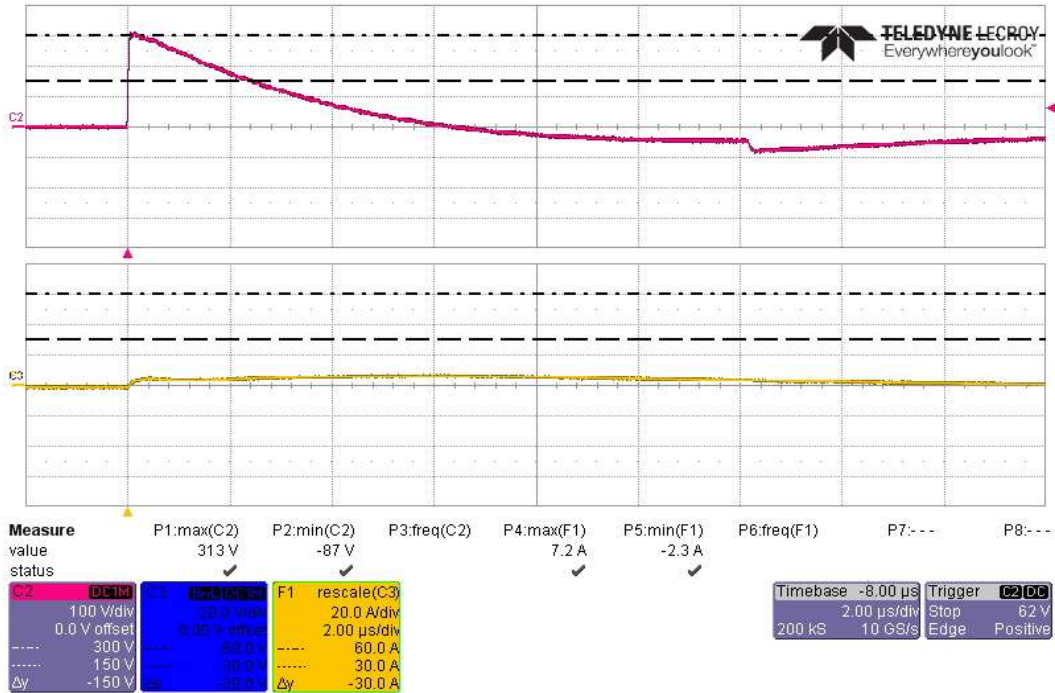

Actual CS117 Voltage Waveform #2 Test, First Transient +300V/60A on PV Return Side

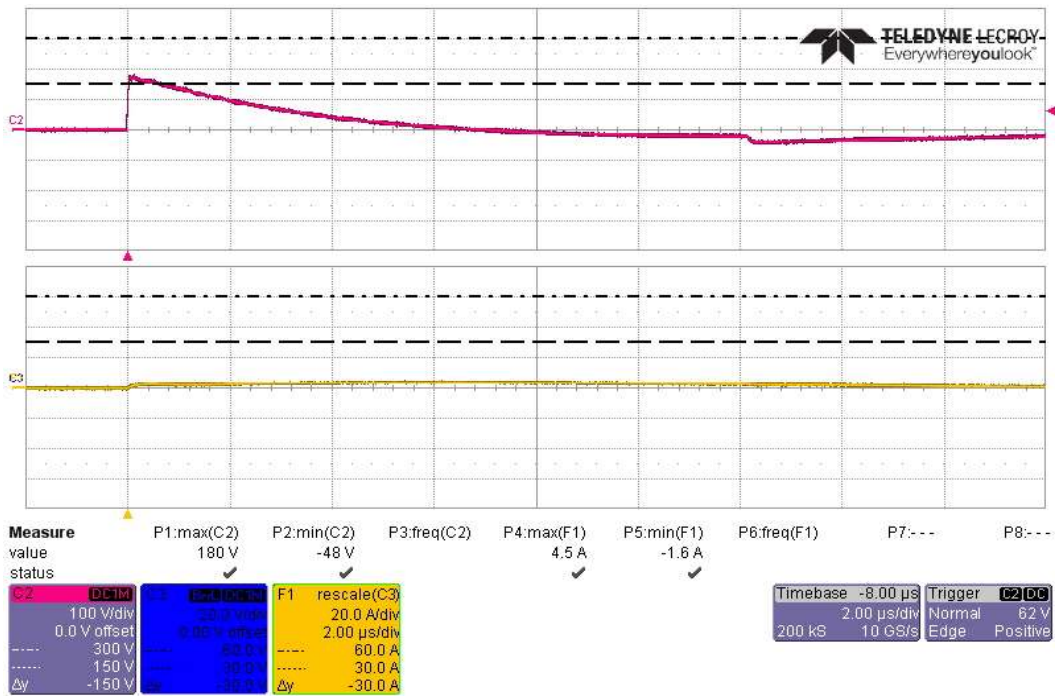

Actual CS117 Voltage Waveform #2 Test, Subsequent Transient +150V/30A on PV Return Side

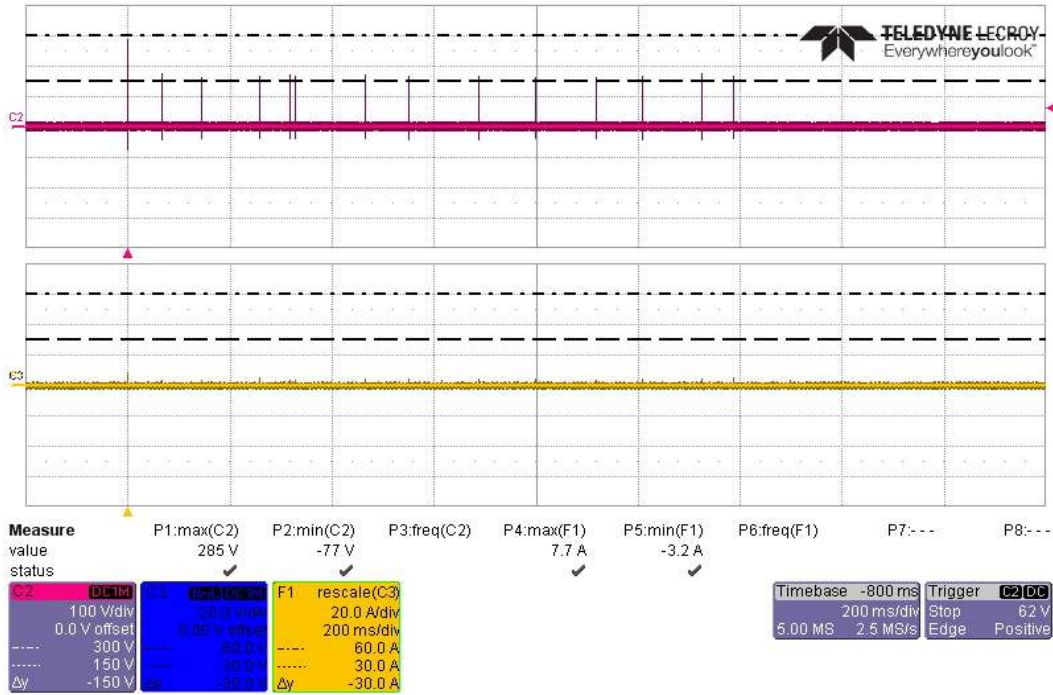

Actual CS117 Voltage Waveform #2 Test, 14 Transient +300V/60A & +150V/30A on PV Return Side

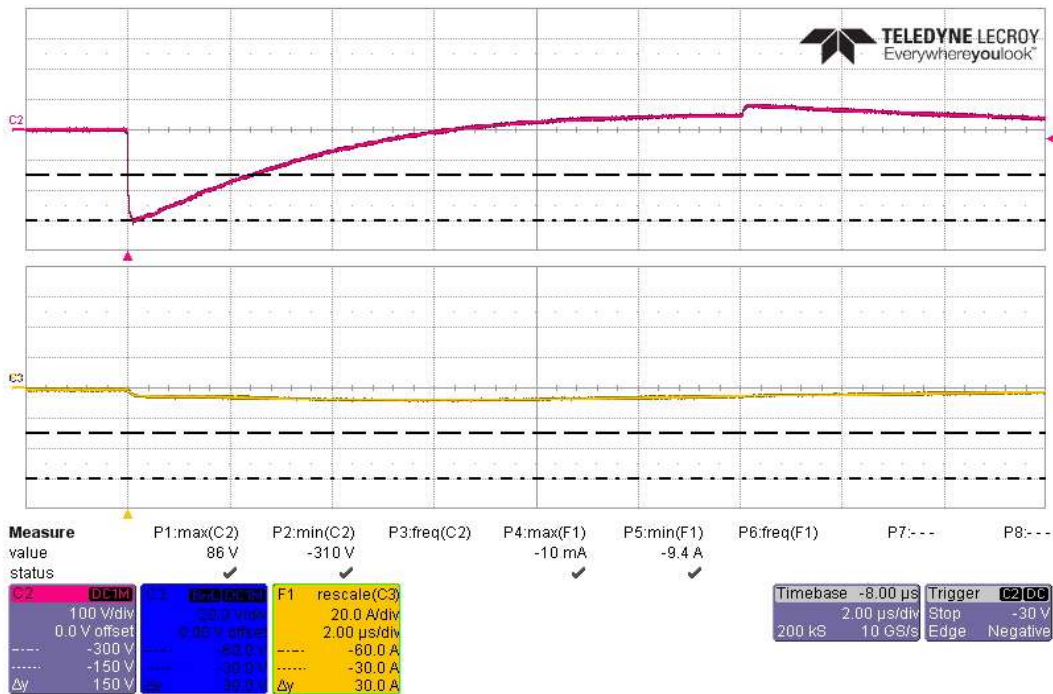

Actual CS117 Voltage Waveform #2 Test, First Transient -300V/60A on PV Return Side

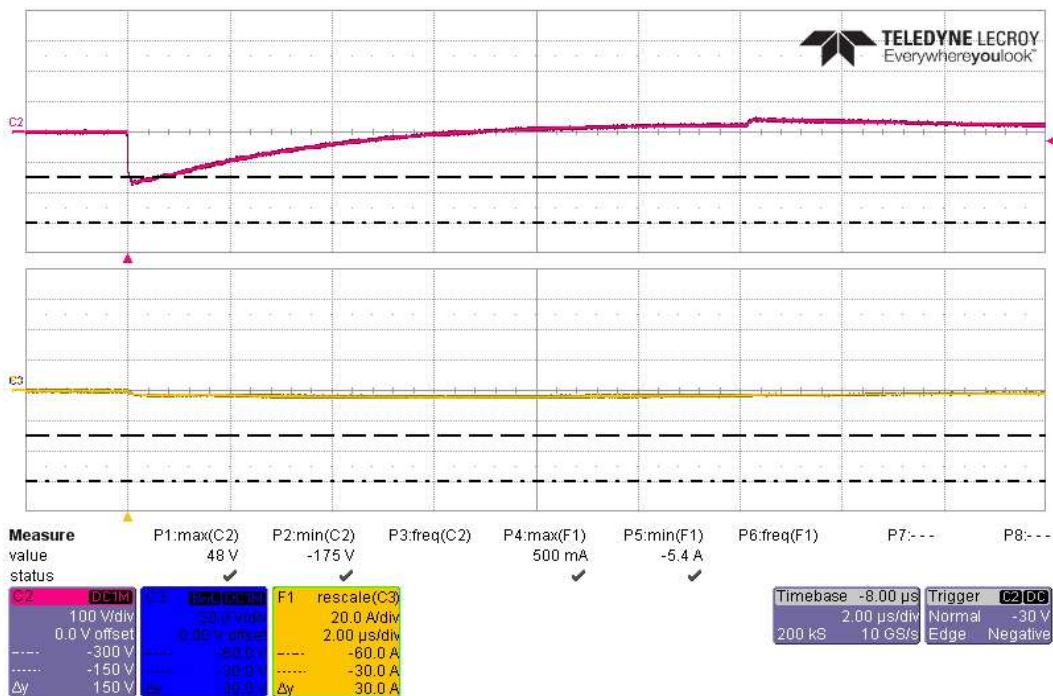

Actual CS117 Voltage Waveform #2 Test, Subsequent Transient -150V/30A on PV Return Side

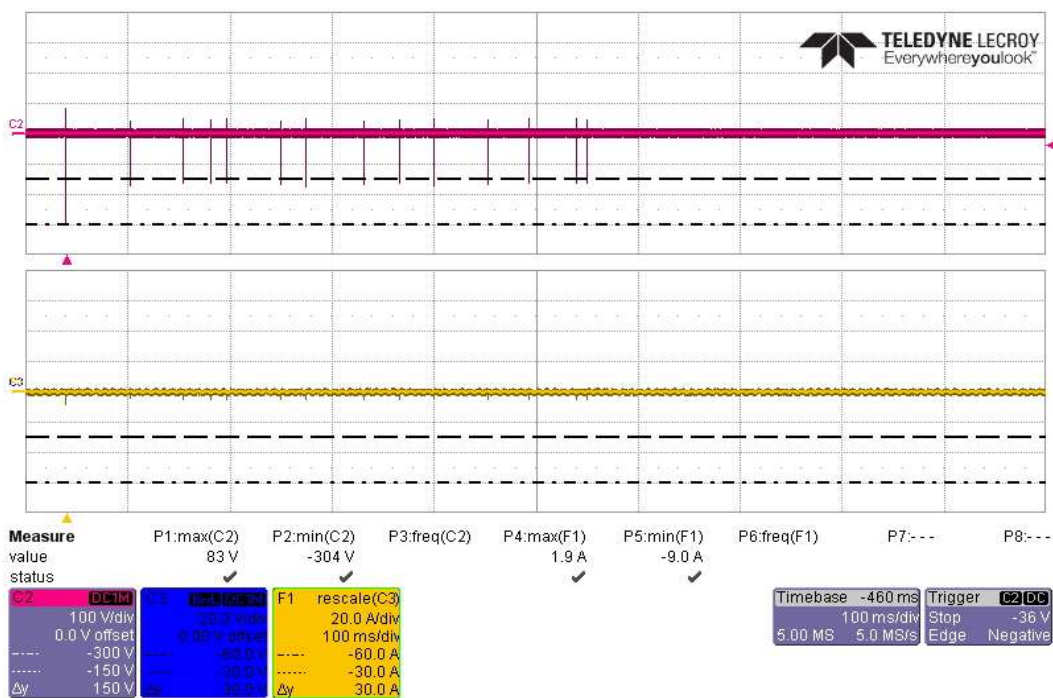

Actual CS117 Voltage Waveform #2 Test, 14 Transient -300V/60A & -150V/30A on PV Return Side

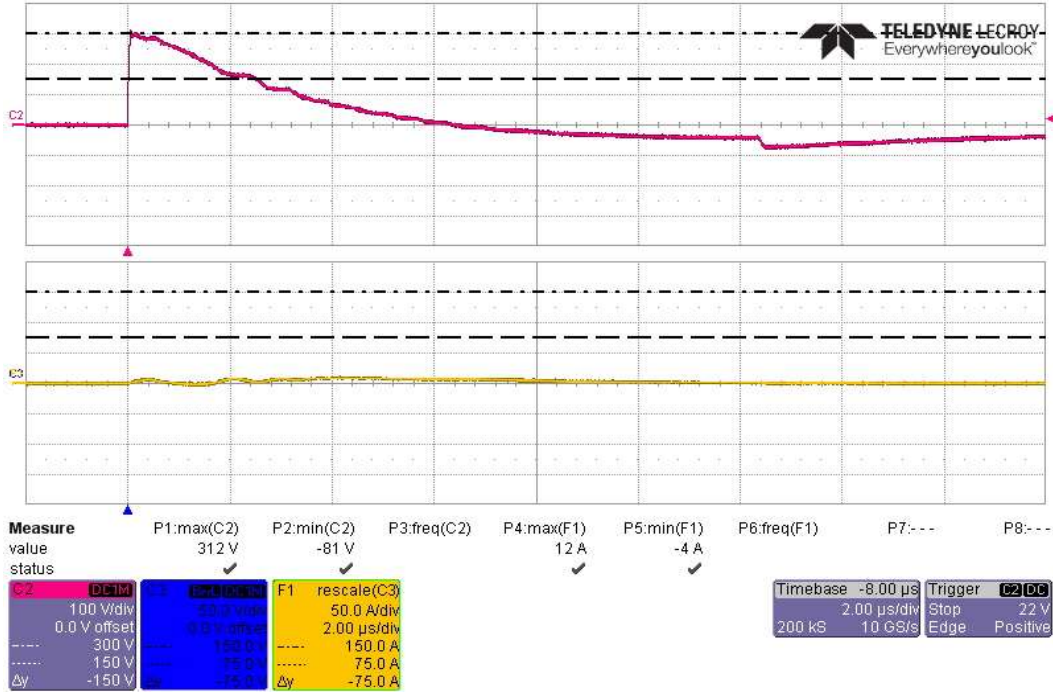

Actual CS117 Voltage Waveform #2 Test, First Transient +300V/120A on PV Bundle

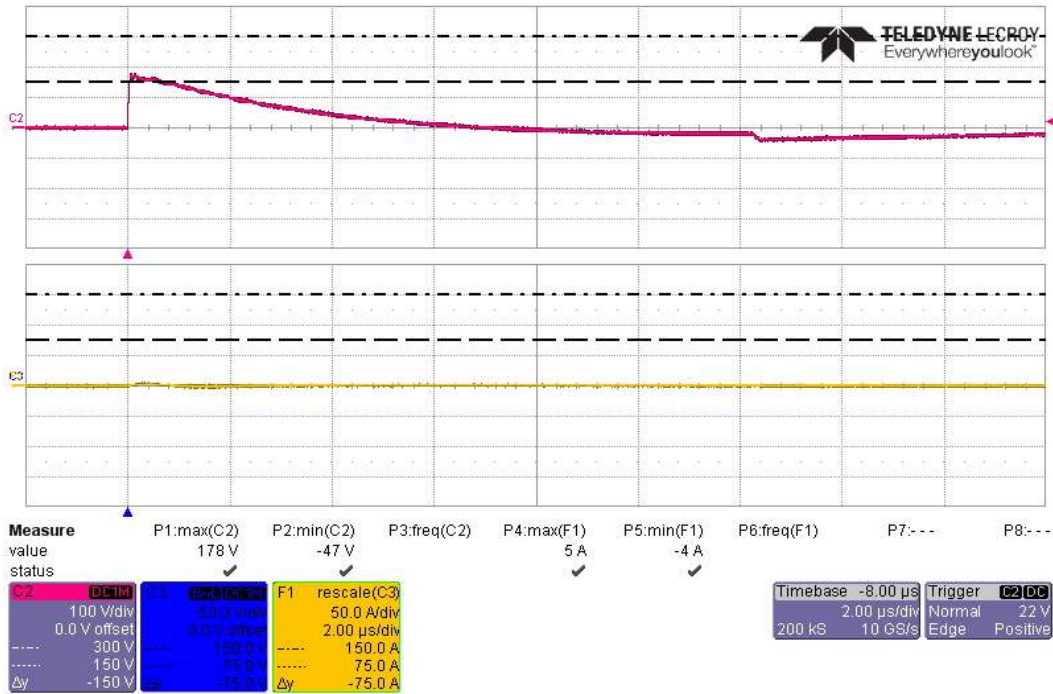

Actual CS117 Voltage Waveform #2 Test, Subsequent Transient +150V/60A on PV Bundle

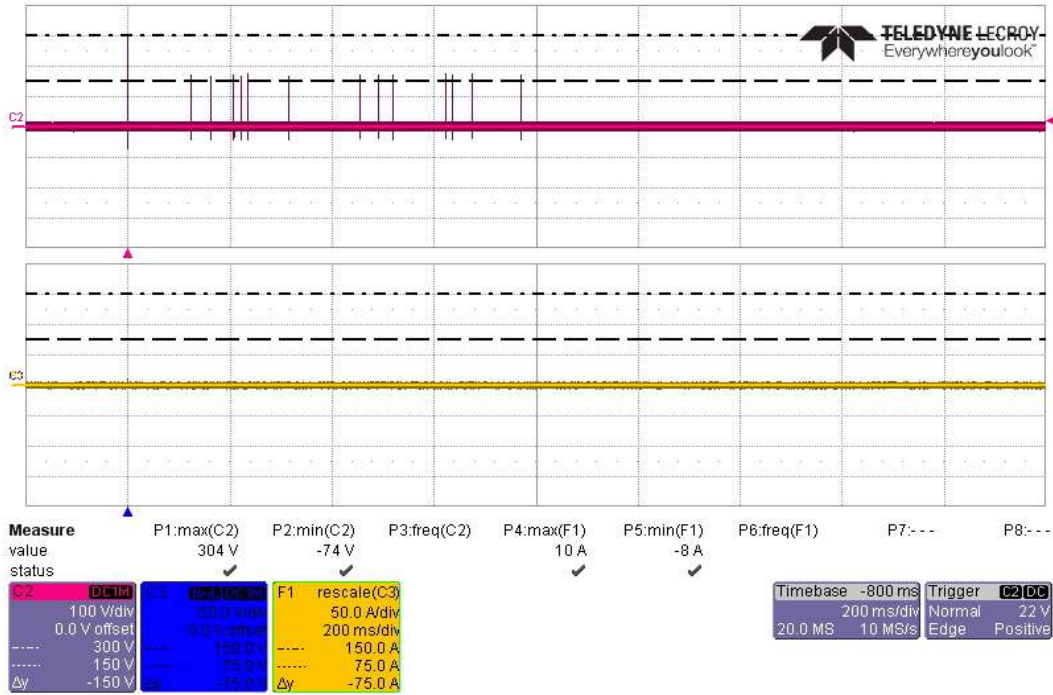

Actual CS117 Voltage Waveform #2 Test, 14 Transient +300V/120A & +150V/60A on PV Bundle

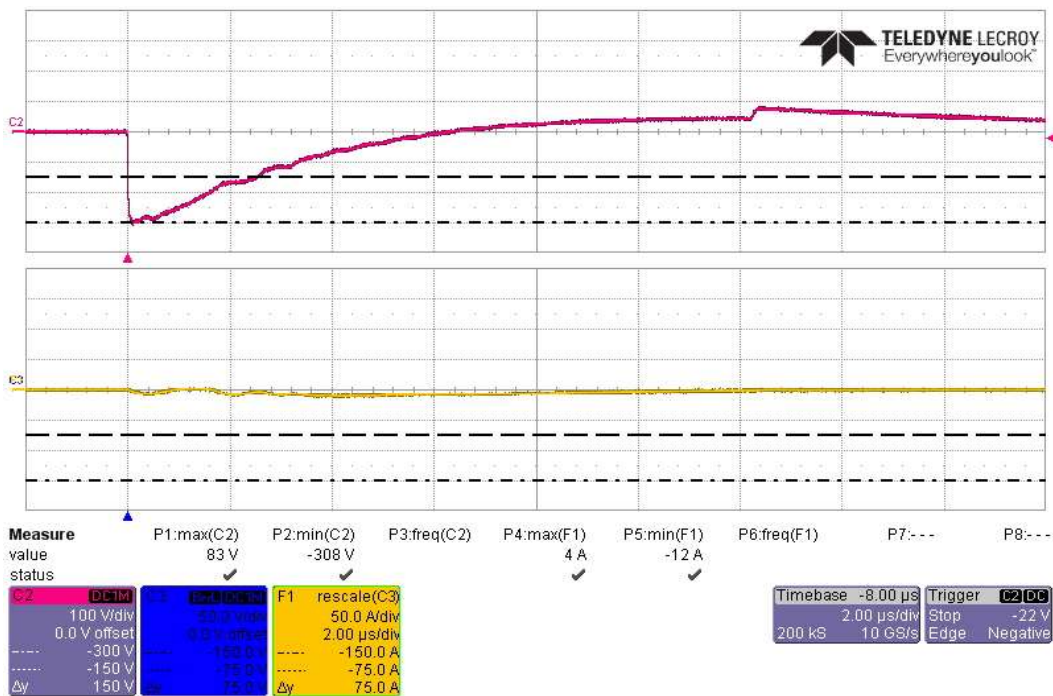

Actual CS117 Voltage Waveform #2 Test, First Transient -300V/120A on PV Bundle

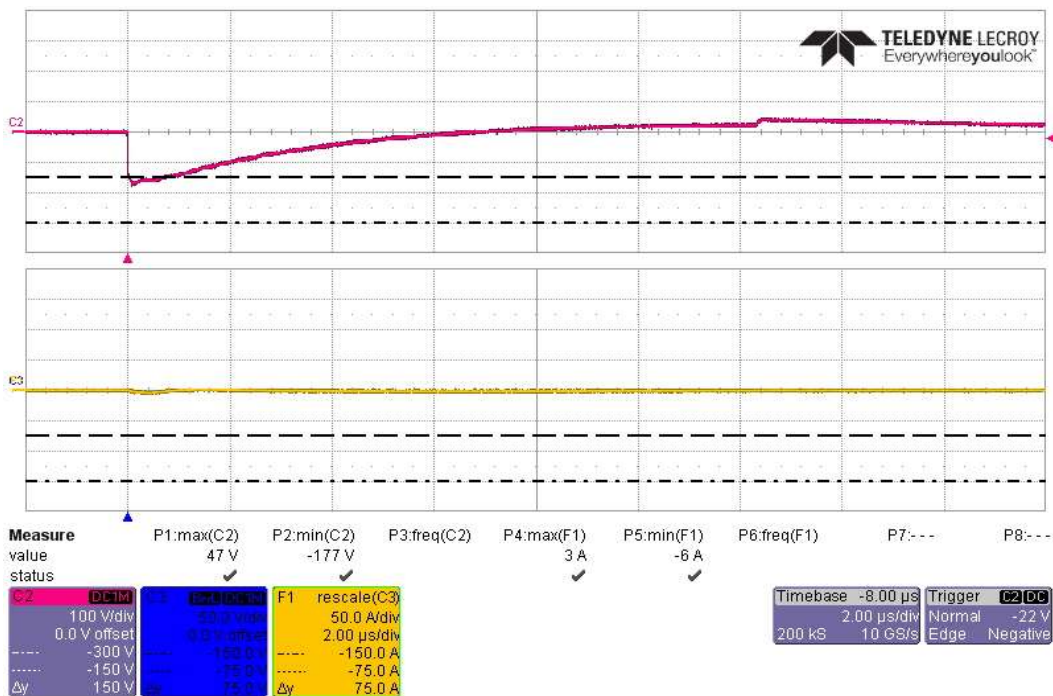

Actual CS117 Voltage Waveform #2 Test, Subsequent Transient -150V/60A on PV Bundle

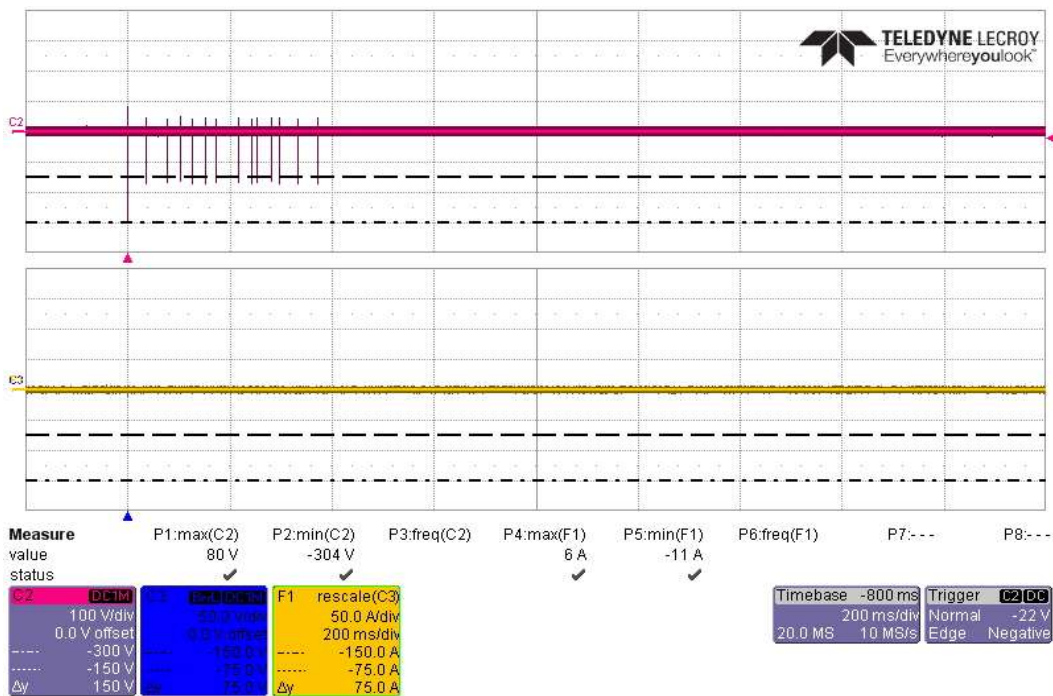

Actual CS117 Voltage Waveform #2 Test, 14 Transient -300V/120A & -150V/60A on PV Bundle

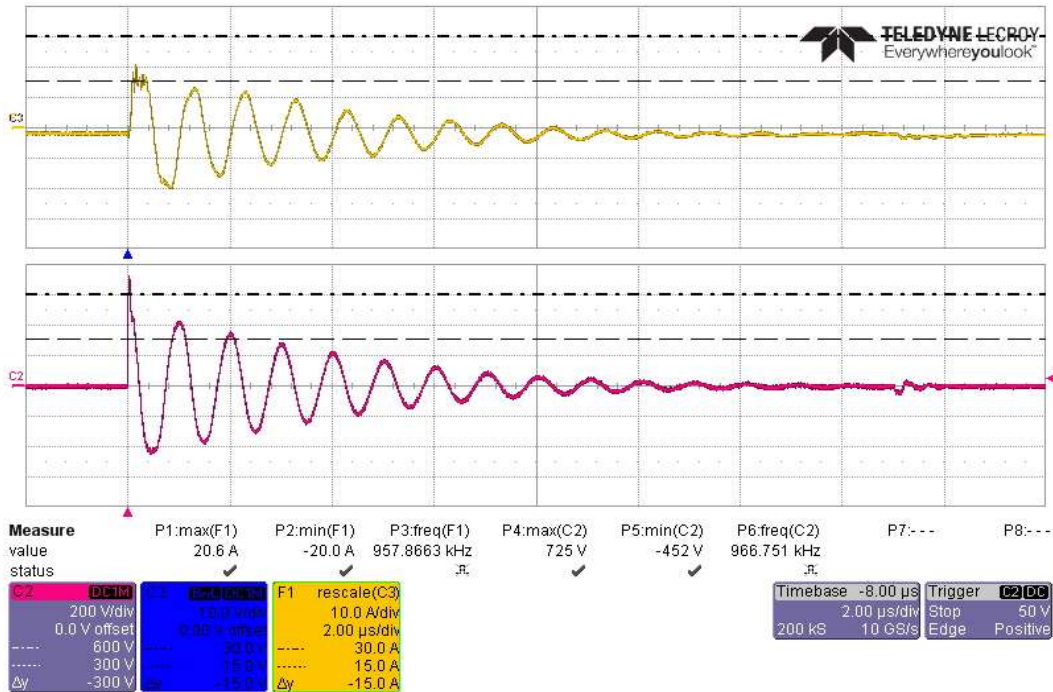
CS117 Actual Test MS Waveform #3 at 1MHz with 600V/24A

Actual Test CS117 MS Waveform #3 at 1MHz, First Transient +600V, on Power Line 1

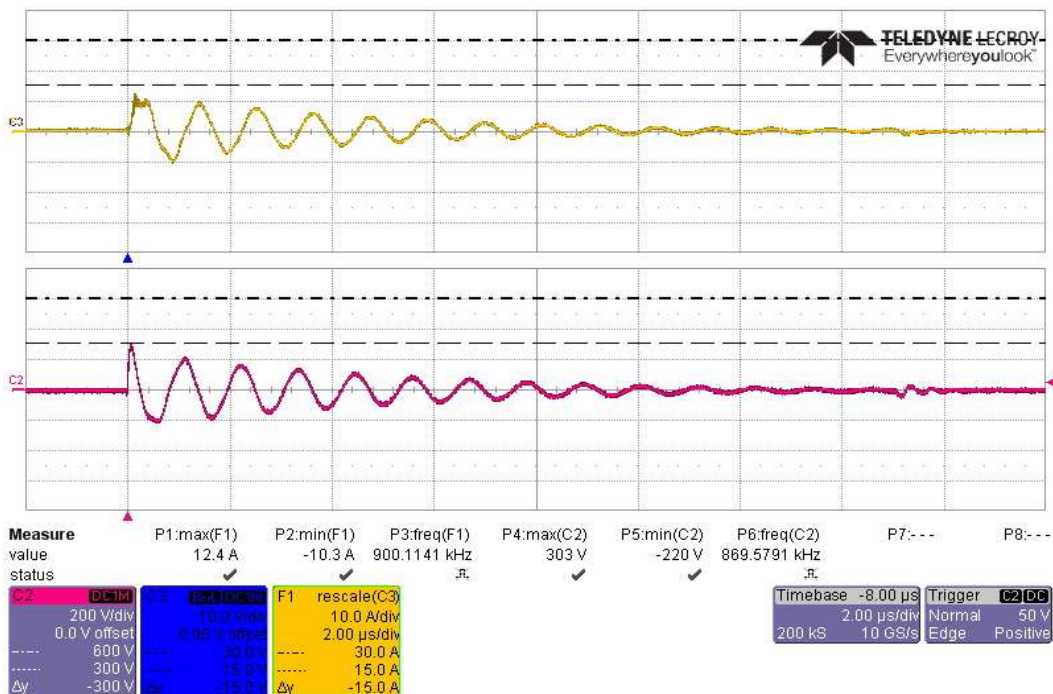

Actual Test CS117 MS Waveform #3 at 1MHz, Subsequent Transient +300V, on Power Line 1

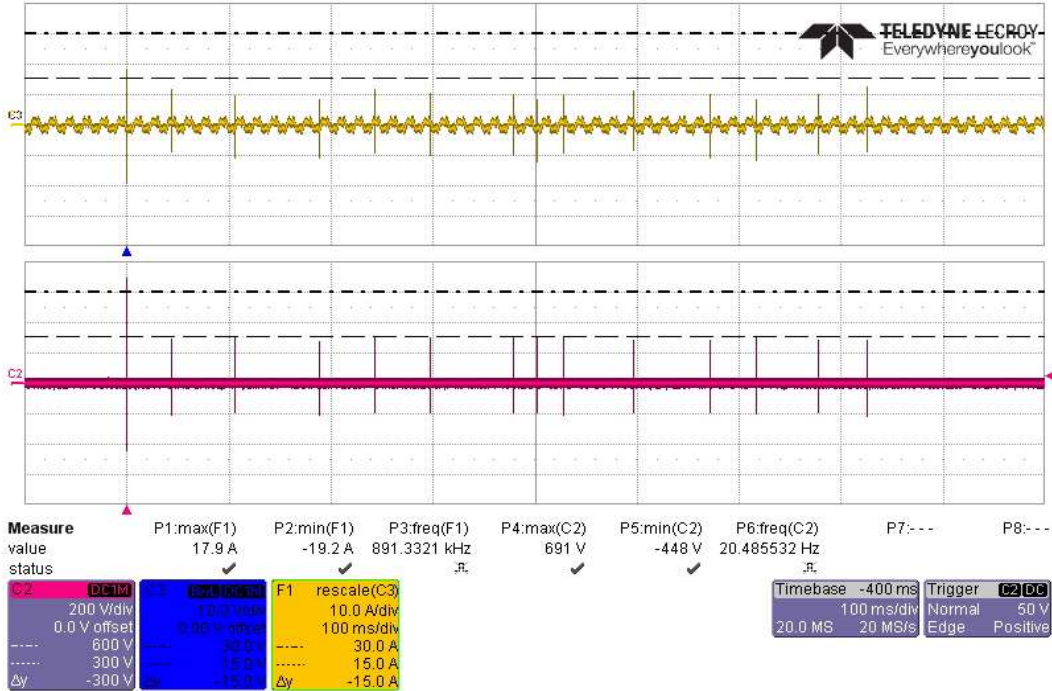

Actual Test CS117 MS Waveform #3 at 1MHz, 14 Transients +600/+300V, on Power Line 1

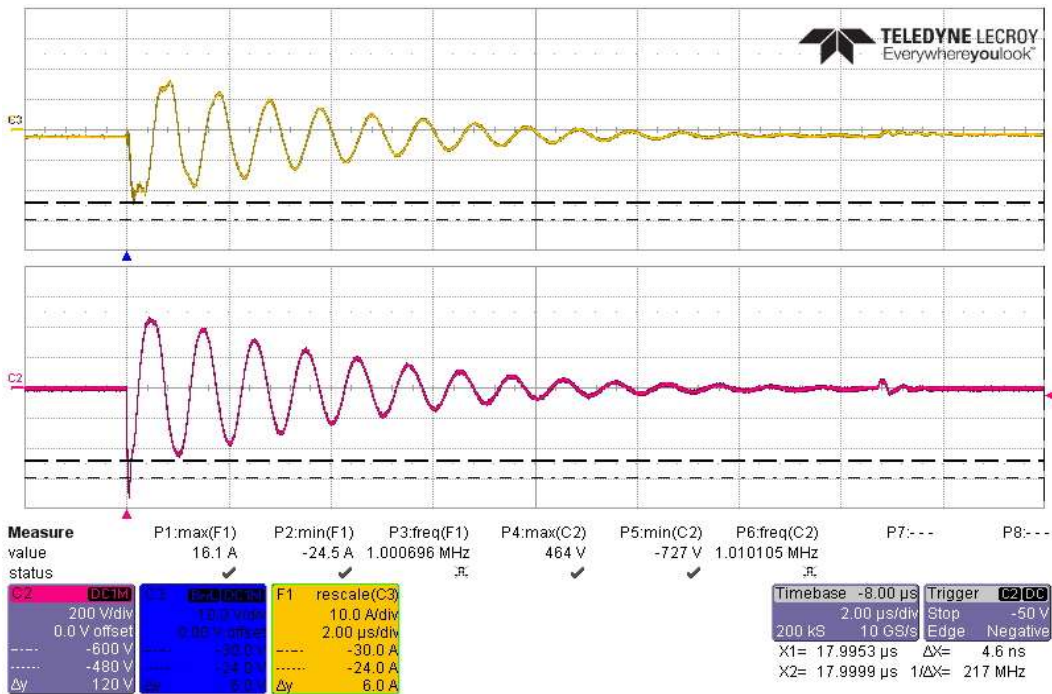

Actual Test CS117 MS Waveform #3 at 1MHz, First Transient -600V, on Power Line 1

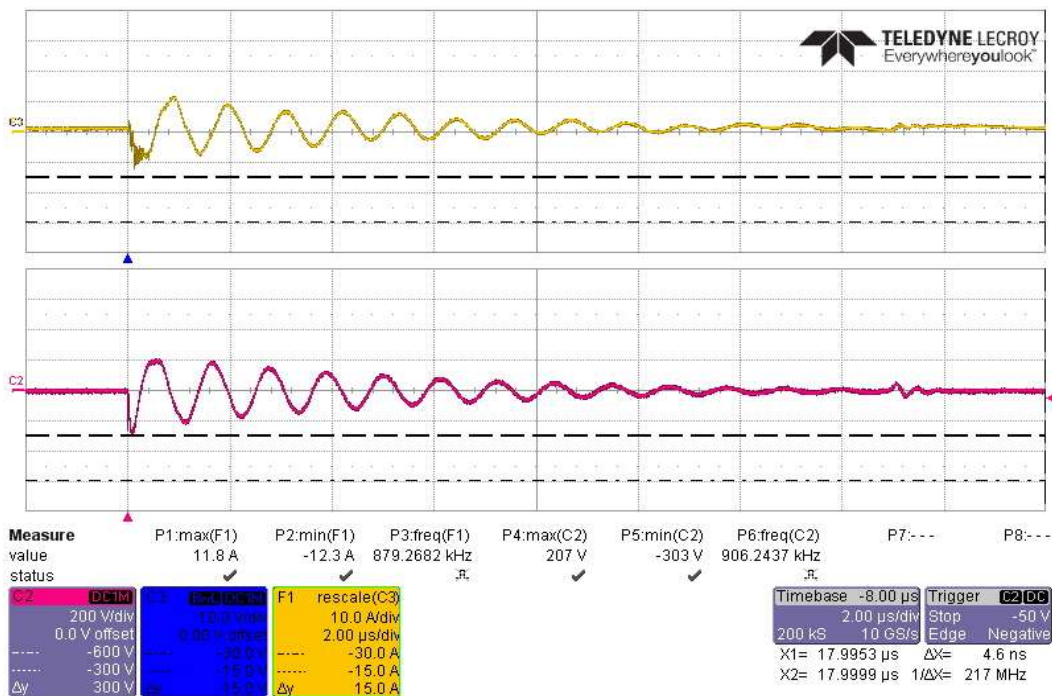

Actual Test CS117 MS Waveform #3 at 1MHz, Subsequent Transient -300V, on Power Line 1

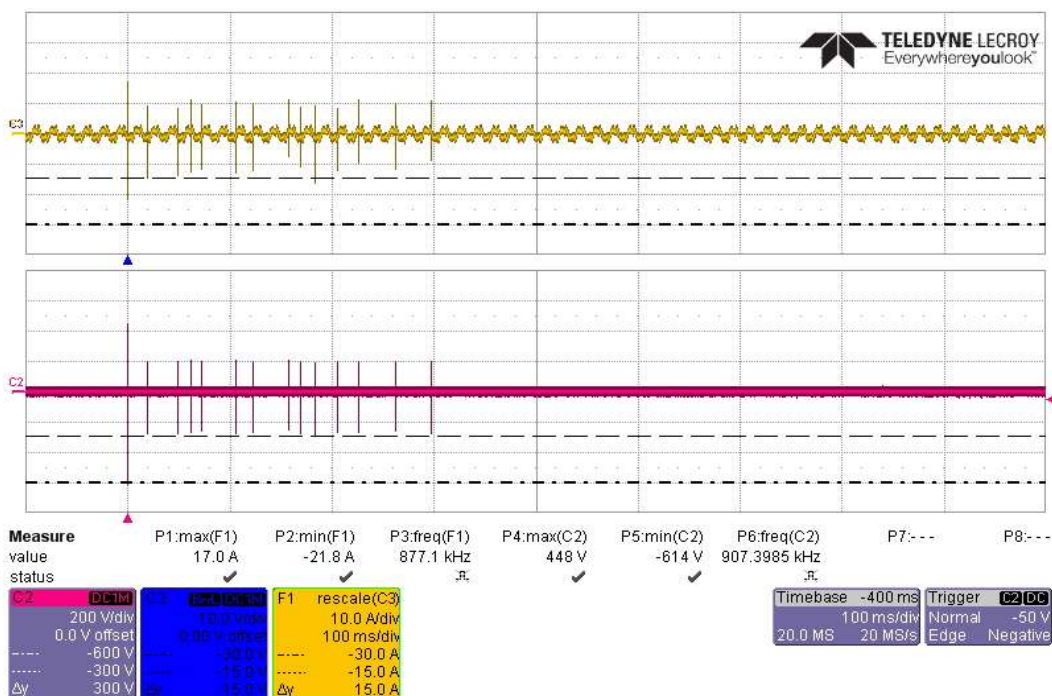

Actual Test CS117 MS Waveform #3 at 1MHz, 14 Transients -600/-300V, on Power Line 1

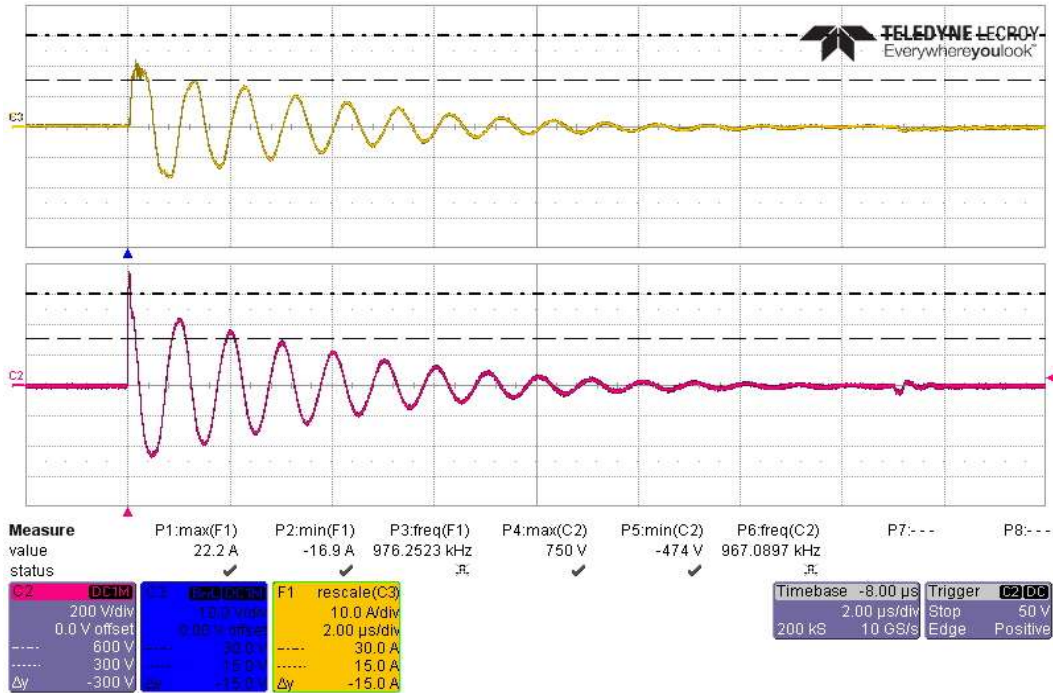

Actual Test CS117 MS Waveform #3 at 1MHz, First Transient +600V, on Power Line 2

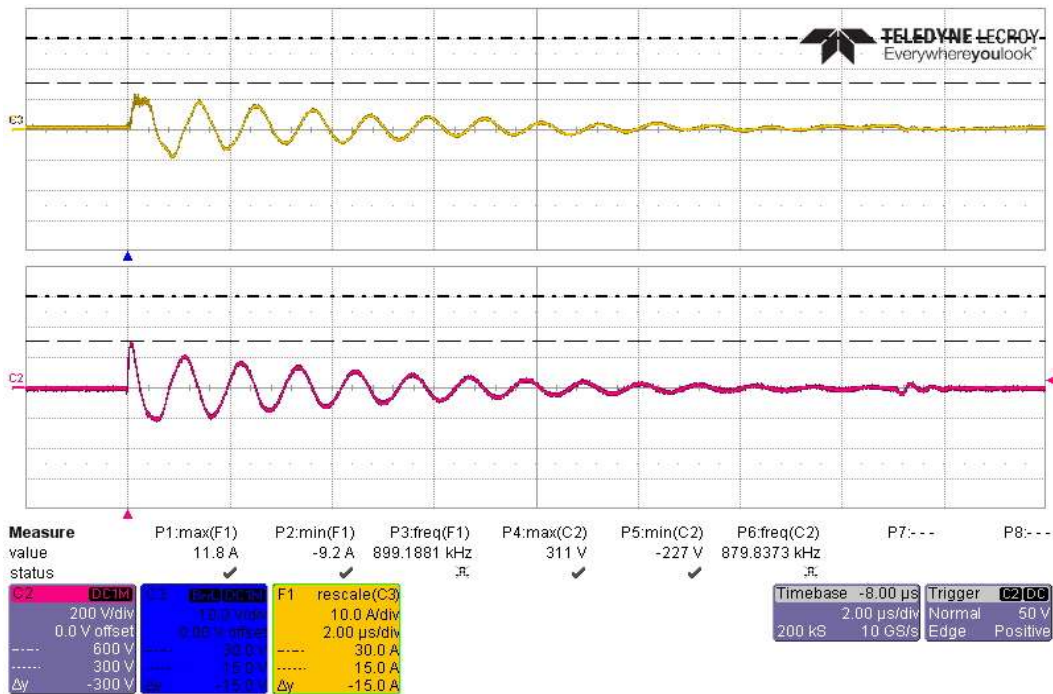

Actual Test CS117 MS Waveform #3 at 1MHz, Subsequent Transient +300V, on Power Line 2

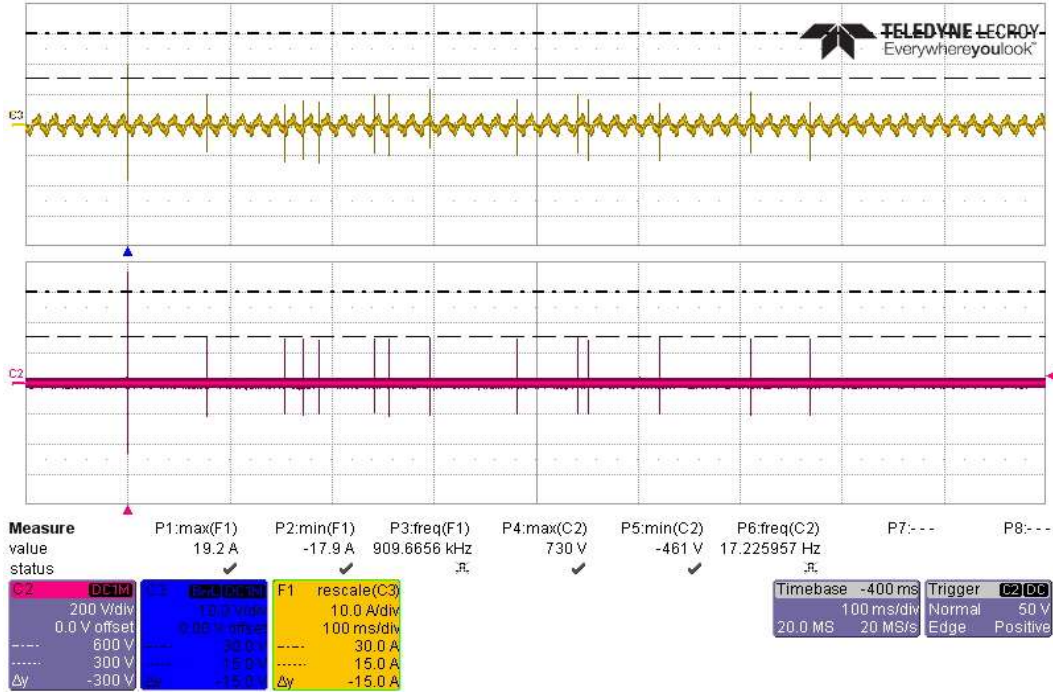

Actual Test CS117 MS Waveform #3 at 1MHz, 14 Transients +600/+300V, on Power Line 2

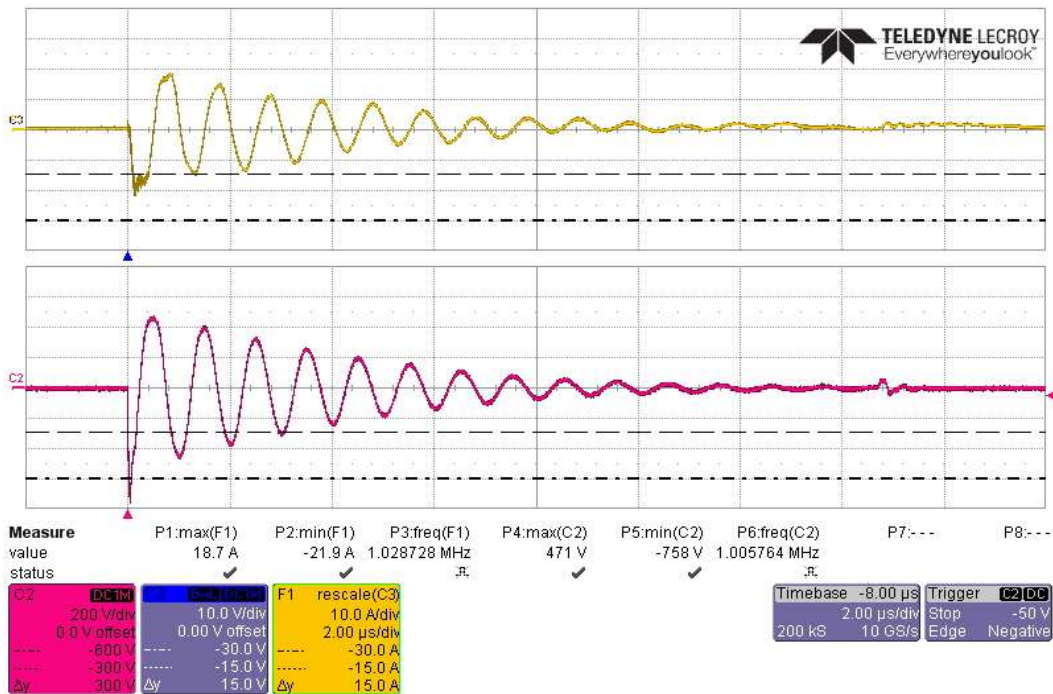

Actual Test CS117 MS Waveform #3 at 1MHz, First Transient -600V, on Power Line 2

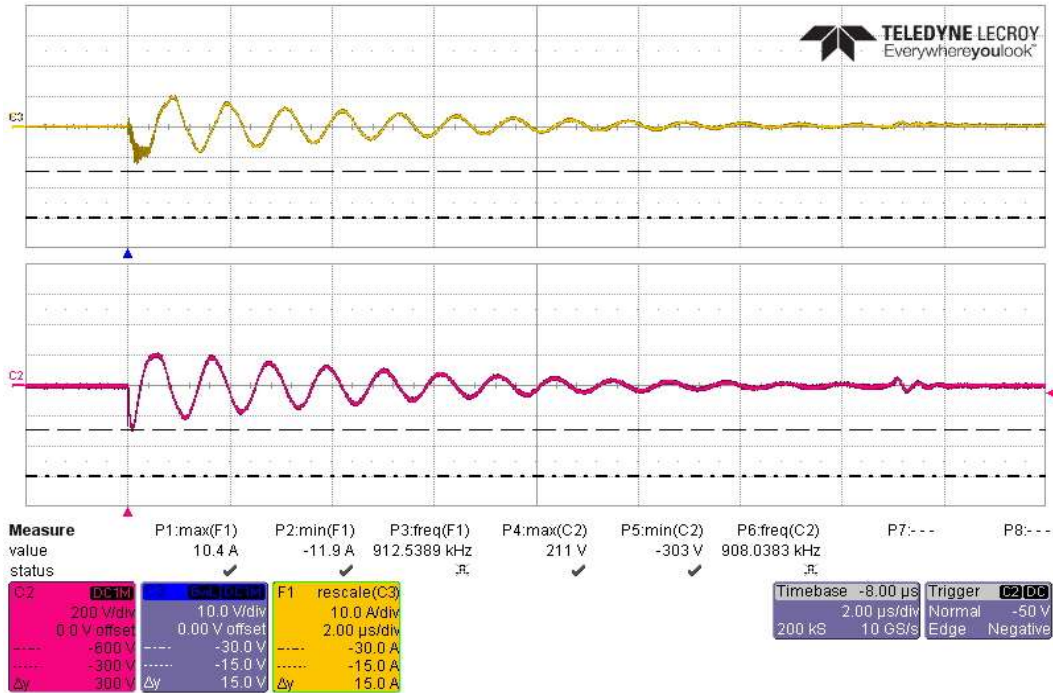

Actual Test CS117 MS Waveform #3 at 1MHz, Subsequent Transient -300V, on Power Line 2

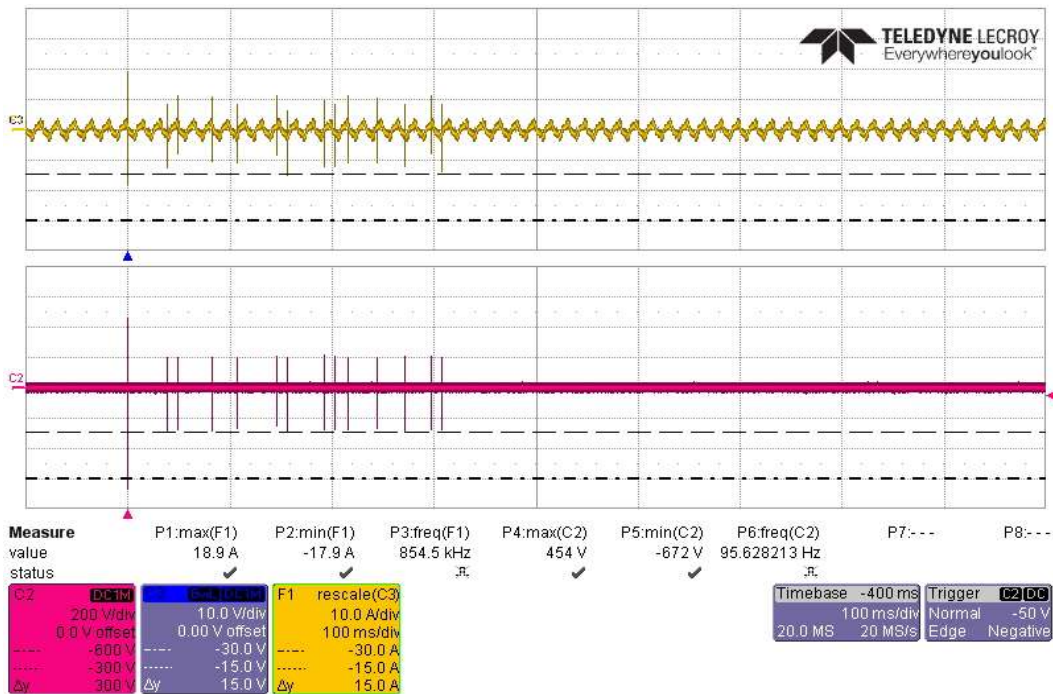

Actual Test CS117 MS Waveform #3 at 1MHz, 14 Transients -600/-300V, on Power Line 2

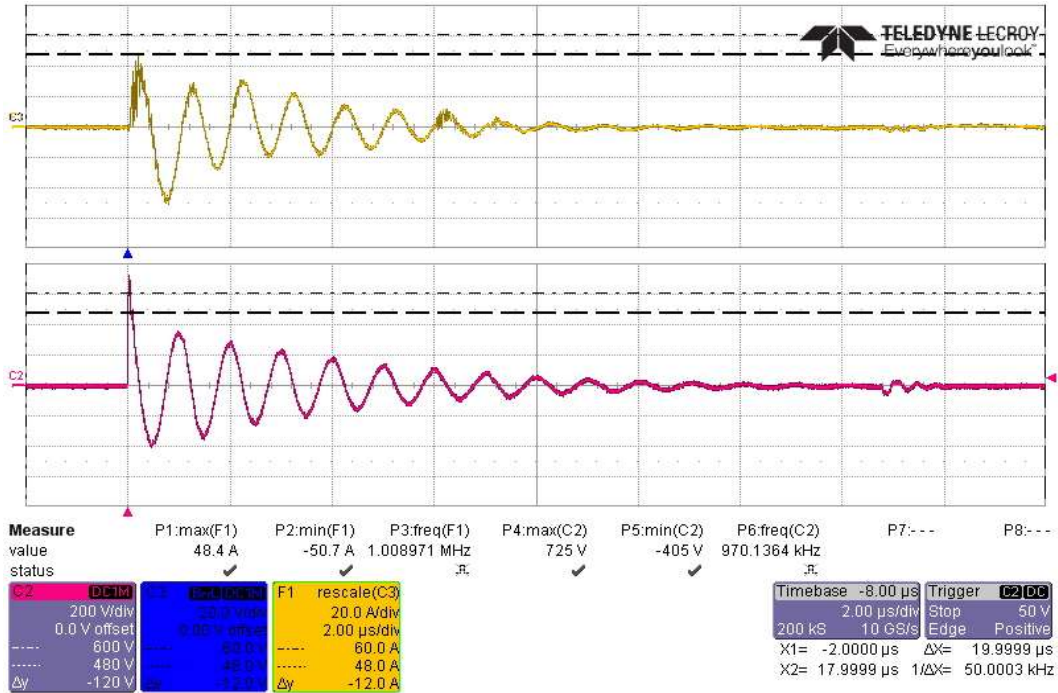

Actual Test CS117 MS Waveform #3 at 1MHz, First Transient +600V, on Power Lines

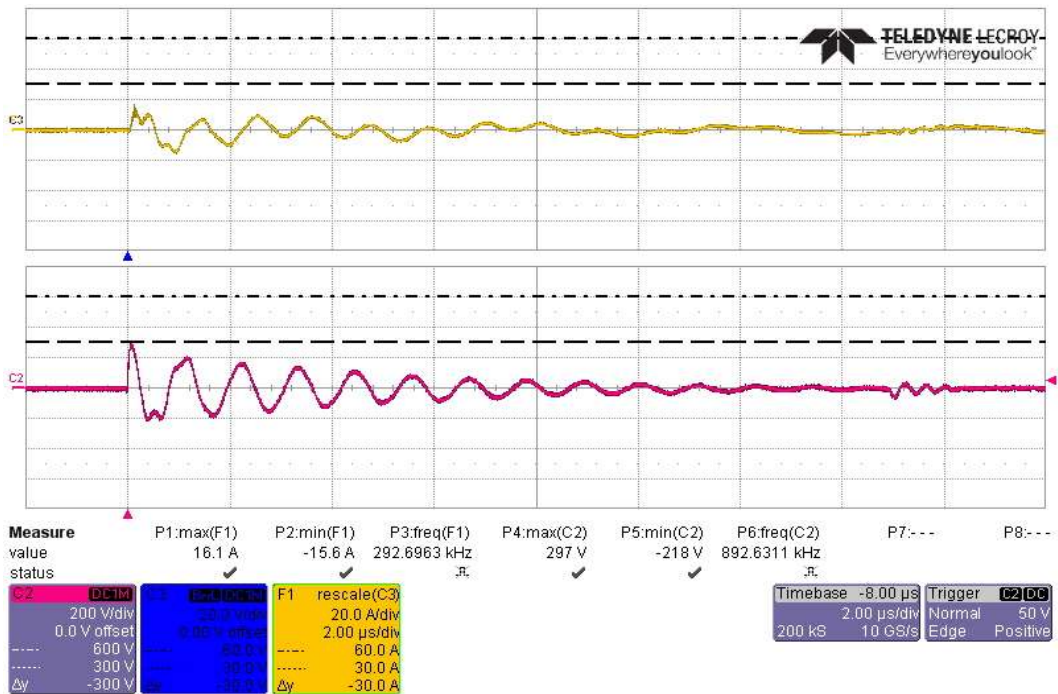

Actual Test CS117 MS Waveform #3 at 1MHz, Subsequent Transient +300V, on Power Lines

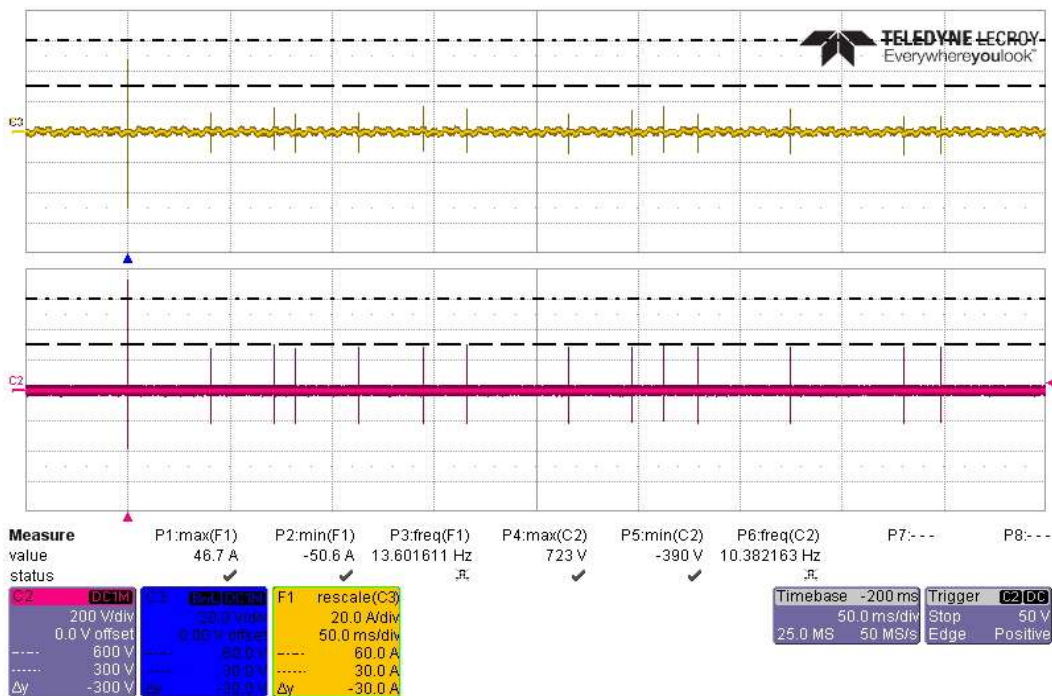

Actual Test CS117 MS Waveform #3 at 1MHz, 14 Transients +600/+300V, on Power Lines

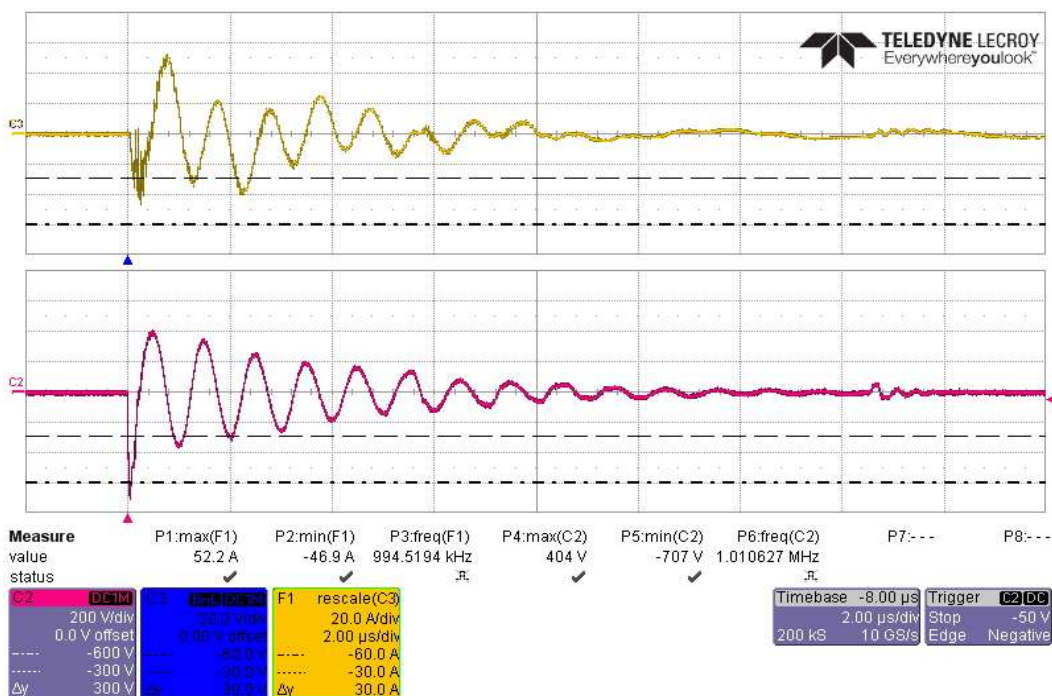

Actual Test CS117 MS Waveform #3 at 1MHz, First Transient -600V, on Power Lines

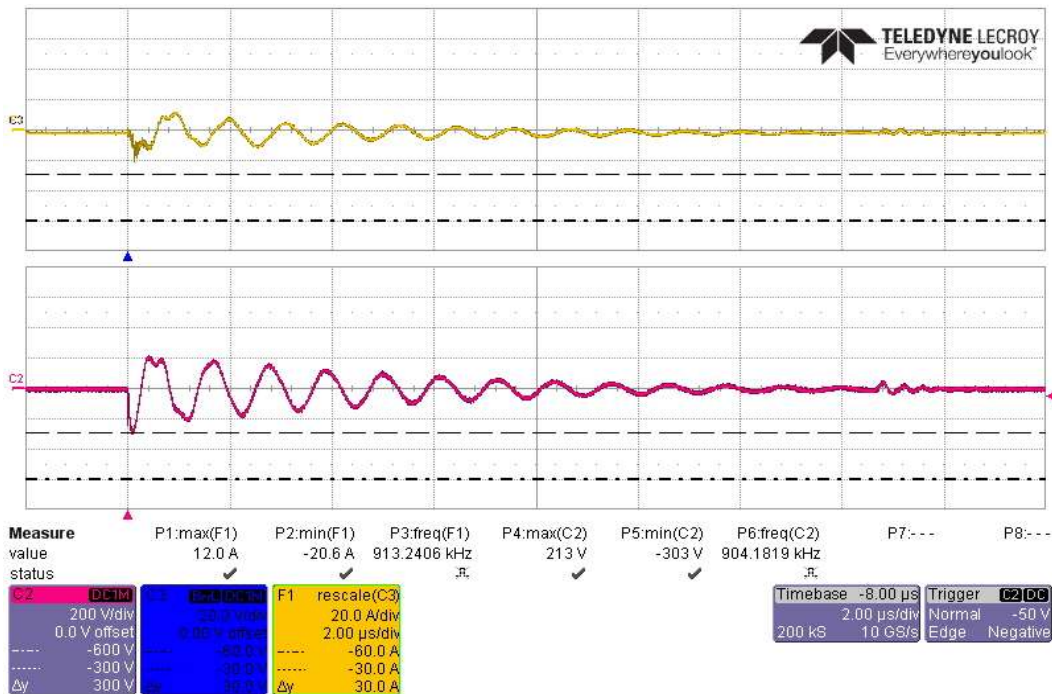

Actual Test CS117 MS Waveform #3 at 1MHz, Subsequent Transient -300V, on Power Lines

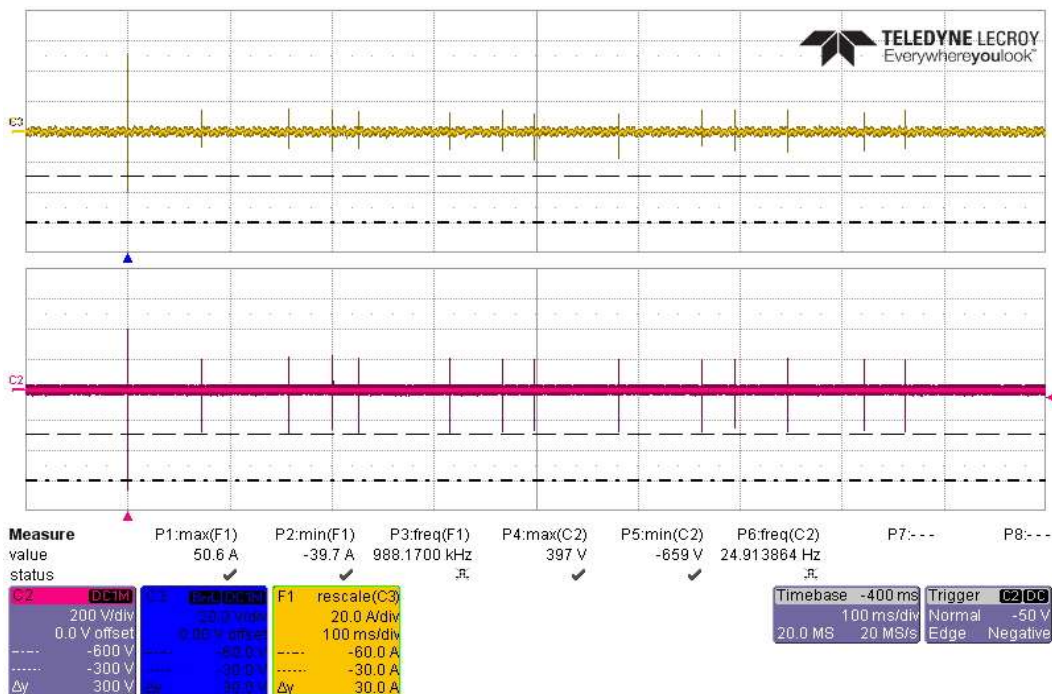

Actual Test CS117 MS Waveform #3 at 1MHz, 14 Transients -600/-300V, on Power Lines

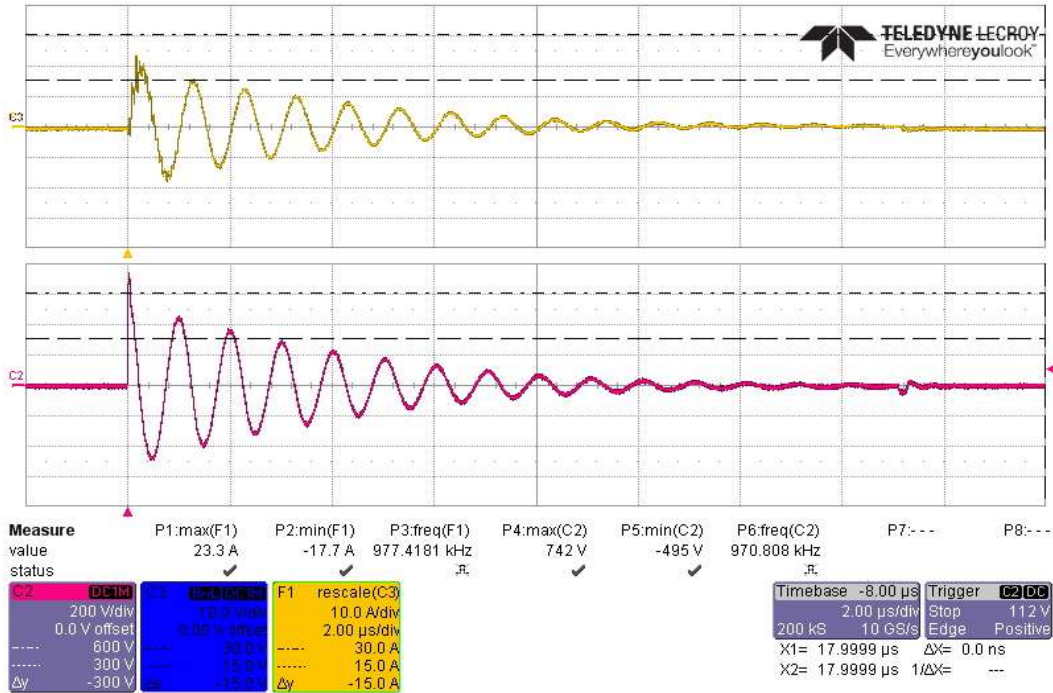

Actual Test CS117 MS Waveform #3 at 1MHz, First Transient +600V, on Battery High Side

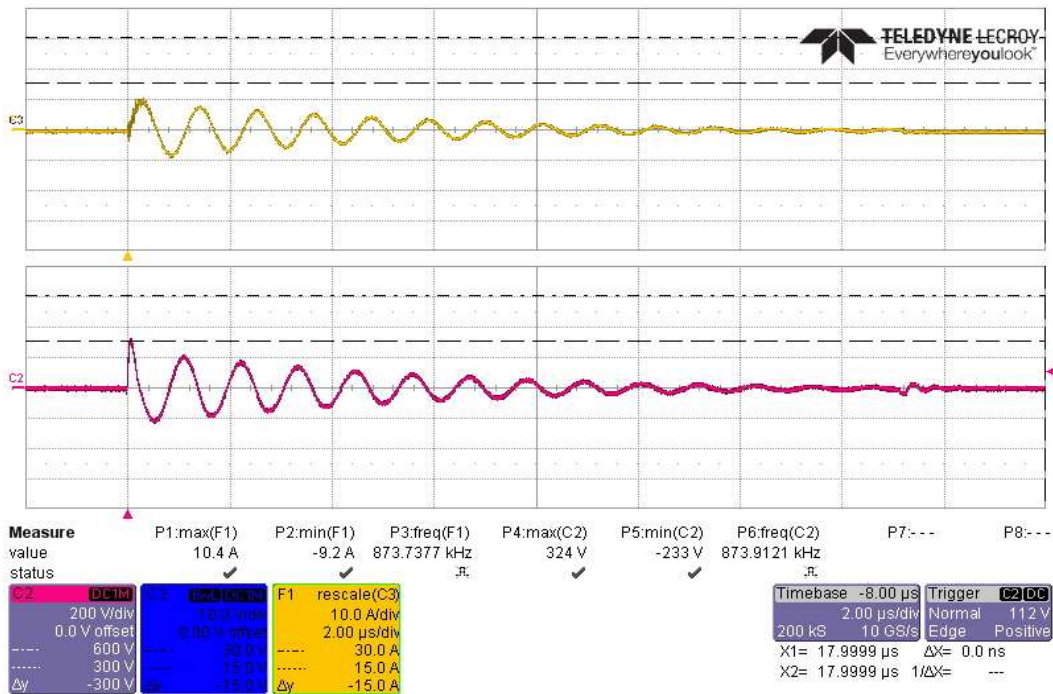

Actual Test CS117 MS Waveform #3 at 1MHz, Subsequent Transient +300V, on Battery High Side

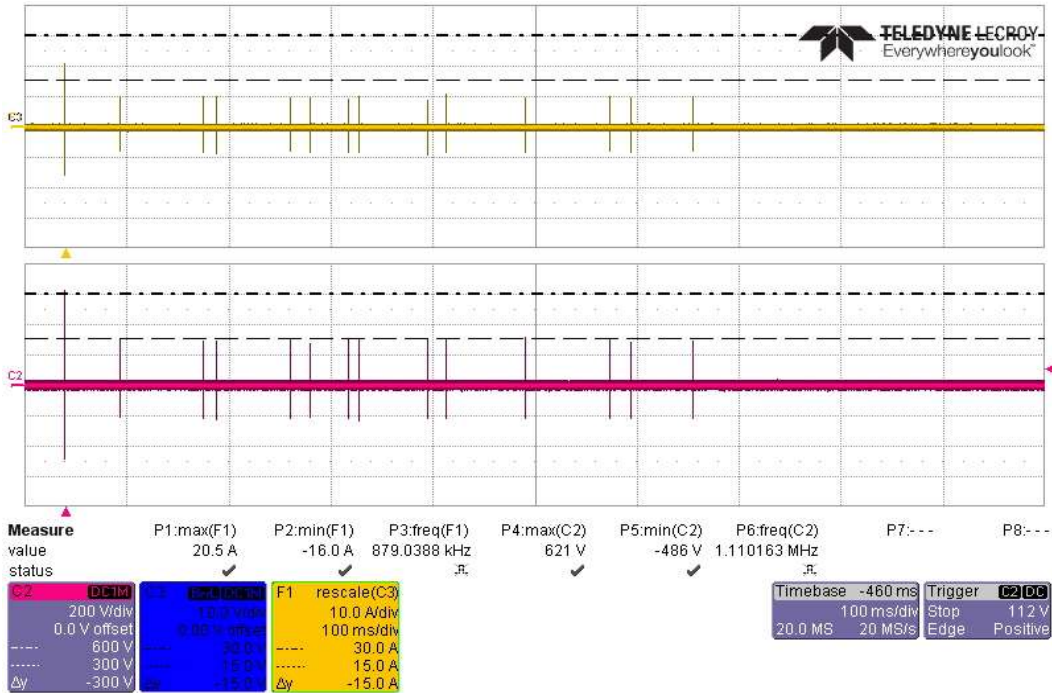

Actual Test CS117 MS Waveform #3 at 1MHz, 14 Transients +600/+300V, on Battery High Side

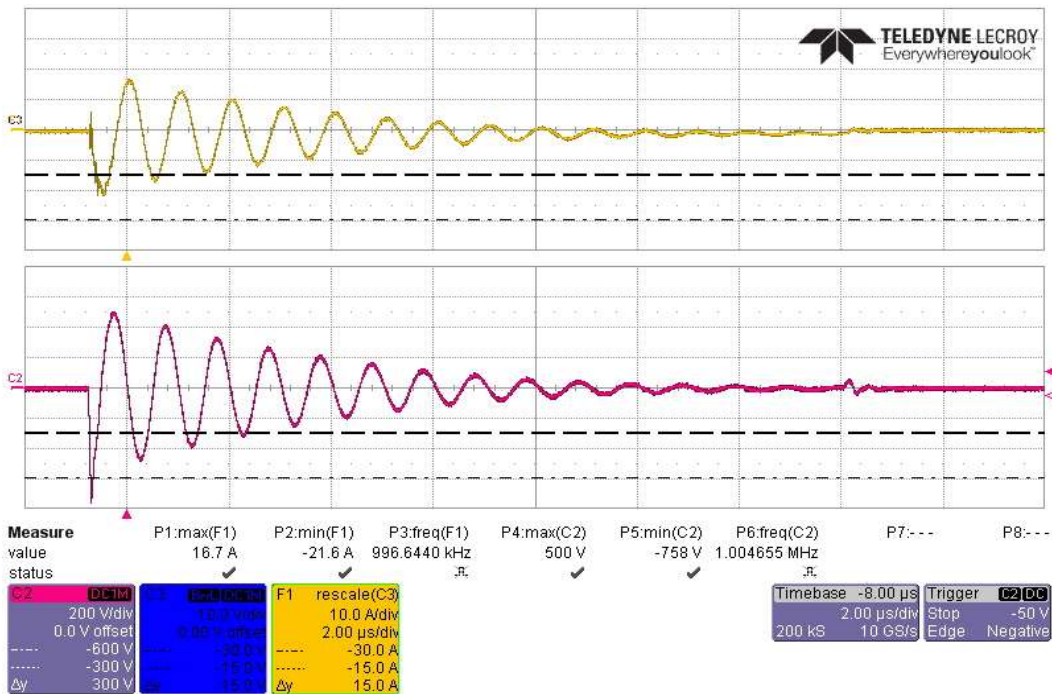

Actual Test CS117 MS Waveform #3 at 1MHz, First Transient -600V, on Battery High Side

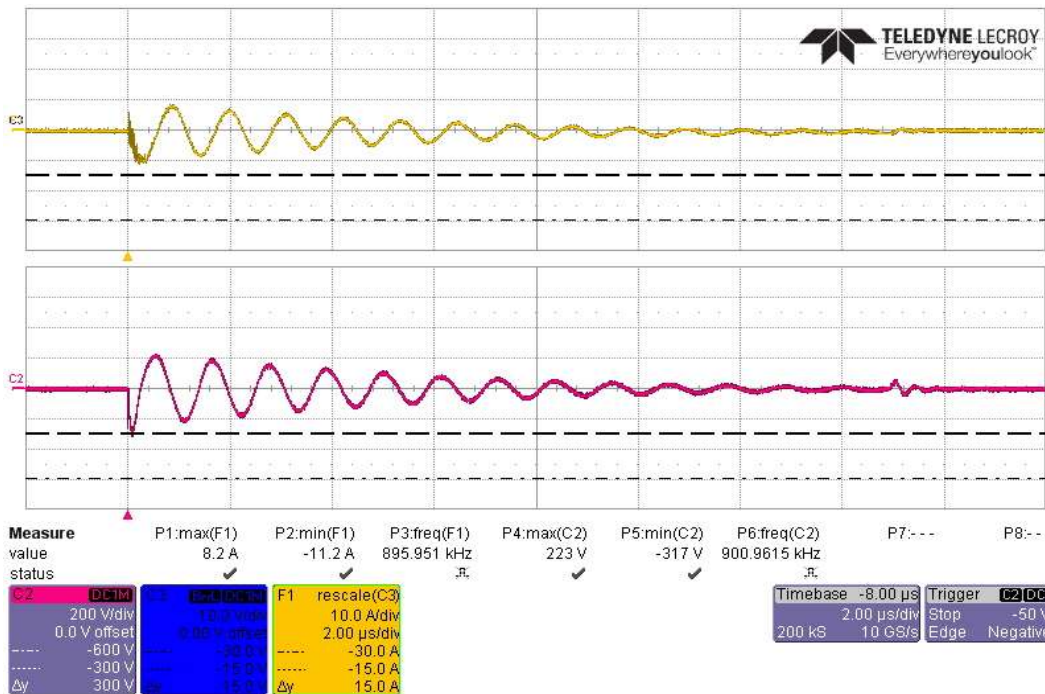

Actual Test CS117 MS Waveform #3 at 1MHz, Subsequent Transient -300V, on Battery High Side

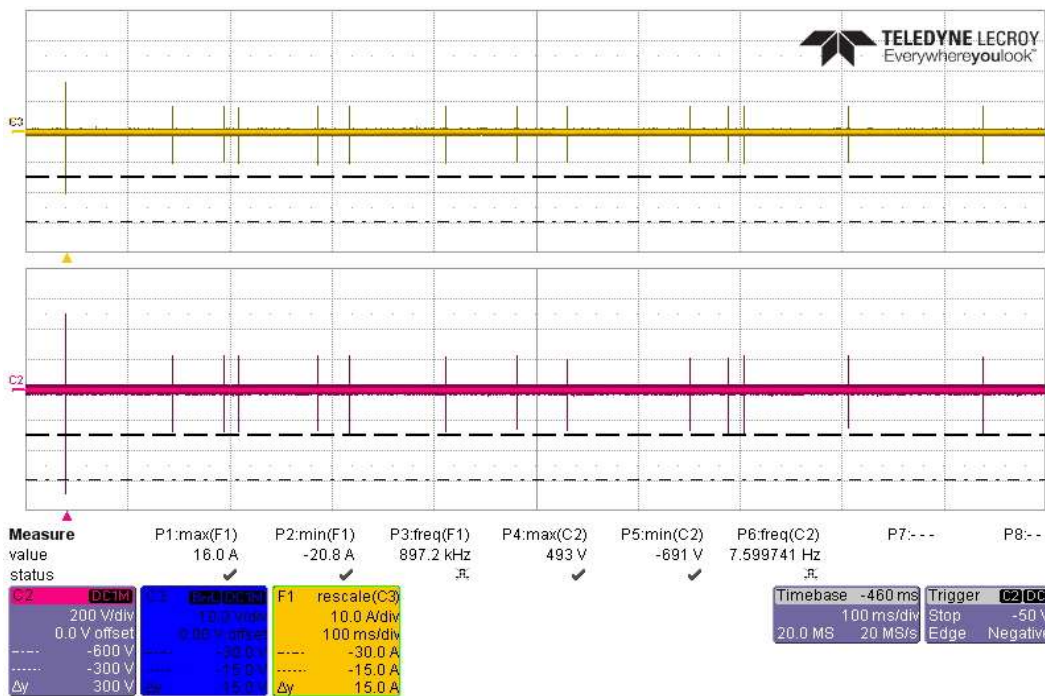

Actual Test CS117 MS Waveform #3 at 1MHz, 14 Transients -600/-300V, on Battery High Side

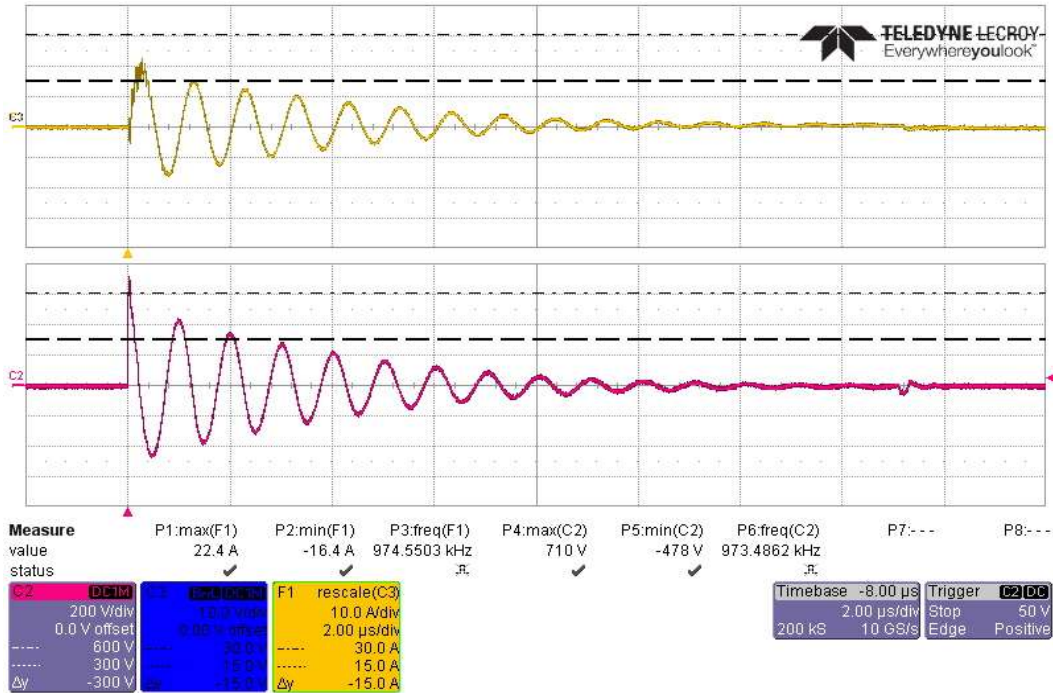

Actual Test CS117 MS Waveform #3 at 1MHz, First Transient +600V, on Battery Return Side

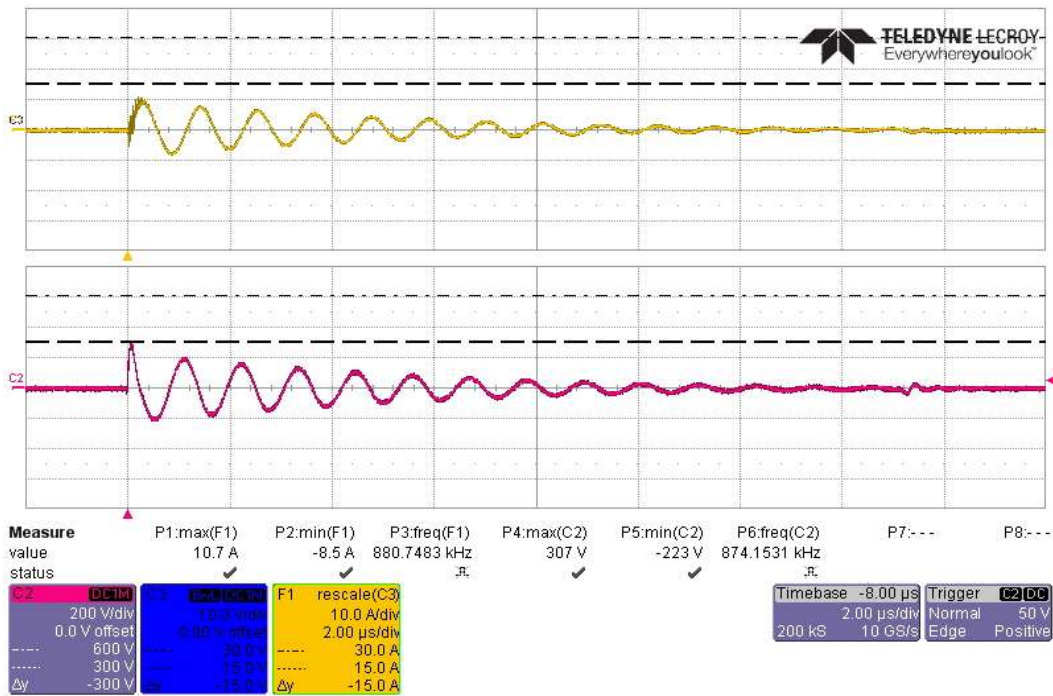

Actual Test CS117 MS Waveform #3 at 1MHz, Subsequent Transient +300V, on Battery Return Side

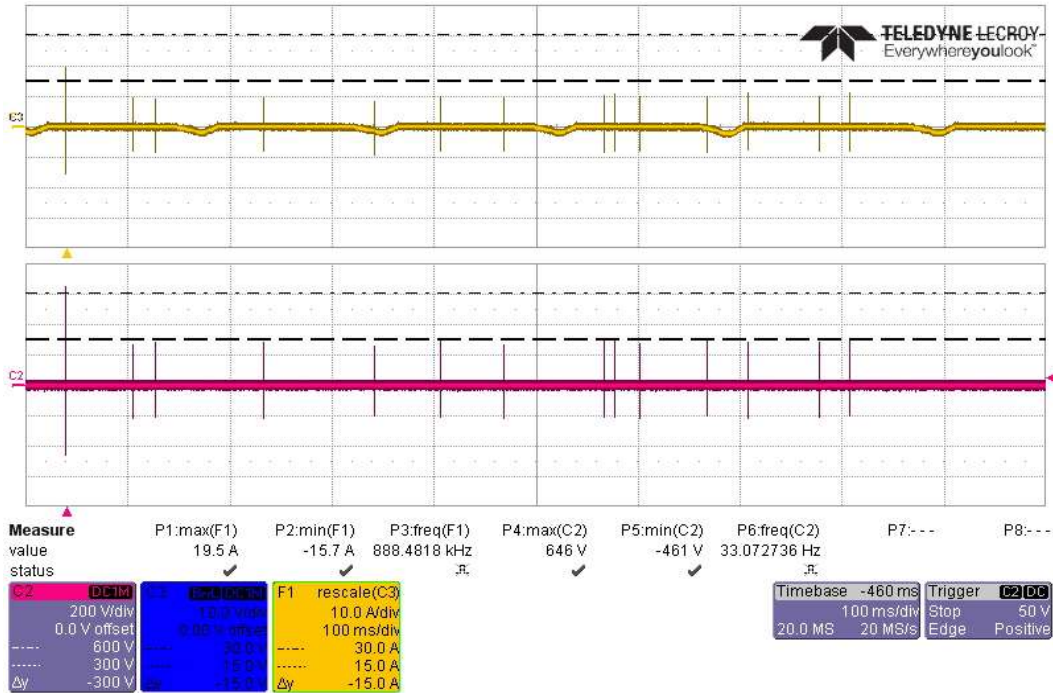

Actual Test CS117 MS Waveform #3 at 1MHz, 14 Transients +600/+300V, on Battery Return Side

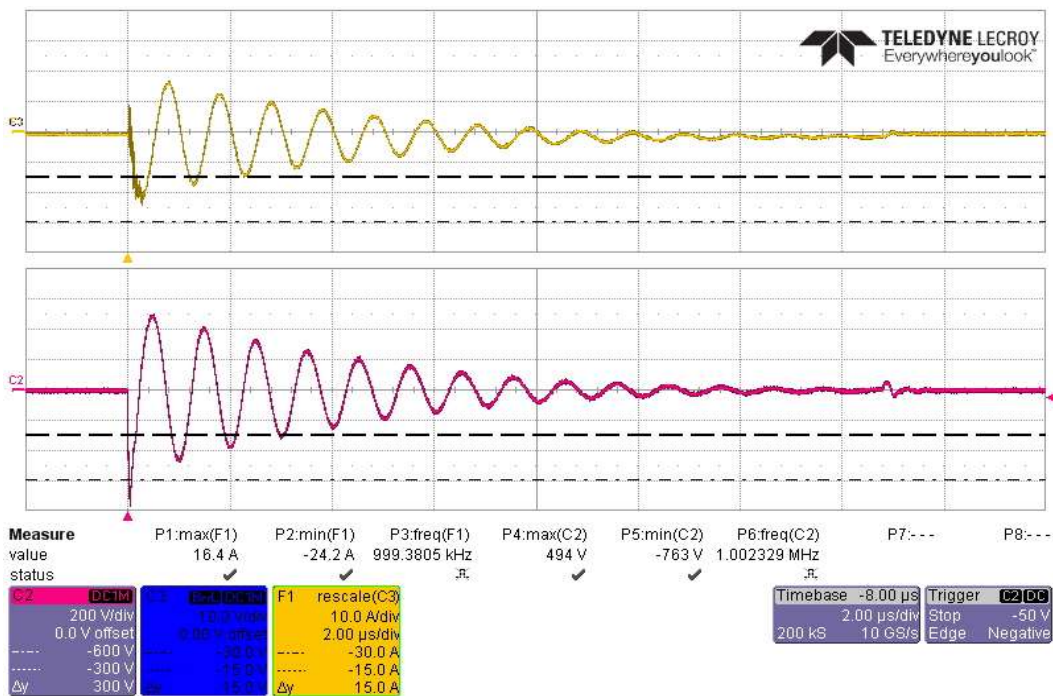

Actual Test CS117 MS Waveform #3 at 1MHz, First Transient -600V, on Battery Return Side

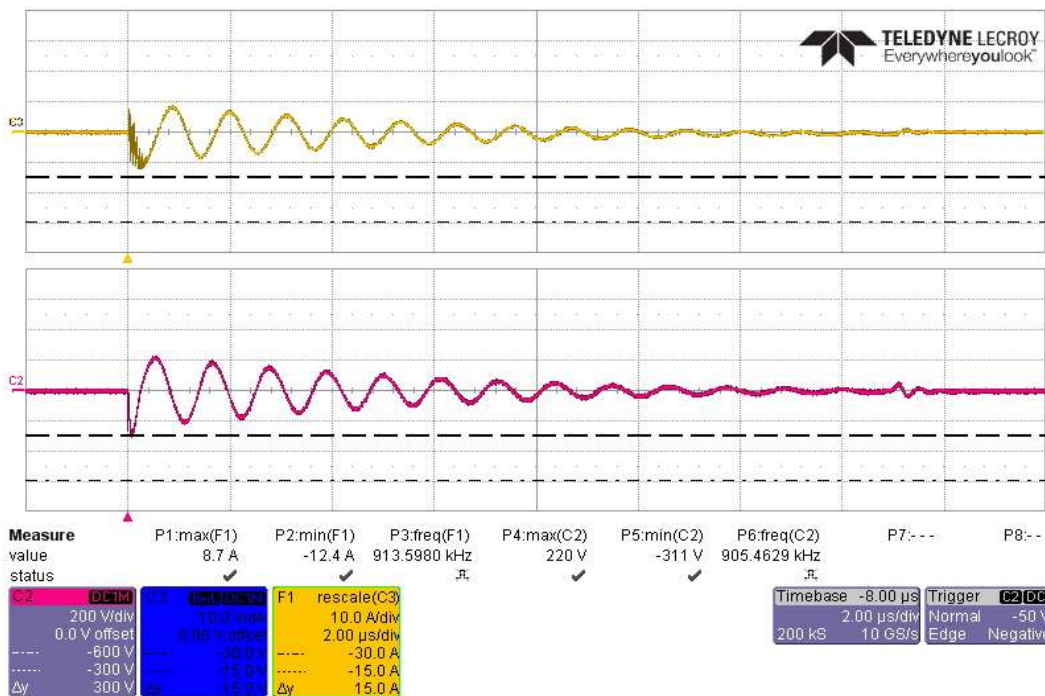

Actual Test CS117 MS Waveform #3 at 1MHz, Subsequent Transient -300V, on Battery Return Side

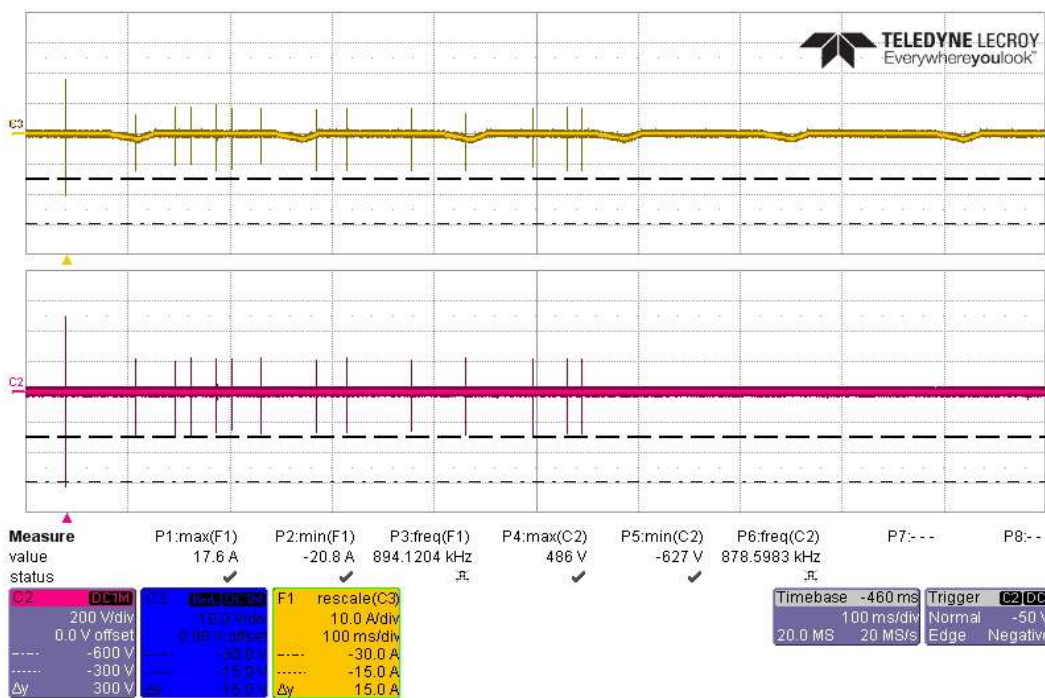

Actual Test CS117 MS Waveform #3 at 1MHz, 14 Transients -600/-300V, on Battery Return Side

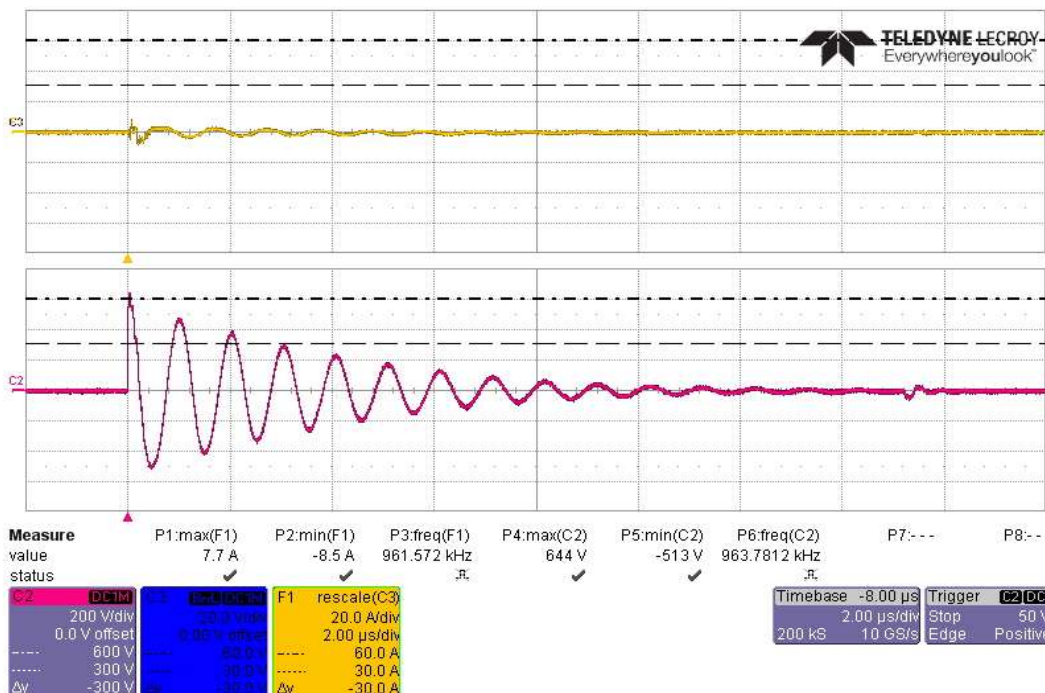

Actual Test CS117 MS Waveform #3 at 1MHz, First Transient +600V, on Battery Bundle

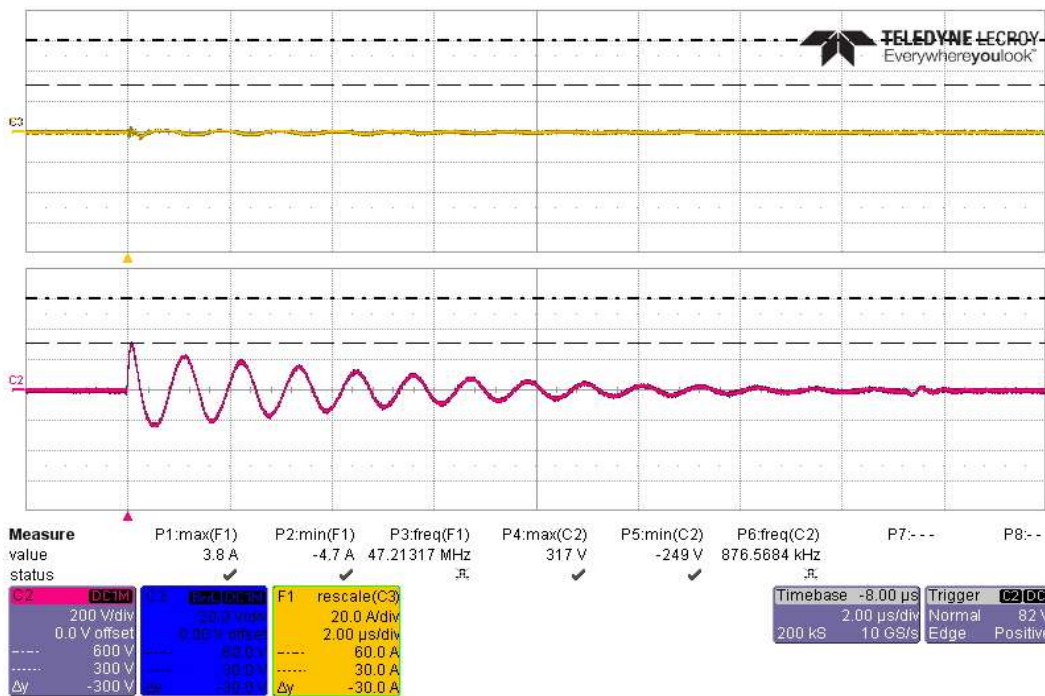

Actual Test CS117 MS Waveform #3 at 1MHz, Subsequent Transient +300V, on Battery Bundle

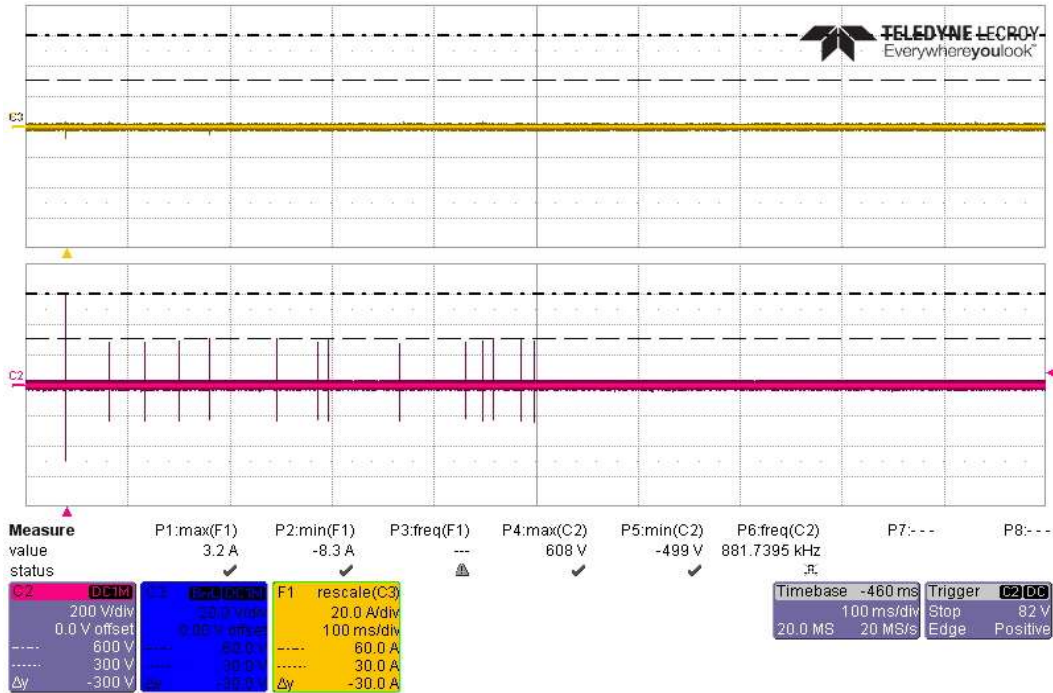

Actual Test CS117 MS Waveform #3 at 1MHz, 14 Transients +600/+300V, on Battery Bundle

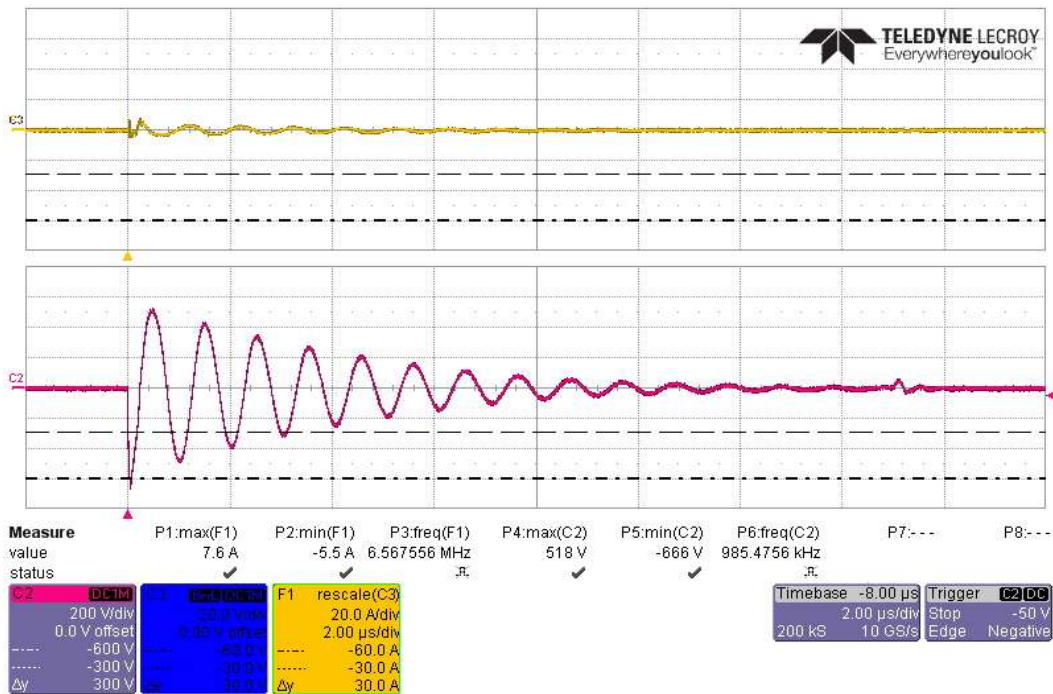

Actual Test CS117 MS Waveform #3 at 1MHz, First Transient -600V, on Battery Bundle

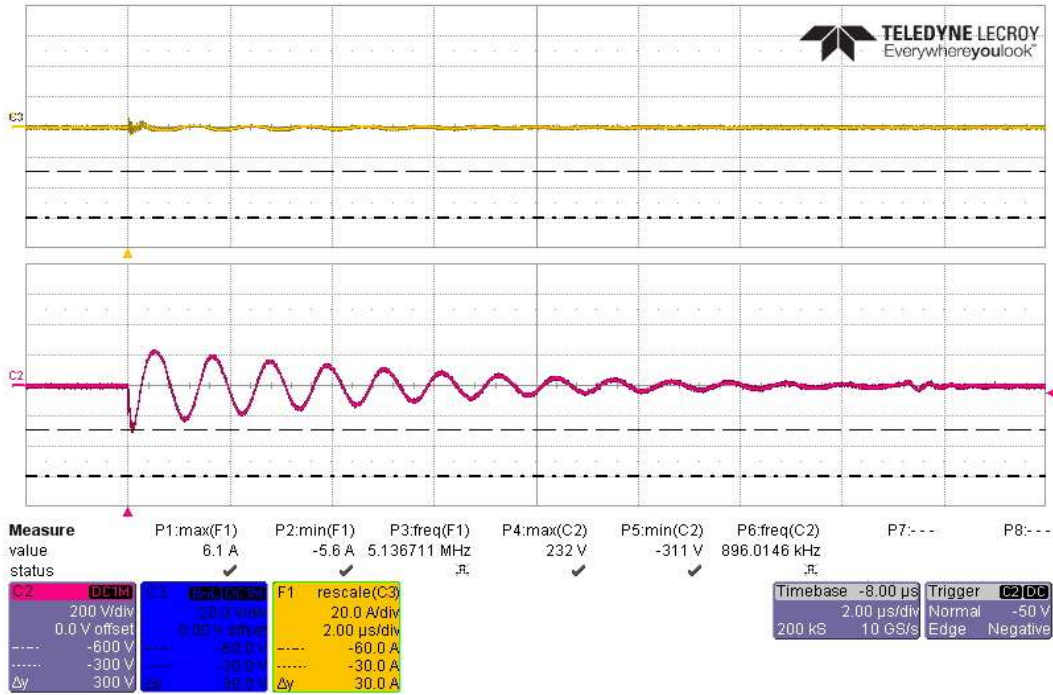

Actual Test CS117 MS Waveform #3 at 1MHz, Subsequent Transient -300V, on Battery Bundle

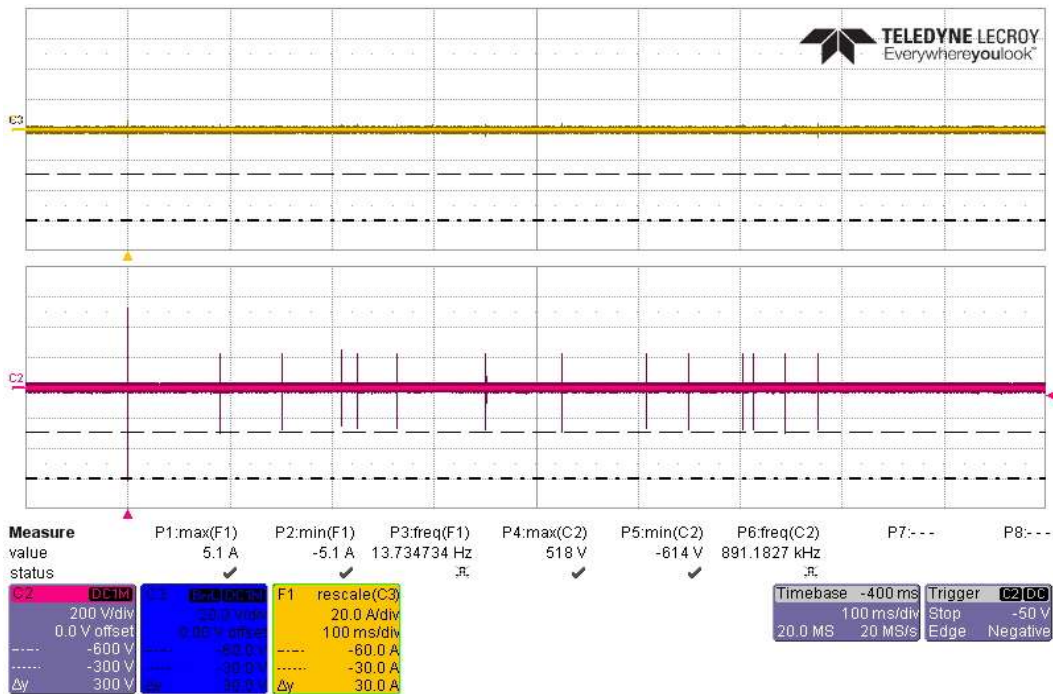

Actual Test CS117 MS Waveform #3 at 1MHz, 14 Transients -600/-300V, on Battery Bundle

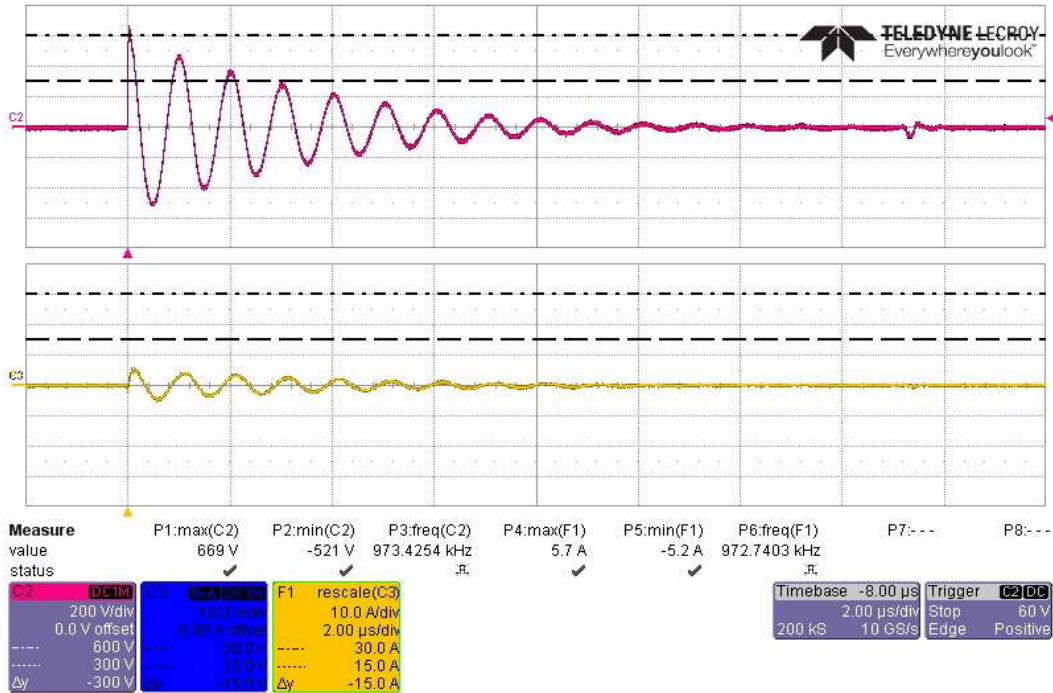

Actual Test CS117 MS Waveform #3 at 1MHz, First Transient +600V, on PV High Side

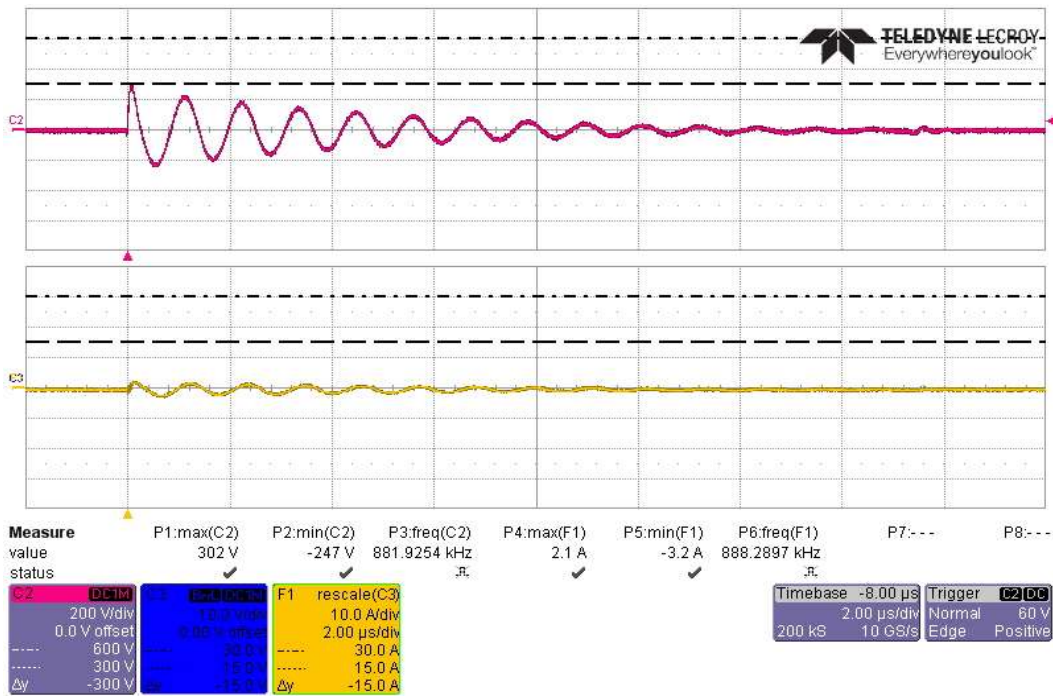

Actual Test CS117 MS Waveform #3 at 1MHz, Subsequent Transient +300V, on PV High Side

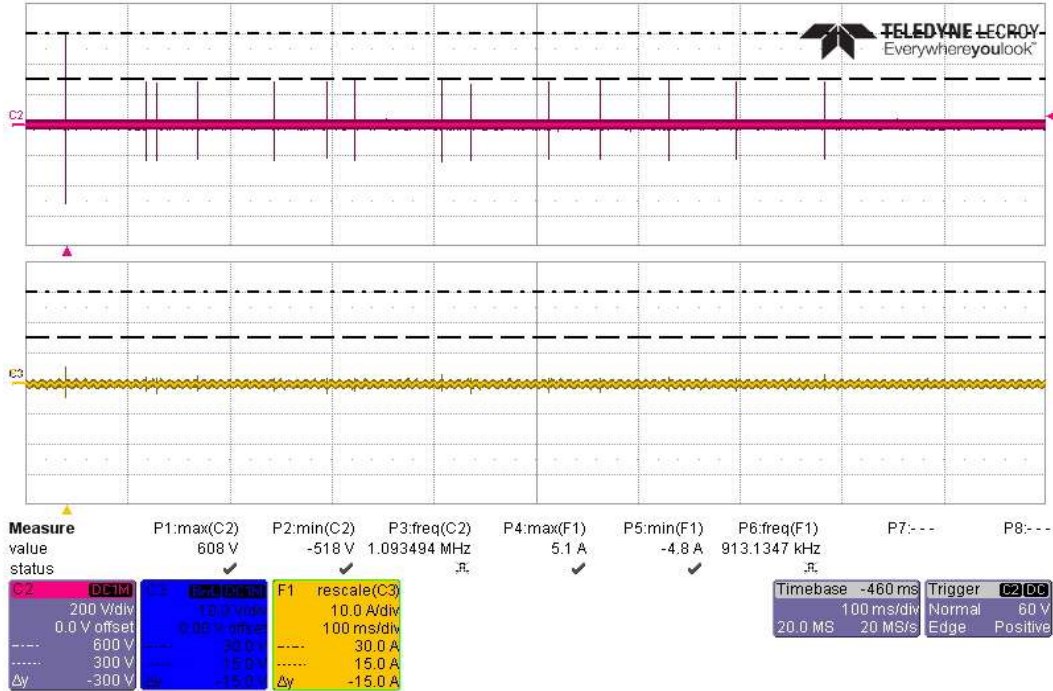

Actual Test CS117 MS Waveform #3 at 1MHz, 14 Transients +600/+300V, on PV High Side

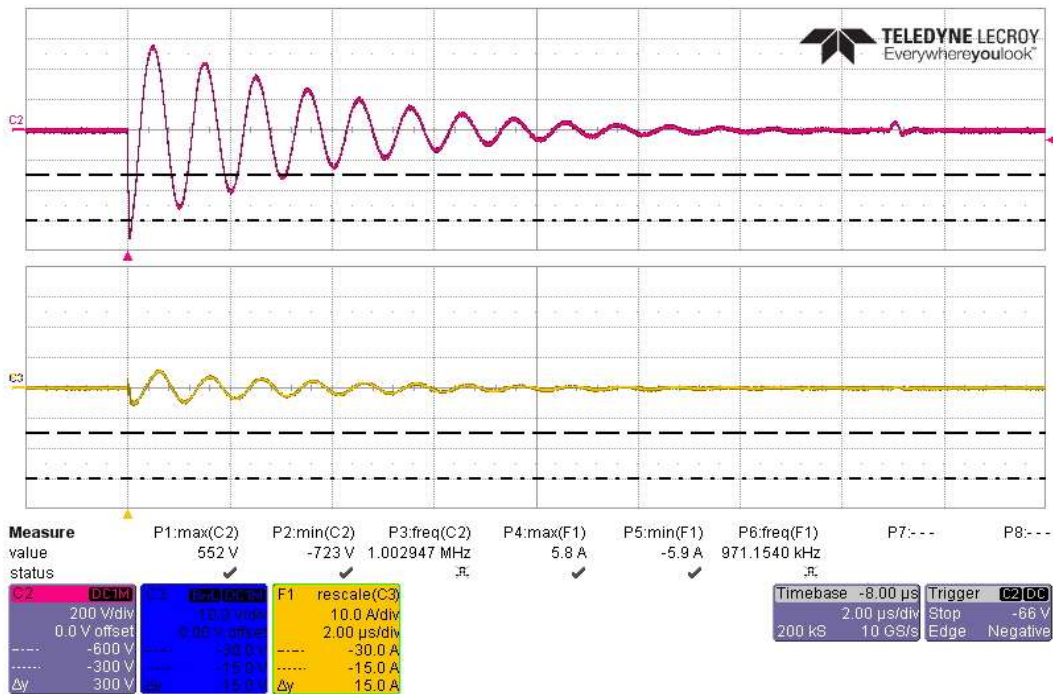

Actual Test CS117 MS Waveform #3 at 1MHz, First Transient -600V, on PV High Side

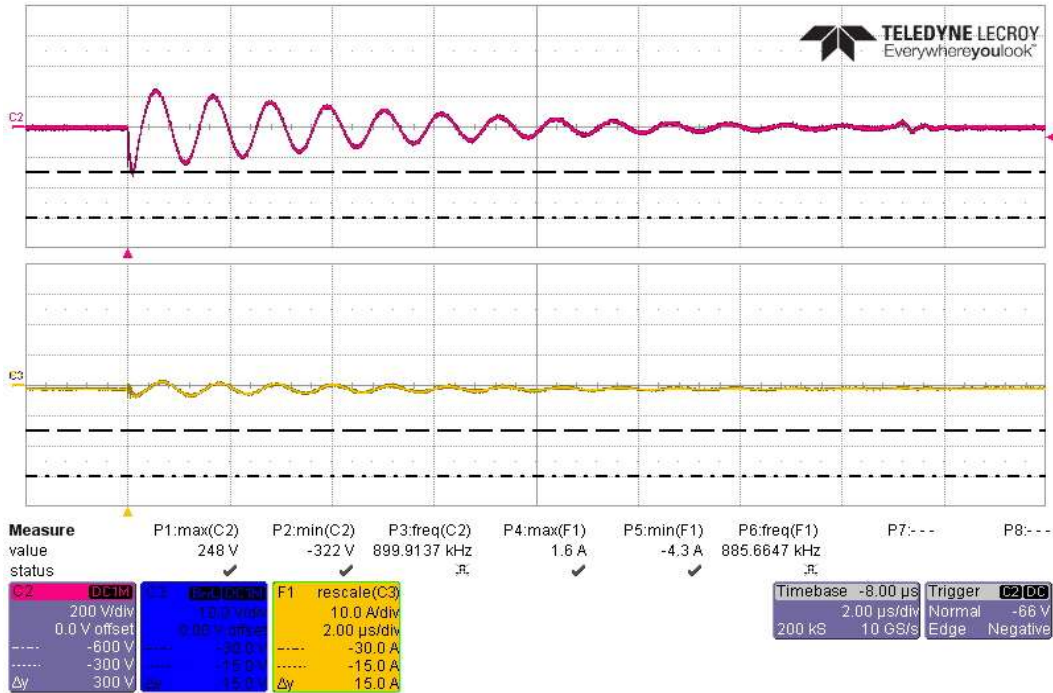

Actual Test CS117 MS Waveform #3 at 1MHz, Subsequent Transient -300V, on PV High Side

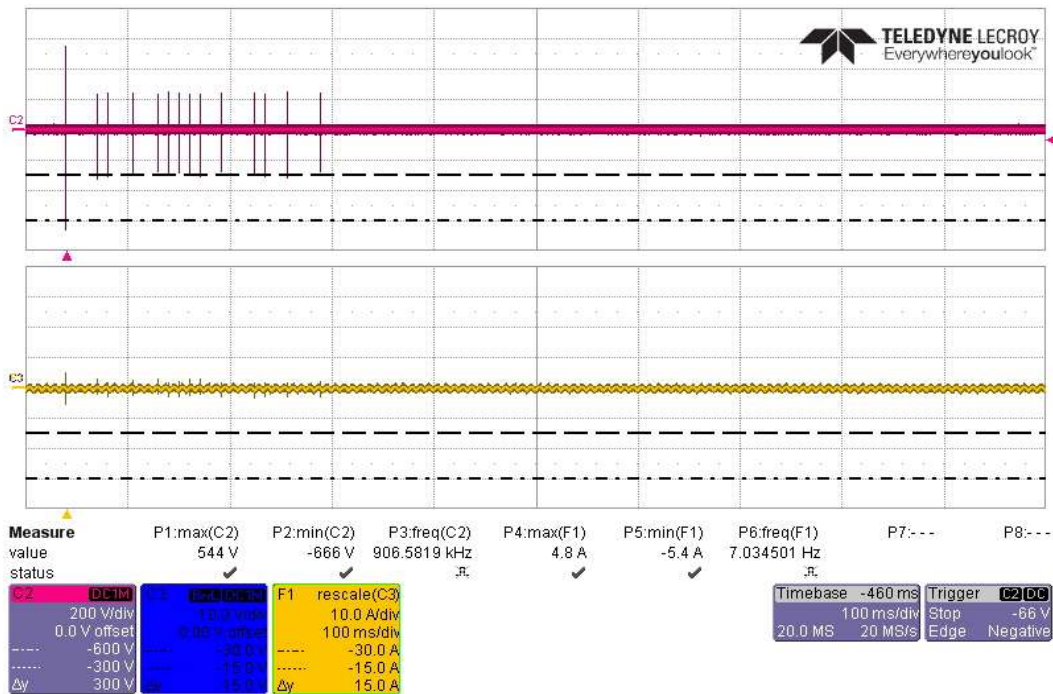

Actual Test CS117 MS Waveform #3 at 1MHz, 14 Transients -600/-300V, on PV High Side

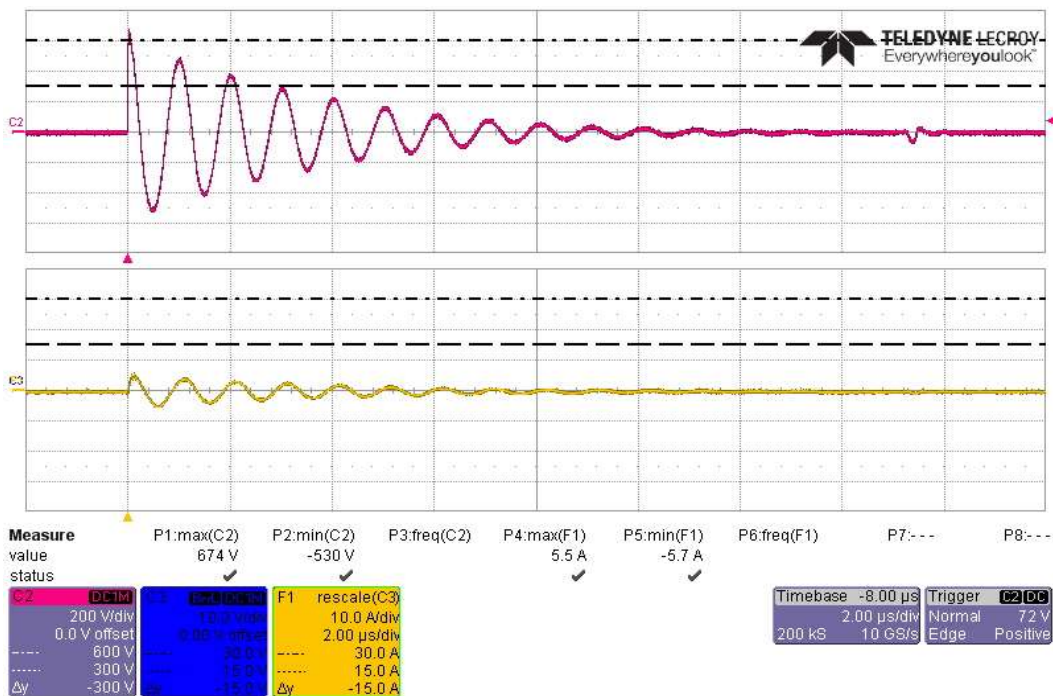

Actual Test CS117 MS Waveform #3 at 1MHz, First Transient +600V, on PV Return Side

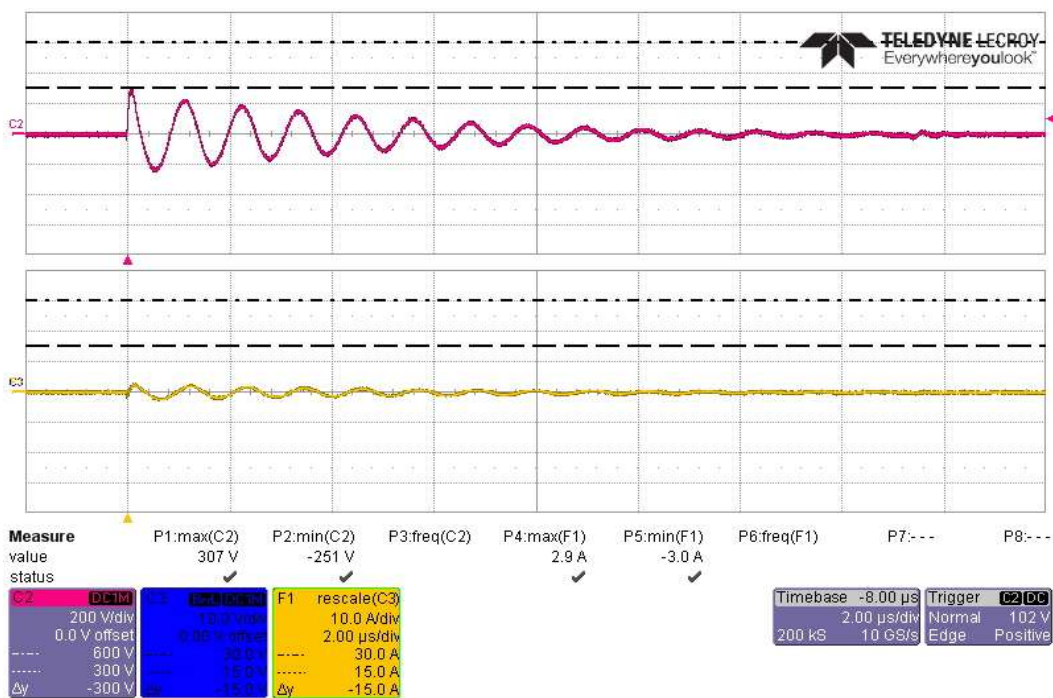

Actual Test CS117 MS Waveform #3 at 1MHz, Subsequent Transient +300V, on PV Return Side

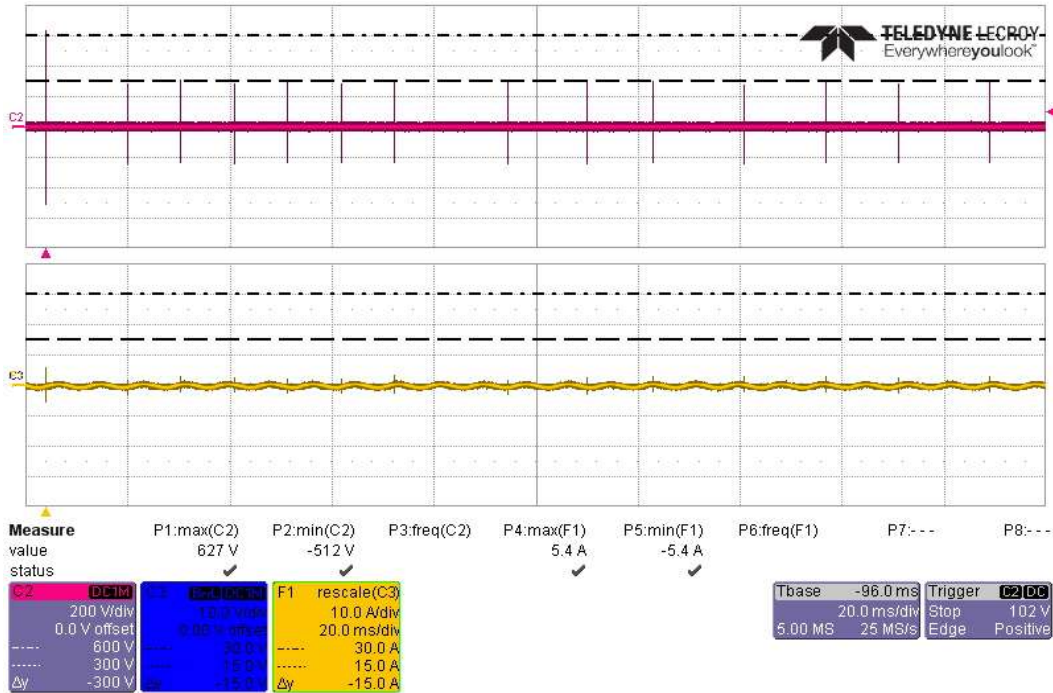

Actual Test CS117 MS Waveform #3 at 1MHz, 14 Transients +600/+300V, on PV Return Side

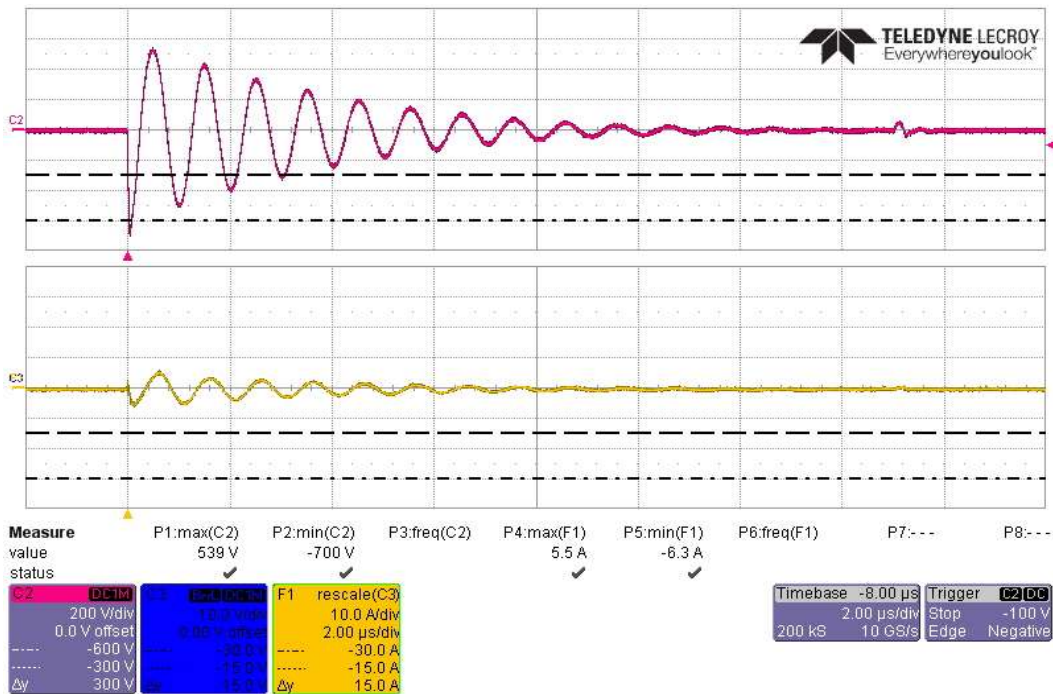

Actual Test CS117 MS Waveform #3 at 1MHz, First Transient -600V, on PV Return Side

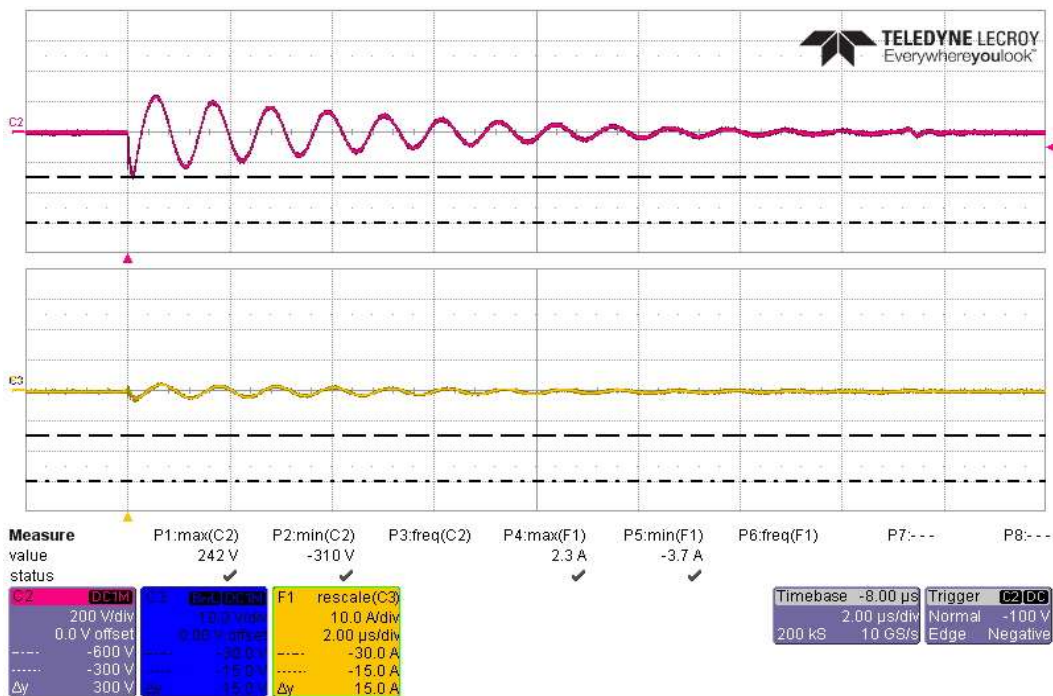

Actual Test CS117 MS Waveform #3 at 1MHz, Subsequent Transient -300V, on PV Return Side

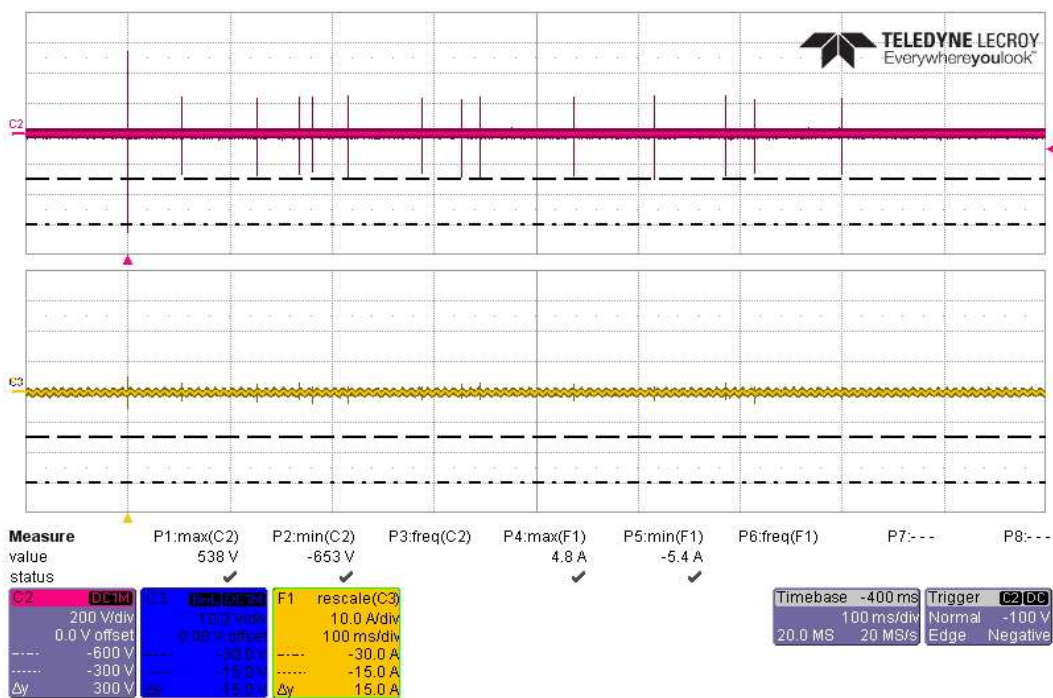

Actual Test CS117 MS Waveform #3 at 1MHz, 14 Transients -600/-300V, on PV Return Side

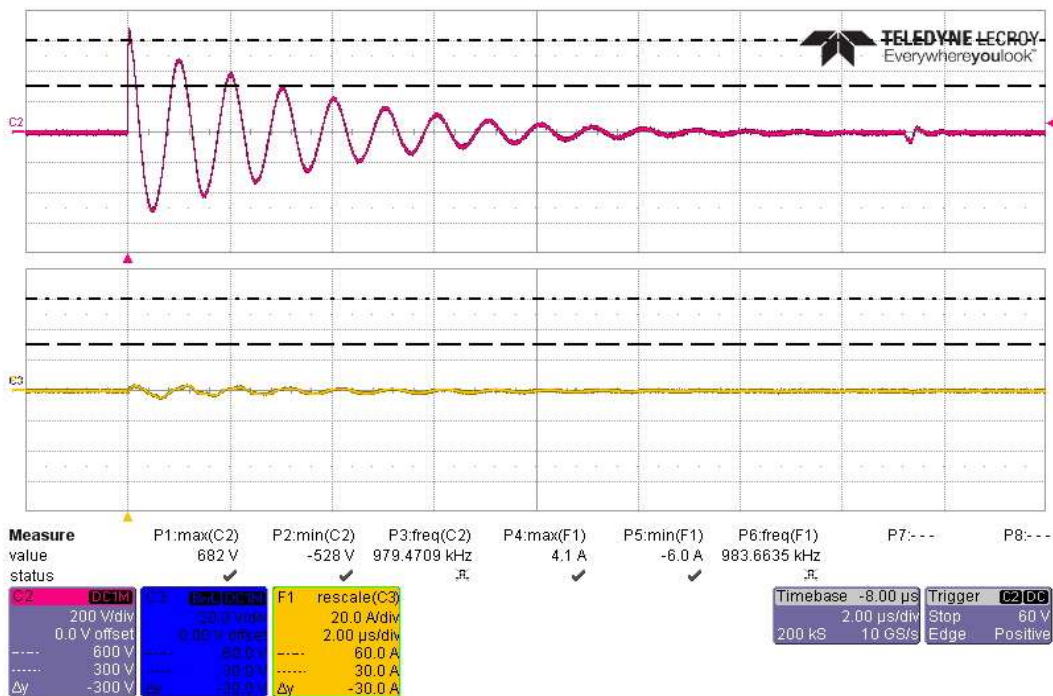

Actual Test CS117 MS Waveform #3 at 1MHz, First Transient +600V, on PV Bundle

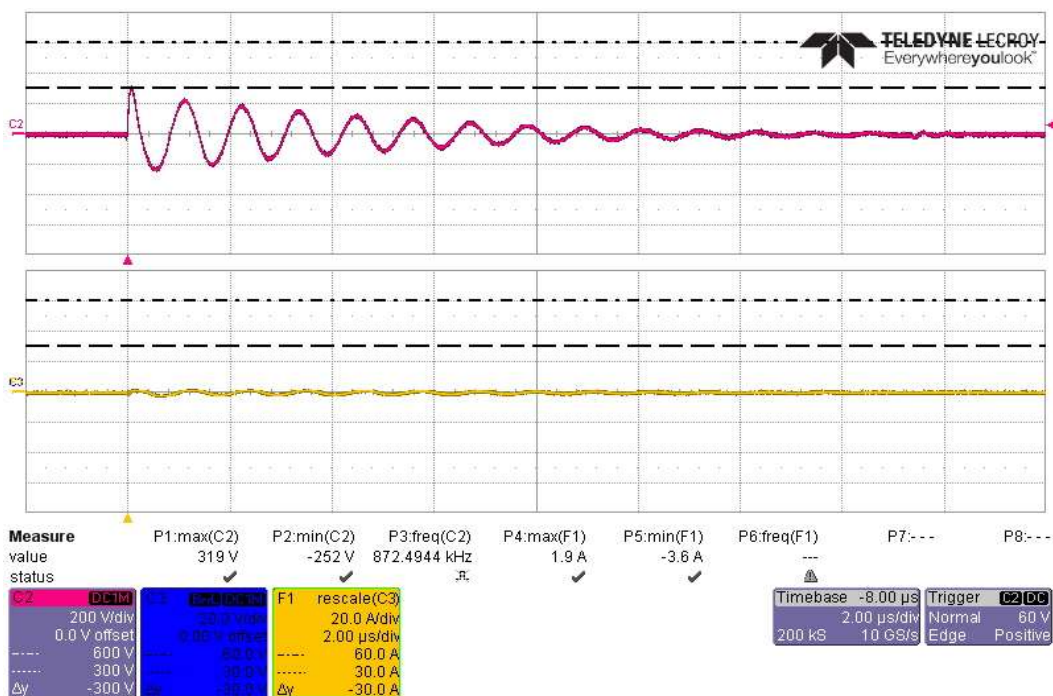

Actual Test CS117 MS Waveform #3 at 1MHz, Subsequent Transient +300V, on PV Bundle

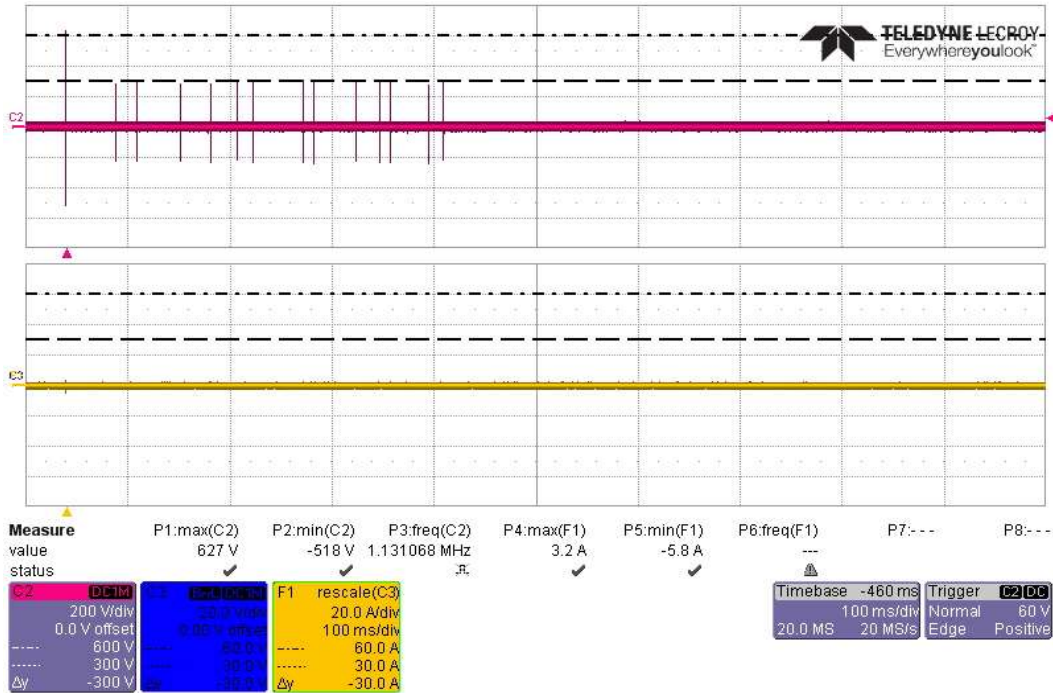

Actual Test CS117 MS Waveform #3 at 1MHz, 14 Transients +600/+300V, on PV Bundle

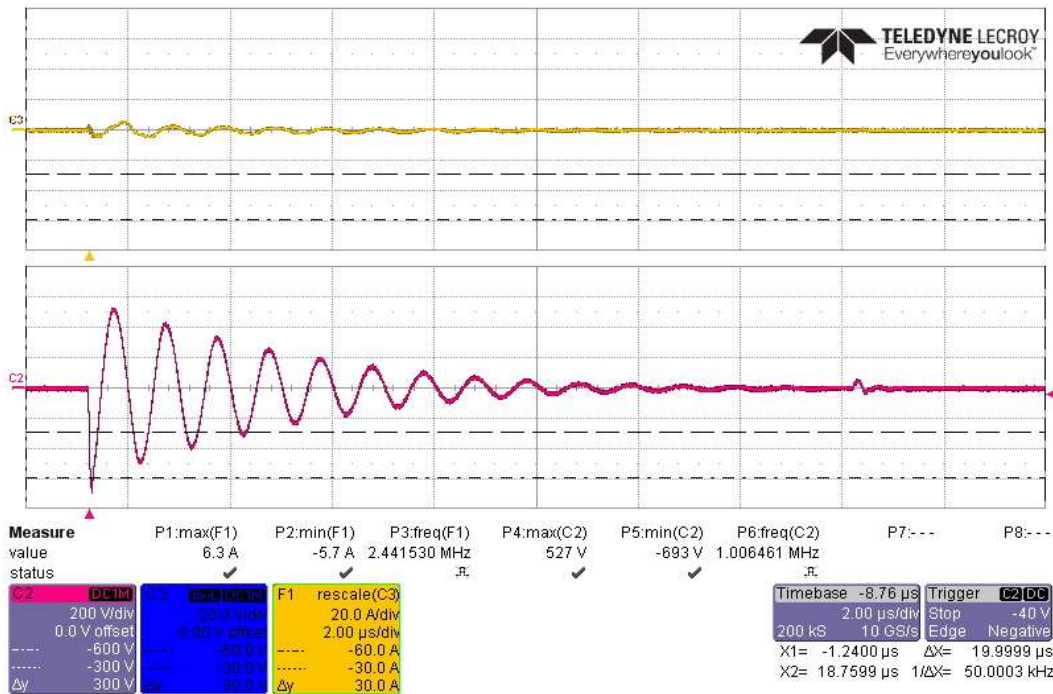

Actual Test CS117 MS Waveform #3 at 1MHz, First Transient -600V, on PV Bundle

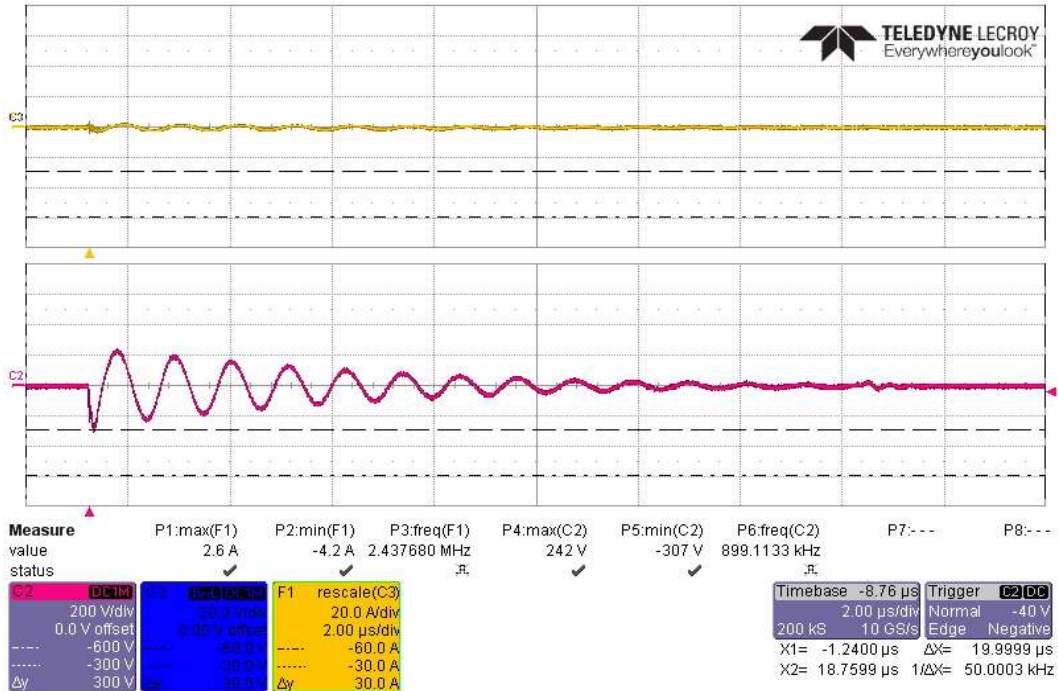

Actual Test CS117 MS Waveform #3 at 1MHz, Subsequent Transient -300V, on PV Bundle

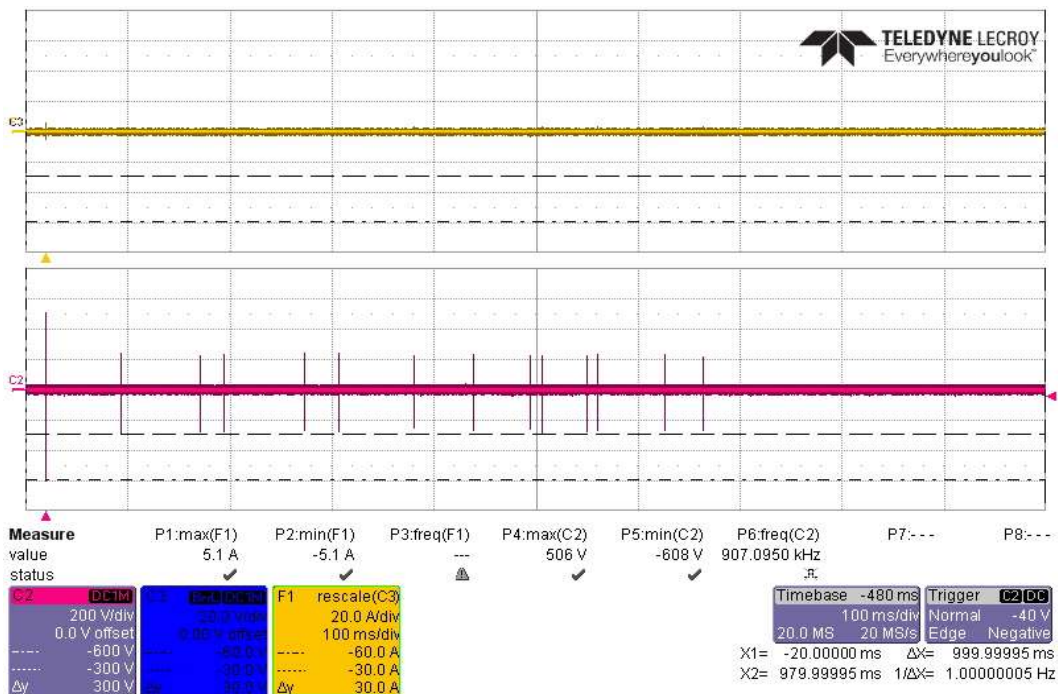

Actual Test CS117 MS Waveform #3 at 1MHz, 14 Transients -600/-300V, on PV Bundle

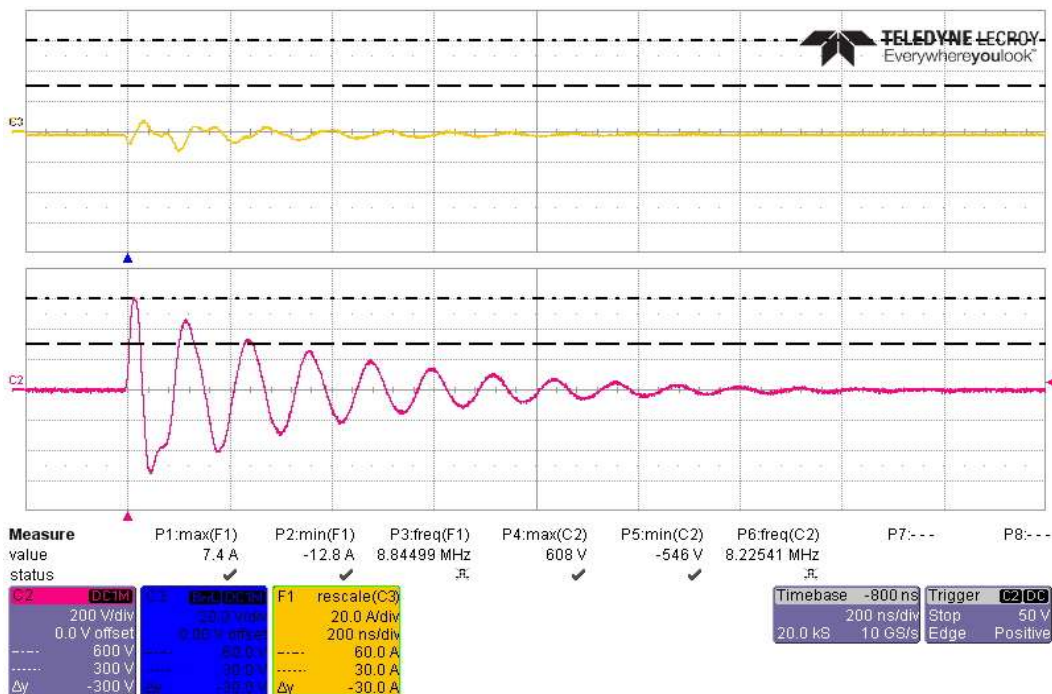
CS117 Actual MS Test Waveform #3 at 10MHz with 600V/24A

Actual Test CS117 Waveform #3 at 10MHz, First Transient +600V, on Power Line 1

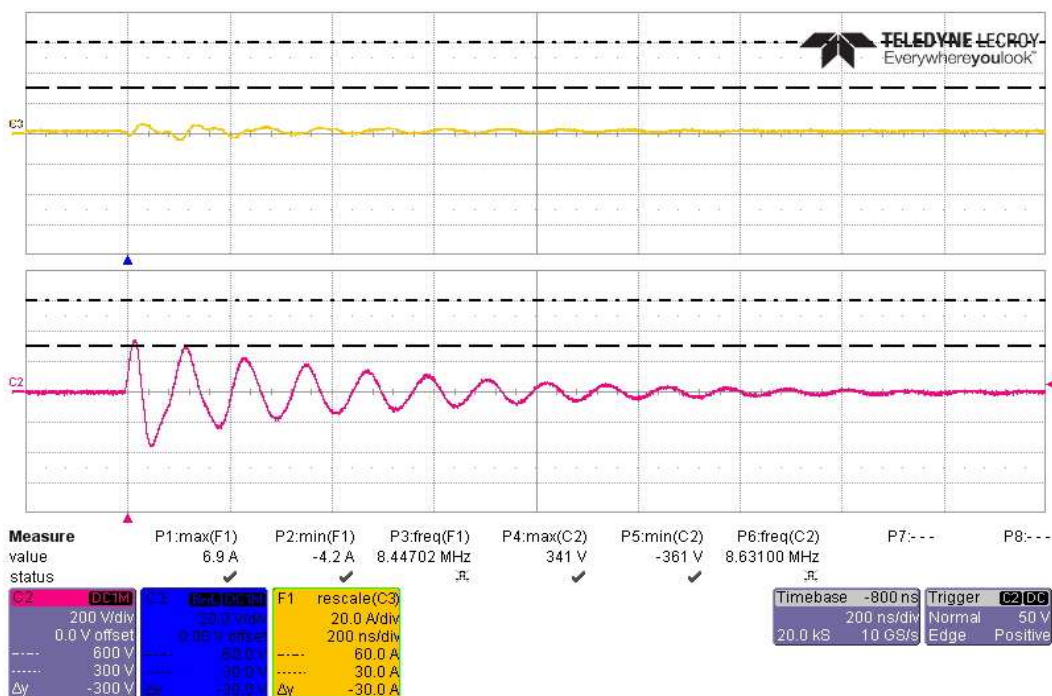

Actual Test CS117 Waveform #3 at 10MHz, Subsequent Transient +300V, on Power Line 1

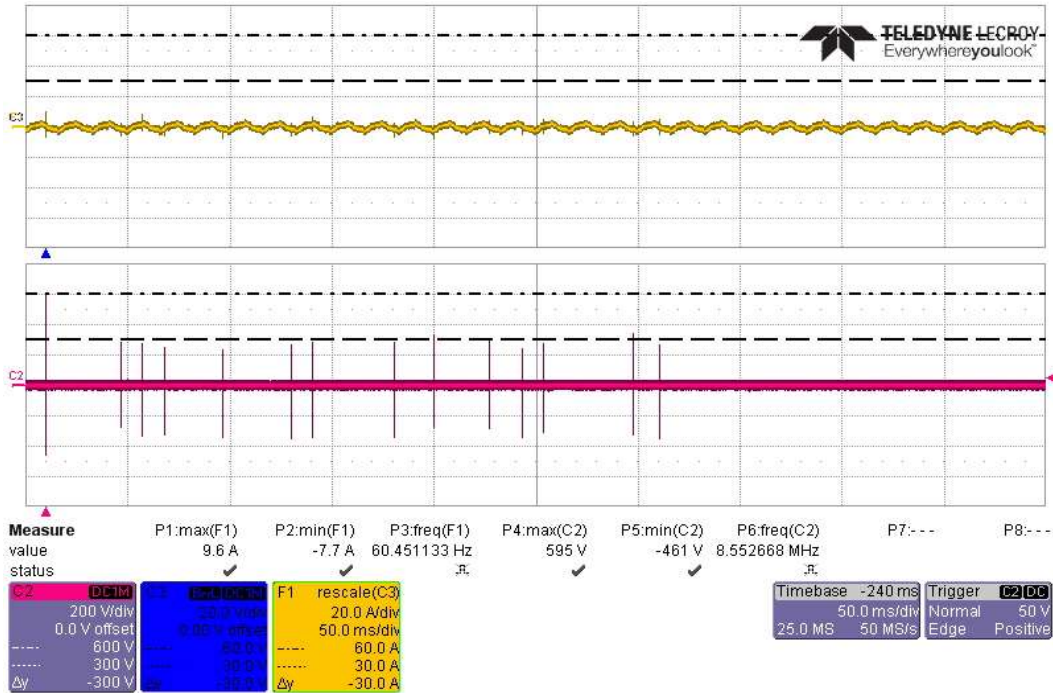

Actual Test CS117 Waveform #3 at 10MHz, 14 Transients +600/+300V, on Power Line 1

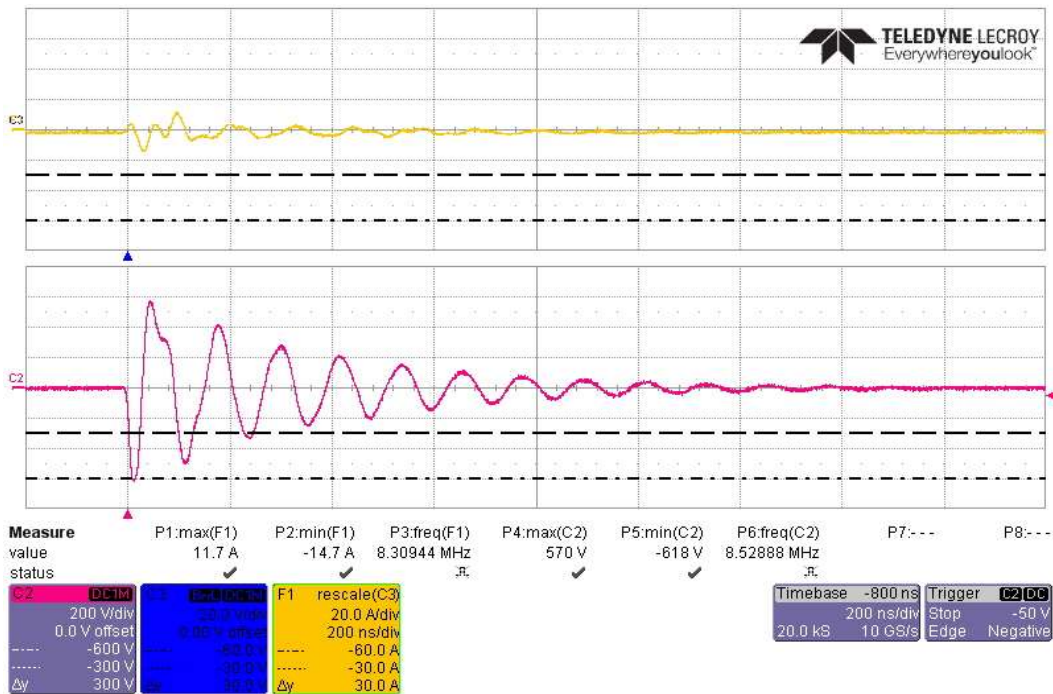

Actual Test CS117 Waveform #3 at 10MHz, First Transient -600V, on Power Line 1

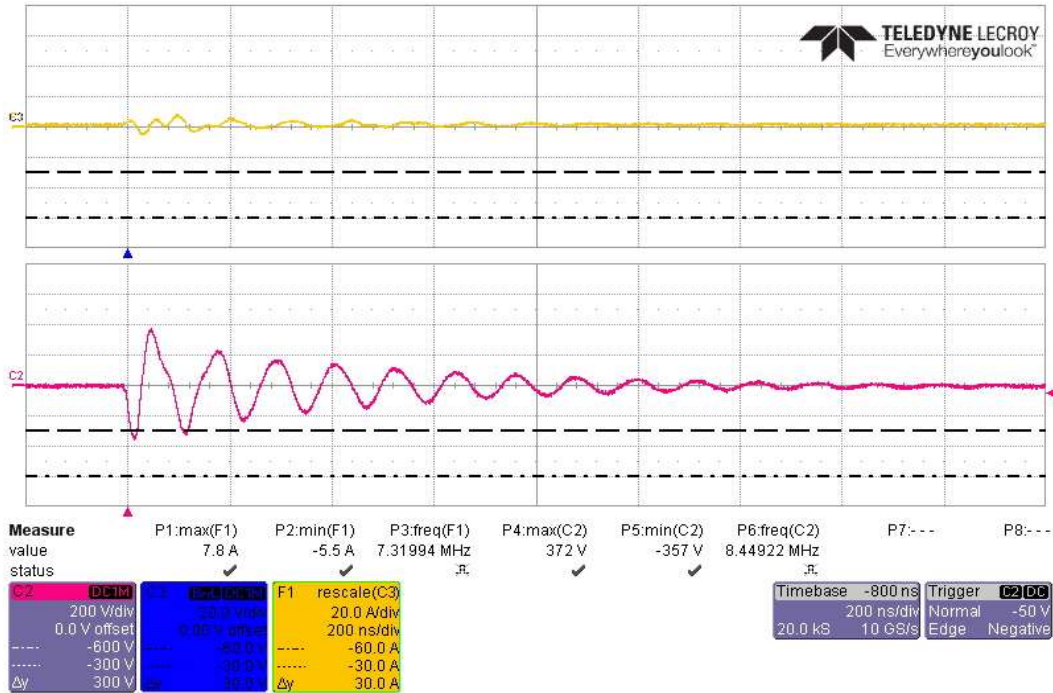

Actual Test CS117 Waveform #3 at 10MHz, Subsequent Transient -300V, on Power Line 1

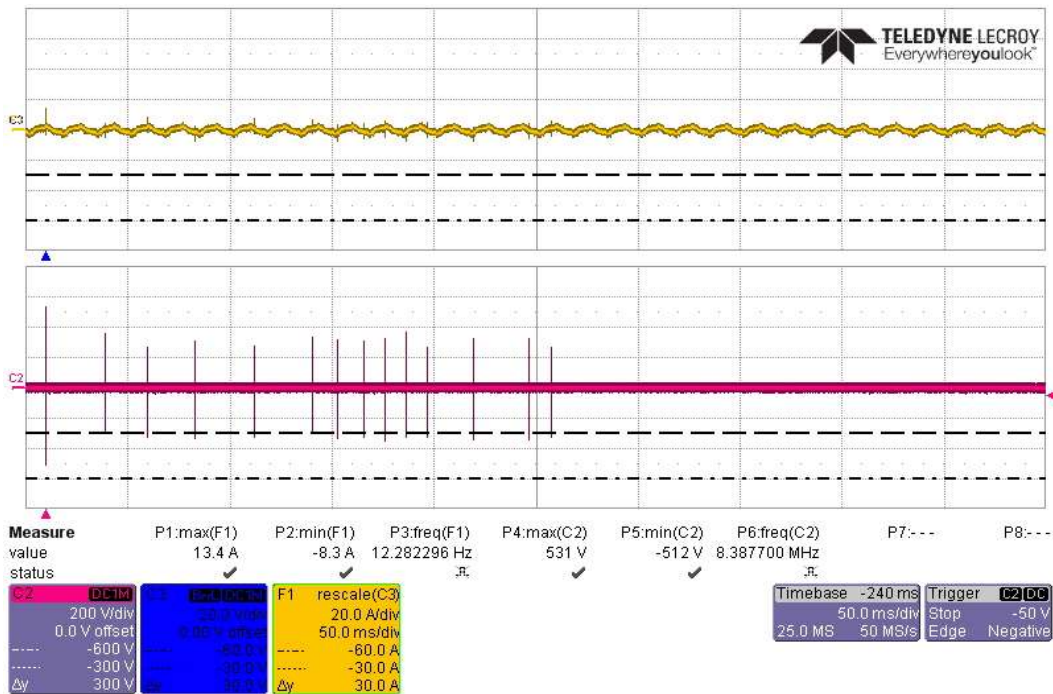

Actual Test CS117 Waveform #3 at 10MHz, 14 Transients -600/-300V, on Power Line 1

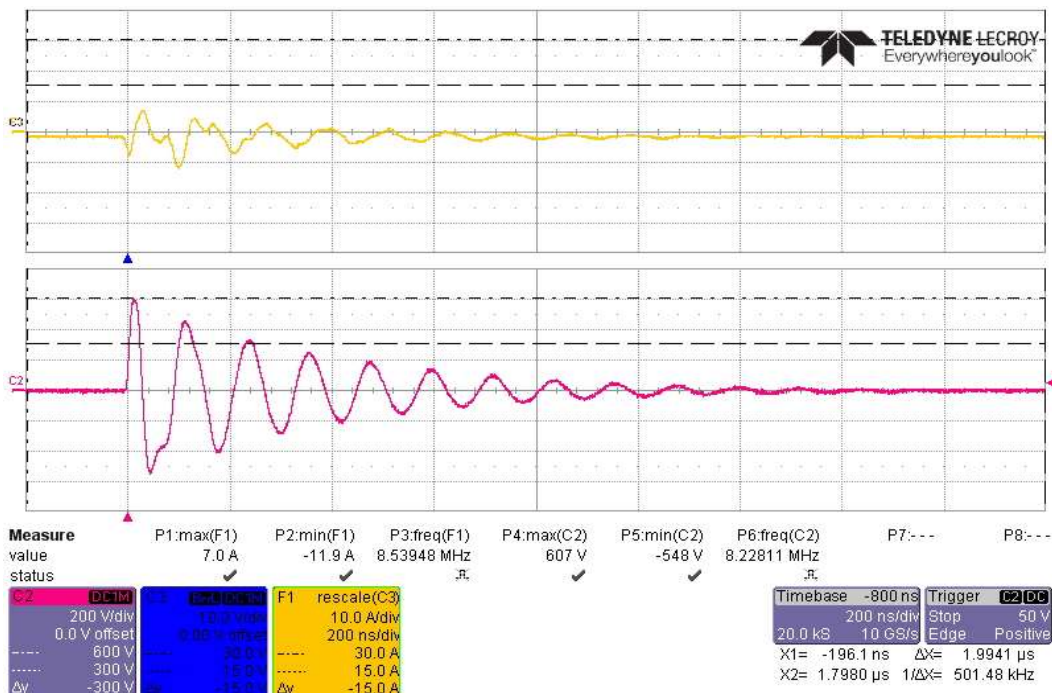

Actual Test CS117 Waveform #3 at 10MHz, First Transient +600V, on Power Line 2

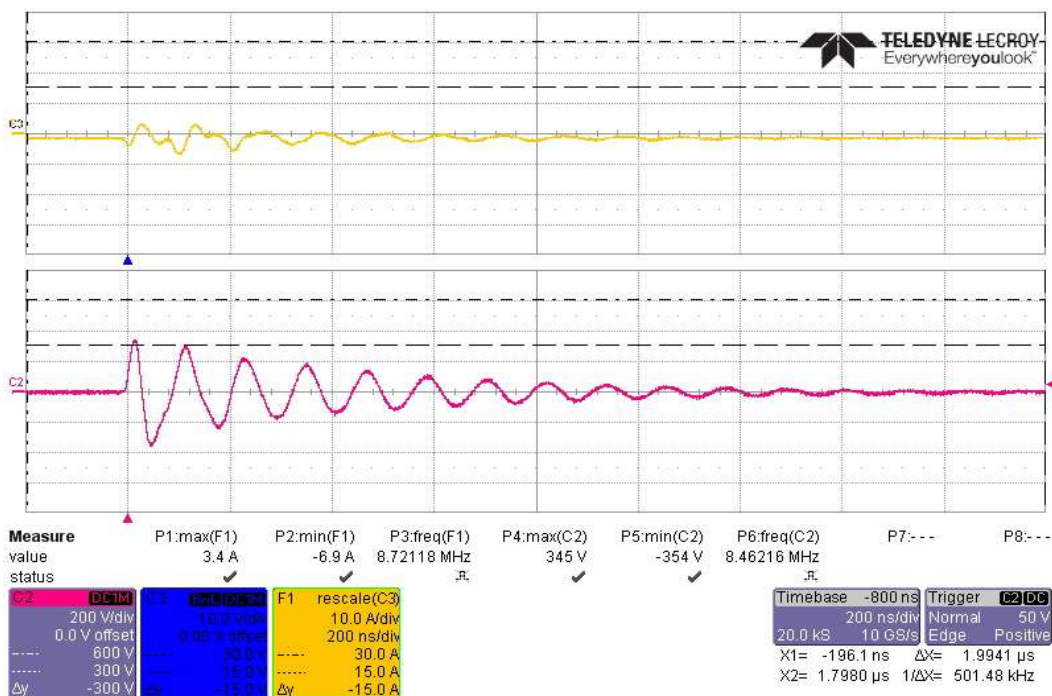

Actual Test CS117 Waveform #3 at 10MHz, Subsequent Transient +300V, on Power Line 2

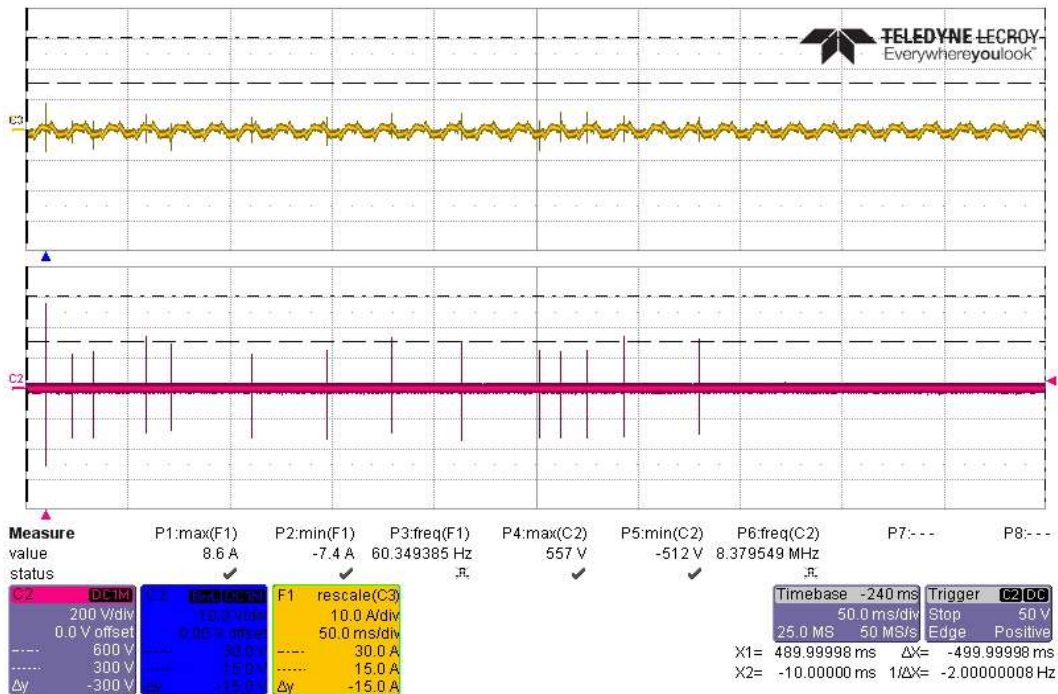

Actual Test CS117 Waveform #3 at 10MHz, 14 Transients +600/+300V, on Power Line 2

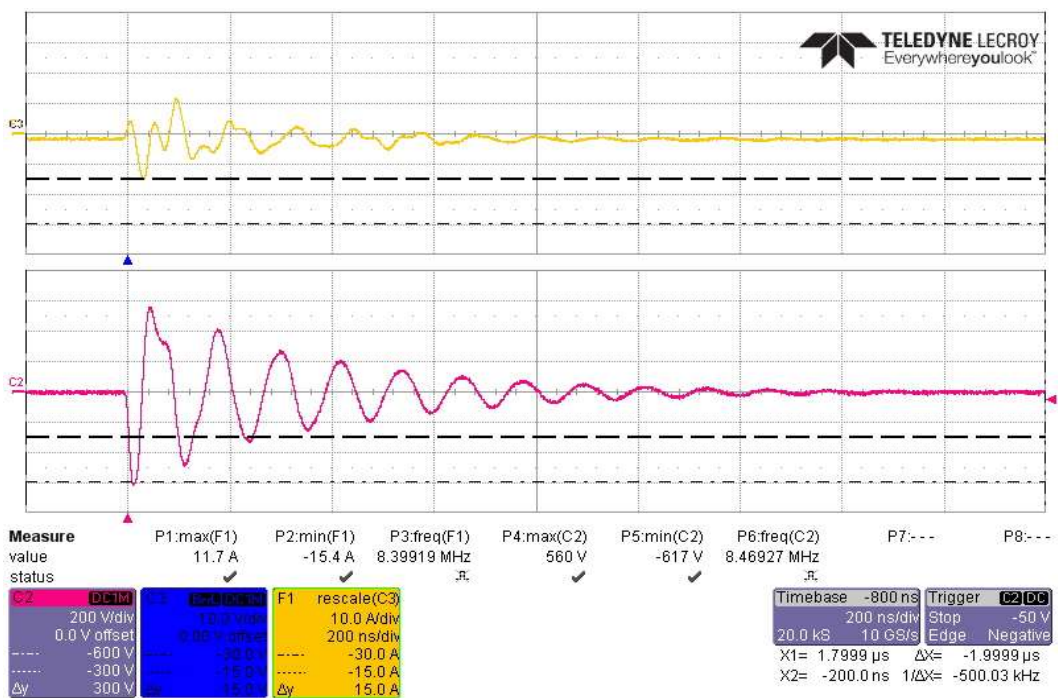

Actual Test CS117 Waveform #3 at 10MHz, First Transient -600V, on Power Line 2

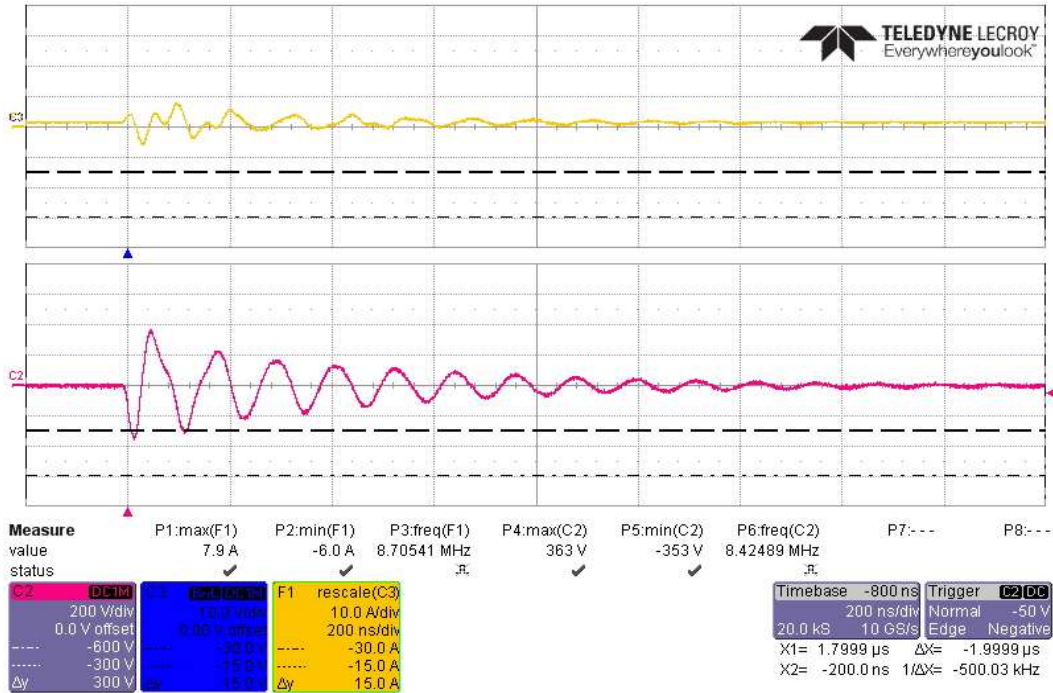

Actual Test CS117 Waveform #3 at 10MHz, Subsequent Transient -300V, on Power Line 2

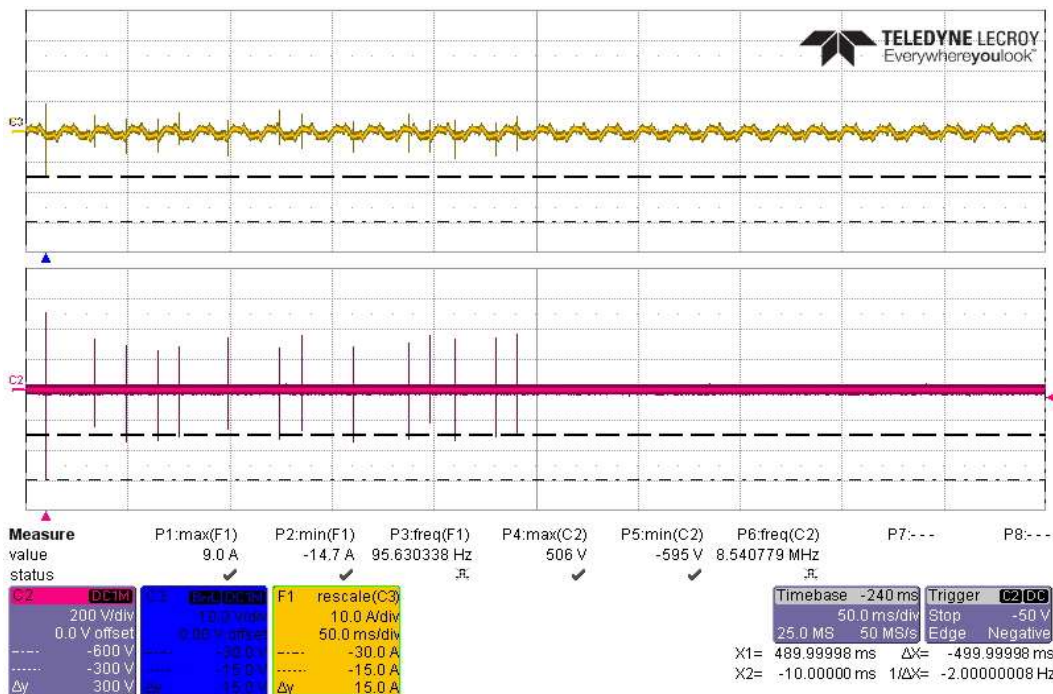

Actual Test CS117 Waveform #3 at 10MHz, 14 Transients -600/-300V, on Power Line 2

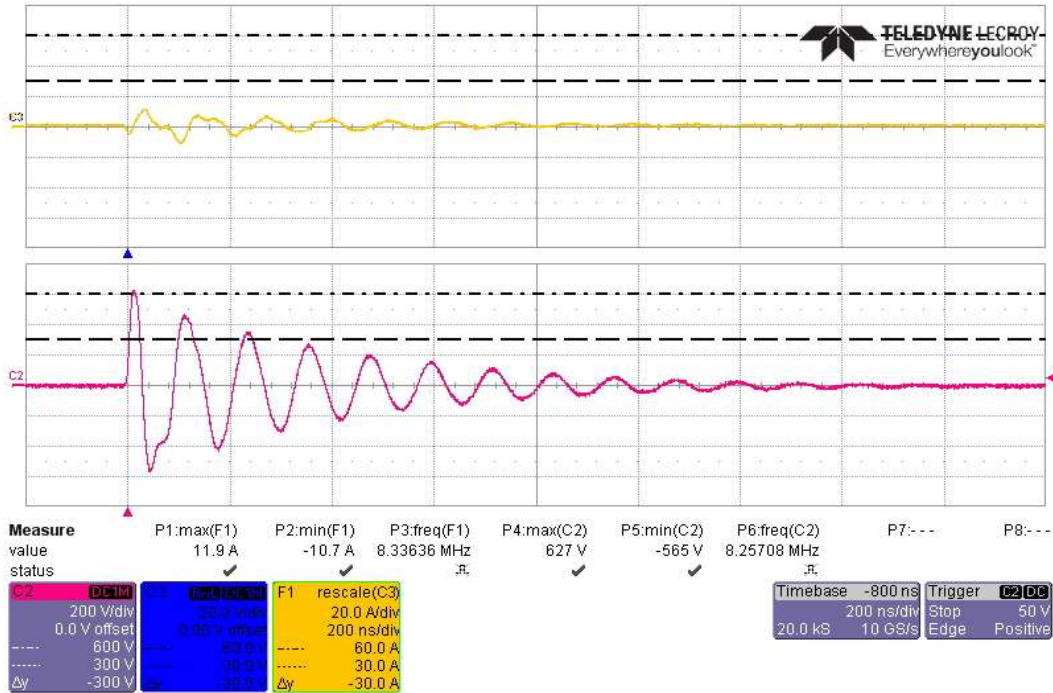

Actual Test CS117 Waveform #3 at 10MHz, First Transient +600V, on Power Lines

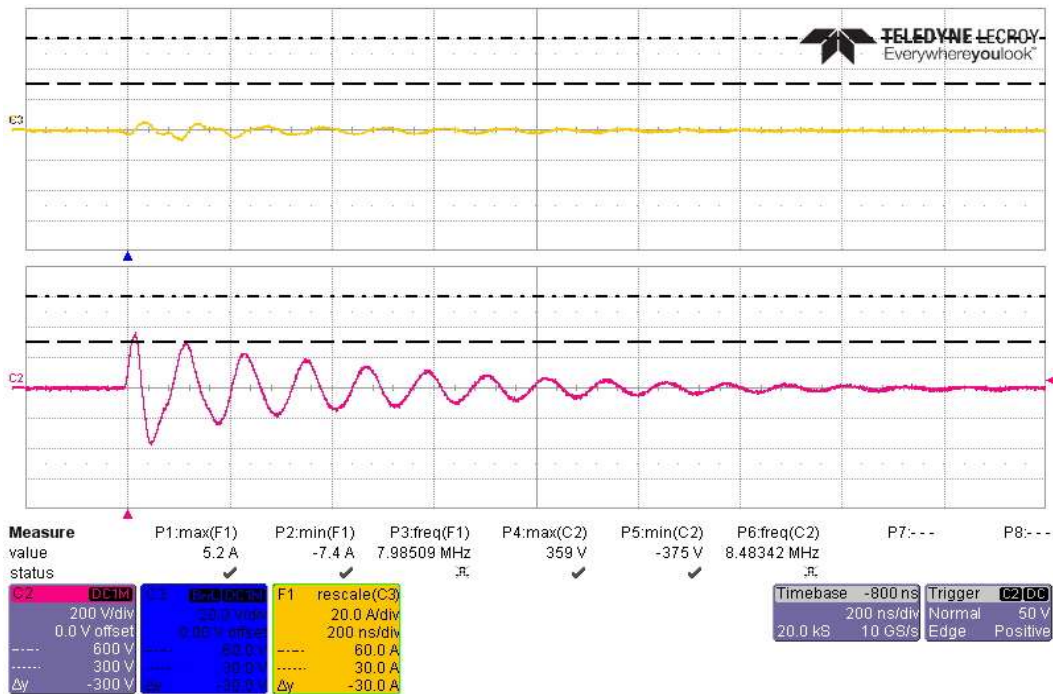

Actual Test CS117 Waveform #3 at 10MHz, Subsequent Transient +300V, on Power Lines

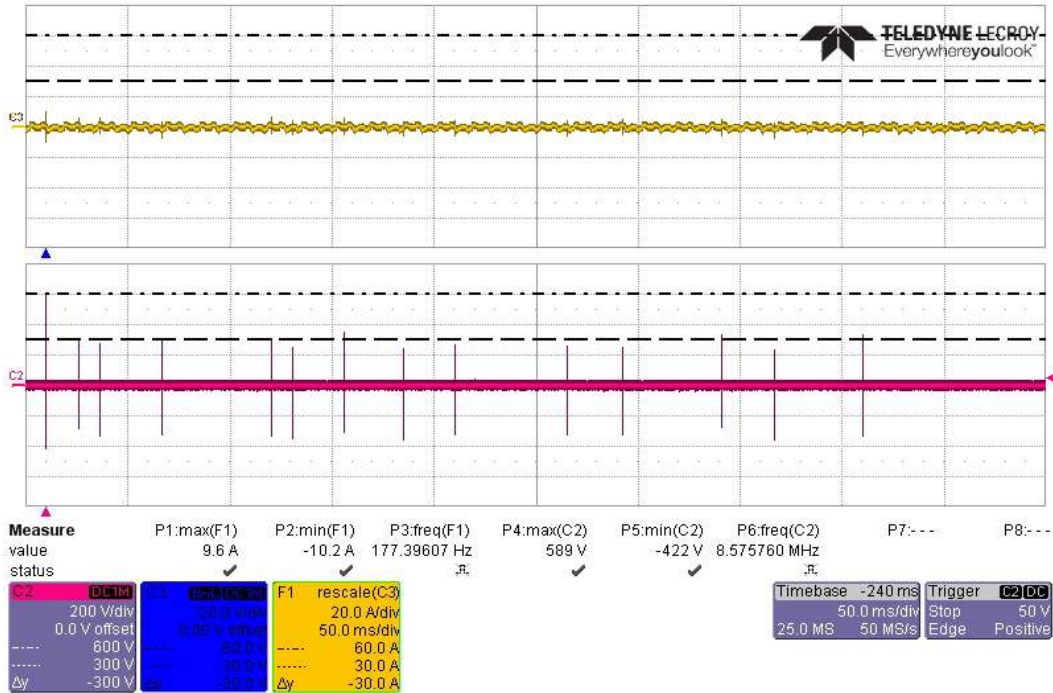

Actual Test CS117 Waveform #3 at 10MHz, 14 Transients +600/+300V, on Power Lines

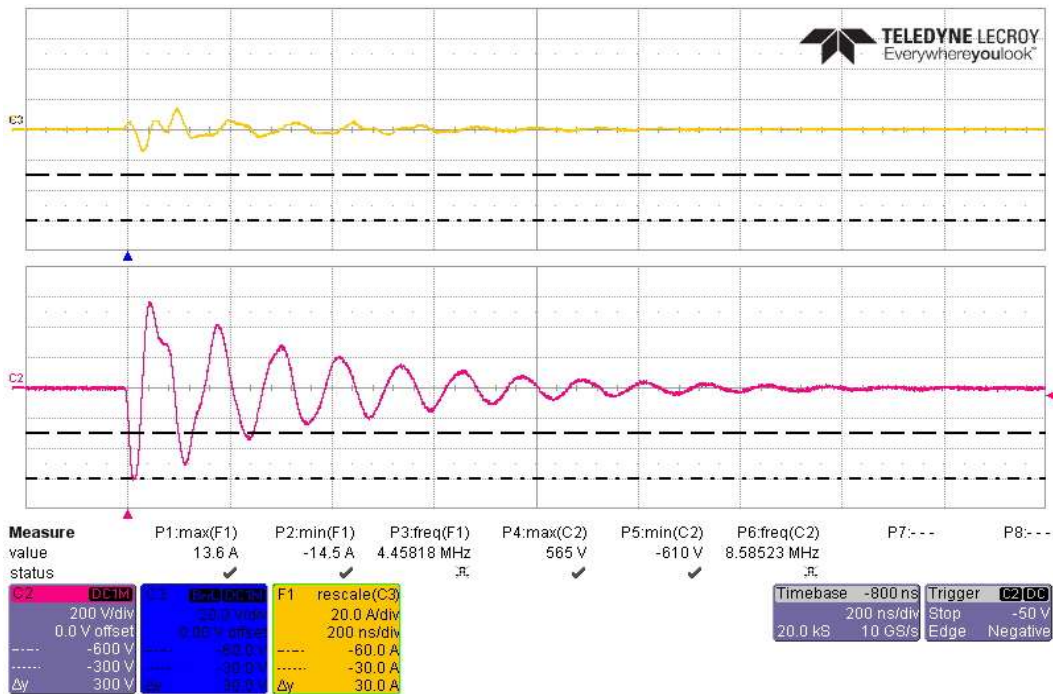

Actual Test CS117 Waveform #3 at 10MHz, First Transient -600V, on Power Lines

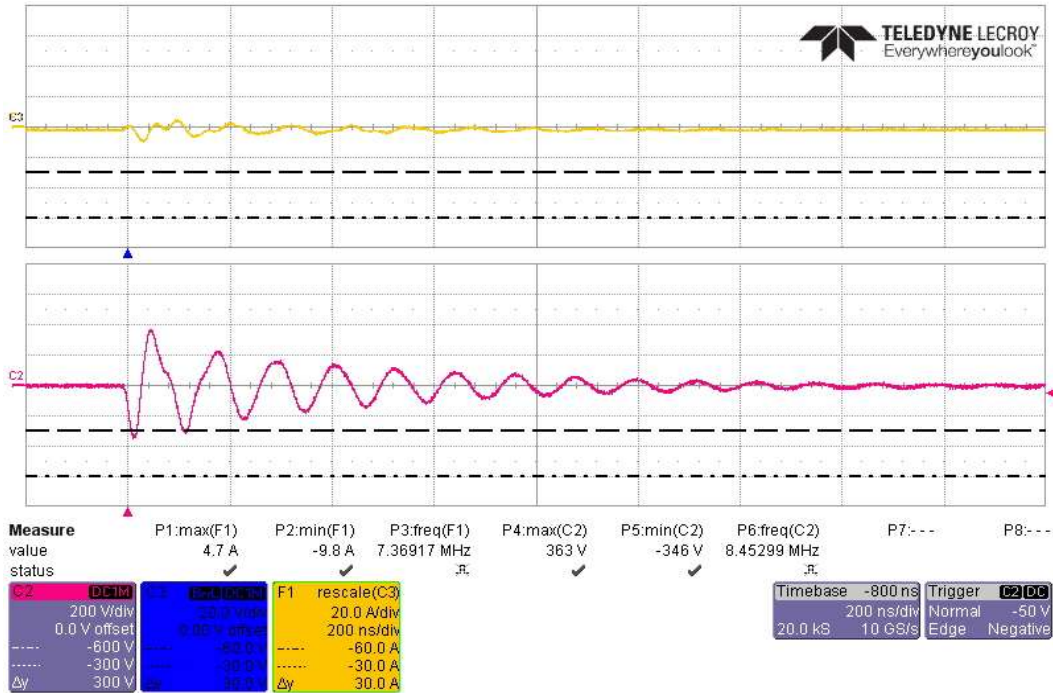

Actual Test CS117 Waveform #3 at 10MHz, Subsequent Transient -300V, on Power Lines

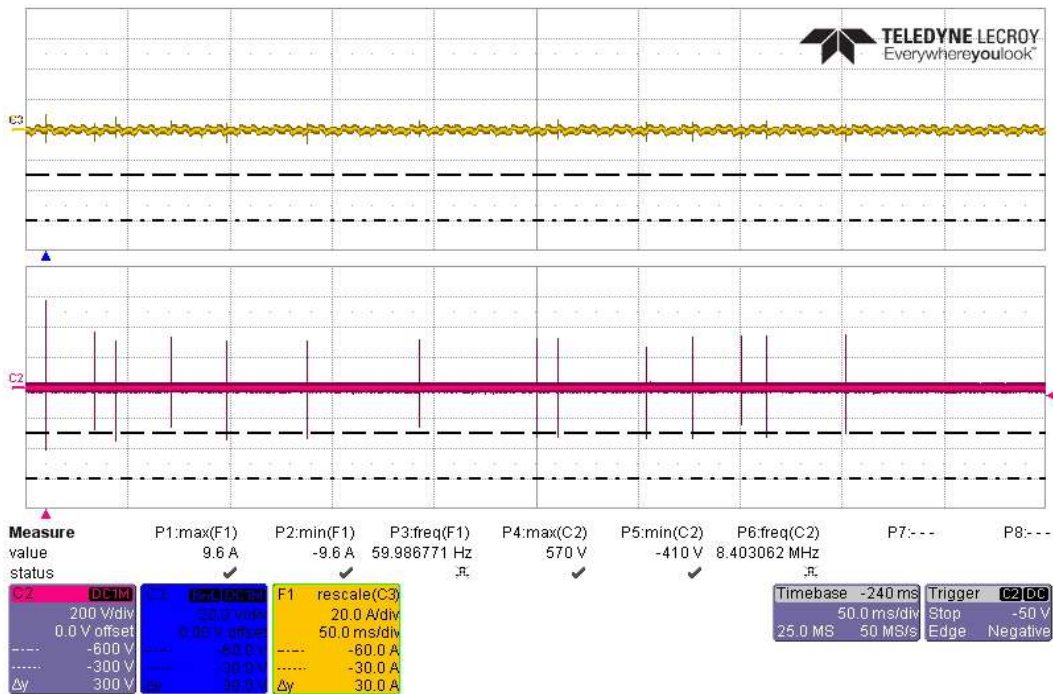

Actual Test CS117 Waveform #3 at 10MHz, 14 Transients -600/-300V, on Power Lines

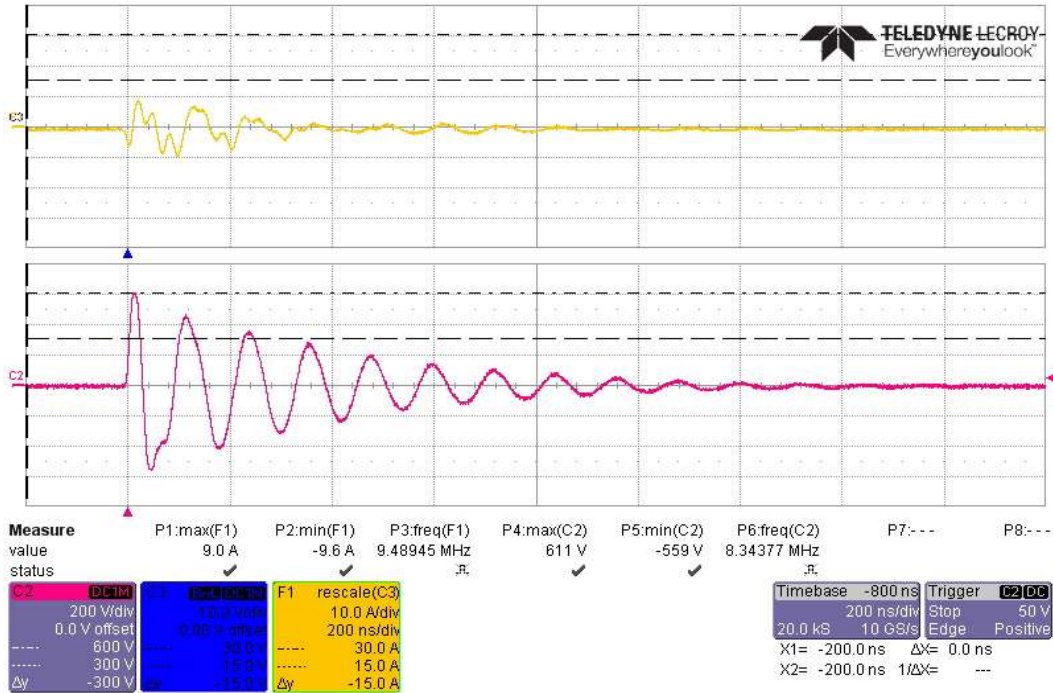

Actual Test CS117 Waveform #3 at 10MHz, First Transient +600V, on Battery High Side

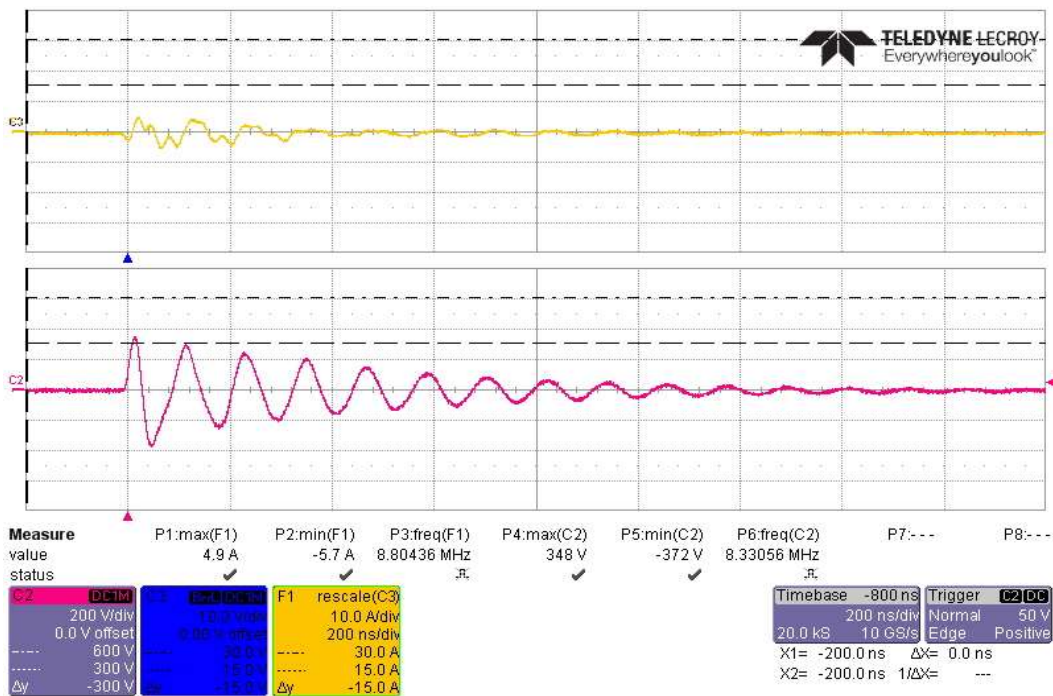

Actual Test CS117 Waveform #3 at 10MHz, Subsequent Transient +300V, on Battery High Side

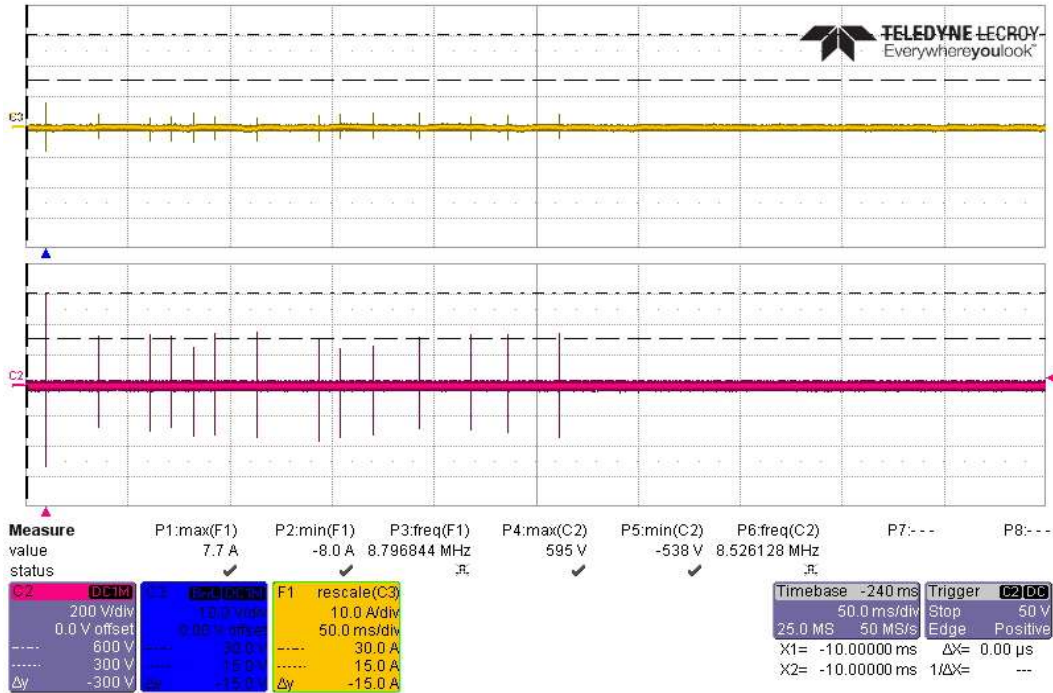

Actual Test CS117 Waveform #3 at 10MHz, 14 Transients +600/+300V, on Battery High Side

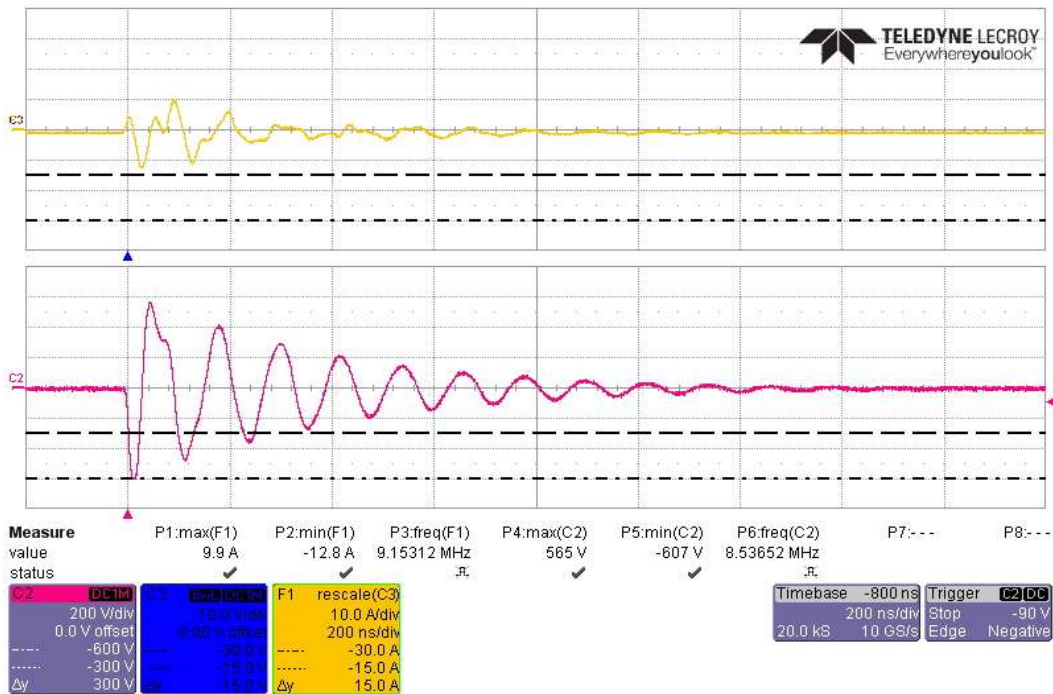

Actual Test CS117 Waveform #3 at 10MHz, First Transient -600V, on Battery High Side

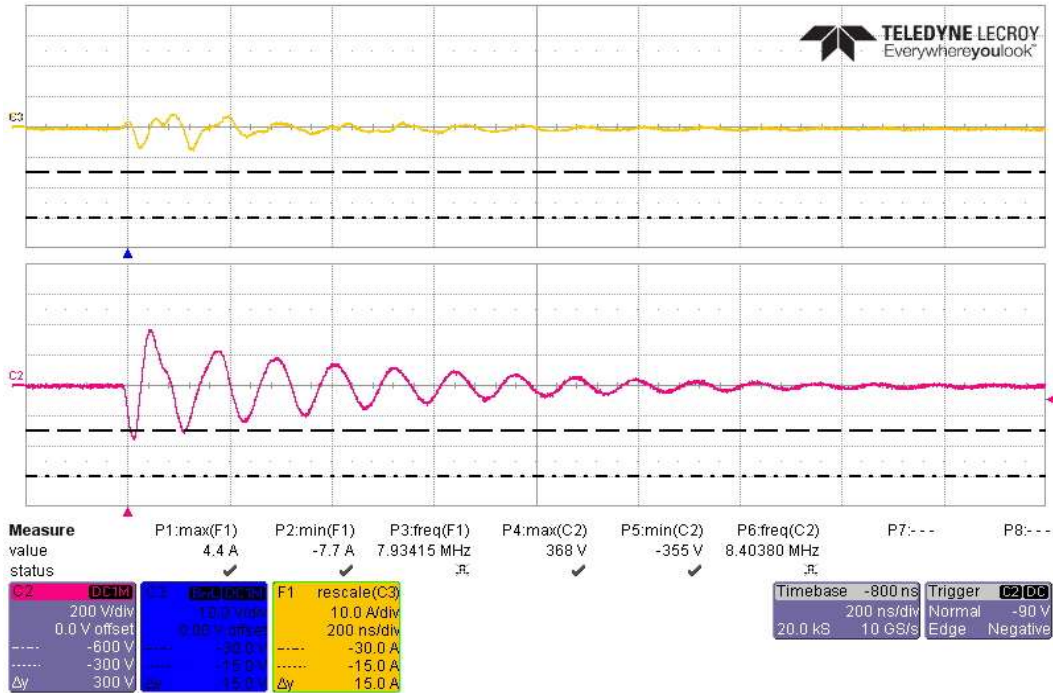

Actual Test CS117 Waveform #3 at 10MHz, Subsequent Transient -300V, on Battery High Side

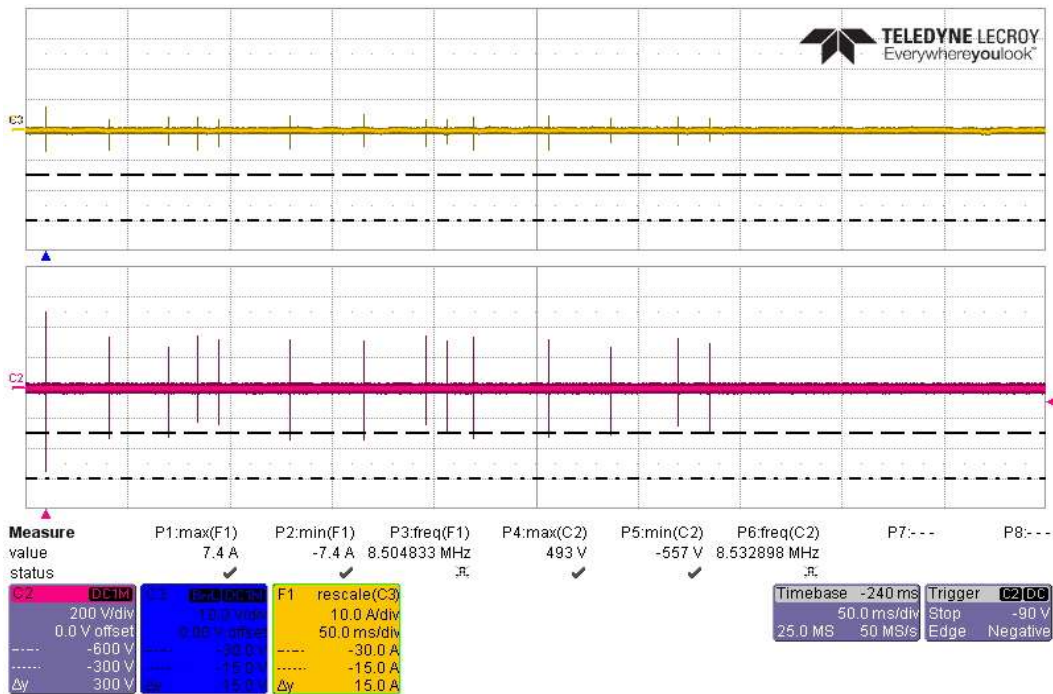

Actual Test CS117 Waveform #3 at 10MHz, 14 Transients -600/-300V, on Battery High Side

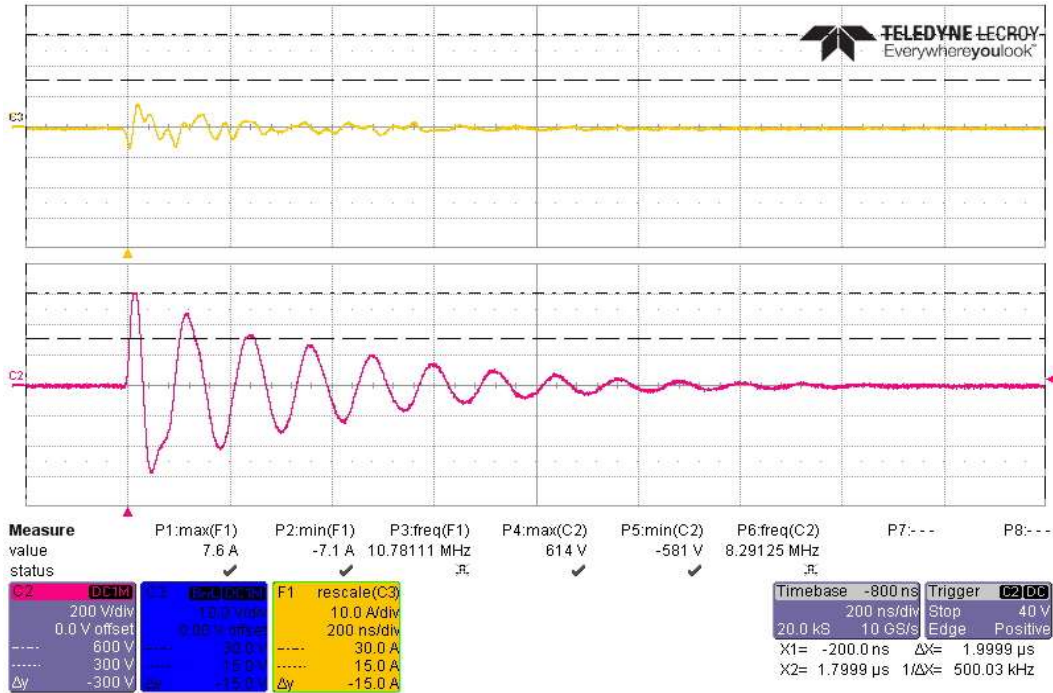

Actual Test CS117 Waveform #3 at 10MHz, First Transient +600V, on Battery Return Side

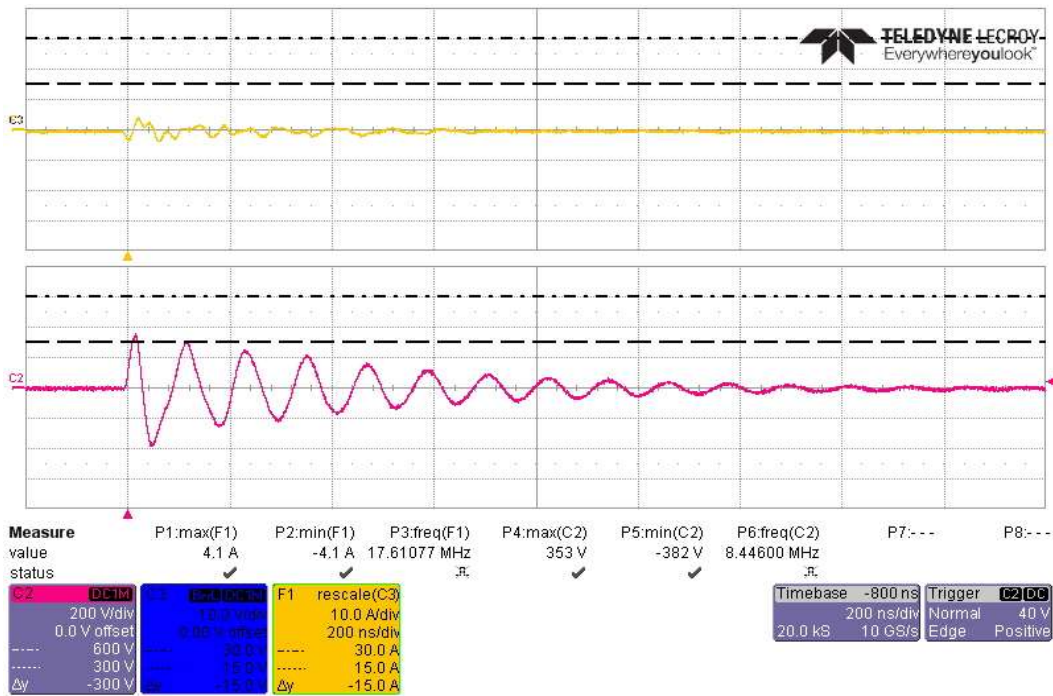

Actual Test CS117 Waveform #3 at 10MHz, Subsequent Transient +300V, on Battery Return Side

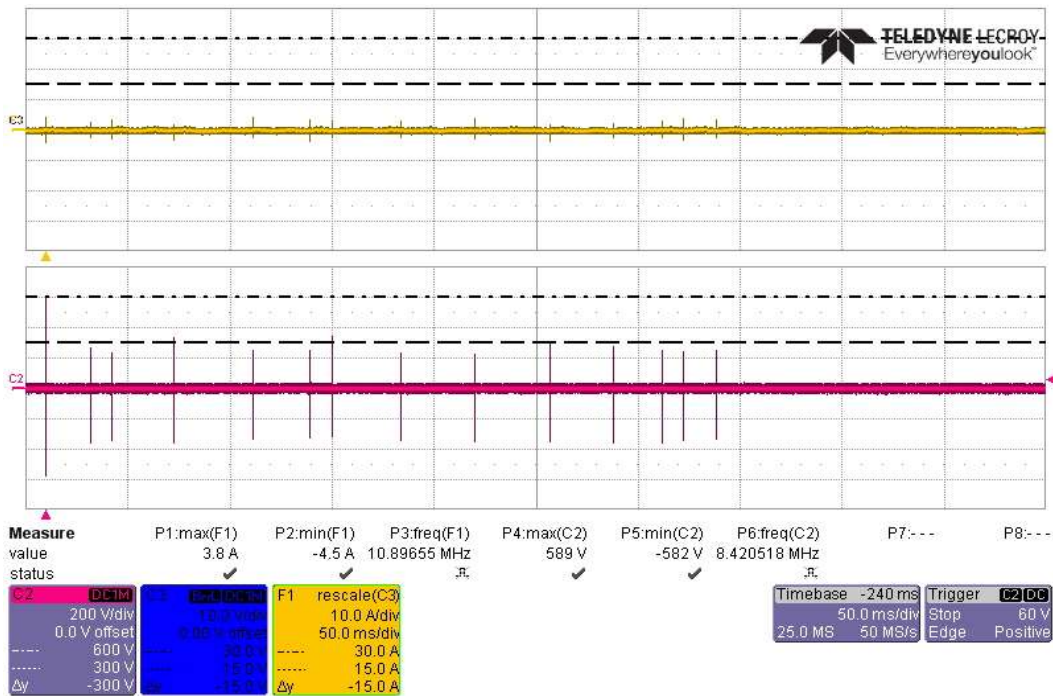

Actual Test CS117 Waveform #3 at 10MHz, 14 Transients +600/+300V, on Battery Return Side

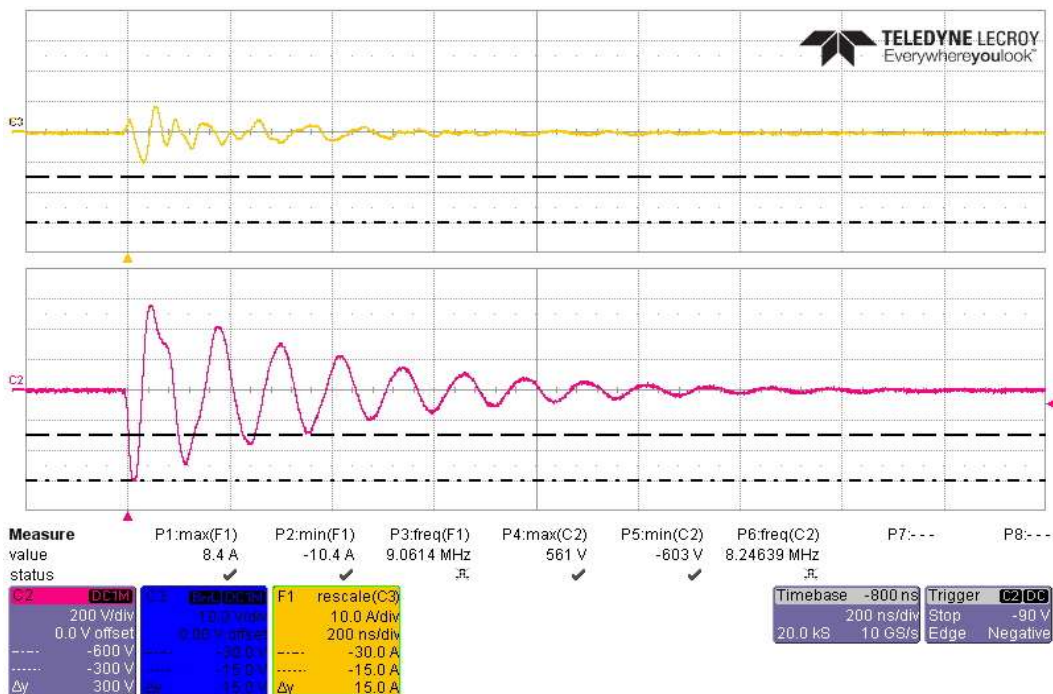

Actual Test CS117 Waveform #3 at 10MHz, First Transient -600V, on Battery Return Side

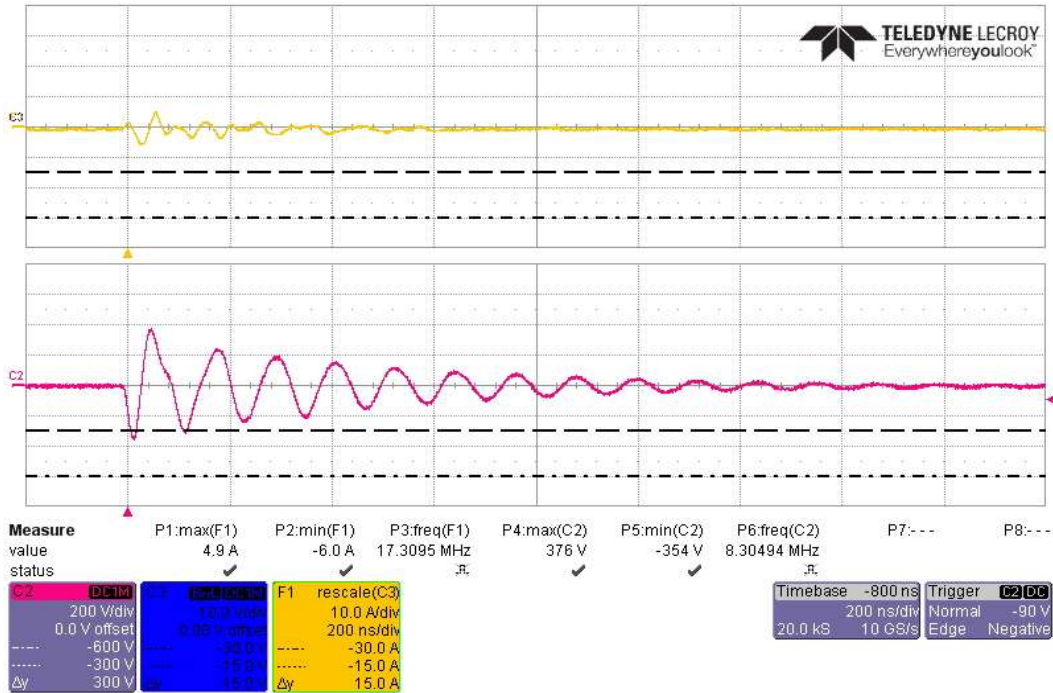

Actual Test CS117 Waveform #3 at 10MHz, Subsequent Transient -300V, on Battery Return Side

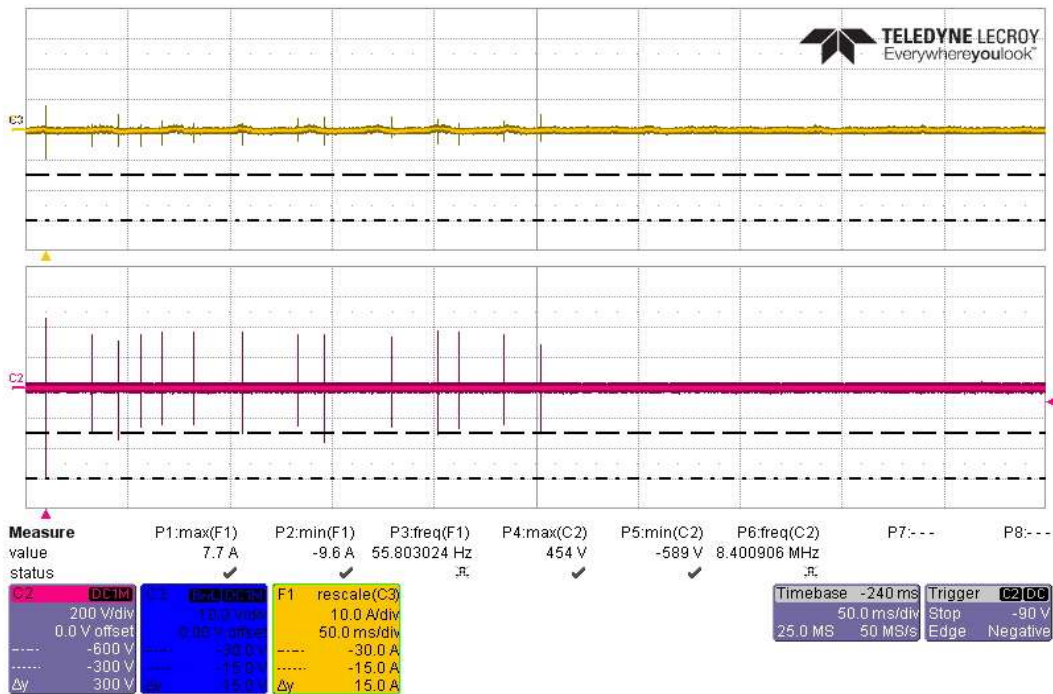

Actual Test CS117 Waveform #3 at 10MHz, 14 Transients -600/-300V, on Battery Return Side

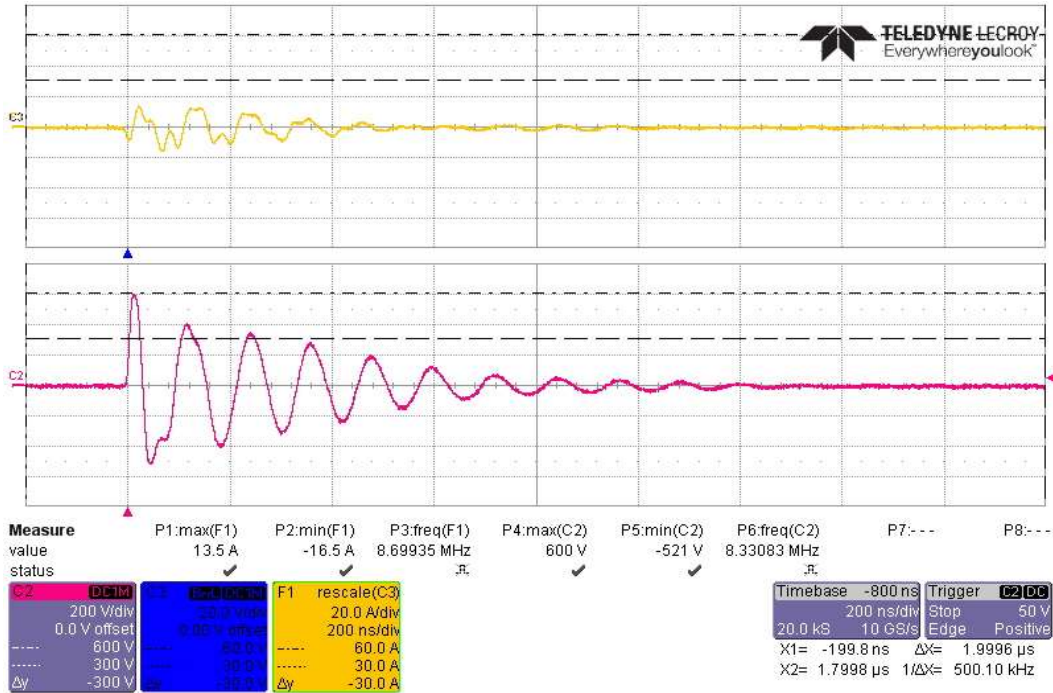

Actual Test CS117 Waveform #3 at 10MHz, First Transient +600V, on Battery Bundle

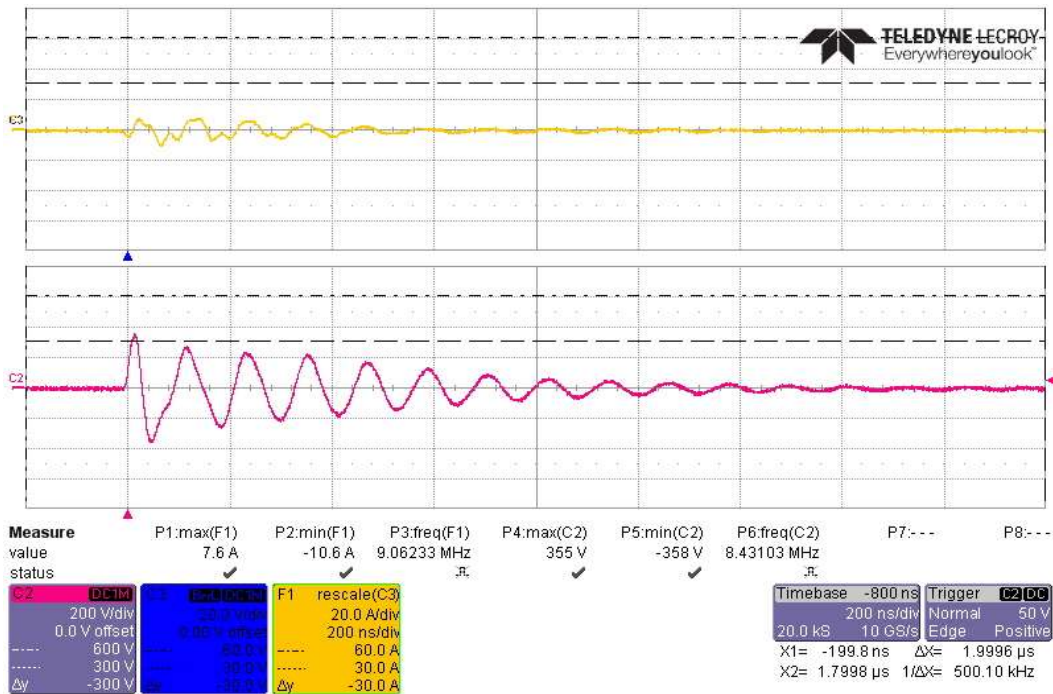

Actual Test CS117 Waveform #3 at 10MHz, Subsequent Transient +300V, on Battery Bundle

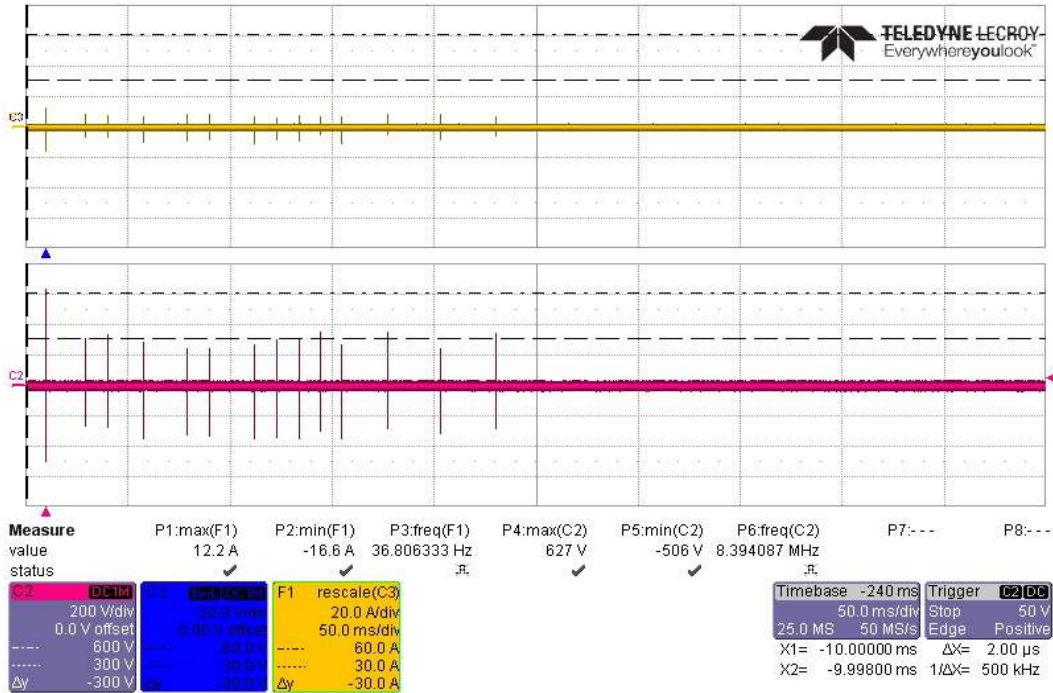

Actual Test CS117 Waveform #3 at 10MHz, 14 Transients +600/+300V, on Battery Bundle

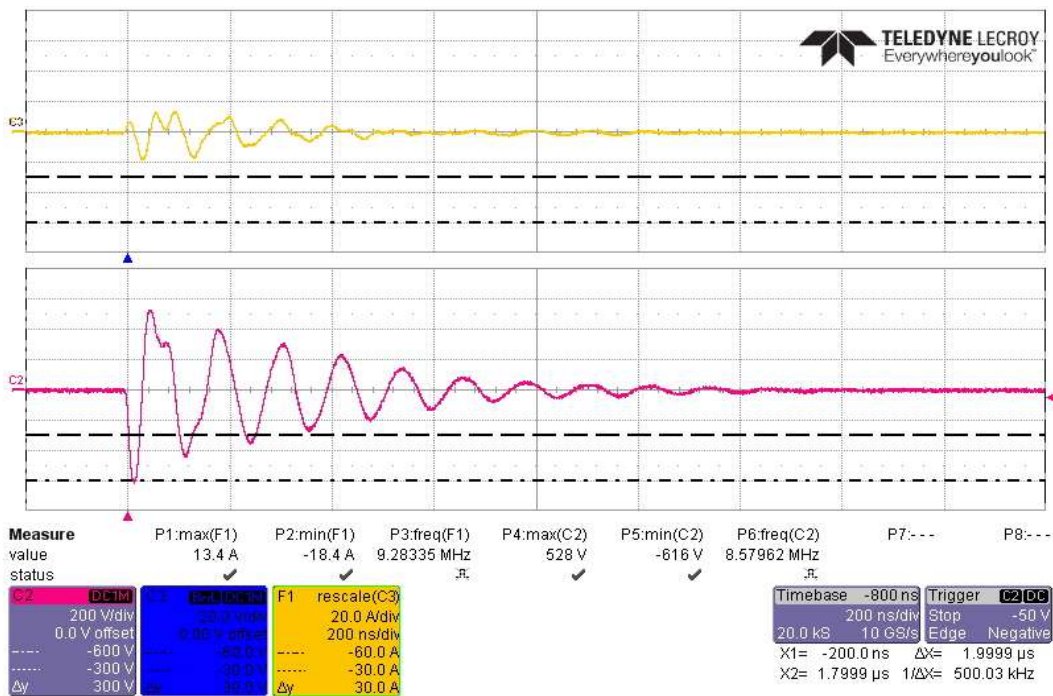

Actual Test CS117 Waveform #3 at 10MHz, First Transient -600V, on Battery Bundle

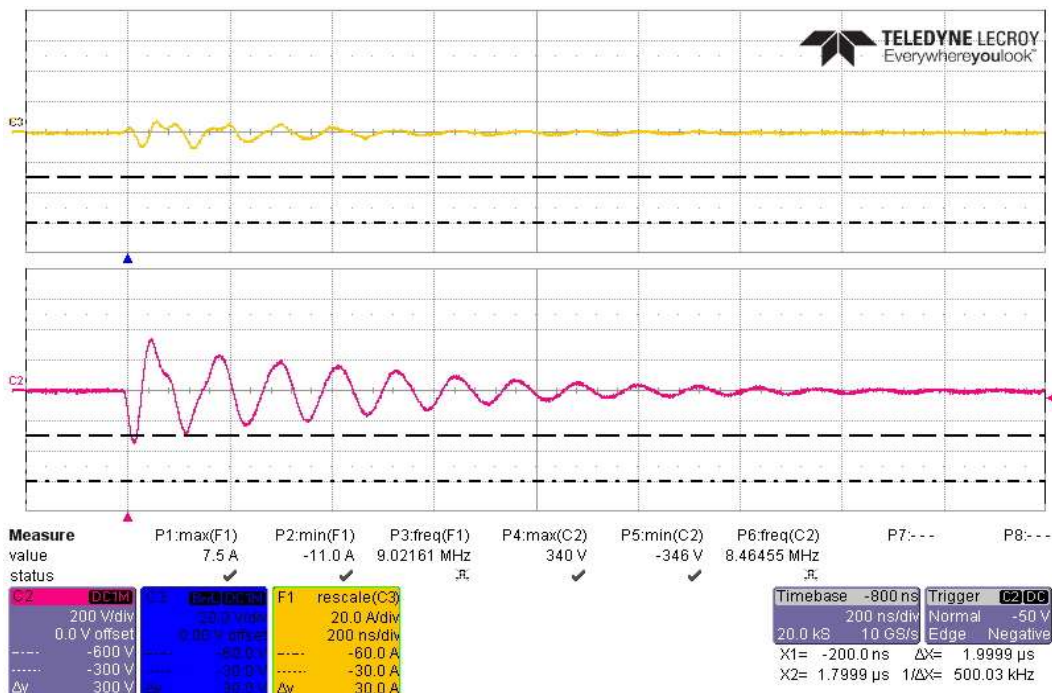

Actual Test CS117 Waveform #3 at 10MHz, Subsequent Transient -300V, on Battery Bundle

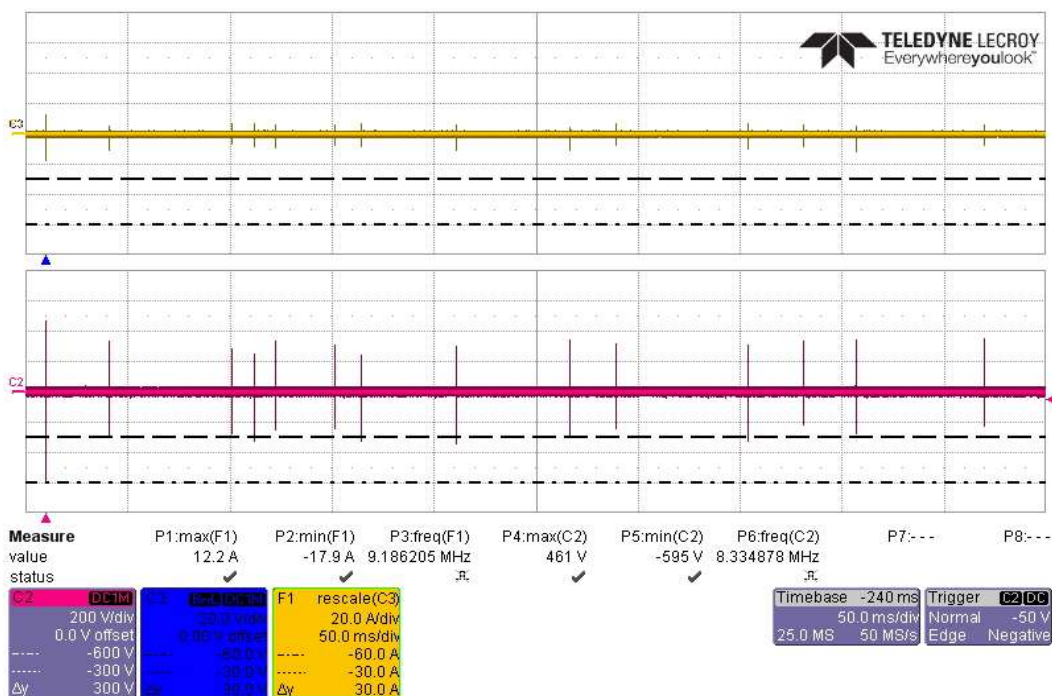

Actual Test CS117 Waveform #3 at 10MHz, 14 Transients -600/-300V, on Battery Bundle

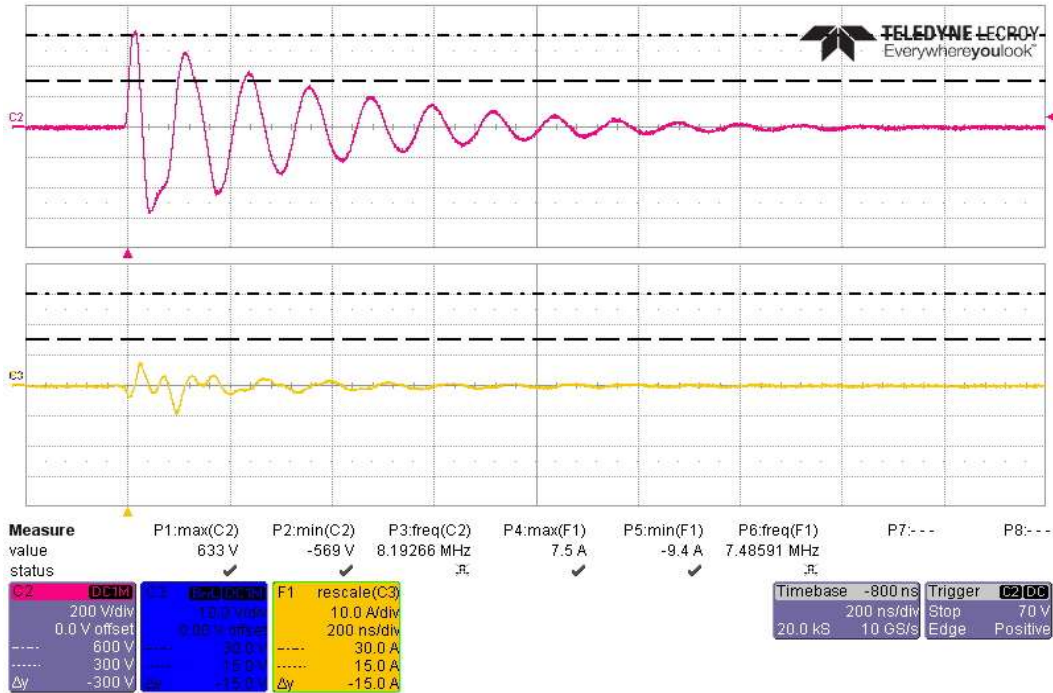

Actual Test CS117 Waveform #3 at 10MHz, First Transient +600V, on PV High Side

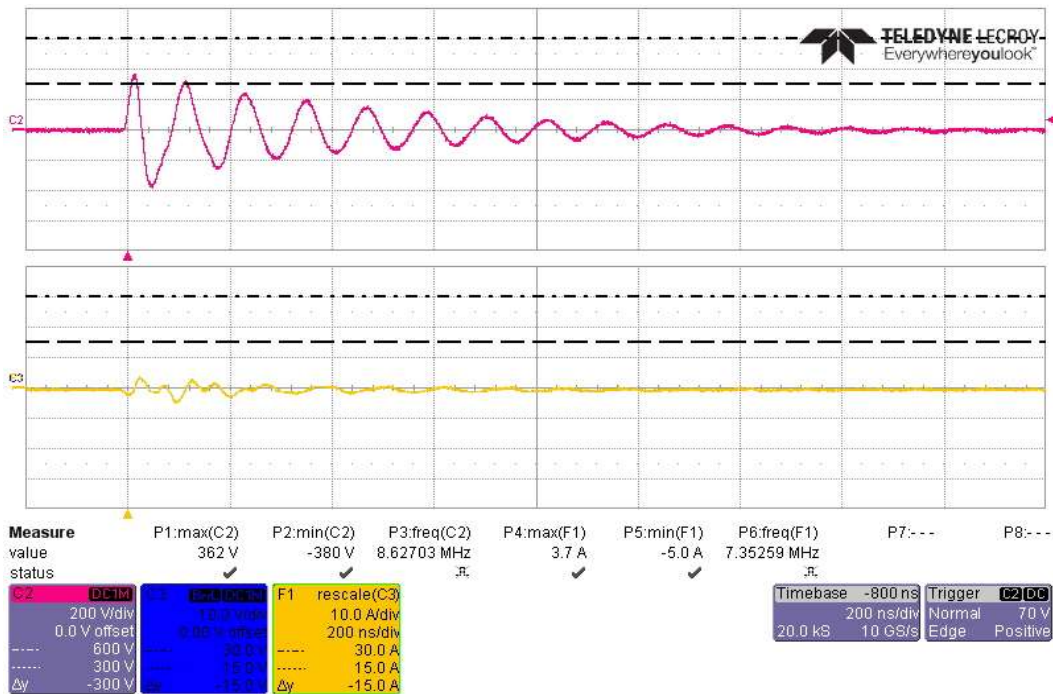

Actual Test CS117 Waveform #3 at 10MHz, Subsequent Transient +300V, on PV High Side

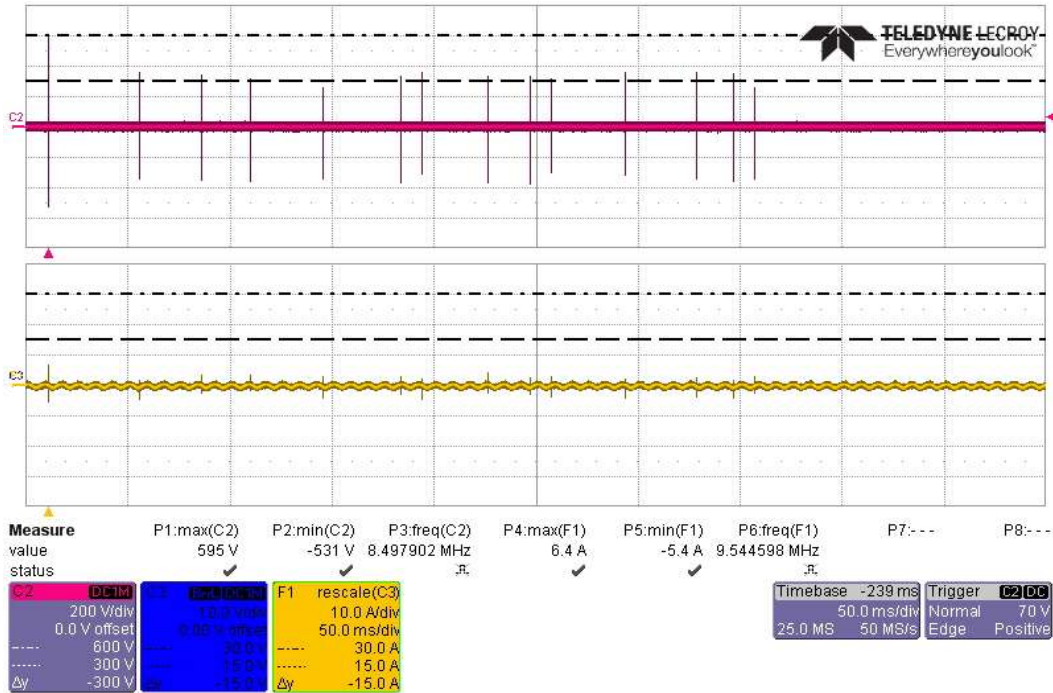

Actual Test CS117 Waveform #3 at 10MHz, 14 Transients +600/+300V, on PV High Side

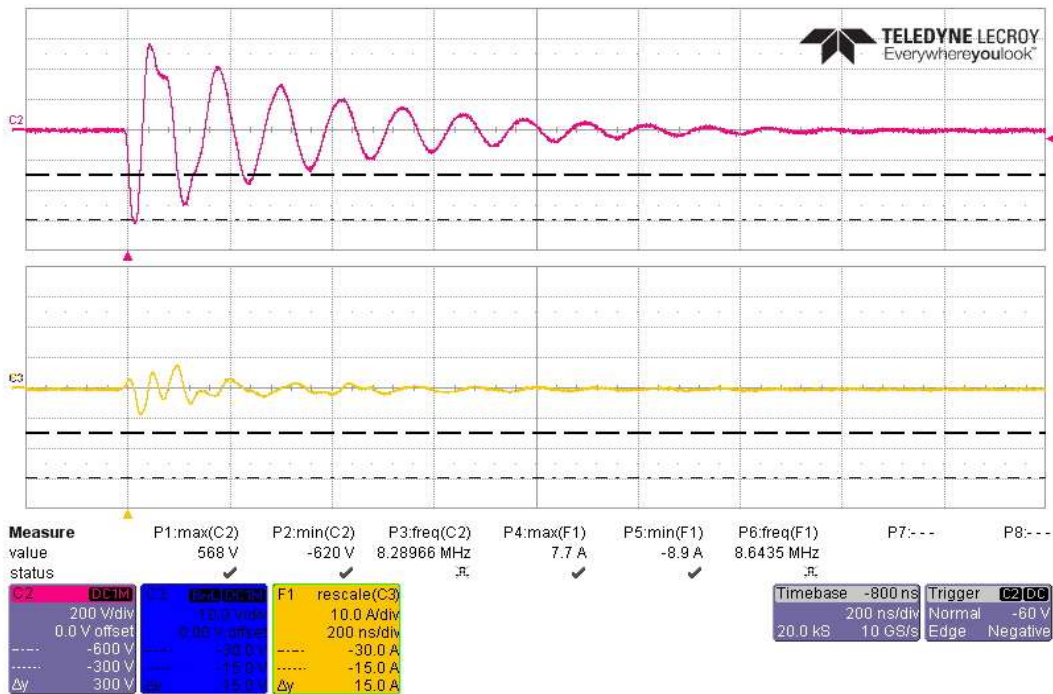

Actual Test CS117 Waveform #3 at 10MHz, First Transient -600V, on PV High Side

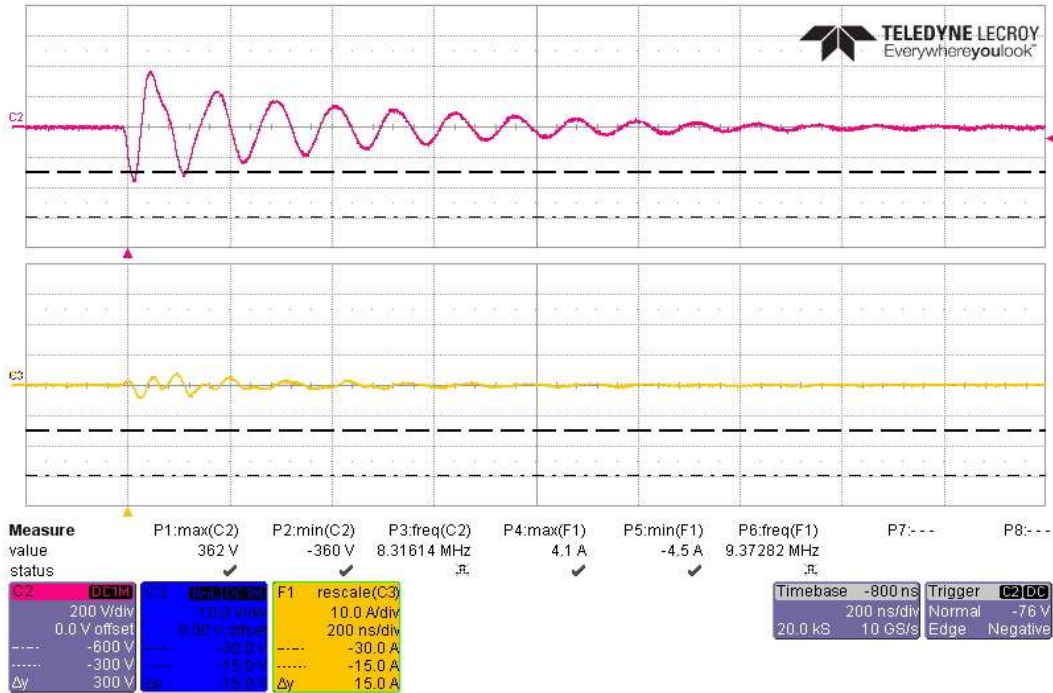

Actual Test CS117 Waveform #3 at 10MHz, Subsequent Transient -300V, on PV High Side

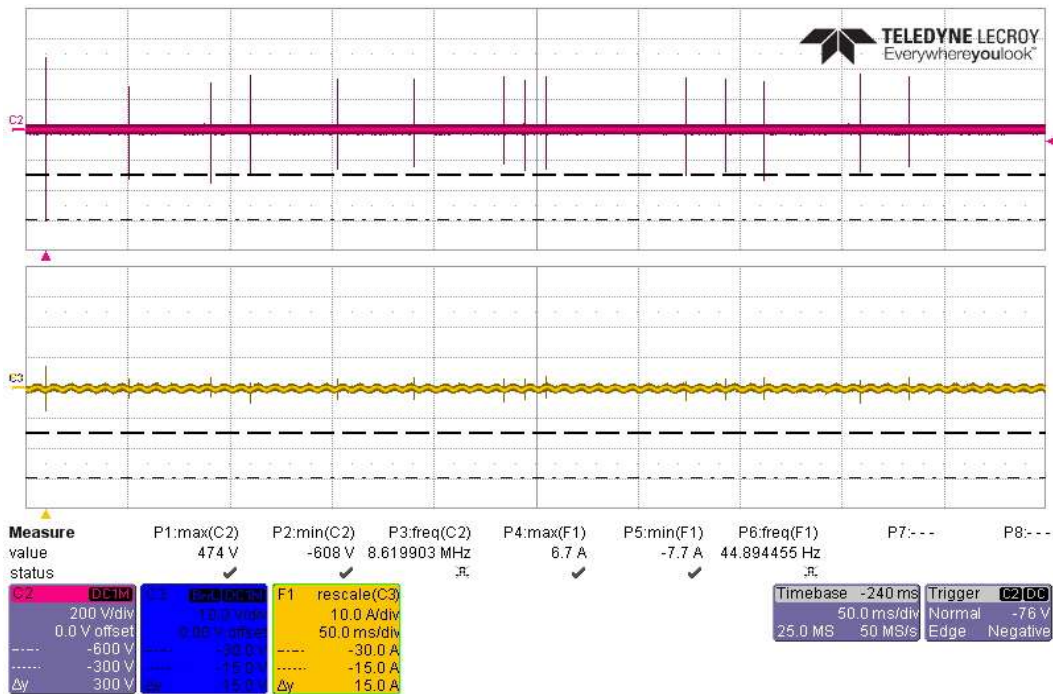

Actual Test CS117 Waveform #3 at 10MHz, 14 Transients -600/-300V, on PV High Side

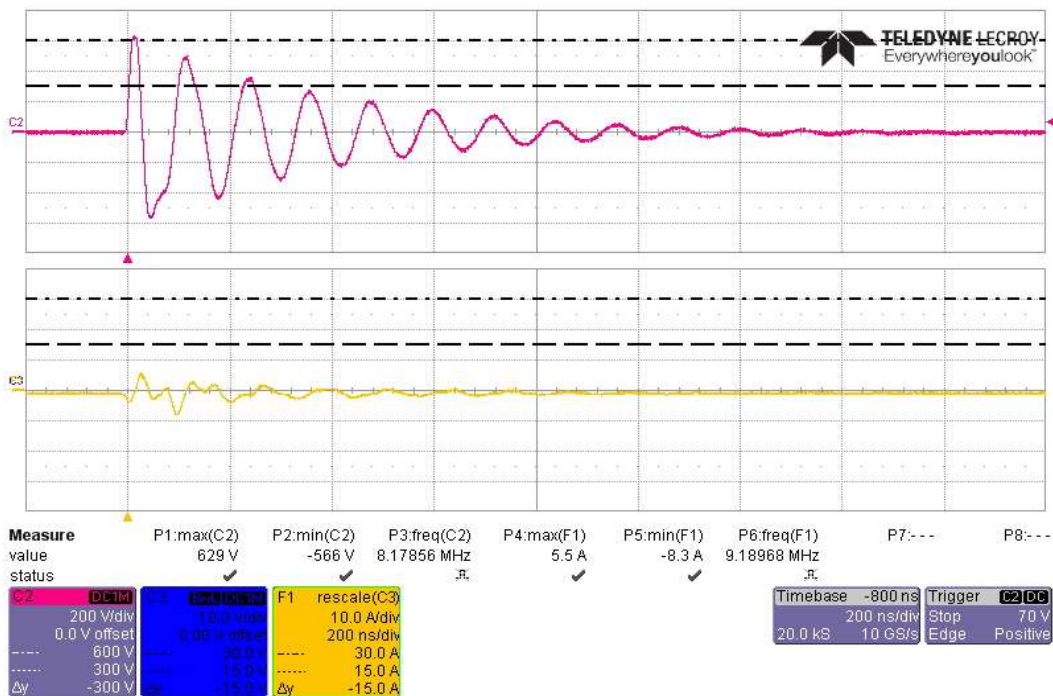

Actual Test CS117 Waveform #3 at 10MHz, First Transient +600V, on PV Return Side

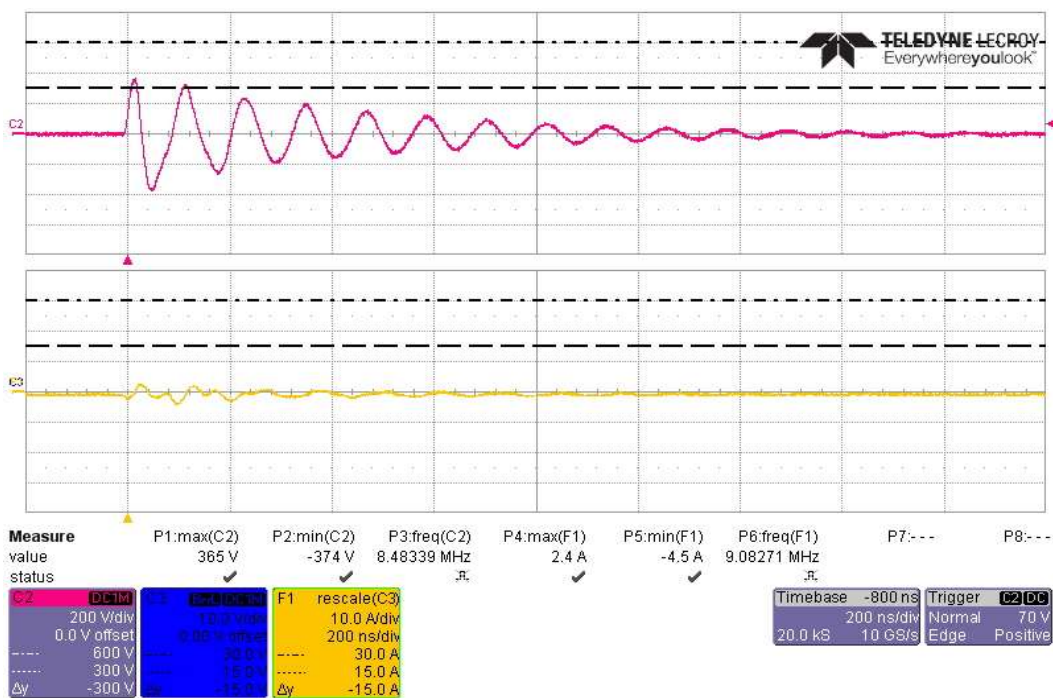

Actual Test CS117 Waveform #3 at 10MHz, Subsequent Transient +300V, on PV Return Side

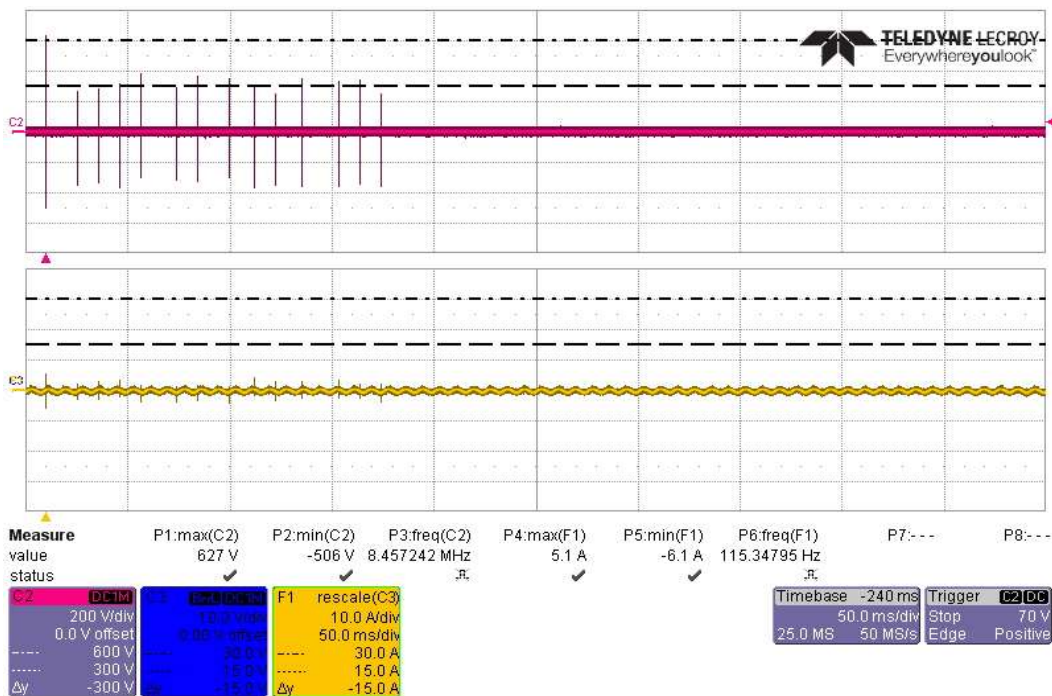

Actual Test CS117 Waveform #3 at 10MHz, 14 Transients +600/+300V, on PV Return Side

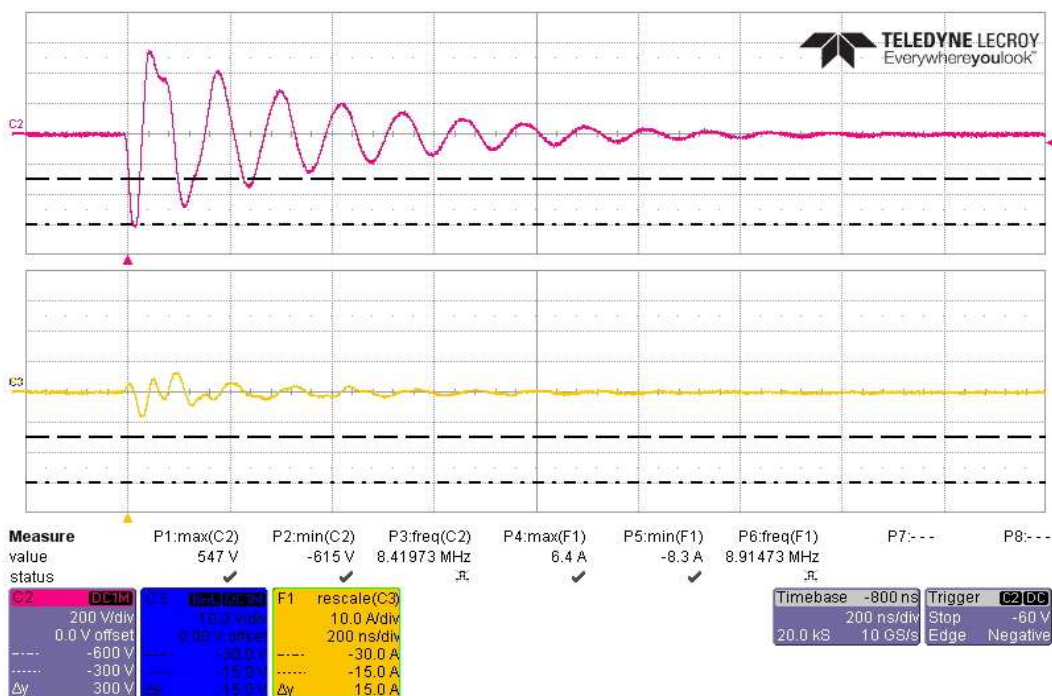

Actual Test CS117 Waveform #3 at 10MHz, First Transient -600V, on PV Return Side

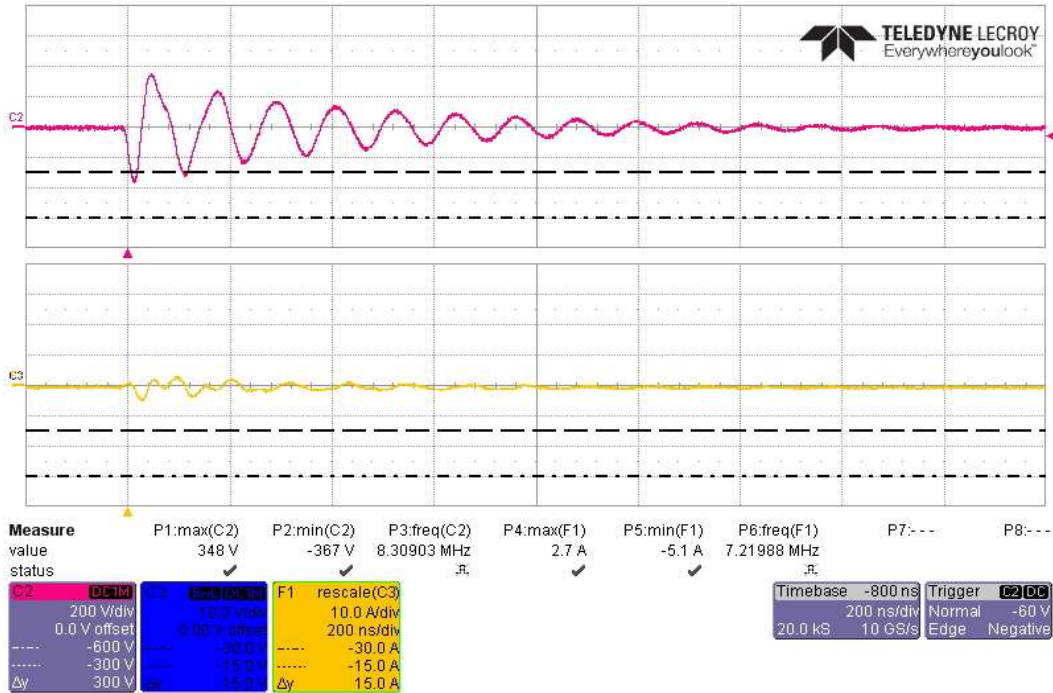

Actual Test CS117 Waveform #3 at 10MHz, Subsequent Transient -300V, on PV Return Side

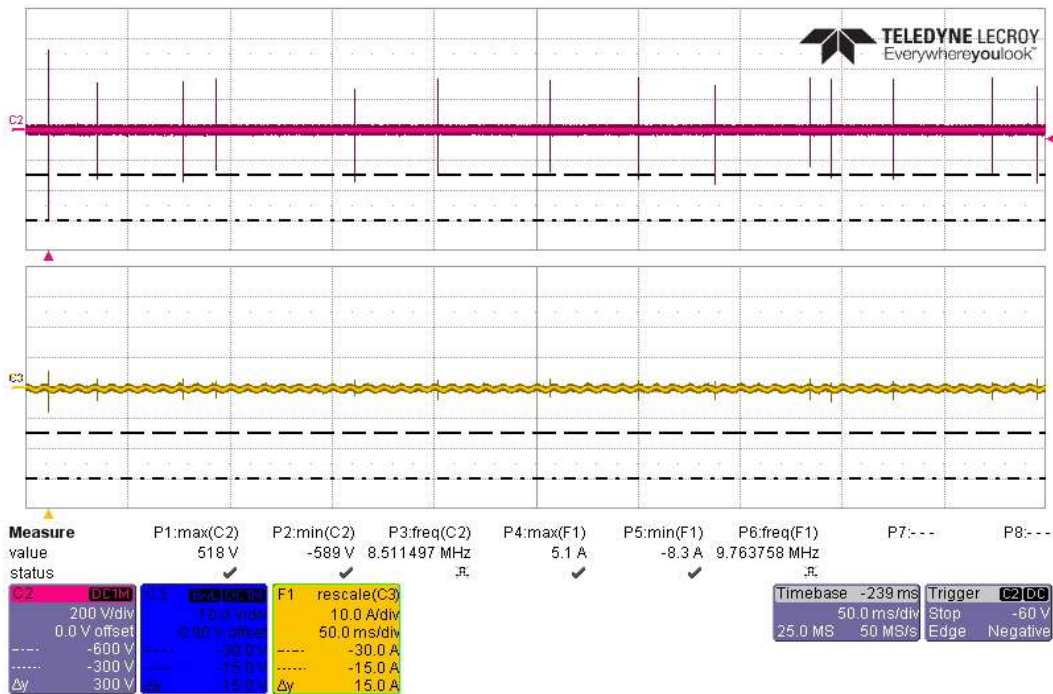

Actual Test CS117 Waveform #3 at 10MHz, 14 Transients -600/-300V, on PV Return Side

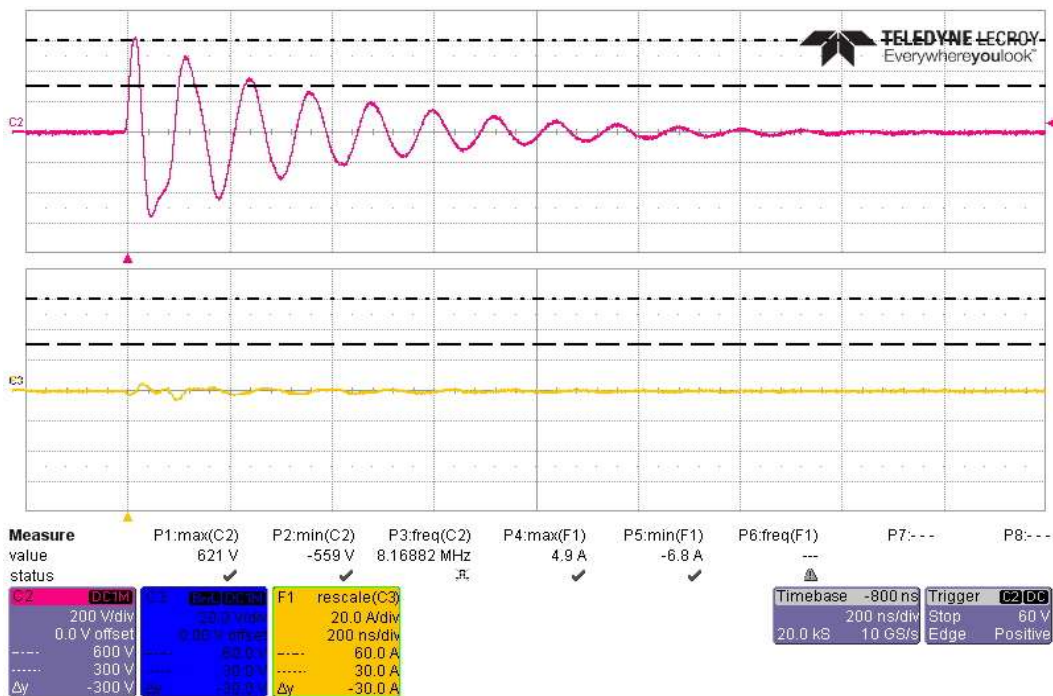

Actual Test CS117 Waveform #3 at 10MHz, First Transient +600V, on PV Bundle

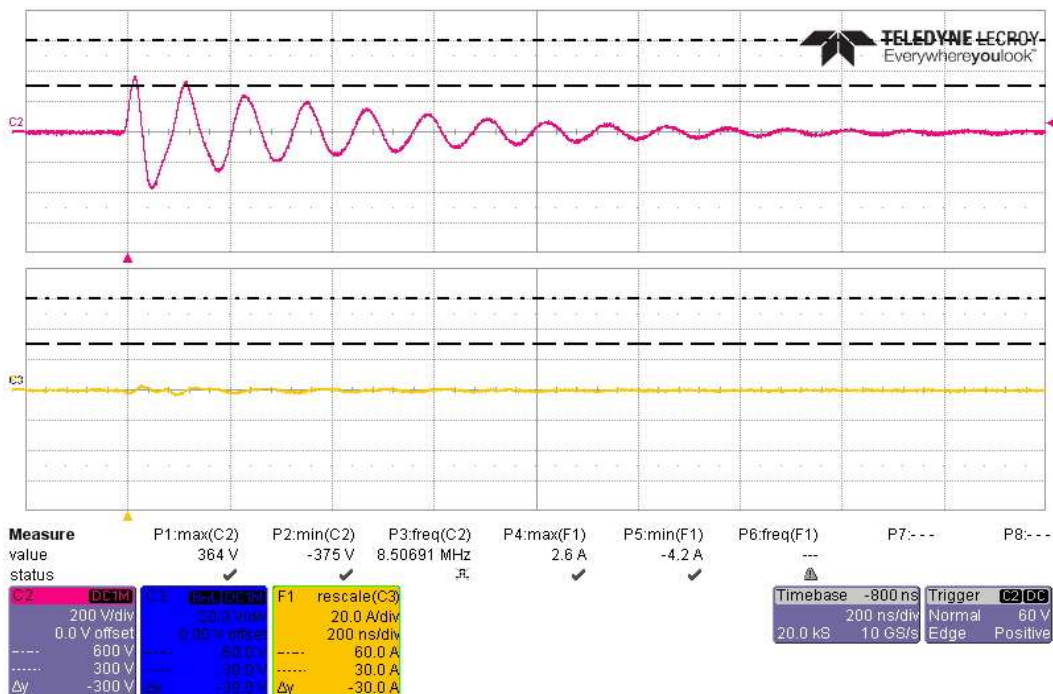

Actual Test CS117 Waveform #3 at 10MHz, Subsequent Transient +300V, on PV Bundle

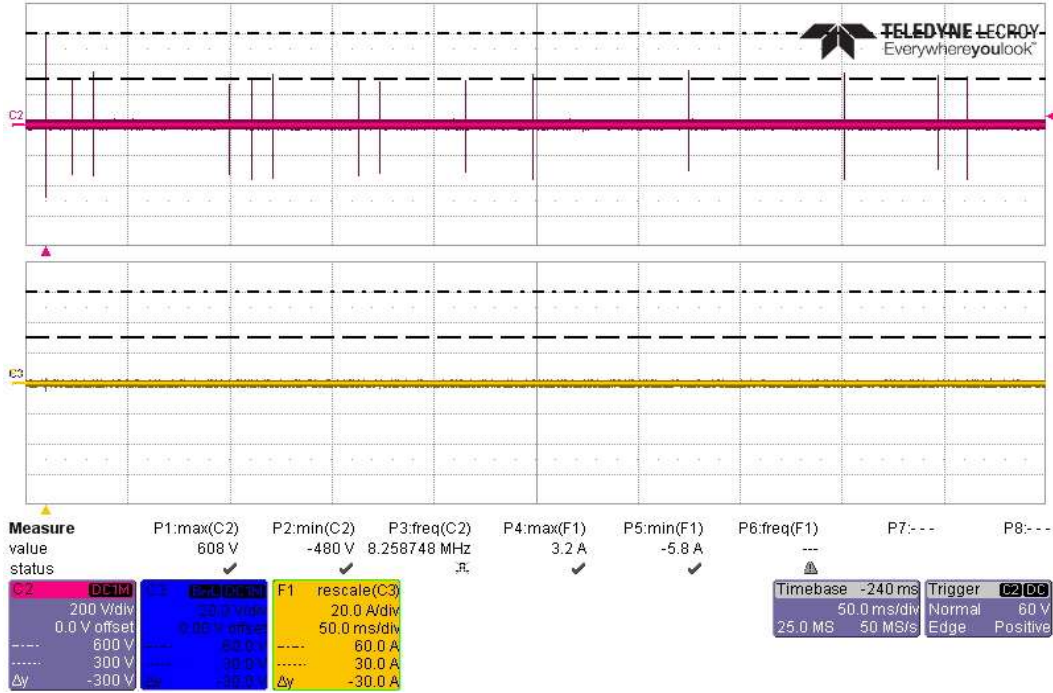

Actual Test CS117 Waveform #3 at 10MHz, 14 Transients +600/+300V, on PV Bundle

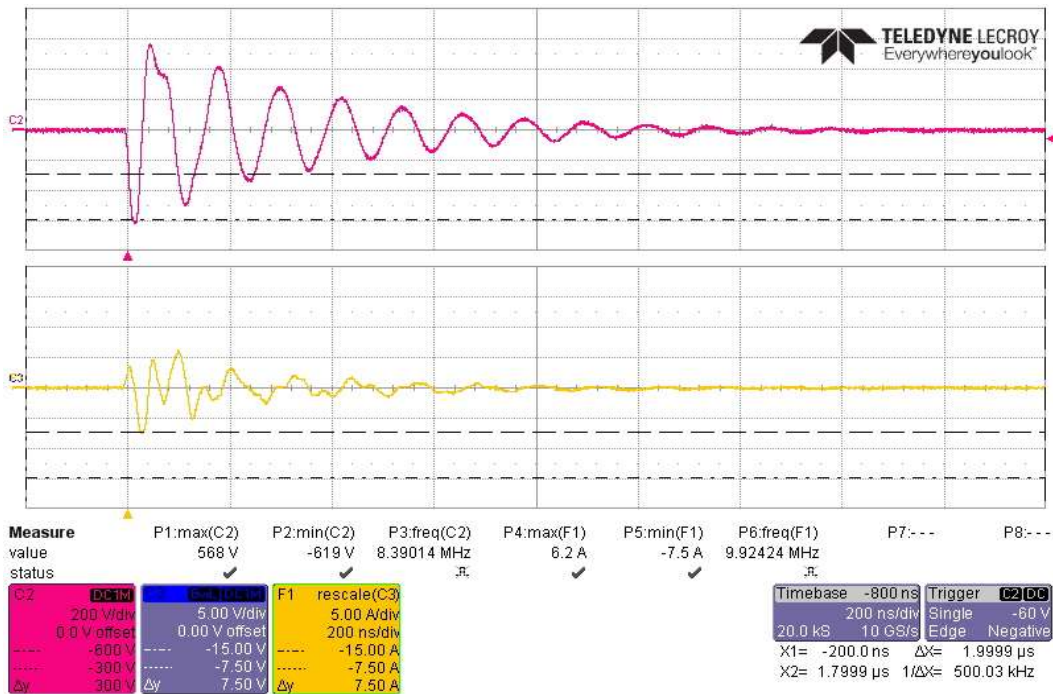

Actual Test CS117 Waveform #3 at 10MHz, First Transient -600V, on PV Bundle

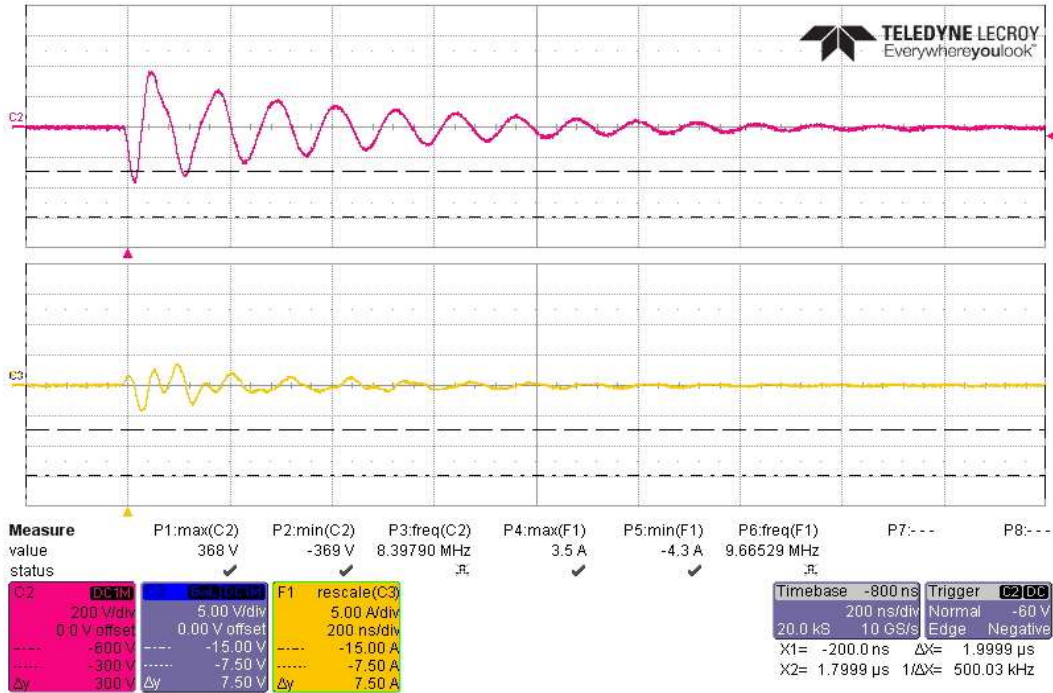

Actual Test CS117 Waveform #3 at 10MHz, Subsequent Transient -300V, on PV Bundle

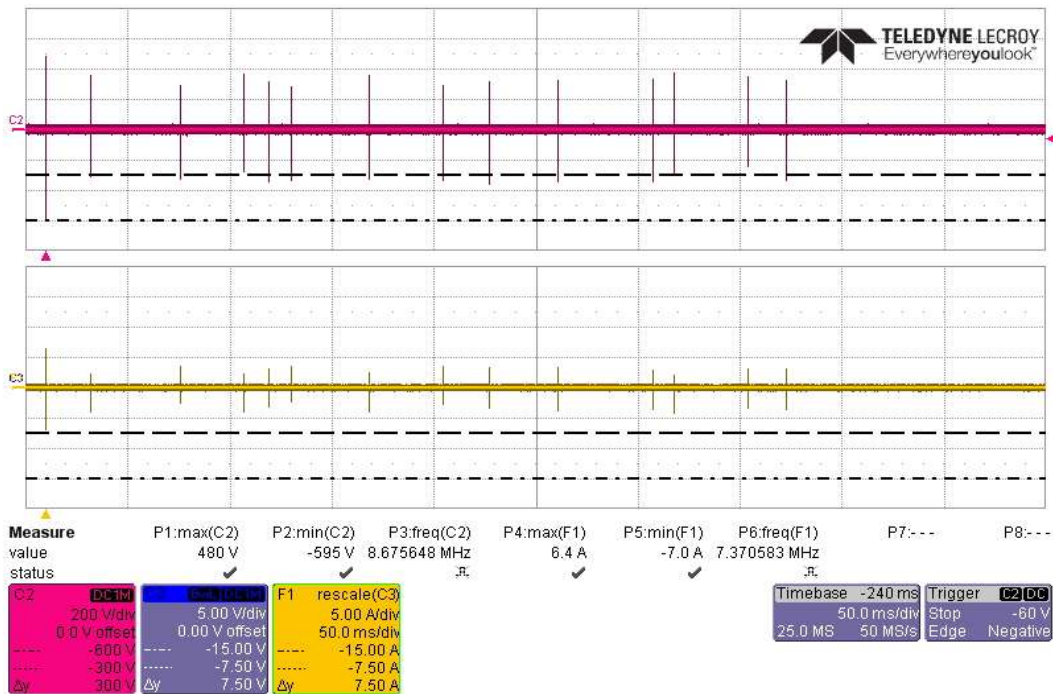

Actual Test CS117 Waveform #3 at 10MHz, 14 Transients -600/-300V, on PV Bundle

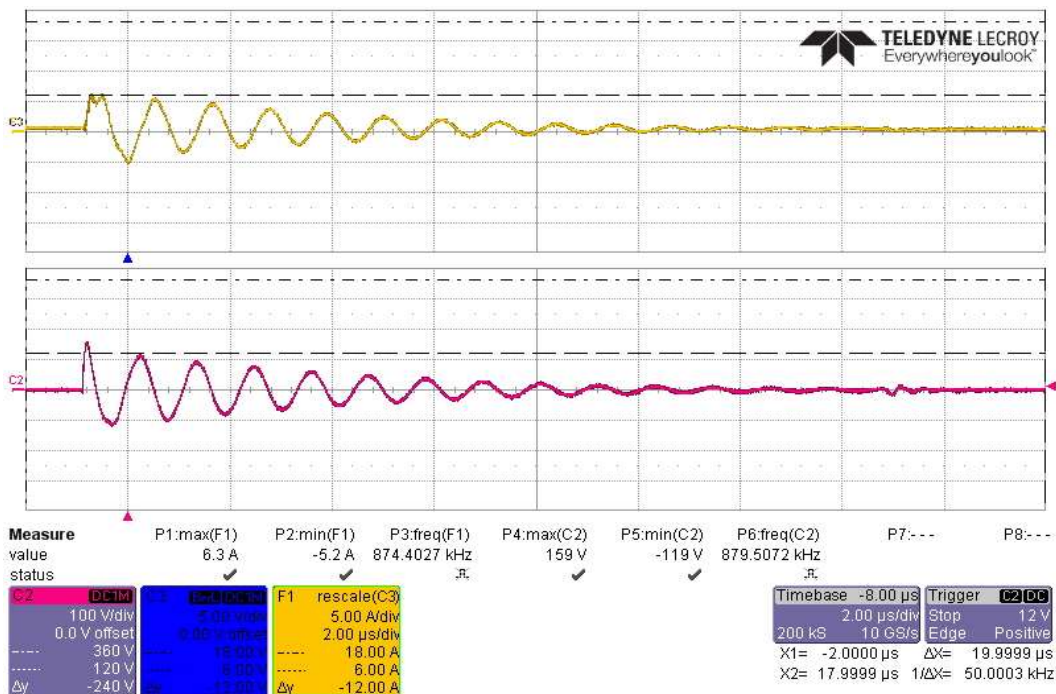
CS117 Actual Test Multiple Burst Waveform #3 at 1MHz with 360V/6A

Actual Test CS117 Waveform #3 at 1MHz, First Transient +360V/6A, on Power Line 1

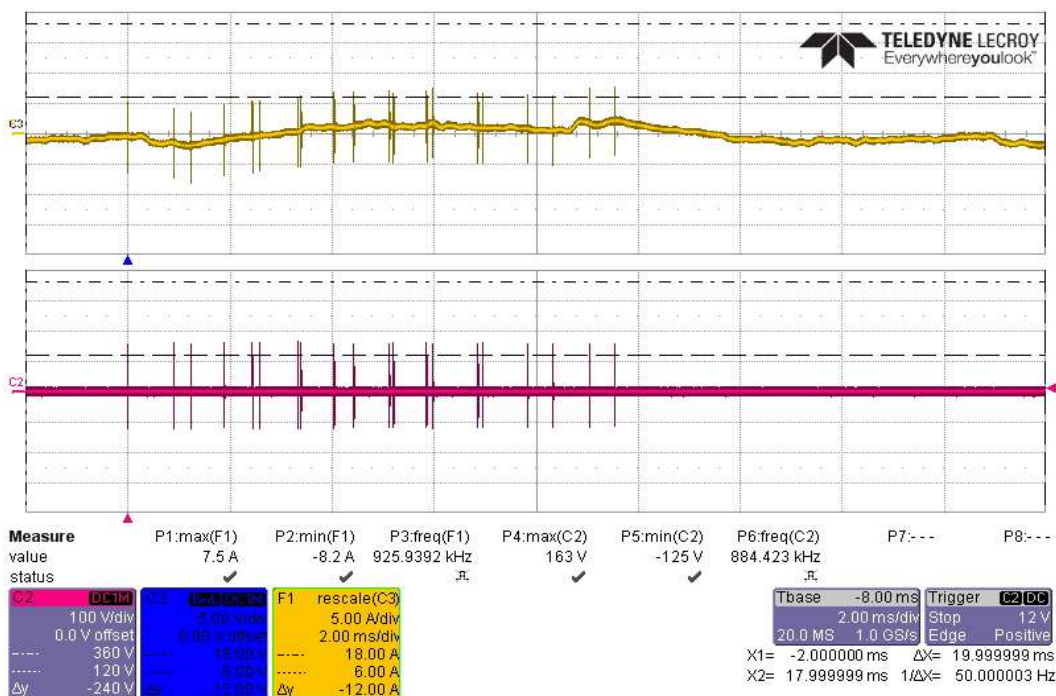

Actual Test CS117 Waveform #3 at 1MHz, 20 Transients +360V/6A, on Power Line 1

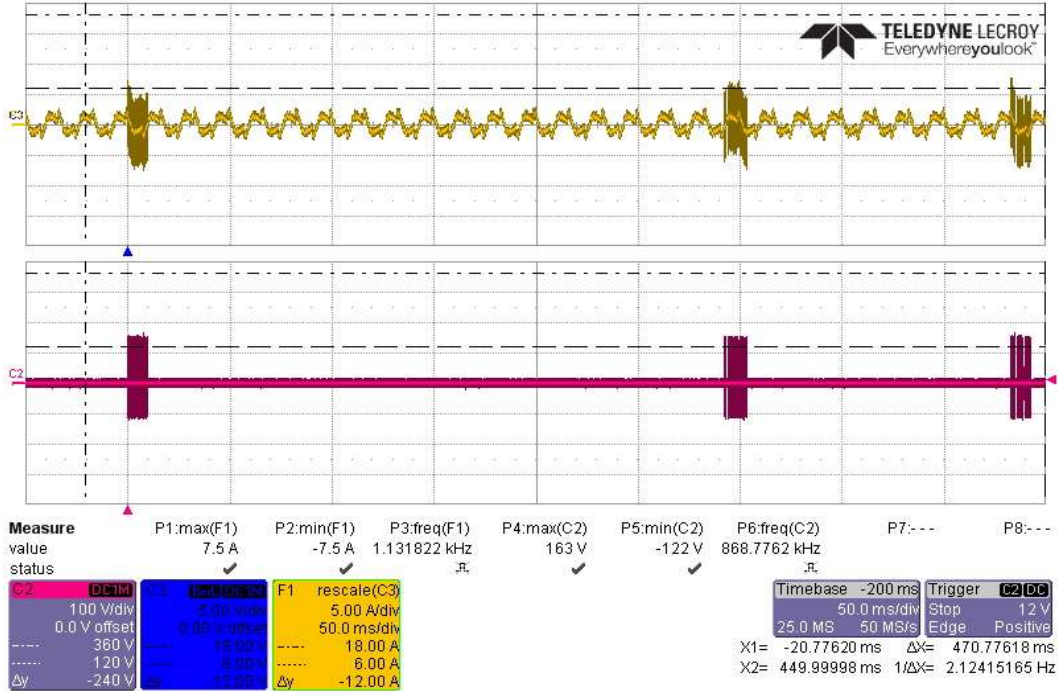

Actual Test CS117 Waveform #3 at 1MHz, 3 Bursts +360V/6A, on Power Line 1

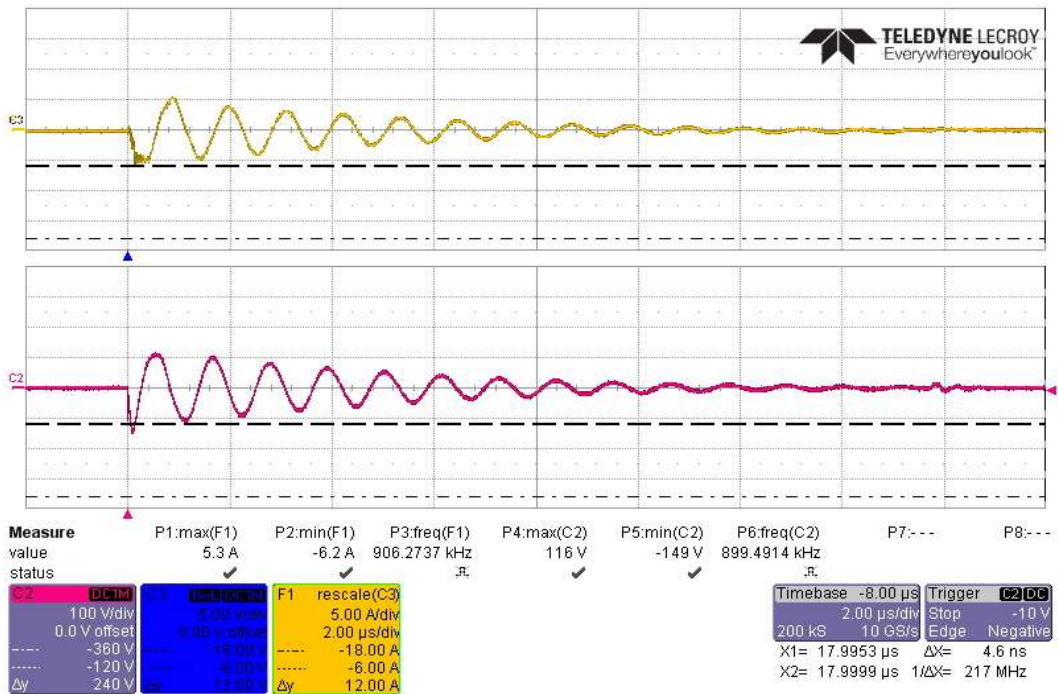

Actual Test CS117 Waveform #3 at 1MHz, First Transient -360V/6A, on Power Line 1

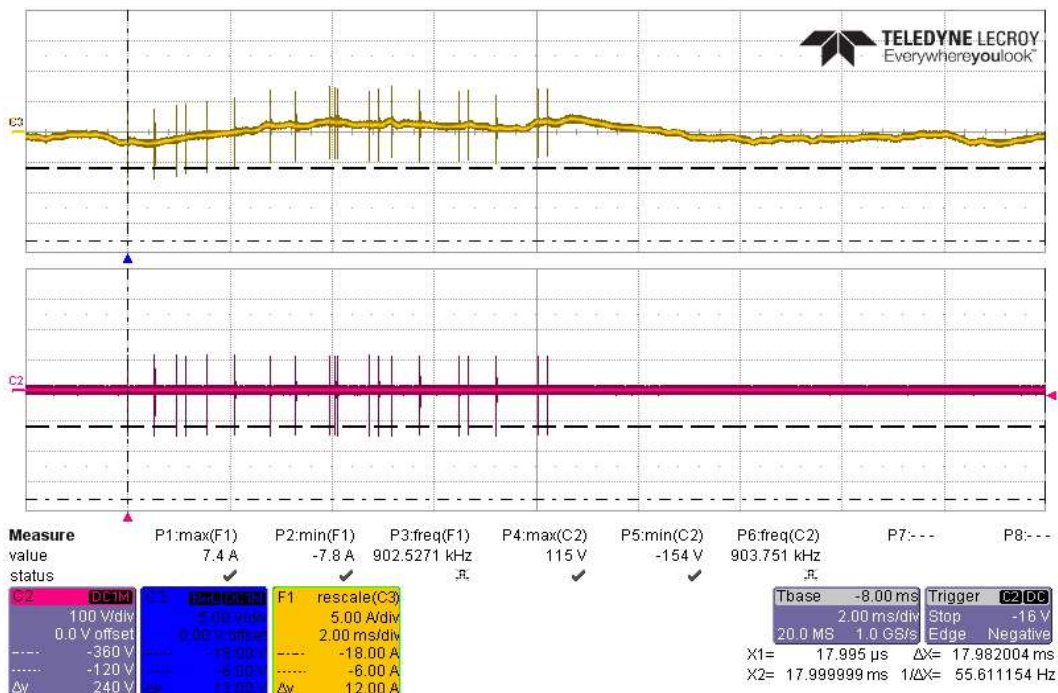

Actual Test CS117 Waveform #3 at 1MHz, 20 Transients -360V/6A, on Power Line 1

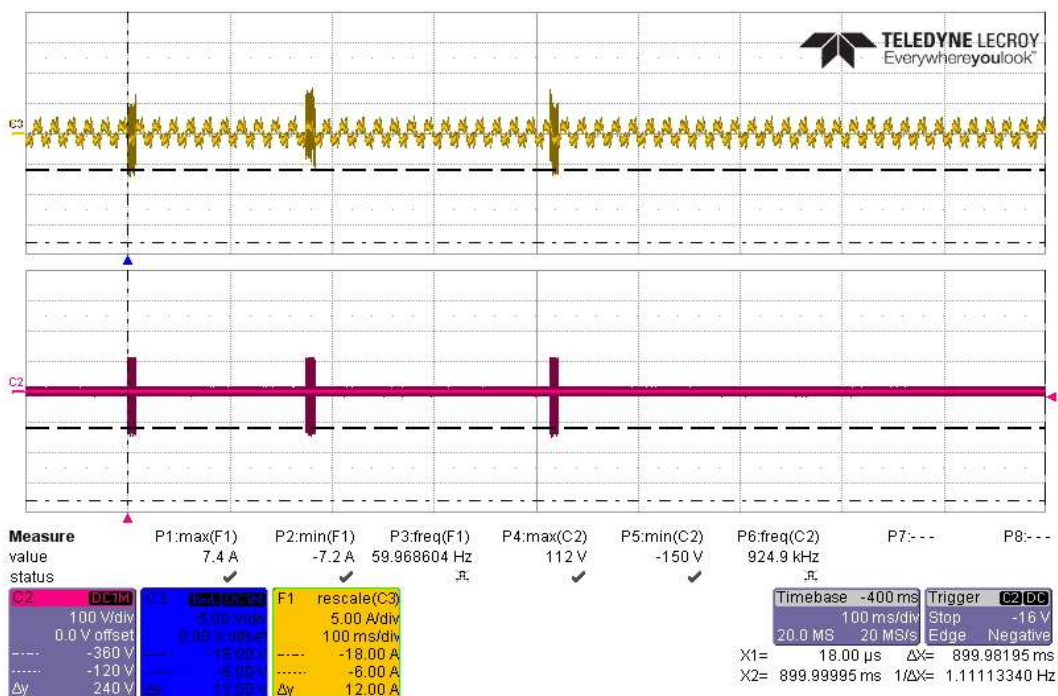

Actual Test CS117 Waveform #3 at 1MHz, 3 Bursts -360V/6A, on Power Line 1

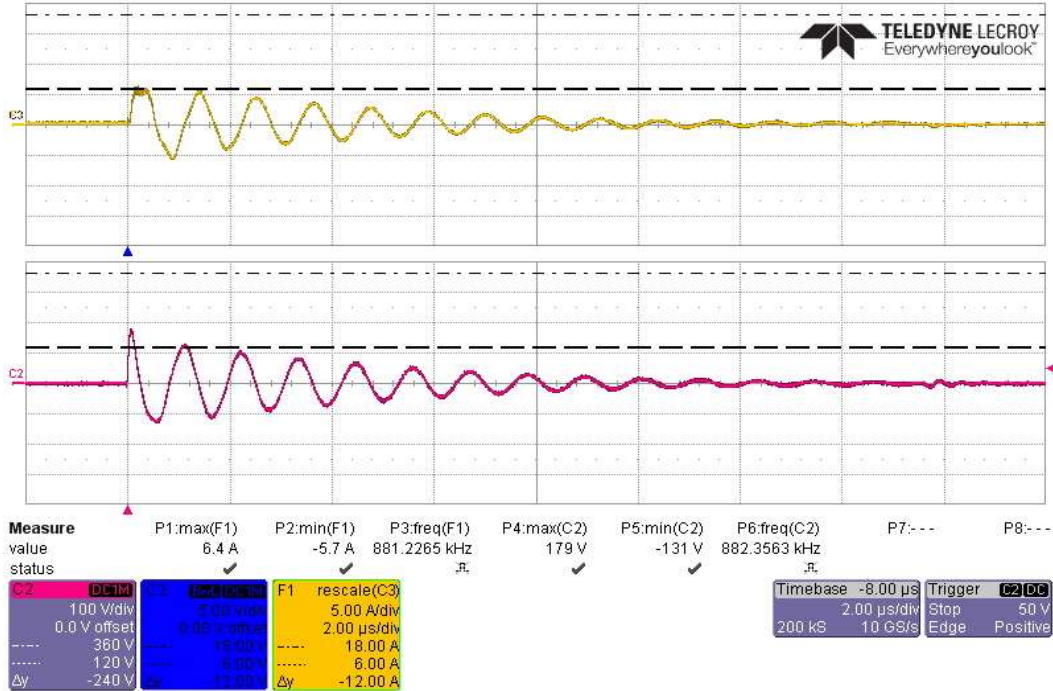

Actual Test CS117 Waveform #3 at 1MHz, First Transient +360V/6A, on Power Line 2

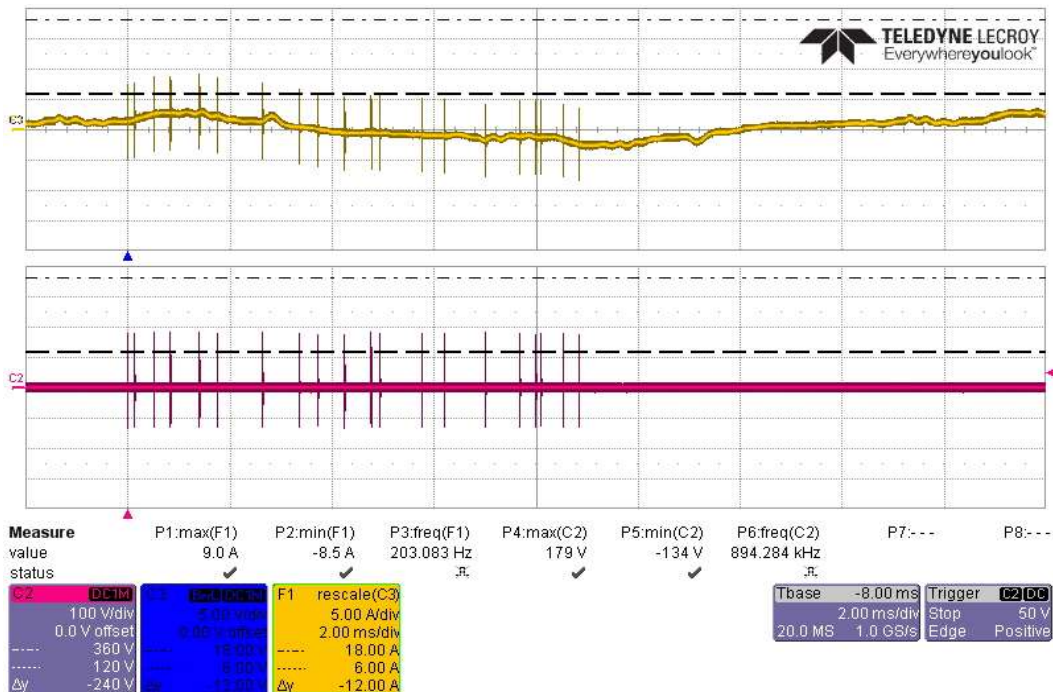

Actual Test CS117 Waveform #3 at 1MHz, 20 Transients +360V/6A, on Power Line 2

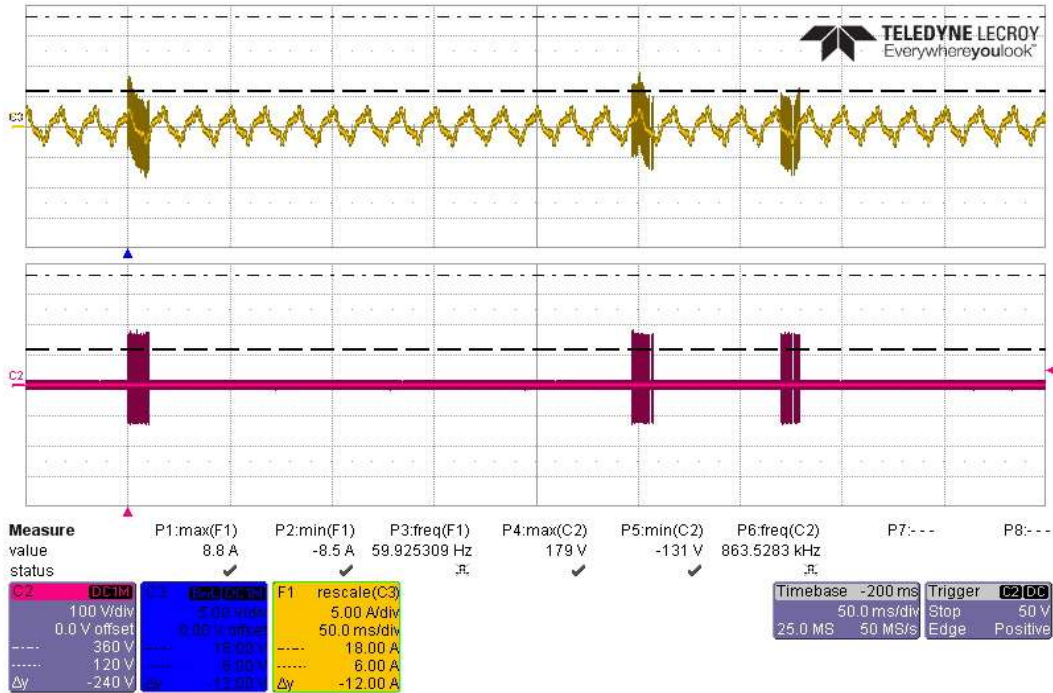

Actual Test CS117 Waveform #3 at 1MHz, 3 Bursts +360V/6A, on Power Line 2

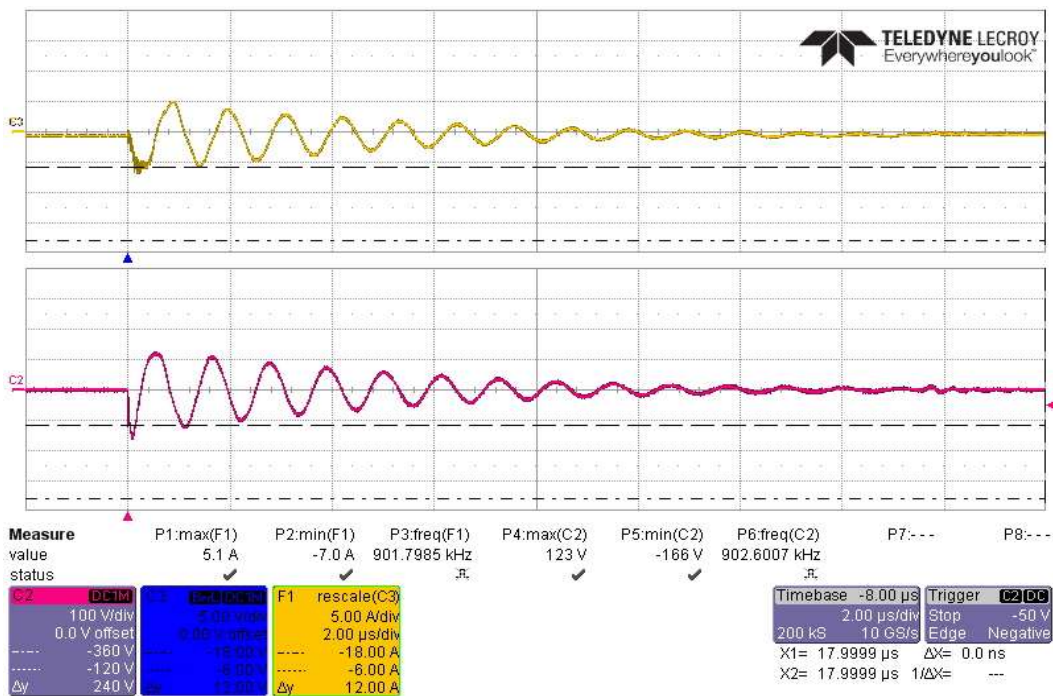

Actual Test CS117 Waveform #3 at 1MHz, First Transient -360V/6A, on Power Line 2

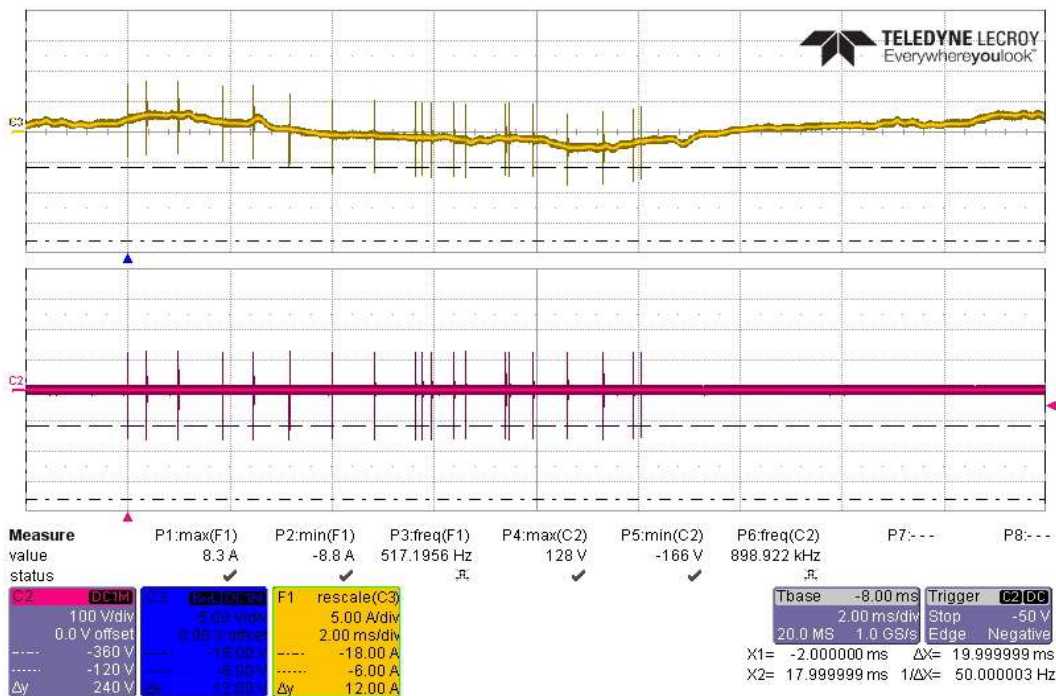

Actual Test CS117 Waveform #3 at 1MHz, 20 Transients -360V/6A, on Power Line 2

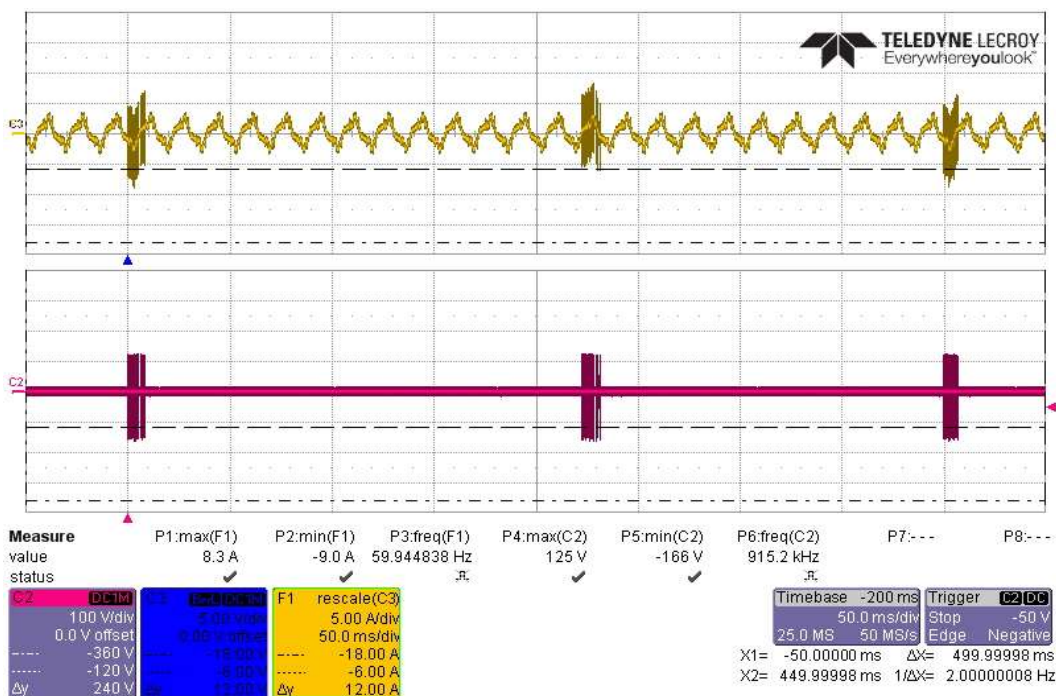

Actual Test CS117 Waveform #3 at 1MHz, 3 Bursts -360V/6A, on Power Line 2

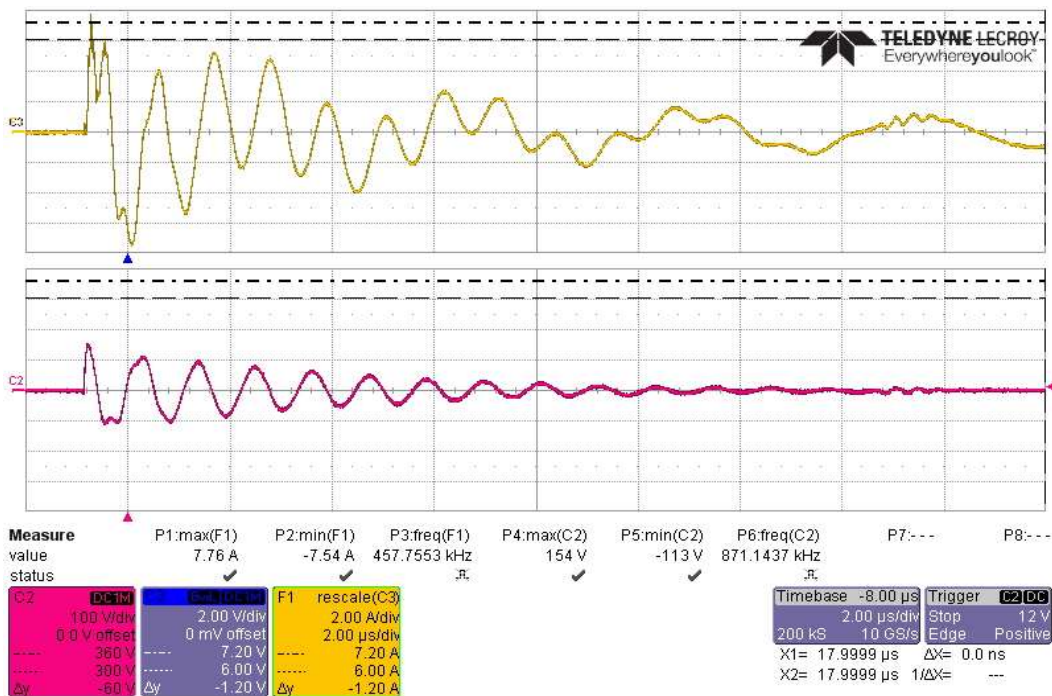

Actual Test CS117 Waveform #3 at 1MHz, First Transient +360V/6A, on Power Lines

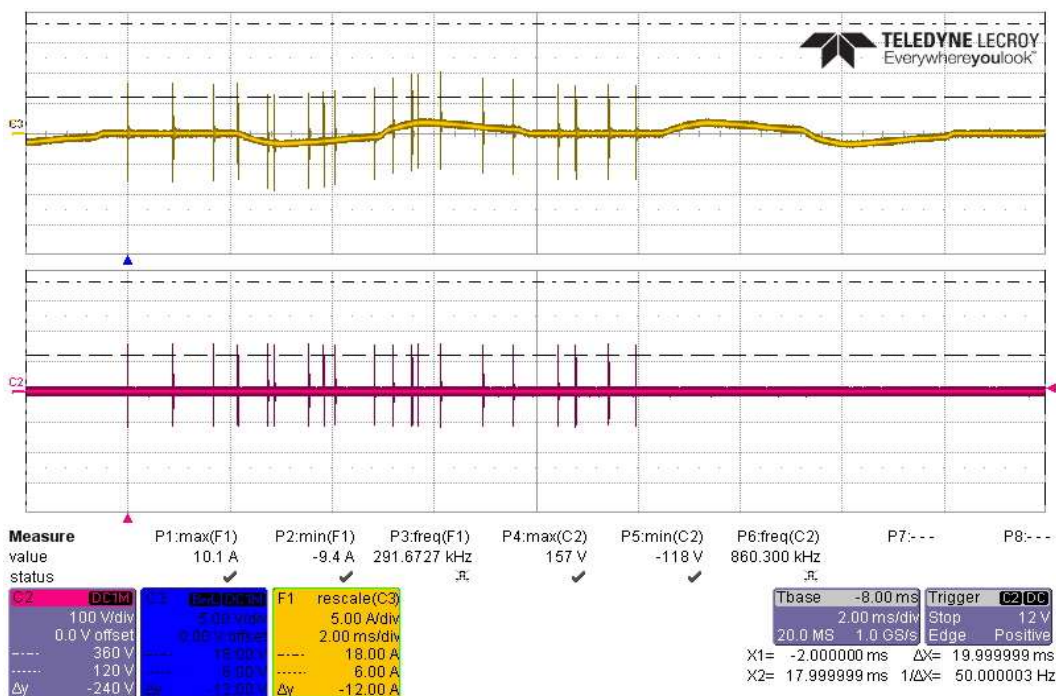

Actual Test CS117 Waveform #3 at 1MHz, 20 Transients +360V/6A, on Power Lines

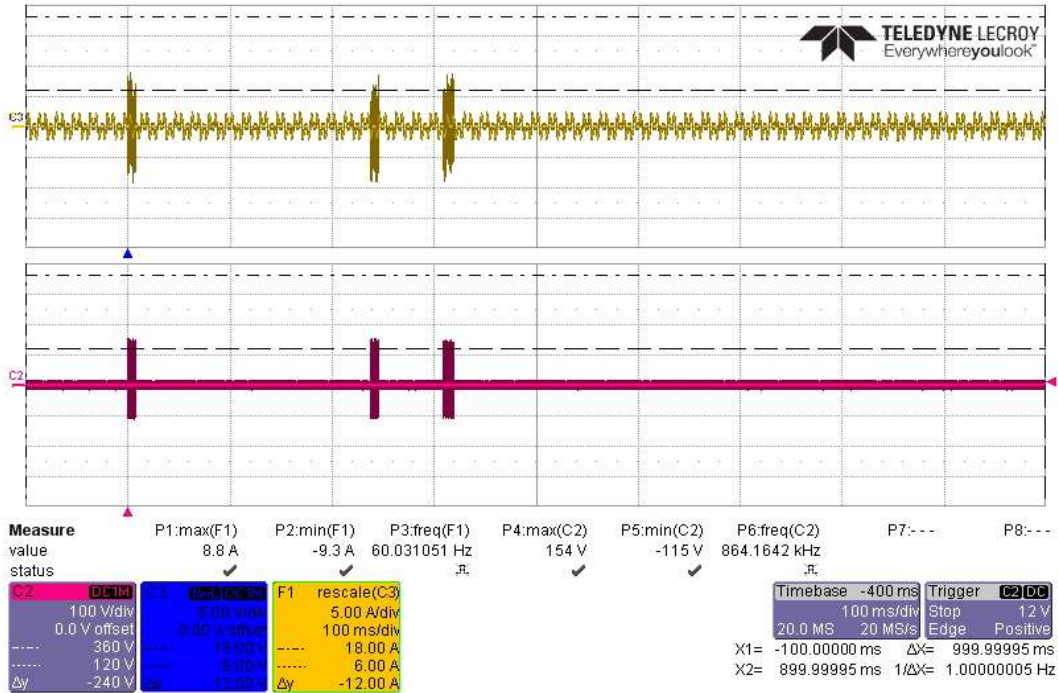

Actual Test CS117 Waveform #3 at 1MHz, 3 Bursts +360V/6A, on Power Lines

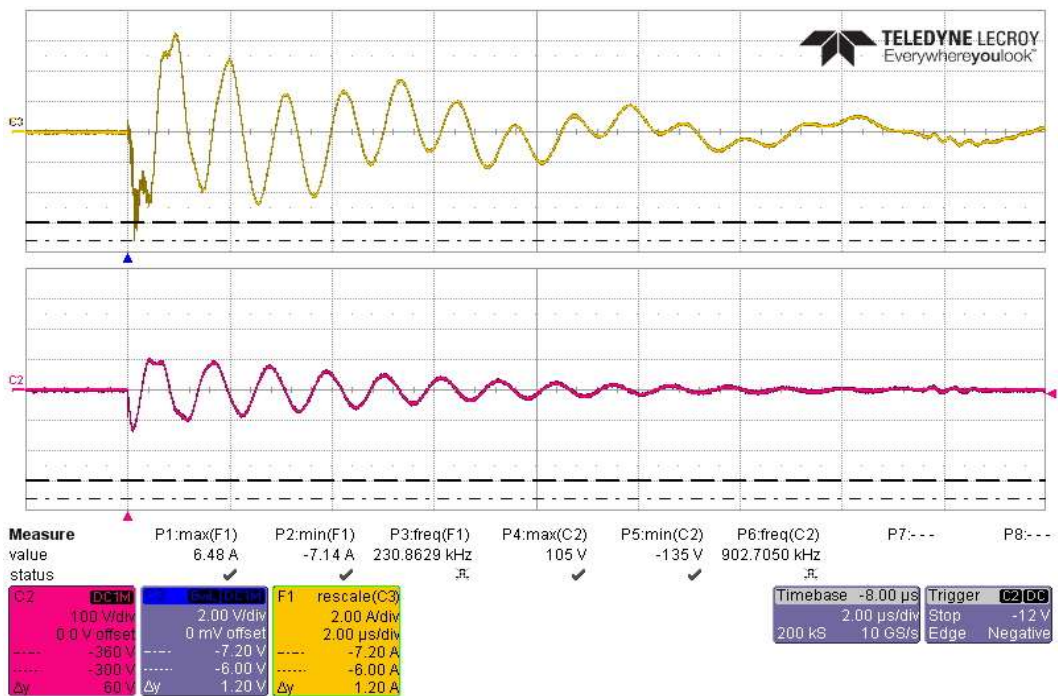

Actual Test CS117 Waveform #3 at 1MHz, First Transient -360V/6A, on Power Lines

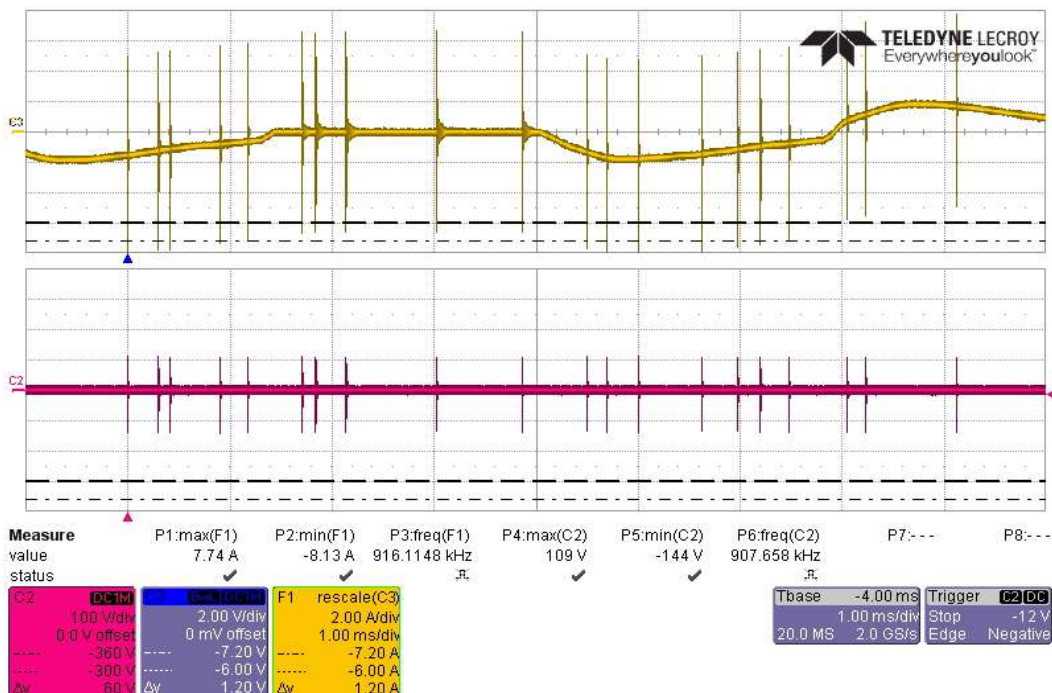

Actual Test CS117 Waveform #3 at 1MHz, 20 Transients -360V/6A, on Power Lines

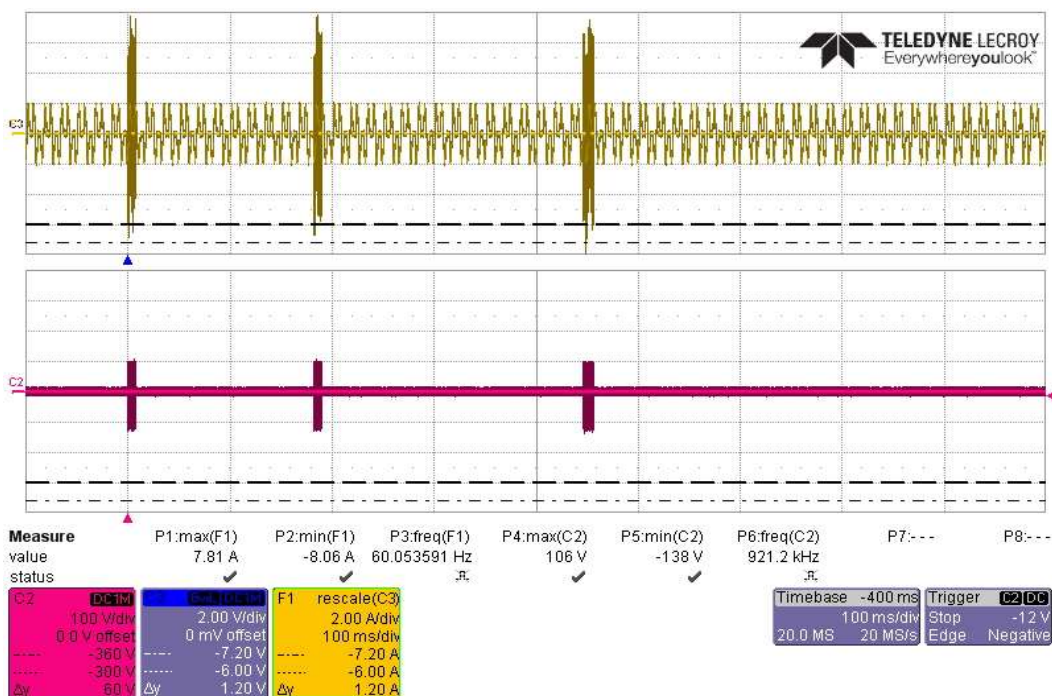

Actual Test CS117 Waveform #3 at 1MHz, 3 Bursts -360V/6A, on Power Lines

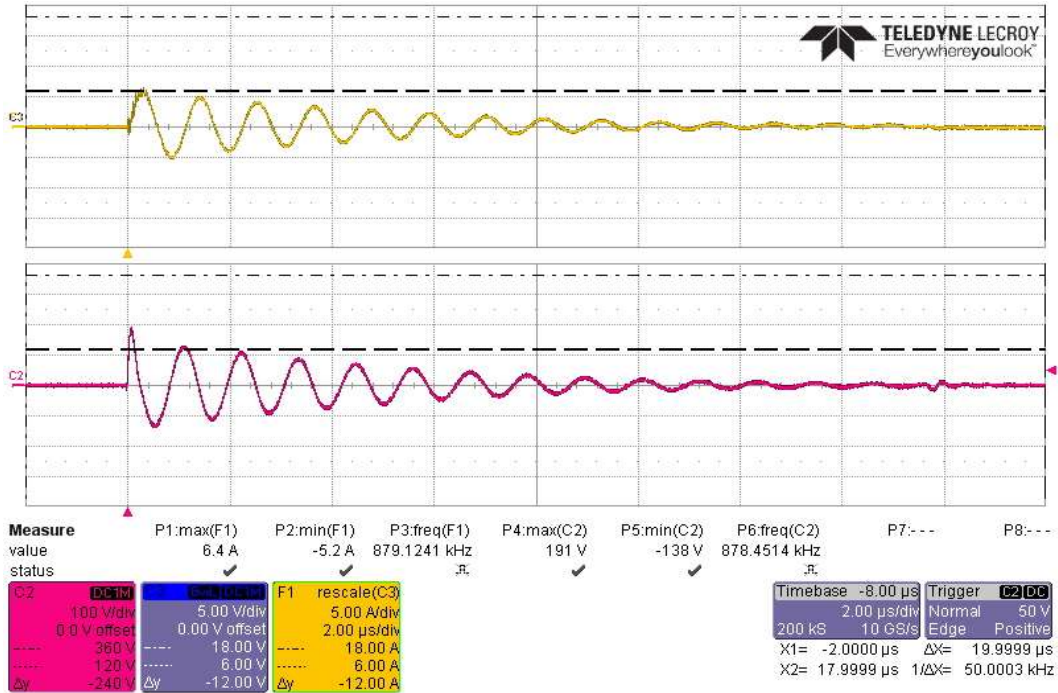

Actual Test CS117 Waveform #3 at 1MHz, First Transient +360V/6A, on Battery High Side

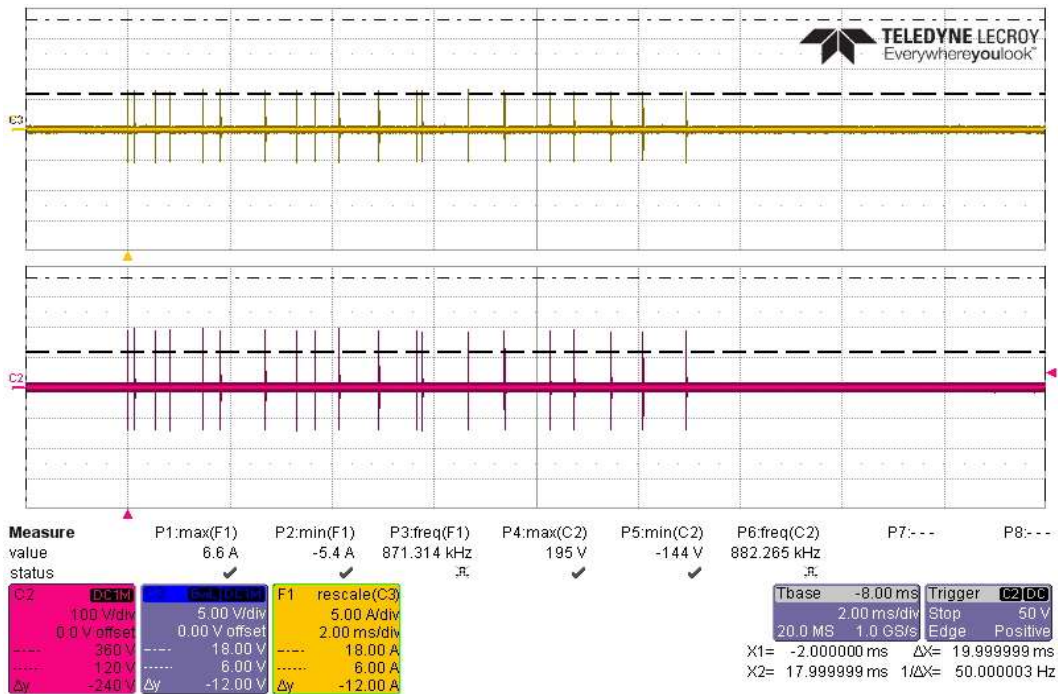

Actual Test CS117 Waveform #3 at 1MHz, 20 Transients +360V/6A, on Battery High Side

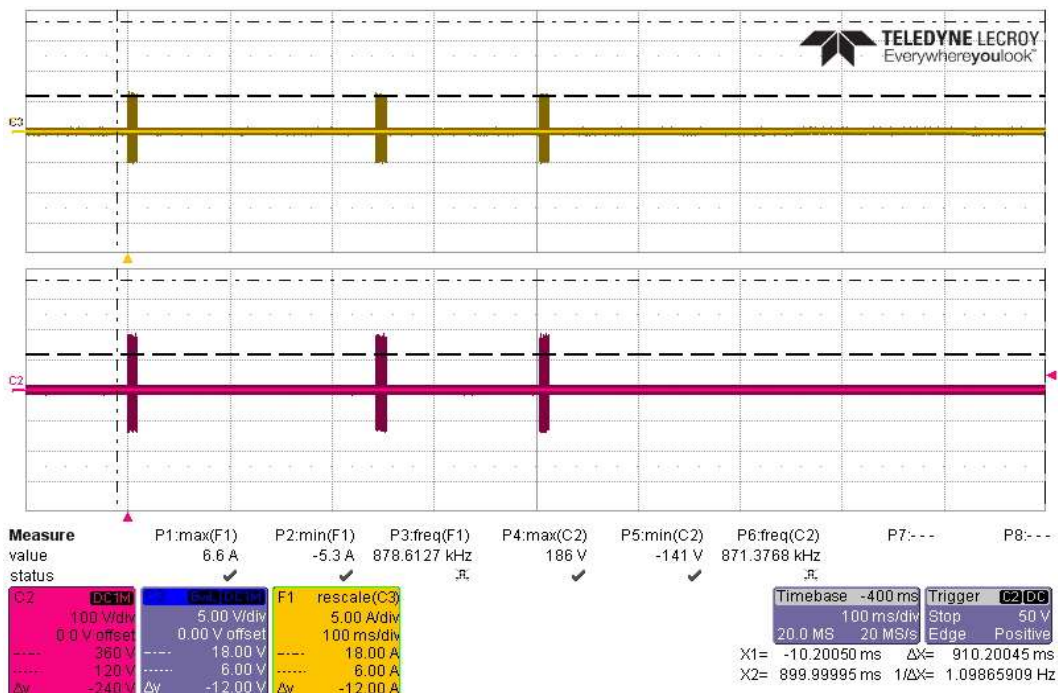

Actual Test CS117 Waveform #3 at 1MHz, 3 Bursts +360V/6A, on Battery High Side

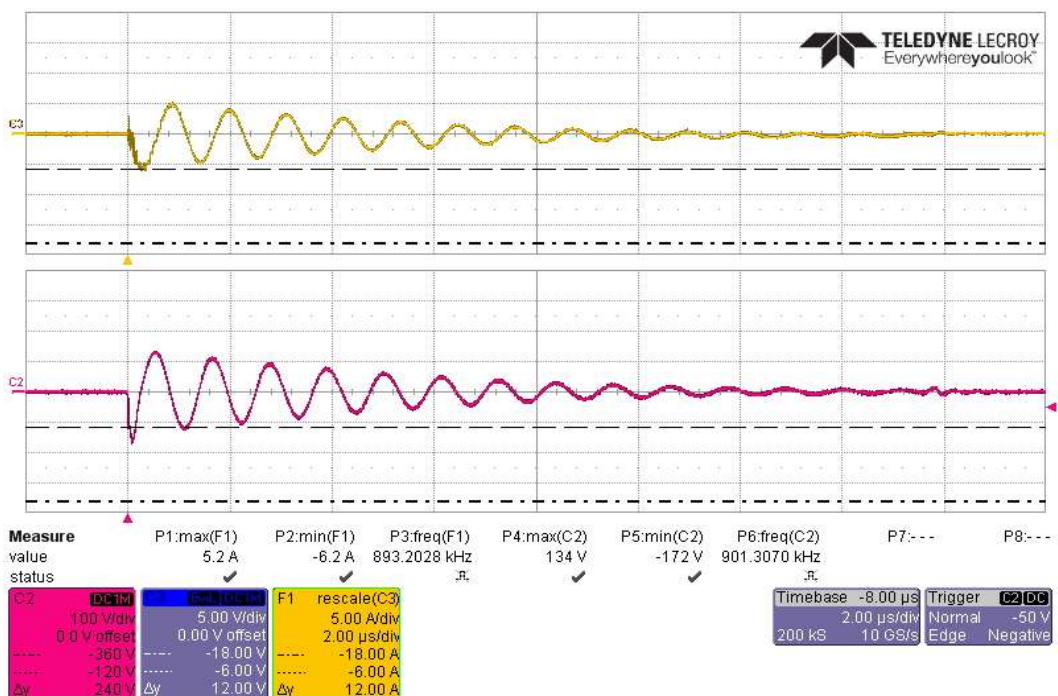

Actual Test CS117 Waveform #3 at 1MHz, First Transient -360V/6A, on Battery High Side

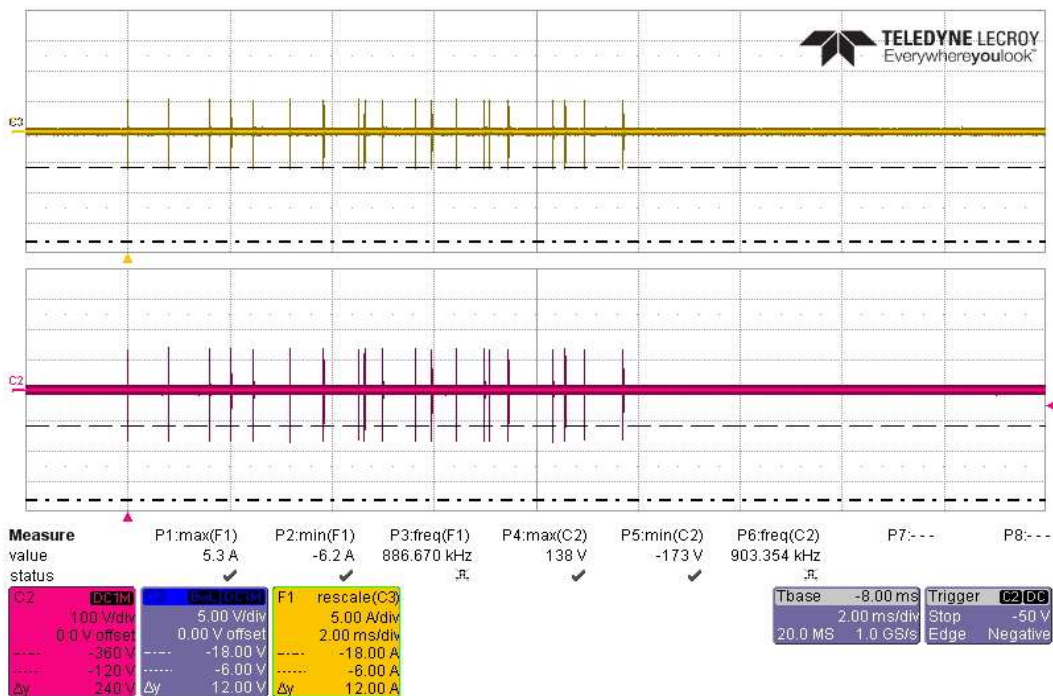

Actual Test CS117 Waveform #3 at 1MHz, 20 Transients -360V/6A, on Battery High Side

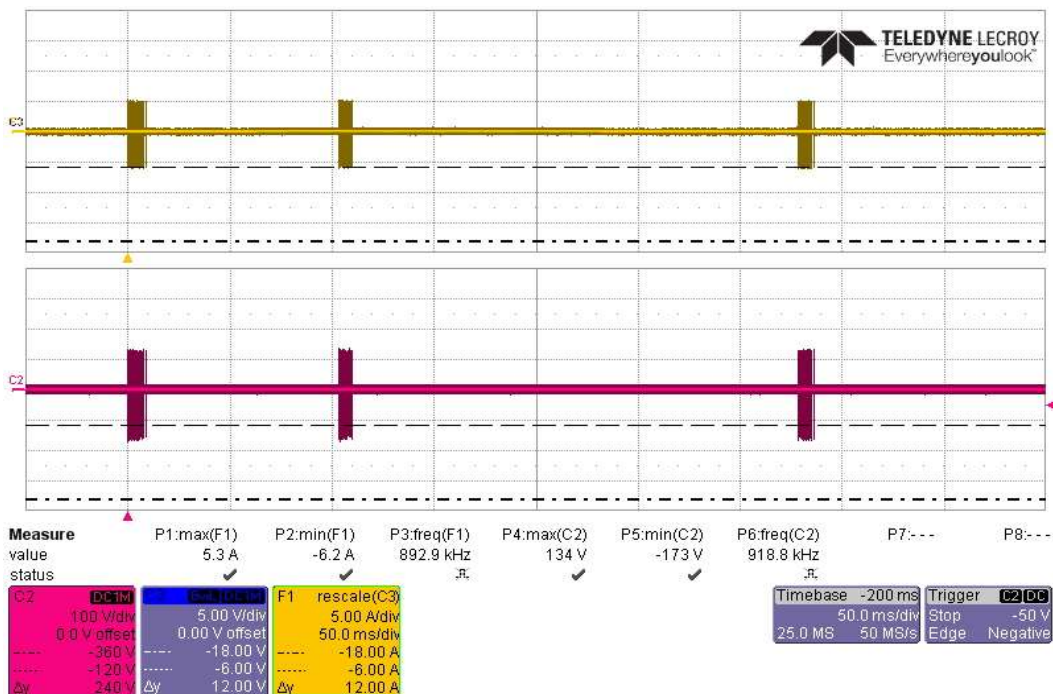

Actual Test CS117 Waveform #3 at 1MHz, 3 Bursts -360V/6A, on Battery High Side

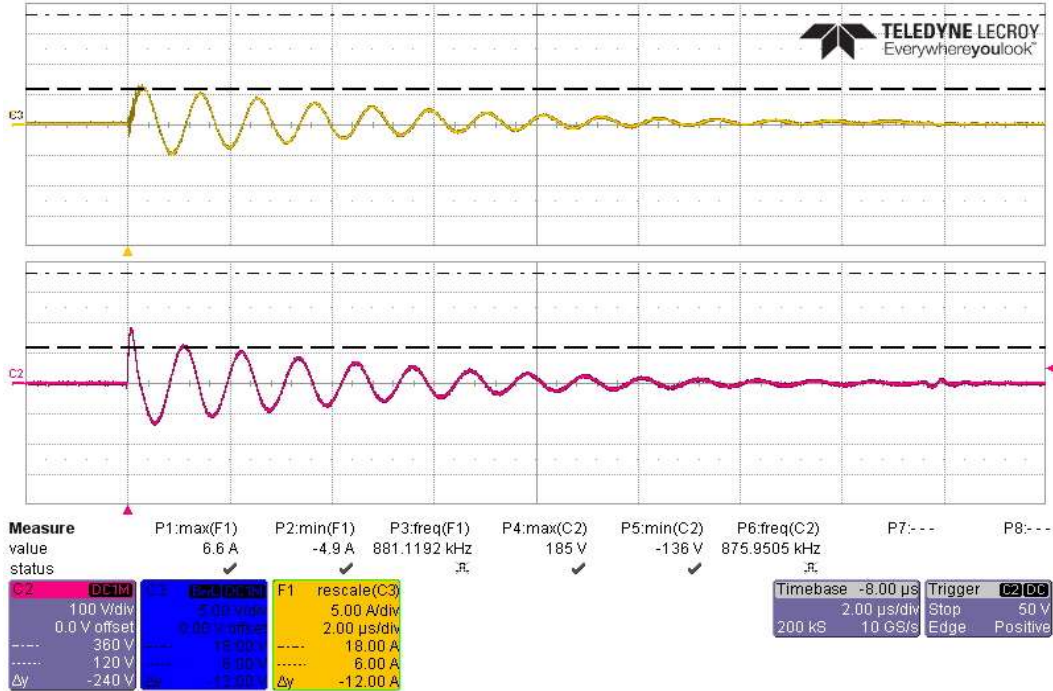

Actual Test CS117 Waveform #3 at 1MHz, First Transient +360V/6A, on Battery Return Side

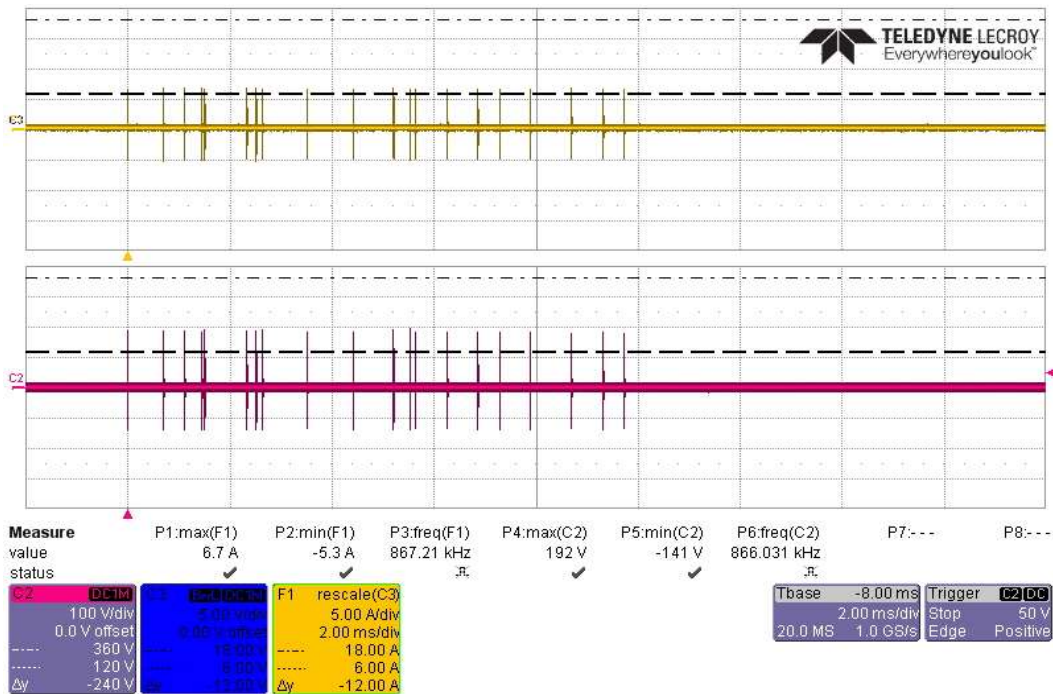

Actual Test CS117 Waveform #3 at 1MHz, 20 Transients +360V/6A, on Battery Return Side

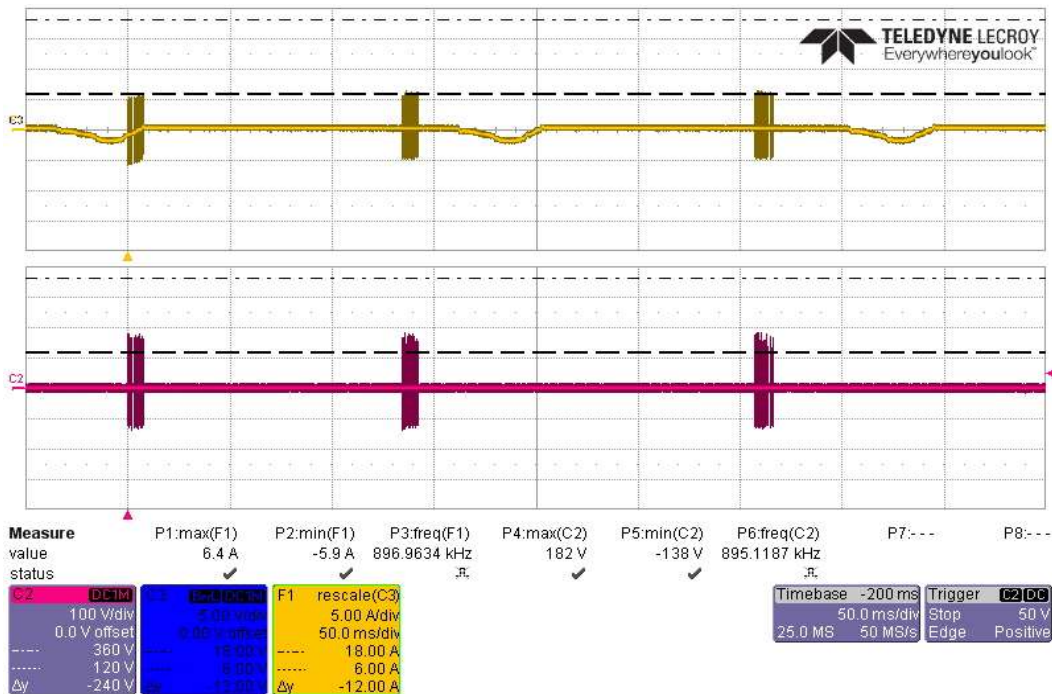

Actual Test CS117 Waveform #3 at 1MHz, 3 Bursts +360V/6A, on Battery Return Side

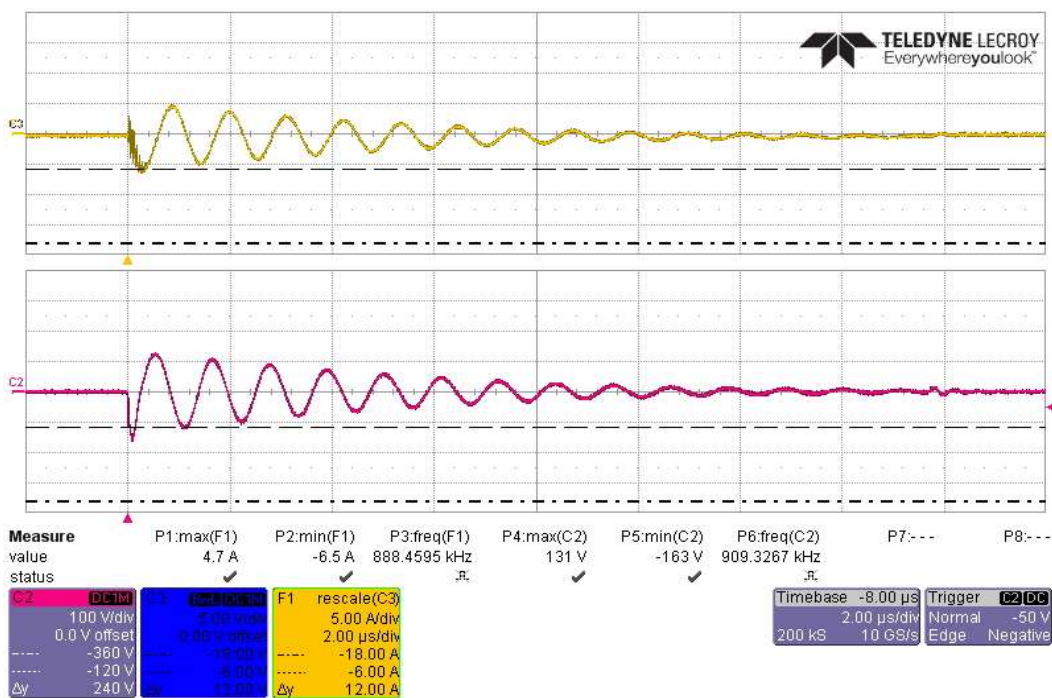

Actual Test CS117 Waveform #3 at 1MHz, First Transient -360V/6A, on Battery Return Side

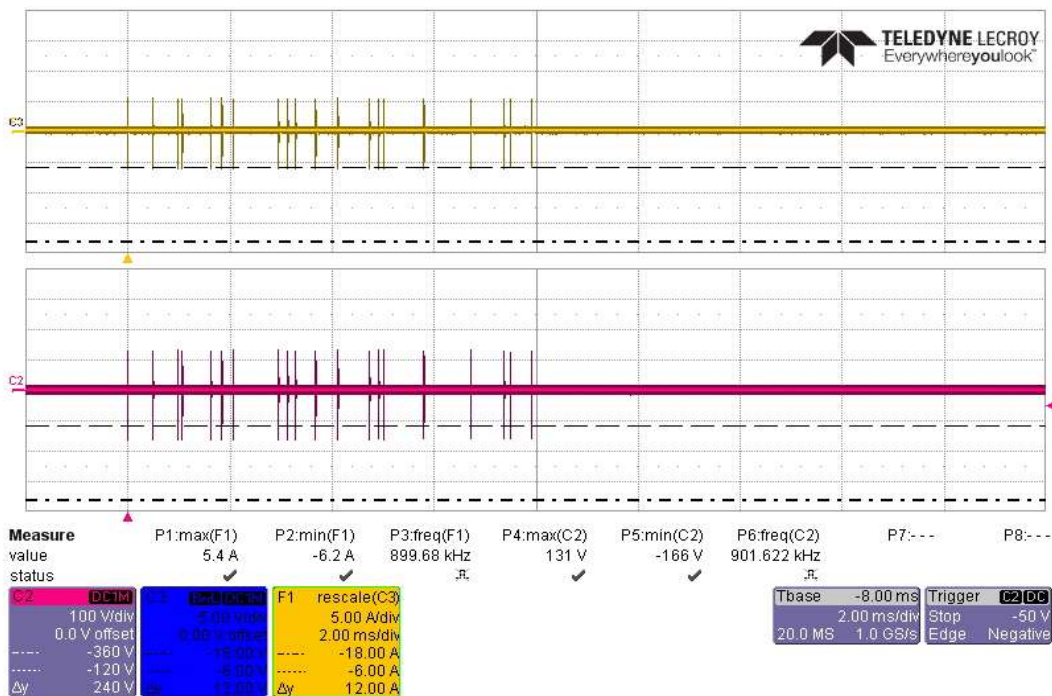

Actual Test CS117 Waveform #3 at 1MHz, 20 Transients -360V/6A, on Battery Return Side

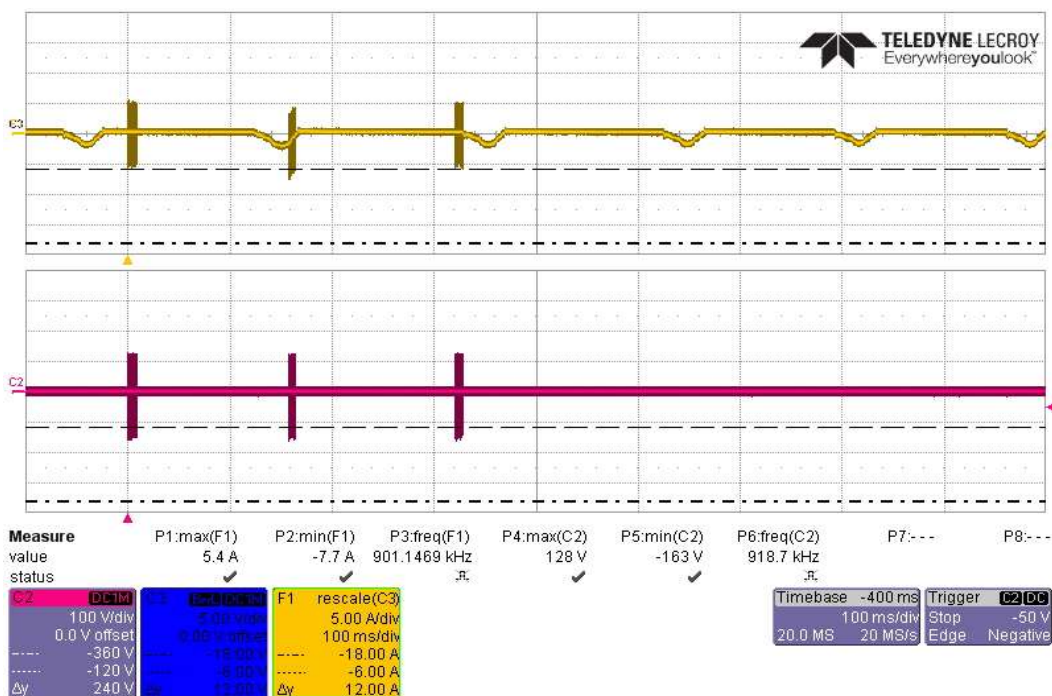

Actual Test CS117 Waveform #3 at 1MHz, 3 Bursts -360V/6A, on Battery Return Side

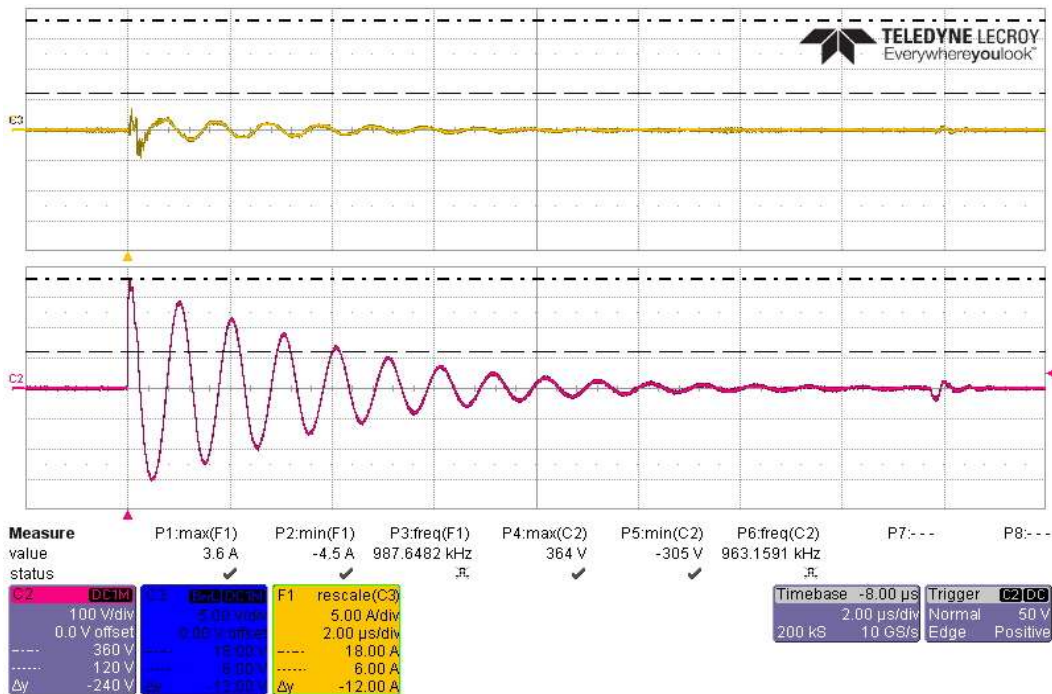

Actual Test CS117 Waveform #3 at 1MHz, First Transient +360V/6A, on Battery Bundle

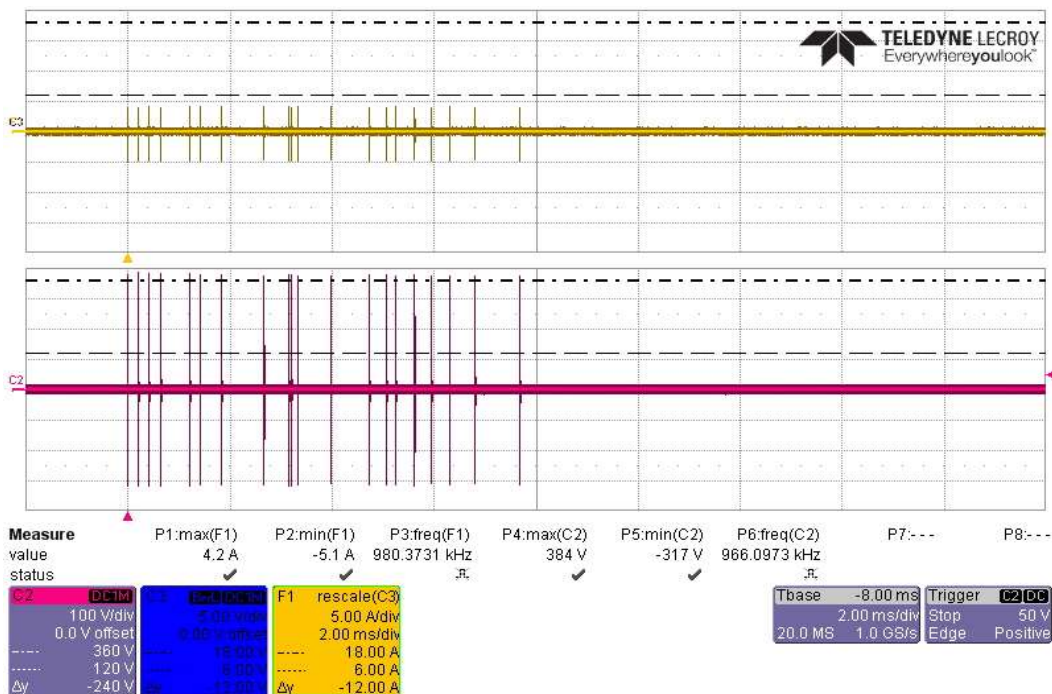

Actual Test CS117 Waveform #3 at 1MHz, 20 Transients +360V/6A, on Battery Bundle

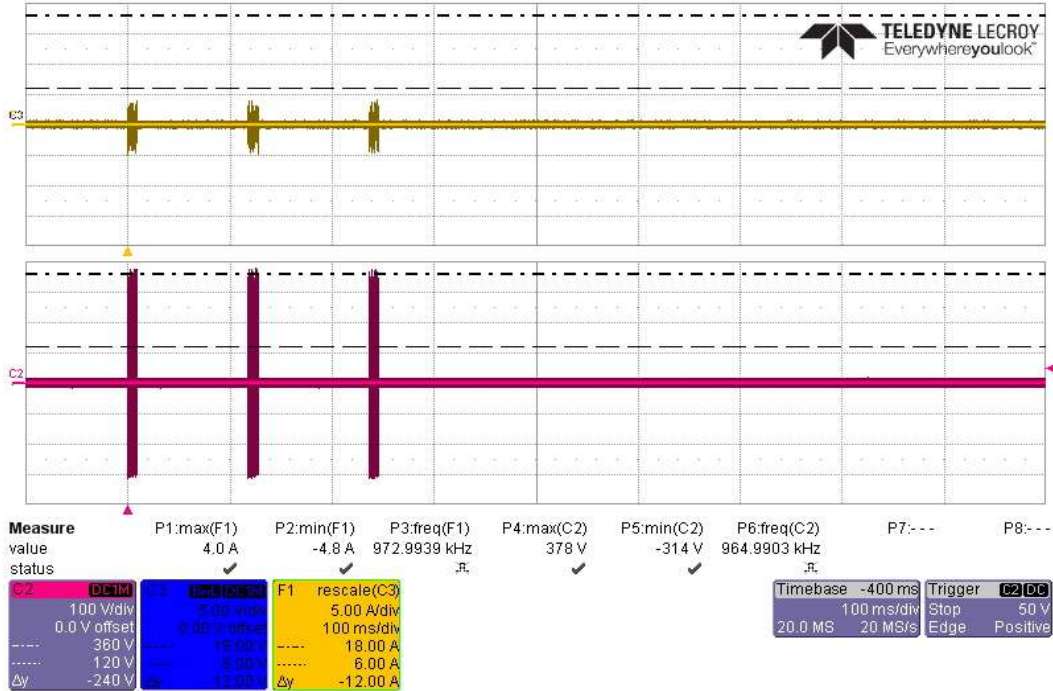

Actual Test CS117 Waveform #3 at 1MHz, 3 Bursts +360V/6A, on Battery Bundle

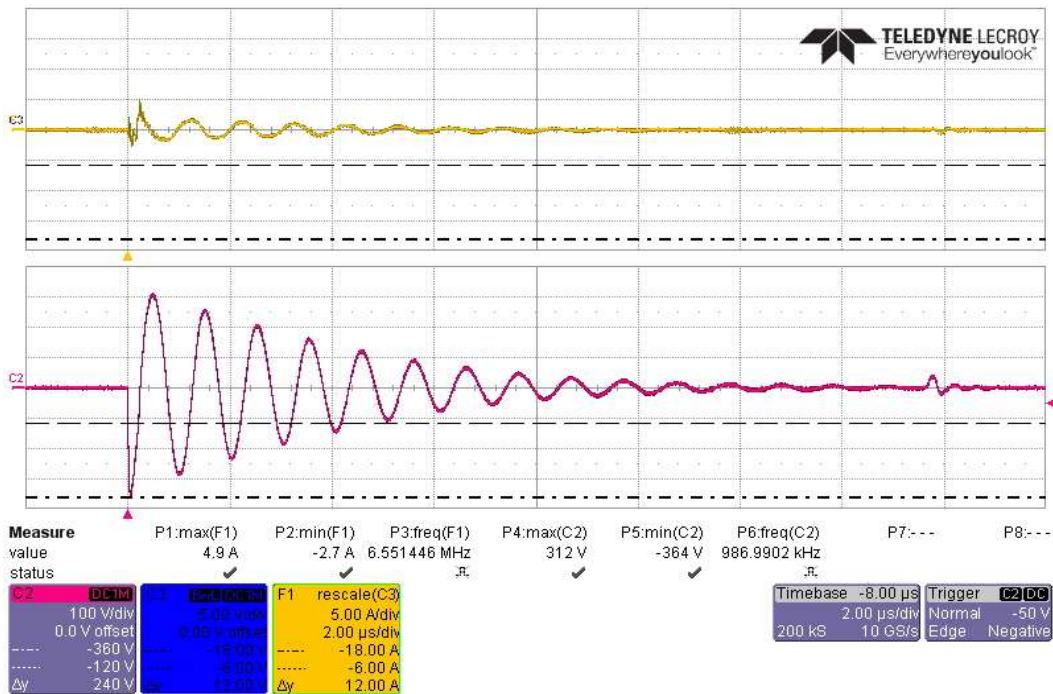

Actual Test CS117 Waveform #3 at 1MHz, First Transient -360V/6A, on Battery Bundle

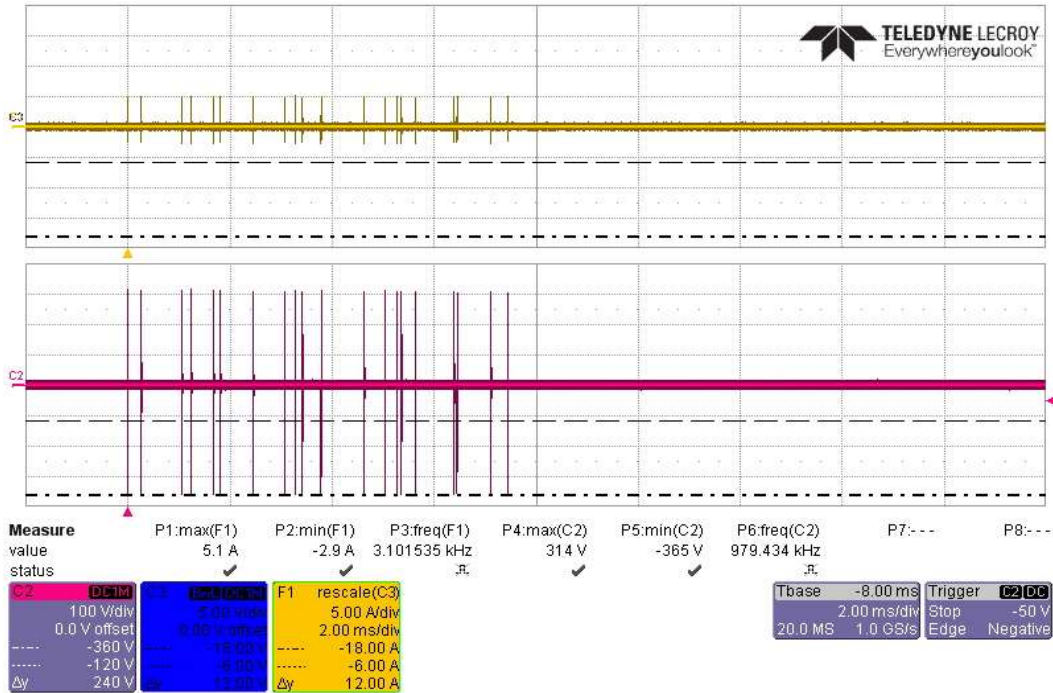

Actual Test CS117 Waveform #3 at 1MHz, 20 Transients -360V/6A, on Battery Bundle

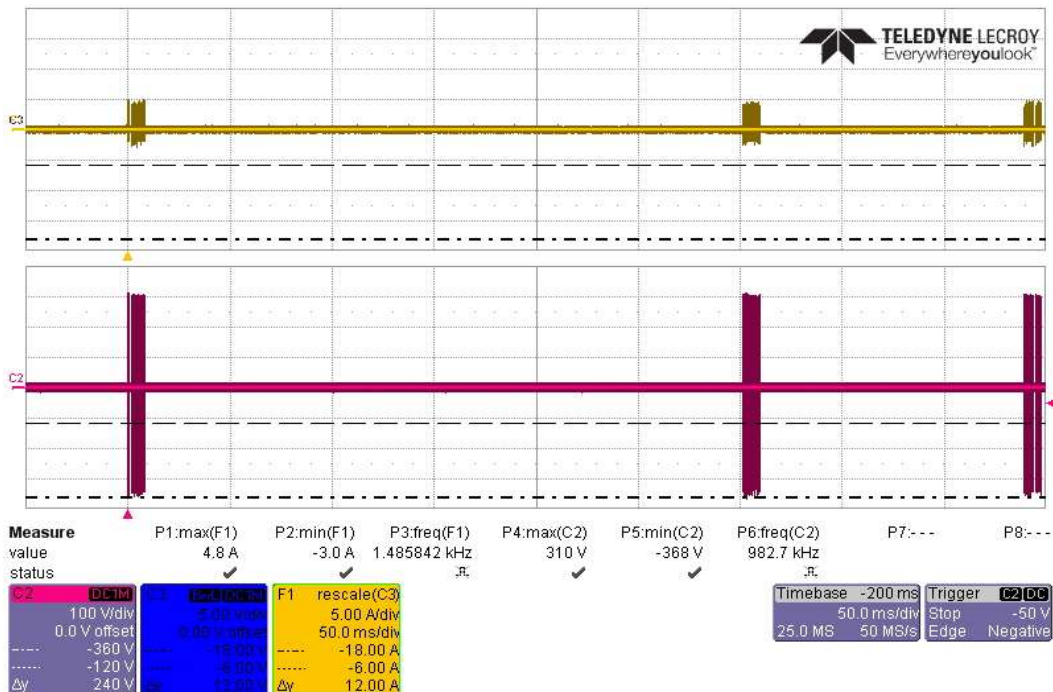

Actual Test CS117 Waveform #3 at 1MHz, 3 Bursts -360V/6A, on Battery Bundle

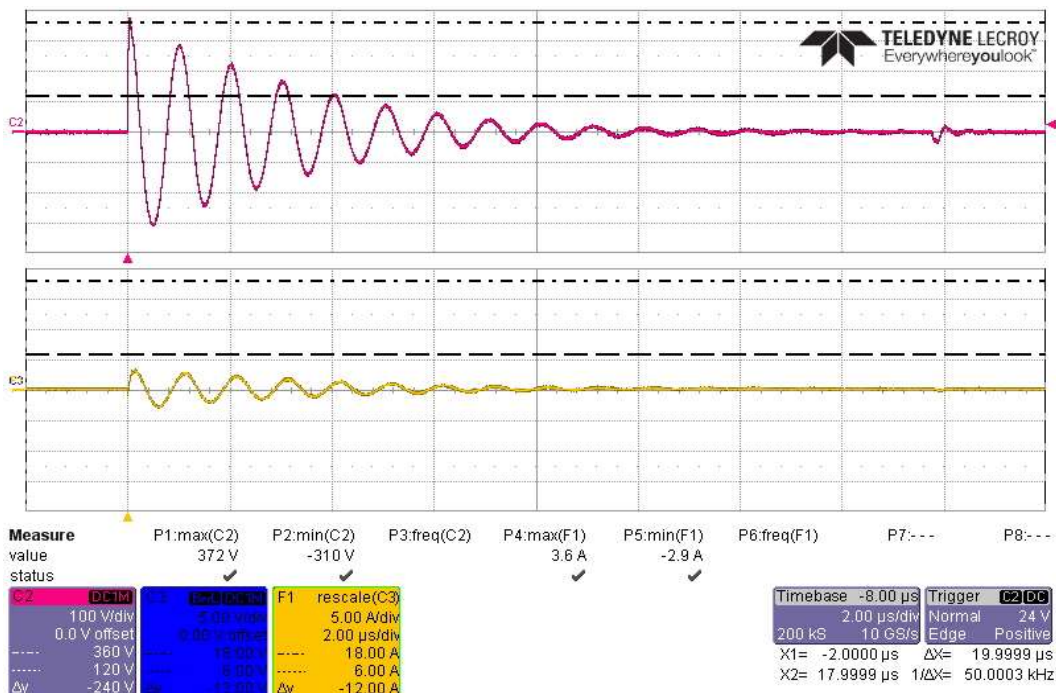

Actual Test CS117 Waveform #3 at 1MHz, First Transient +360V/6A, on PV High Side

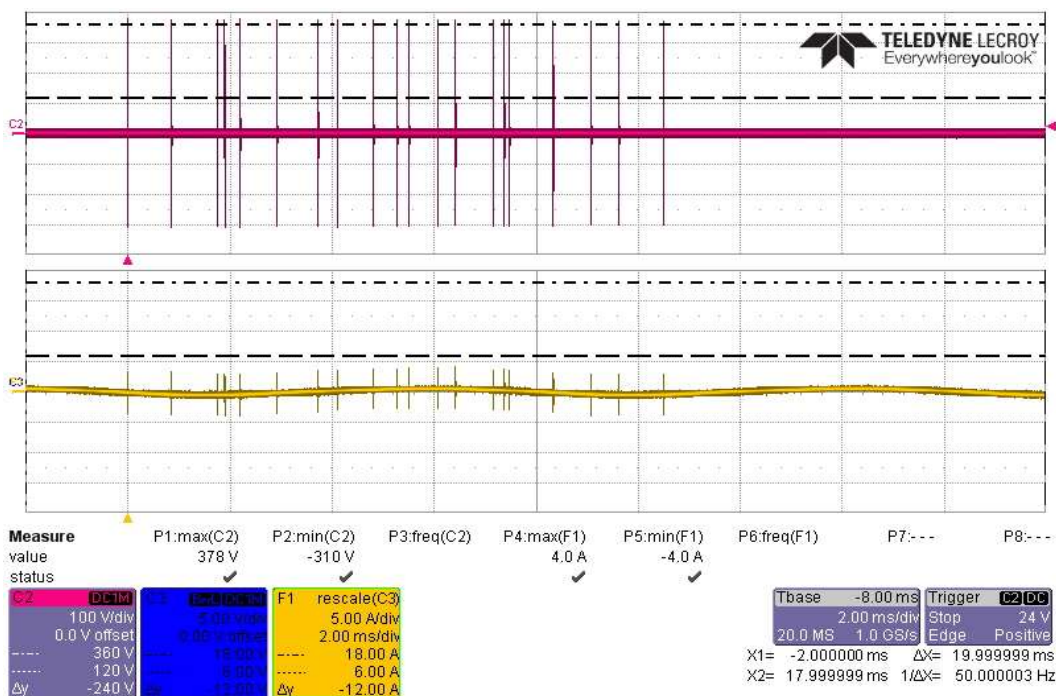

Actual Test CS117 Waveform #3 at 1MHz, 20 Transients +360V/6A, on PV High Side

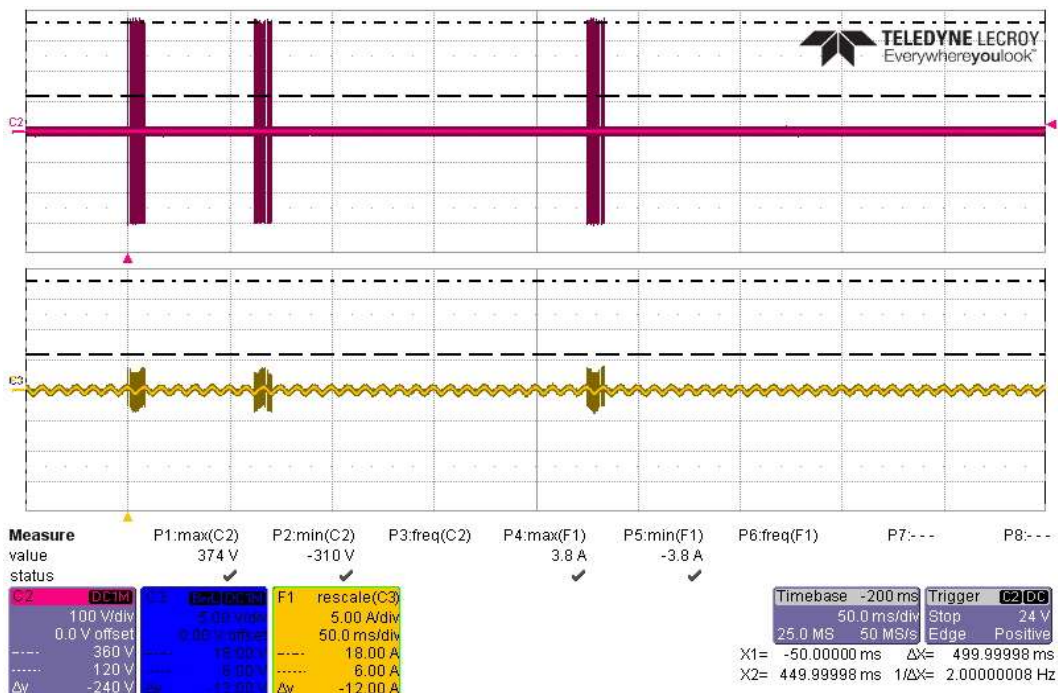

Actual Test CS117 Waveform #3 at 1MHz, 3 Bursts +360V/6A, on PV High Side

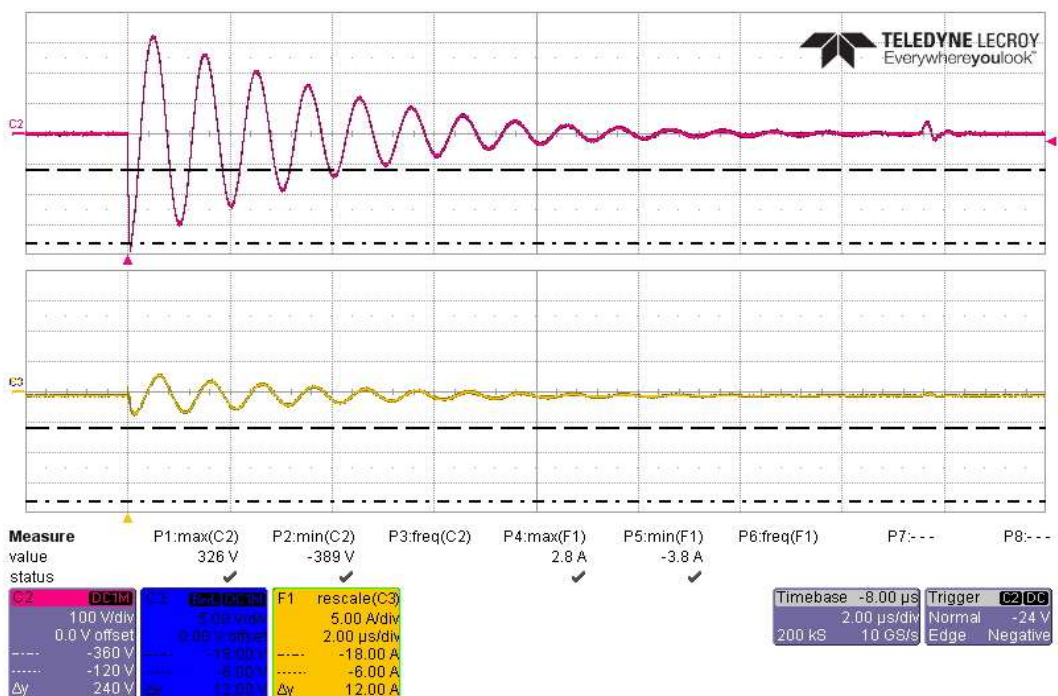

Actual Test CS117 Waveform #3 at 1MHz, First Transient -360V/6A, on PV High Side

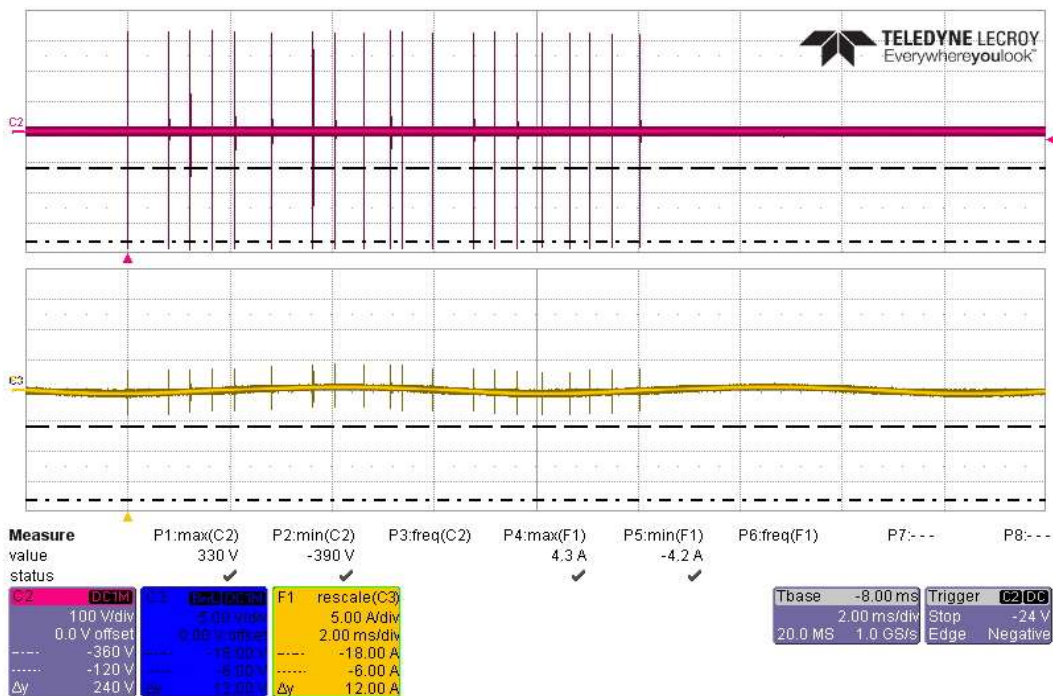

Actual Test CS117 Waveform #3 at 1MHz, 20 Transients -360V/6A, on PV High Side

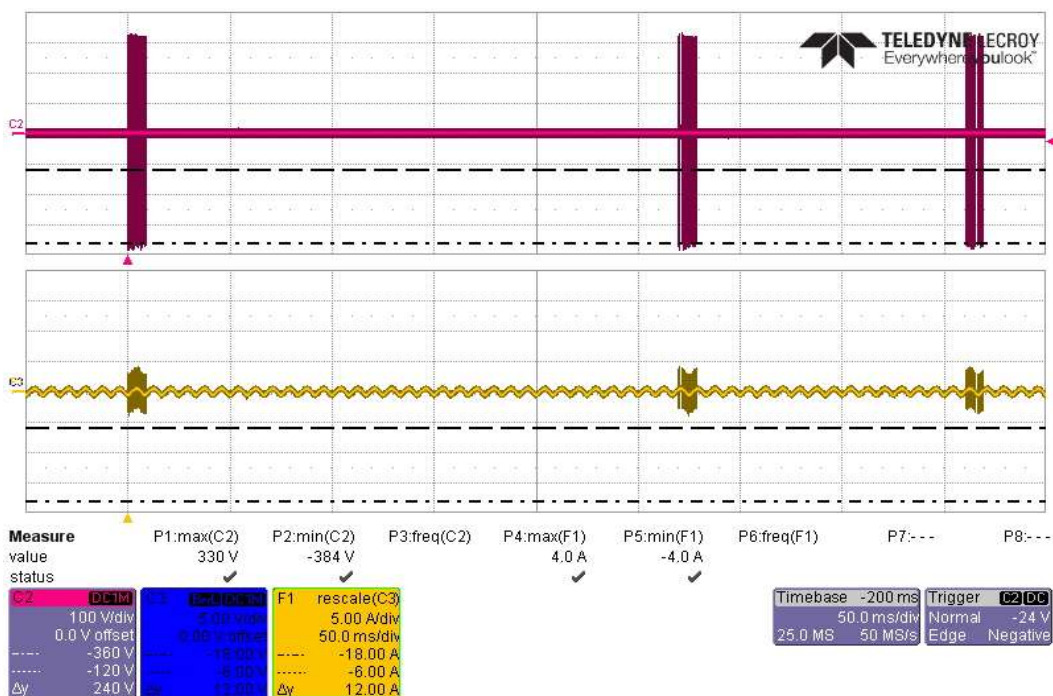

Actual Test CS117 Waveform #3 at 1MHz, 3 Bursts -360V/6A, on PV High Side

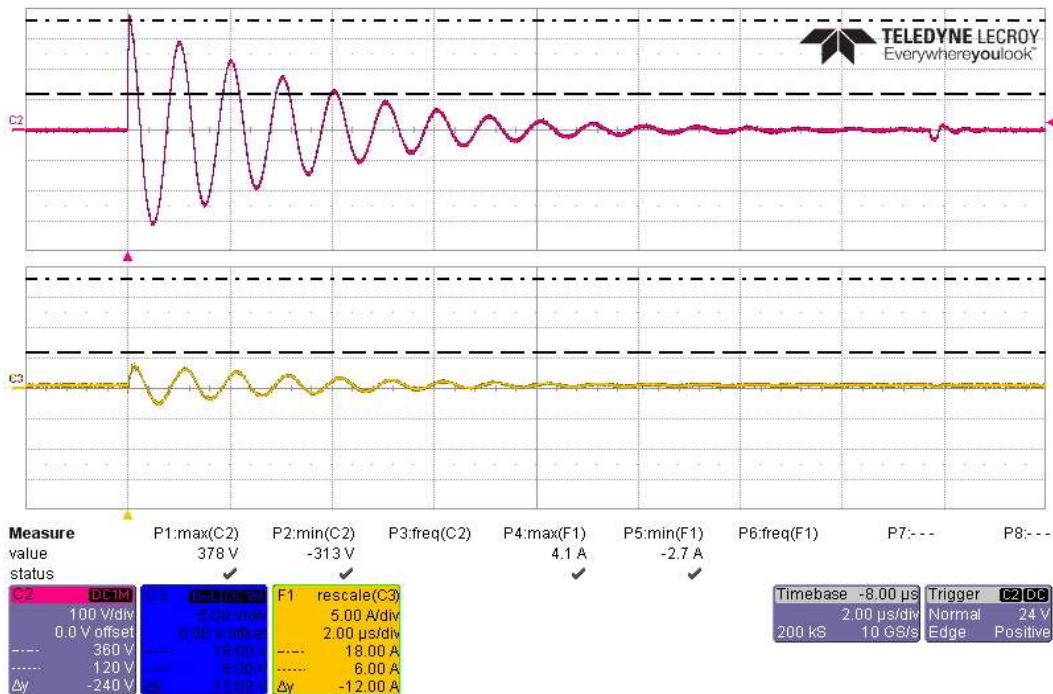

Actual Test CS117 Waveform #3 at 1MHz, First Transient +360V/6A, on PV Return Side

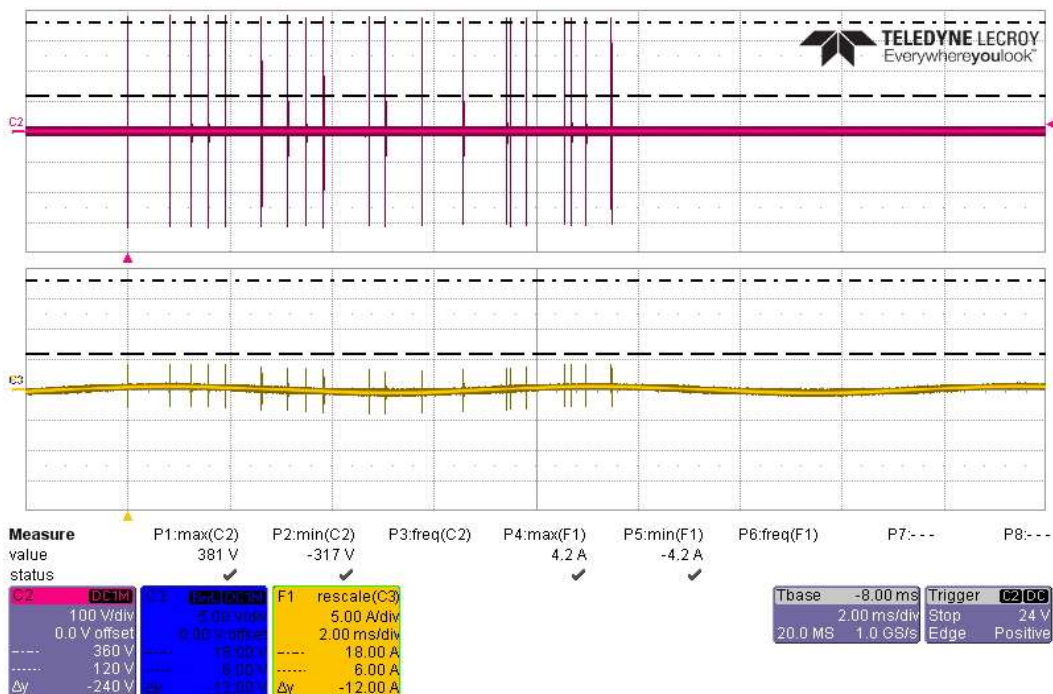

Actual Test CS117 Waveform #3 at 1MHz, 20 Transients +360V/6A, on PV Return Side

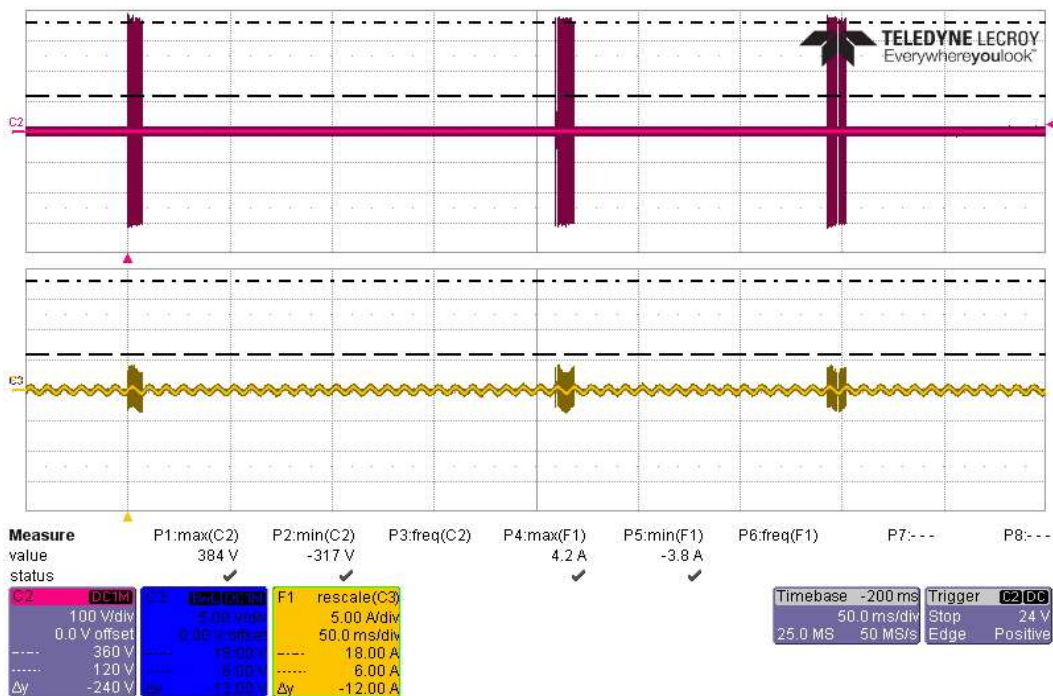

Actual Test CS117 Waveform #3 at 1MHz, 3 Bursts +360V/6A, on PV Return Side

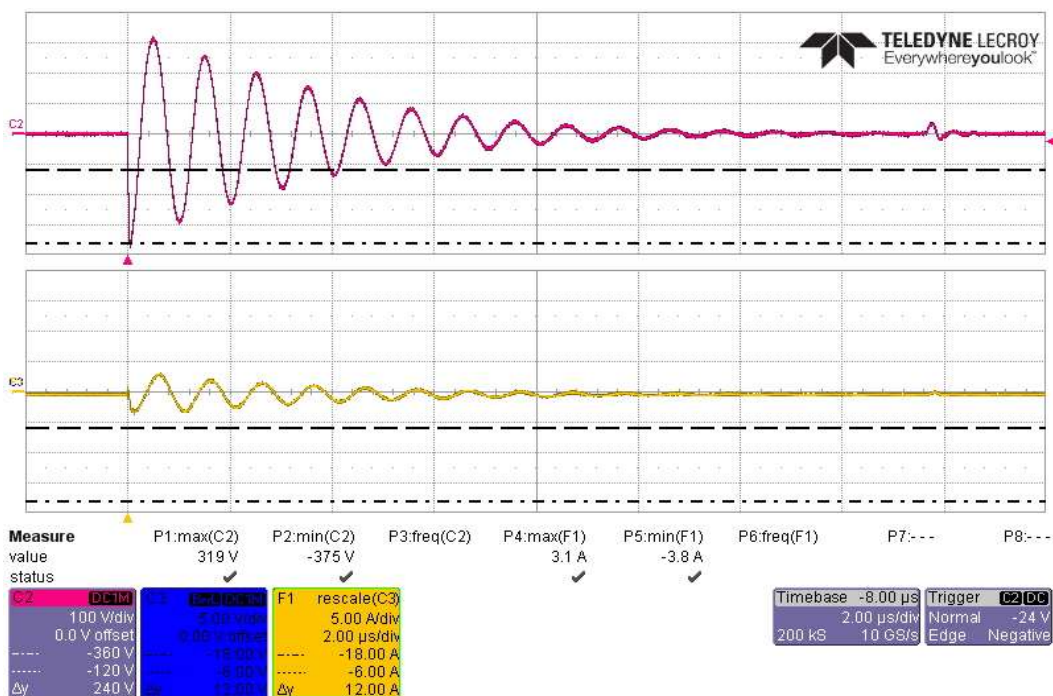

Actual Test CS117 Waveform #3 at 1MHz, First Transient -360V/6A, on PV Return Side

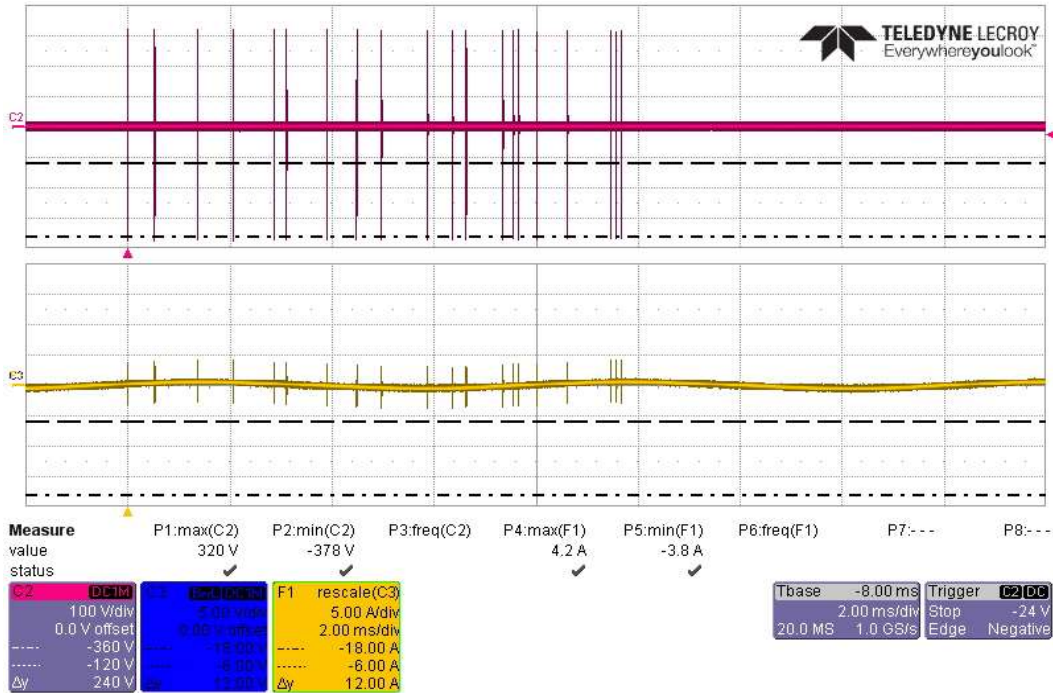

Actual Test CS117 Waveform #3 at 1MHz, 20 Transients -360V/6A, on PV Return Side

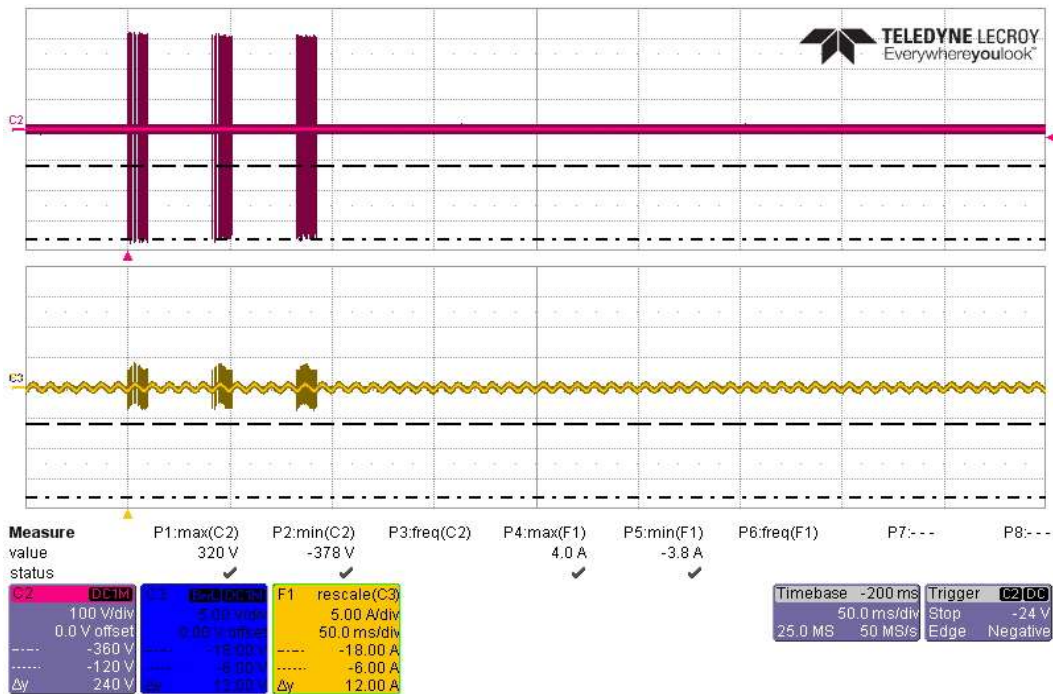

Actual Test CS117 Waveform #3 at 1MHz, 3 Bursts -360V/6A, on PV Return Side

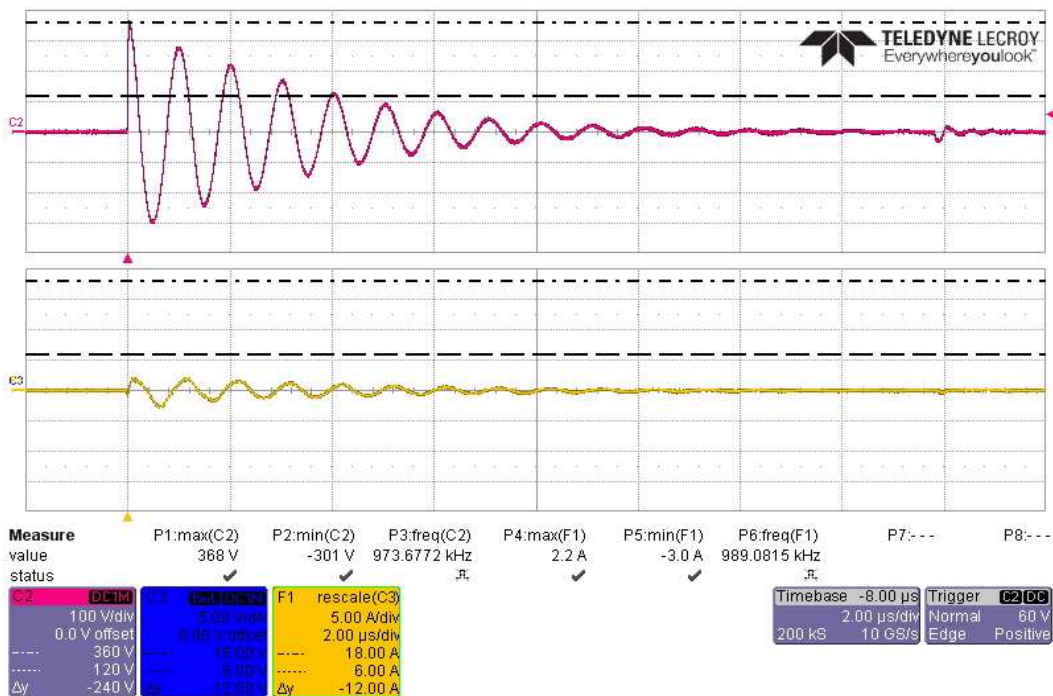

Actual Test CS117 Waveform #3 at 1MHz, First Transient +360V/6A, on PV Bundle

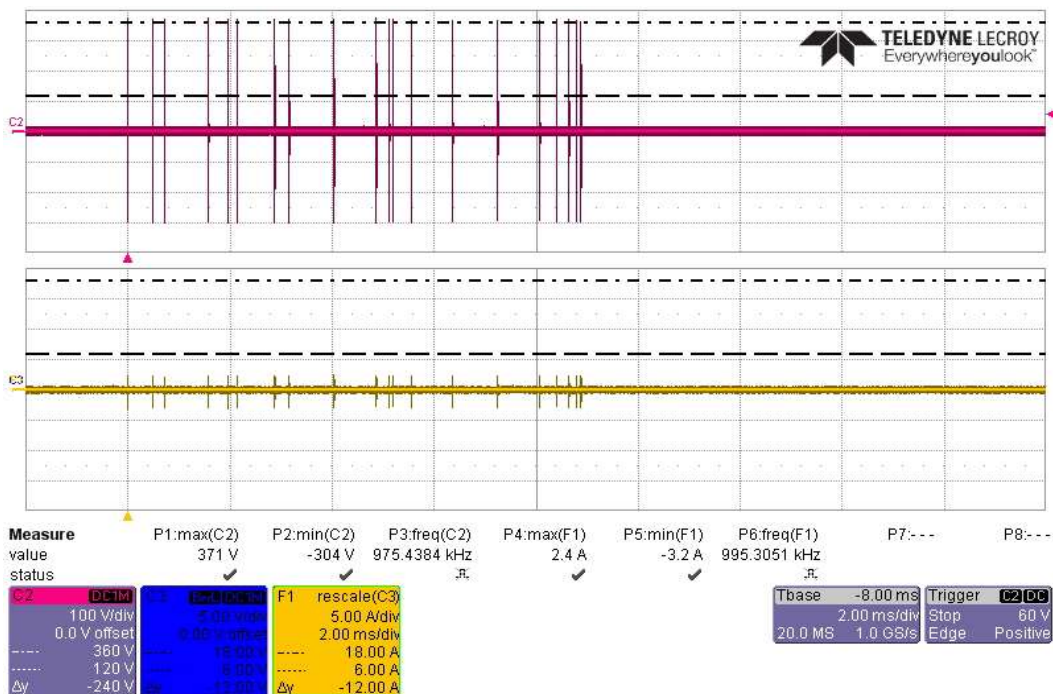

Actual Test CS117 Waveform #3 at 1MHz, 20 Transients +360V/6A, on PV Bundle

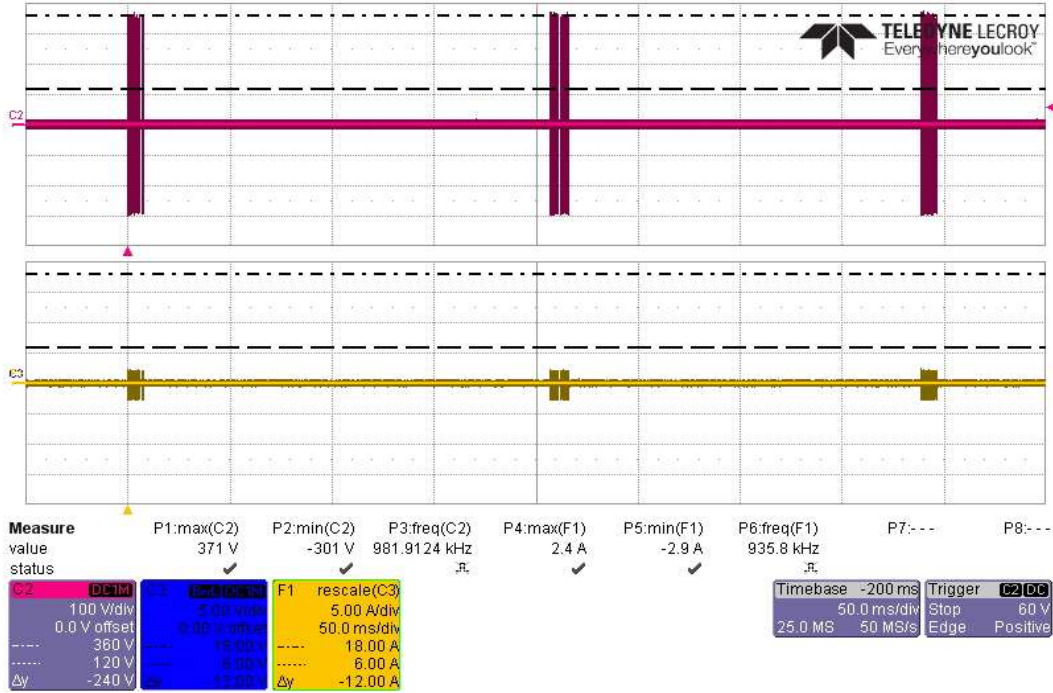

Actual Test CS117 Waveform #3 at 1MHz, 3 Bursts +360V/6A, on PV Bundle

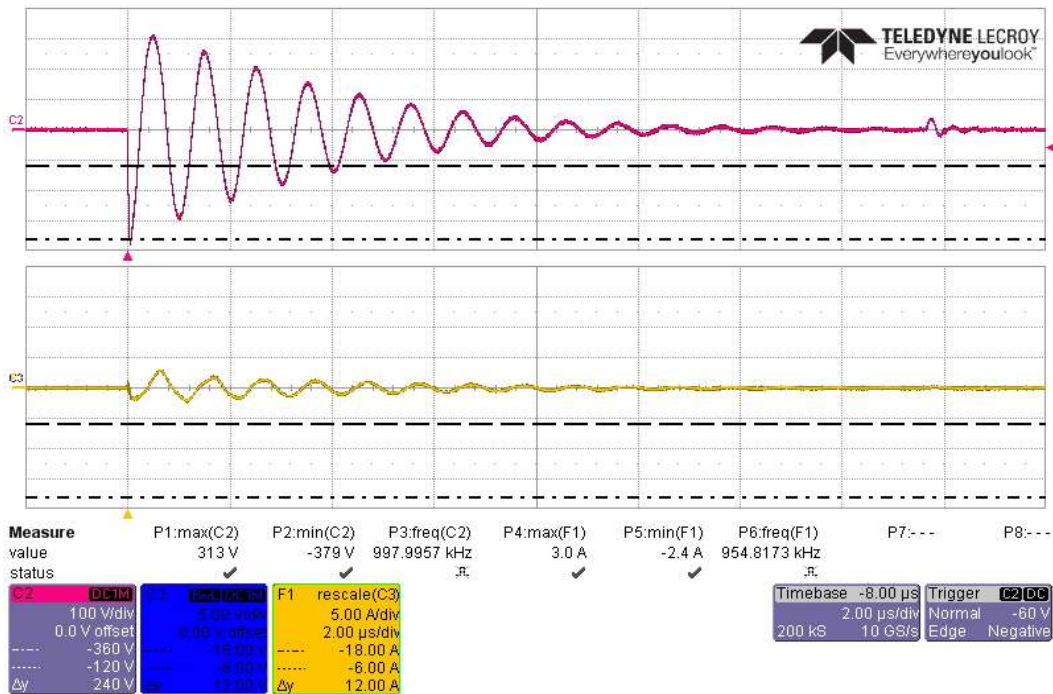

Actual Test CS117 Waveform #3 at 1MHz, First Transient -360V/6A, on PV Bundle

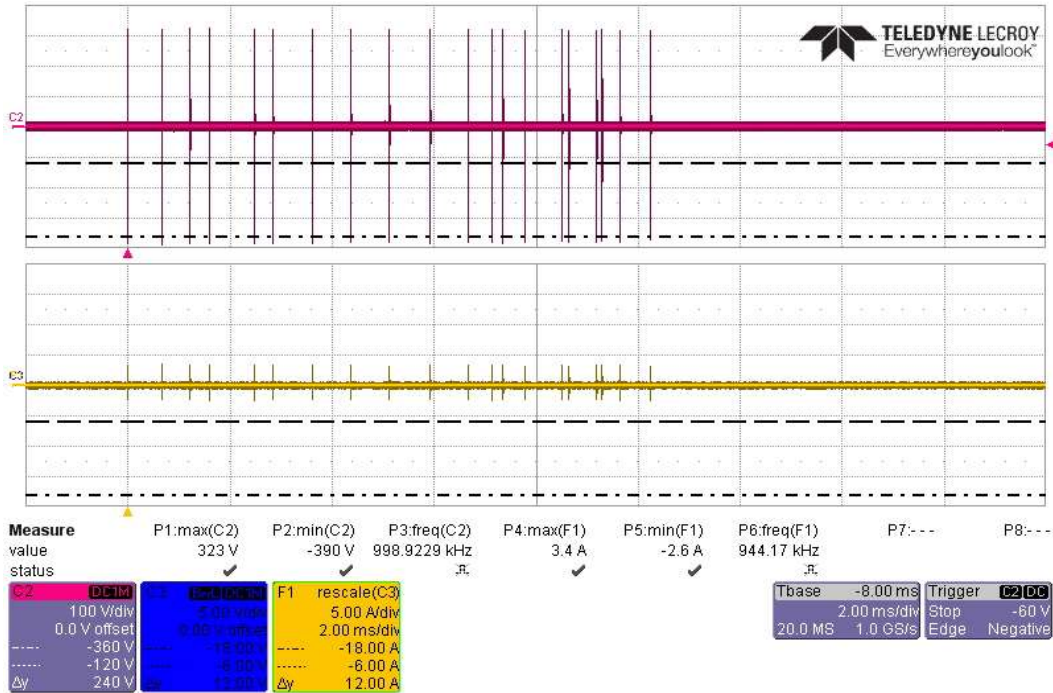

Actual Test CS117 Waveform #3 at 1MHz, 20 Transients -360V/6A, on PV Bundle

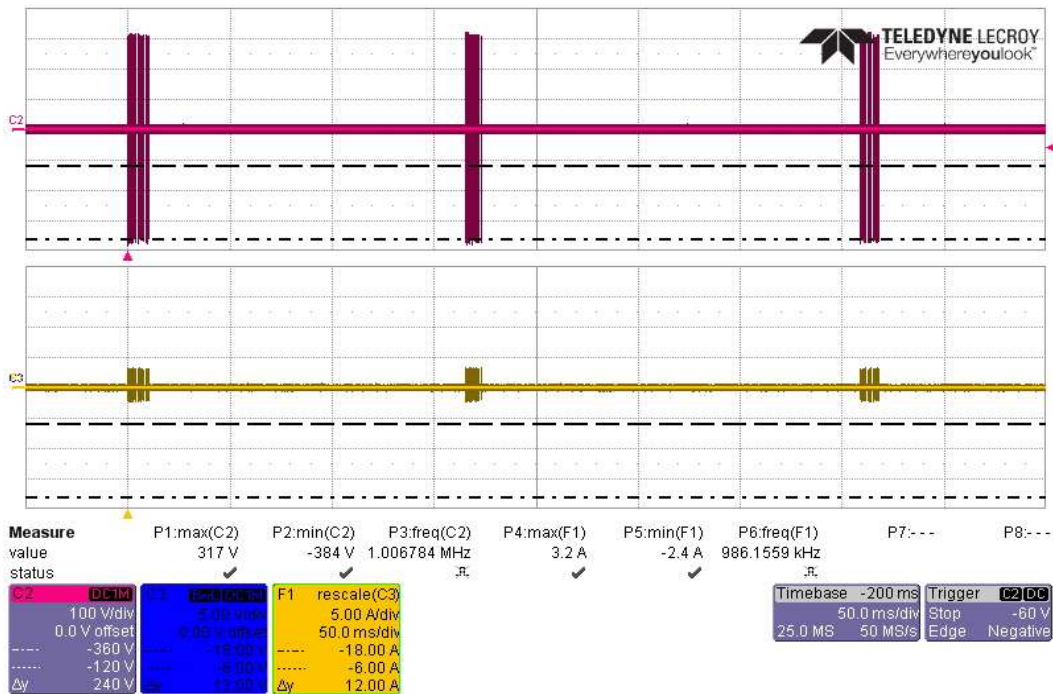

Actual Test CS117 Waveform #3 at 1MHz, 3 Bursts -360V/6A, on PV Bundle

CS117 Actual Test Multiple Burst Waveform #3 at 10MHz with 360V/6A

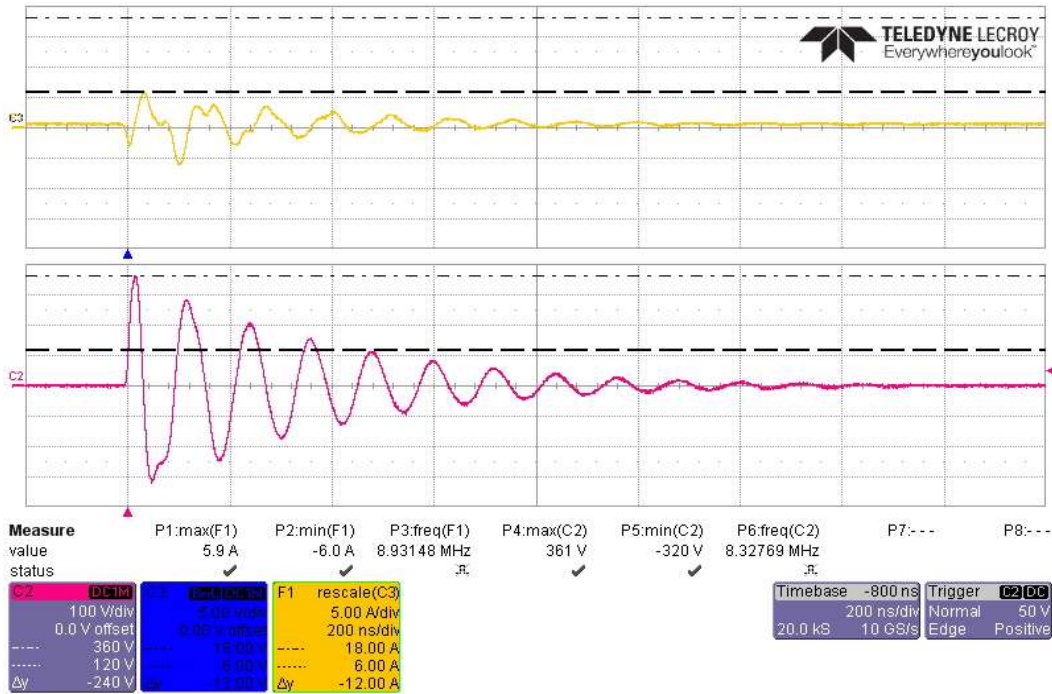

Actual Test CS117 Waveform #3 at 10MHz, First Transient +360V/6A, on Power Line 1

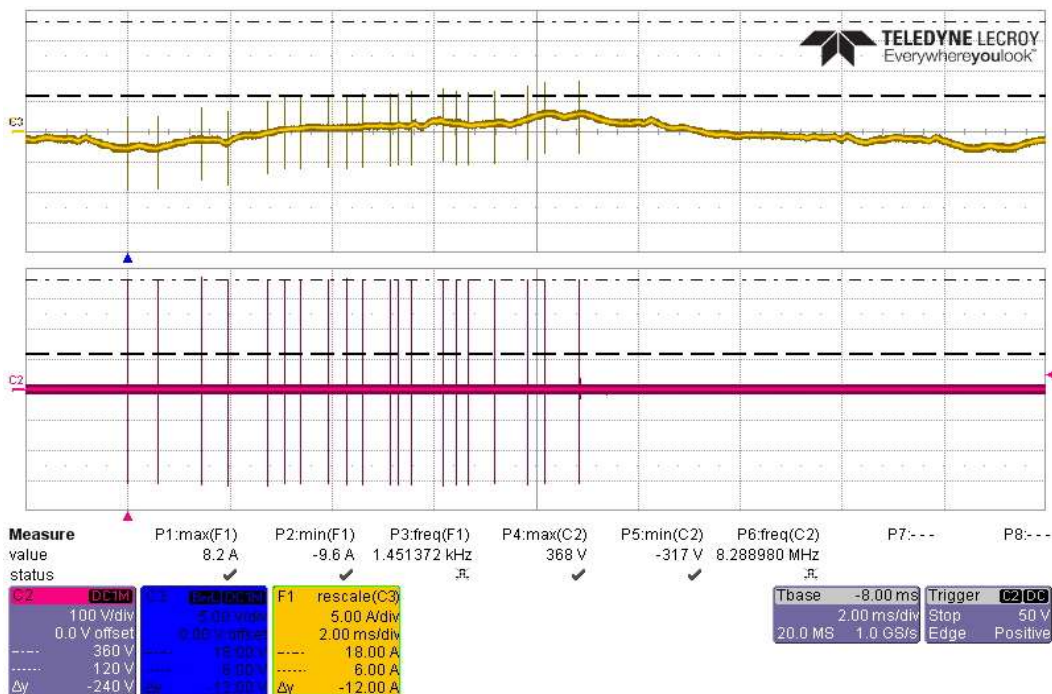

Actual Test CS117 Waveform #3 at 10MHz, 20 Transients +360V/6A, on Power Line 1

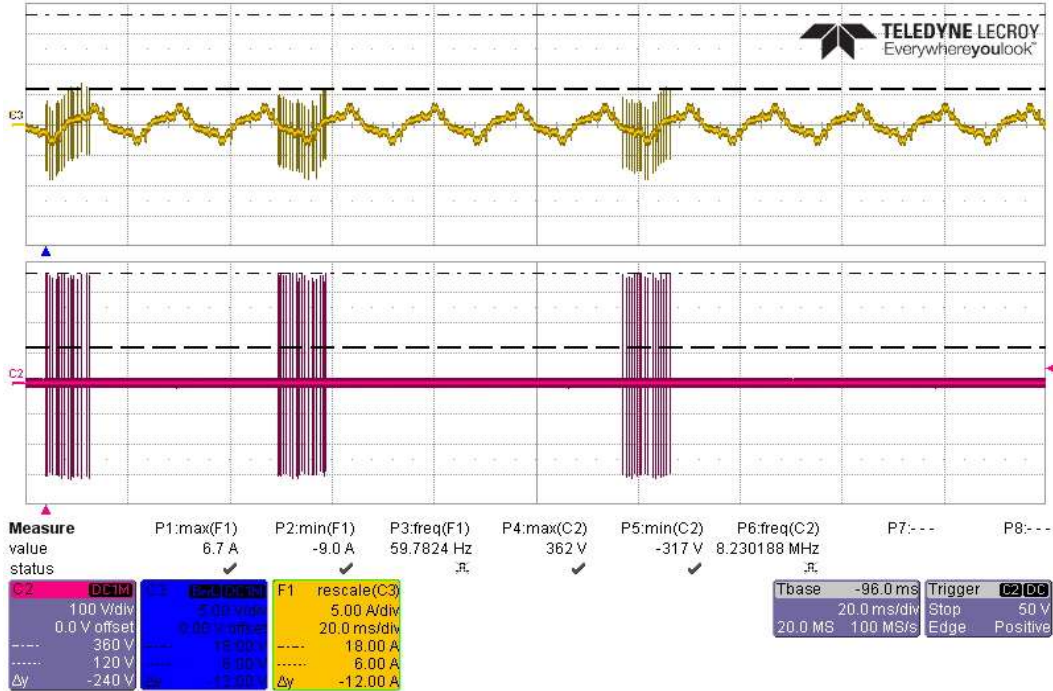

Actual Test CS117 Waveform #3 at 10MHz, 3 Bursts +360V/6A, on Power Line 1

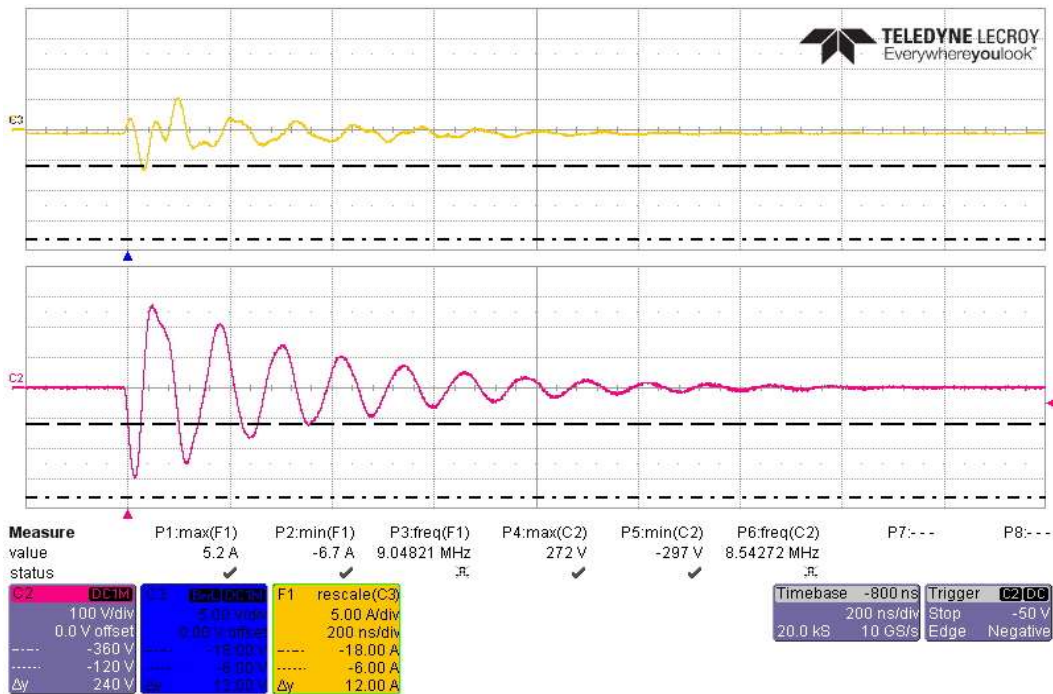

Actual Test CS117 Waveform #3 at 10MHz, First Transient -360V/6A, on Power Line 1

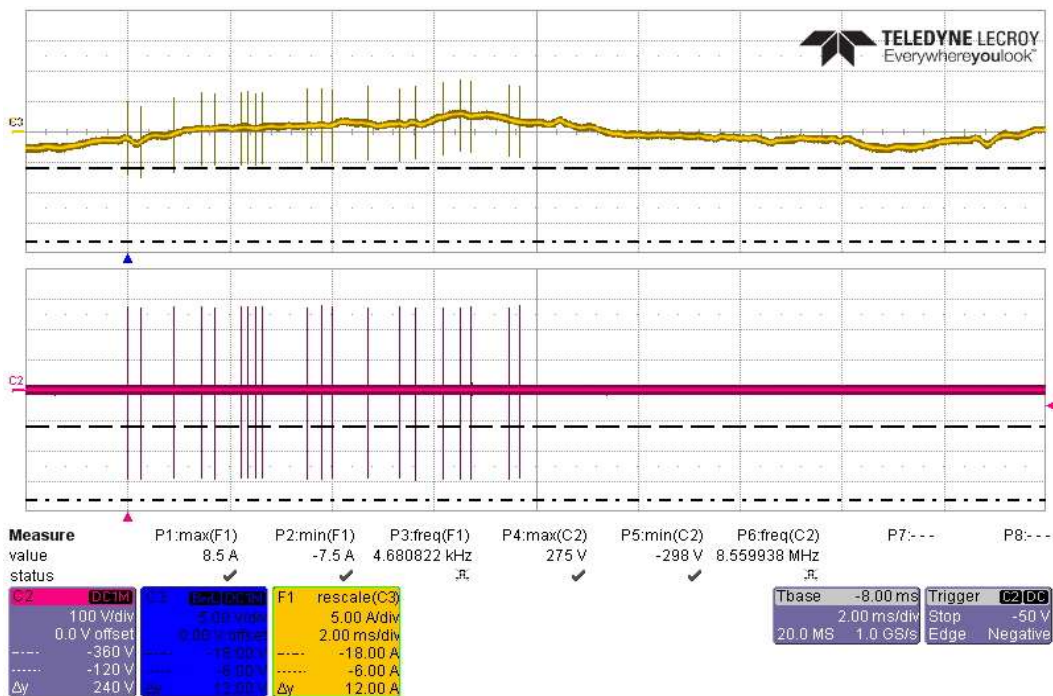

Actual Test CS117 Waveform #3 at 10MHz, 20 Transients -360V/6A, on Power Line 1

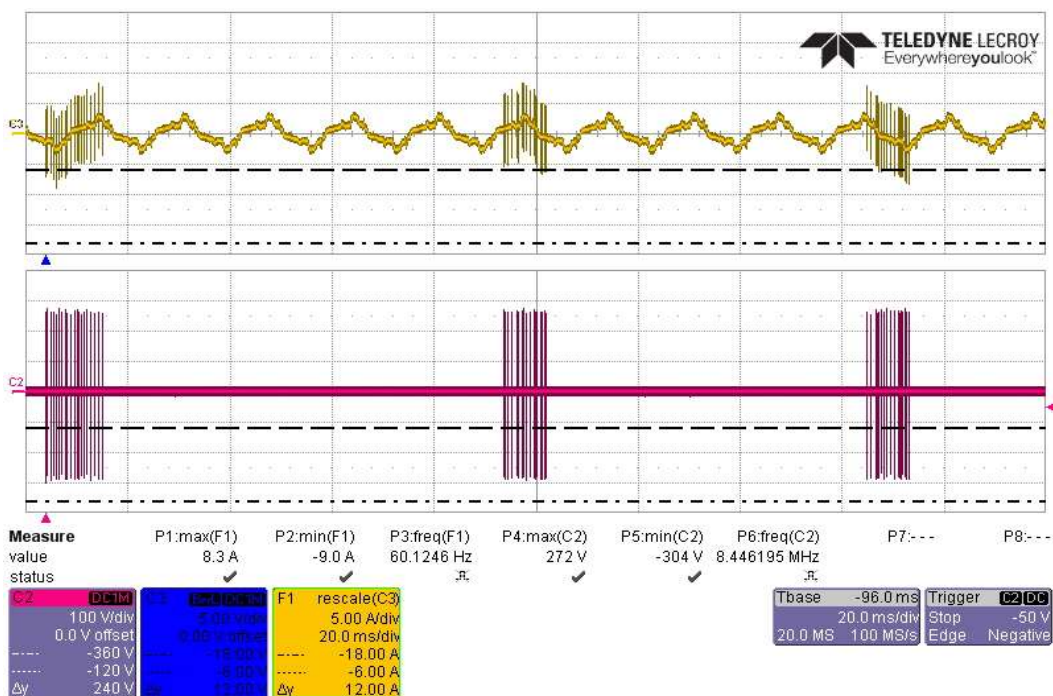

Actual Test CS117 Waveform #3 at 10MHz, 3 Bursts -360V/6A, on Power Line 1

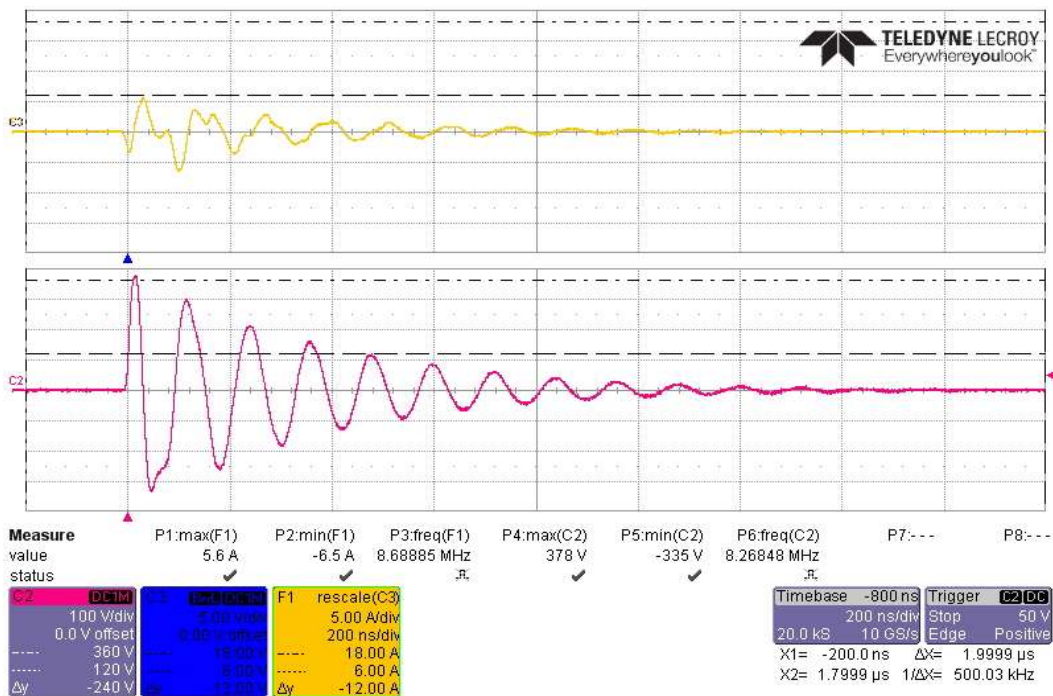

Actual Test CS117 Waveform #3 at 10MHz, First Transient +360V/6A, on Power Line 2

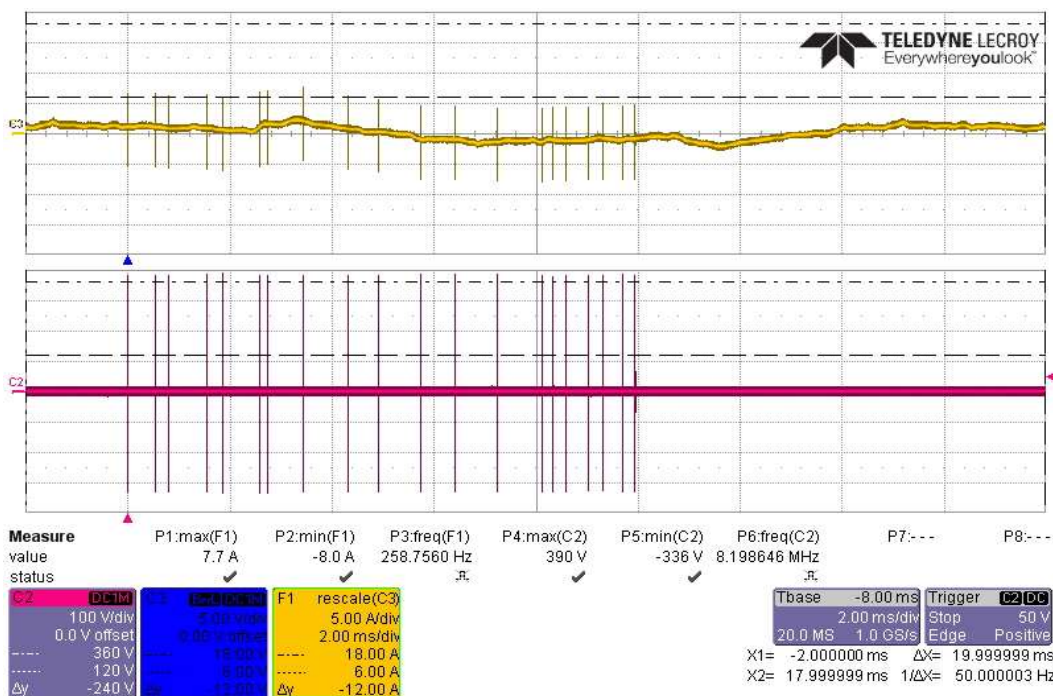

Actual Test CS117 Waveform #3 at 10MHz, 20 Transients +360V/6A, on Power Line 2

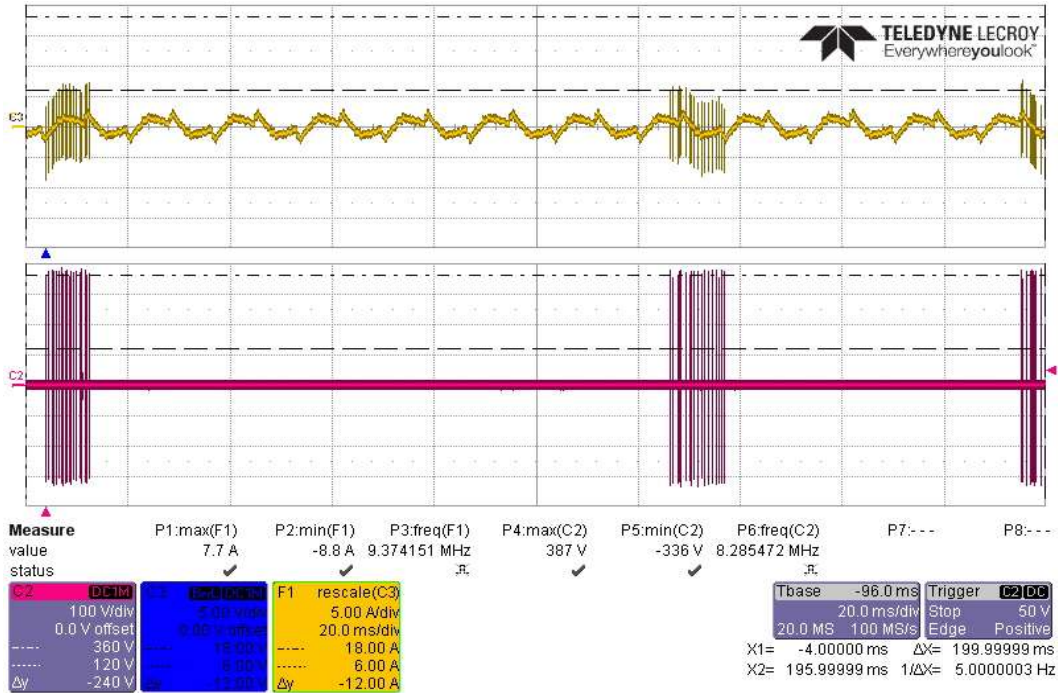

Actual Test CS117 Waveform #3 at 10MHz, 3 Bursts +360V/6A, on Power Line 2

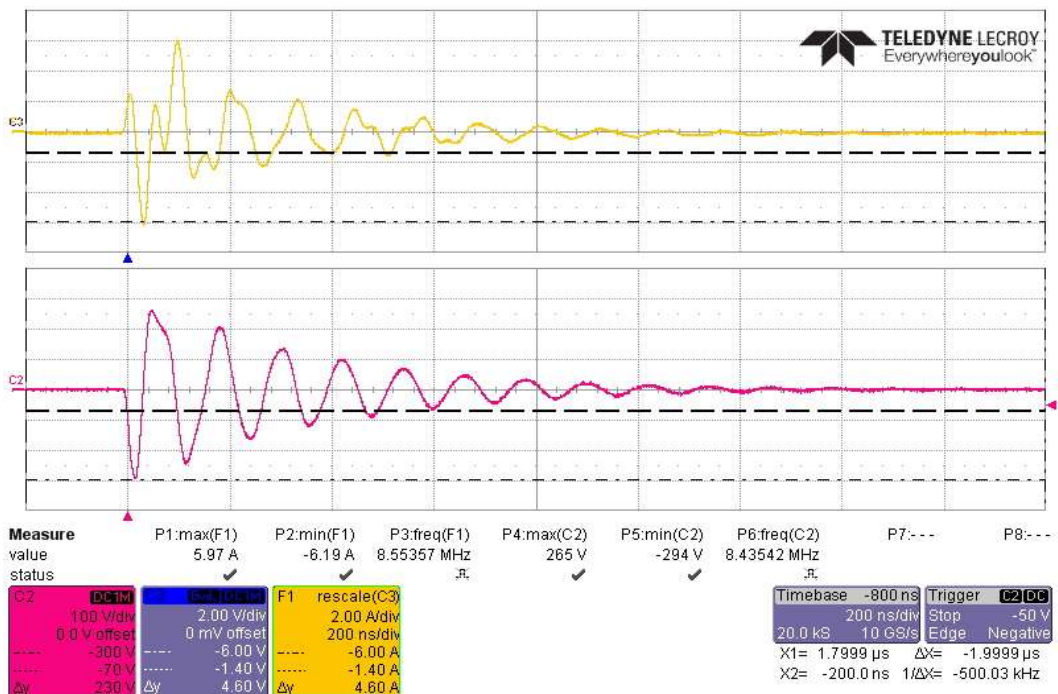

Actual Test CS117 Waveform #3 at 10MHz, First Transient -360V/6A, on Power Line 2

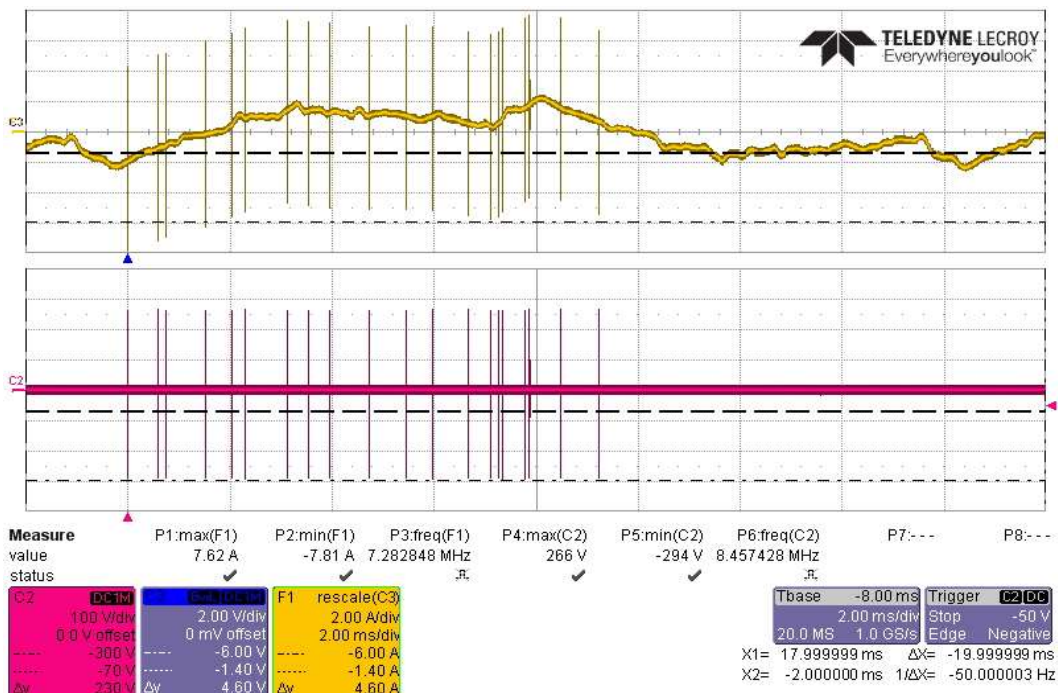

Actual Test CS117 Waveform #3 at 10MHz, 20 Transients -360V/6A, on Power Line 2

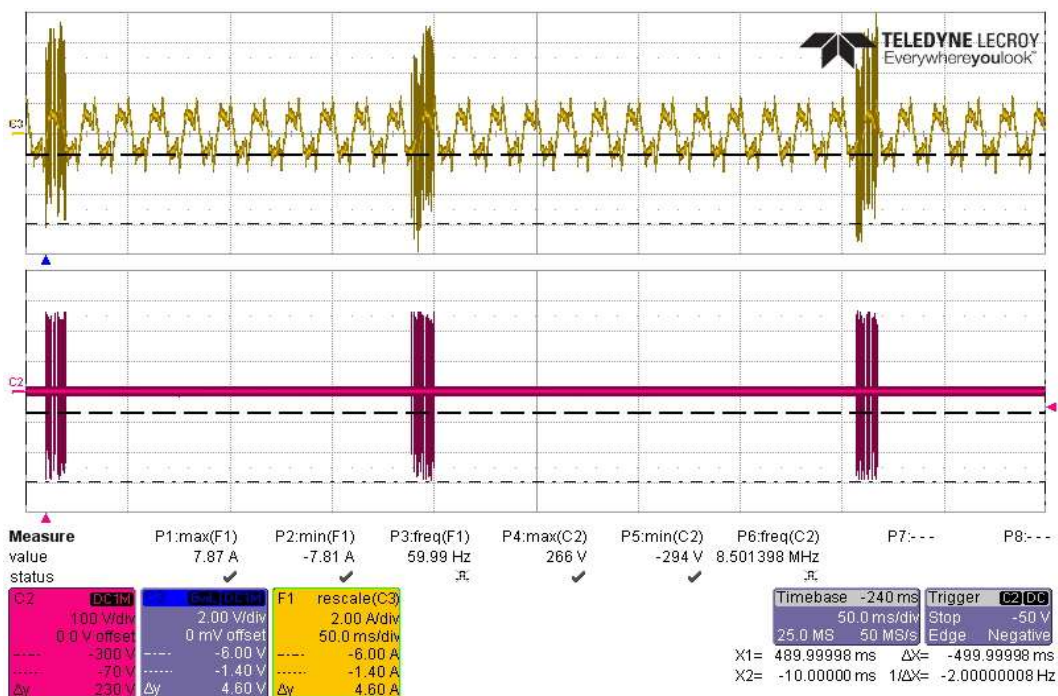

Actual Test CS117 Waveform #3 at 10MHz, 3 Bursts -360V/6A, on Power Line 2

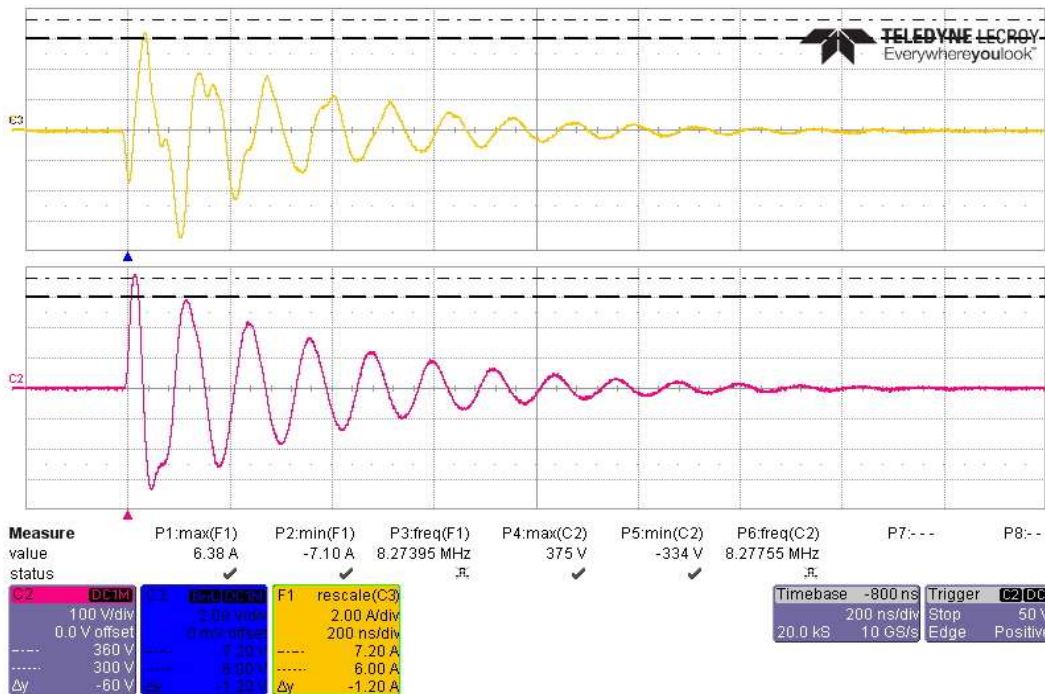

Actual Test CS117 Waveform #3 at 10MHz, First Transient +360V/6A, on Power Lines

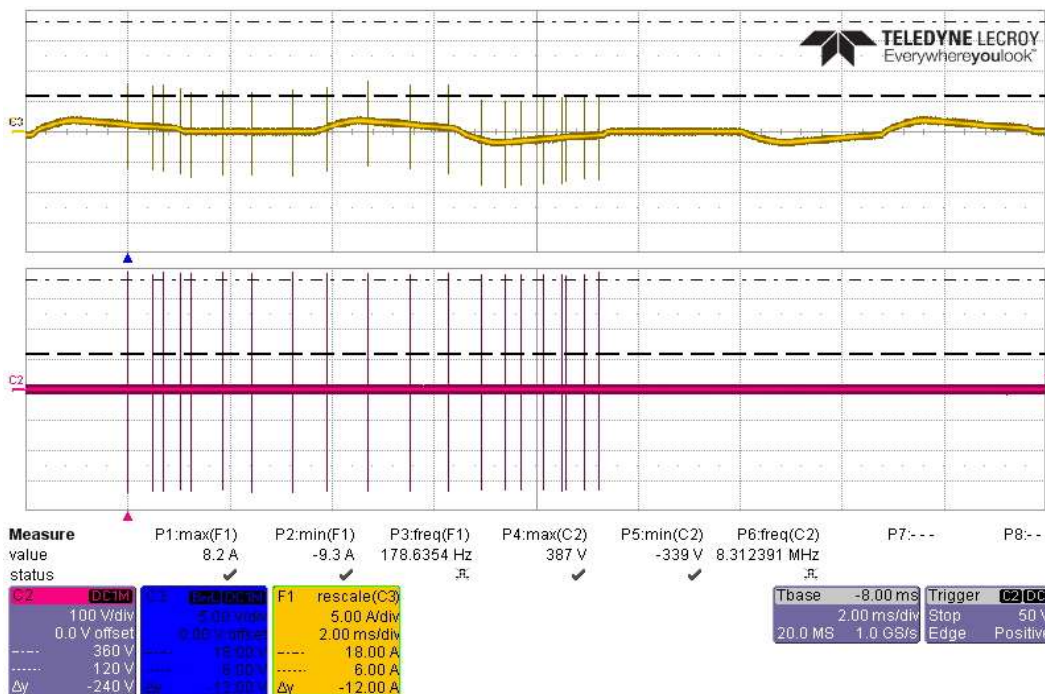

Actual Test CS117 Waveform #3 at 10MHz, 20 Transients +360V/6A, on Power Lines

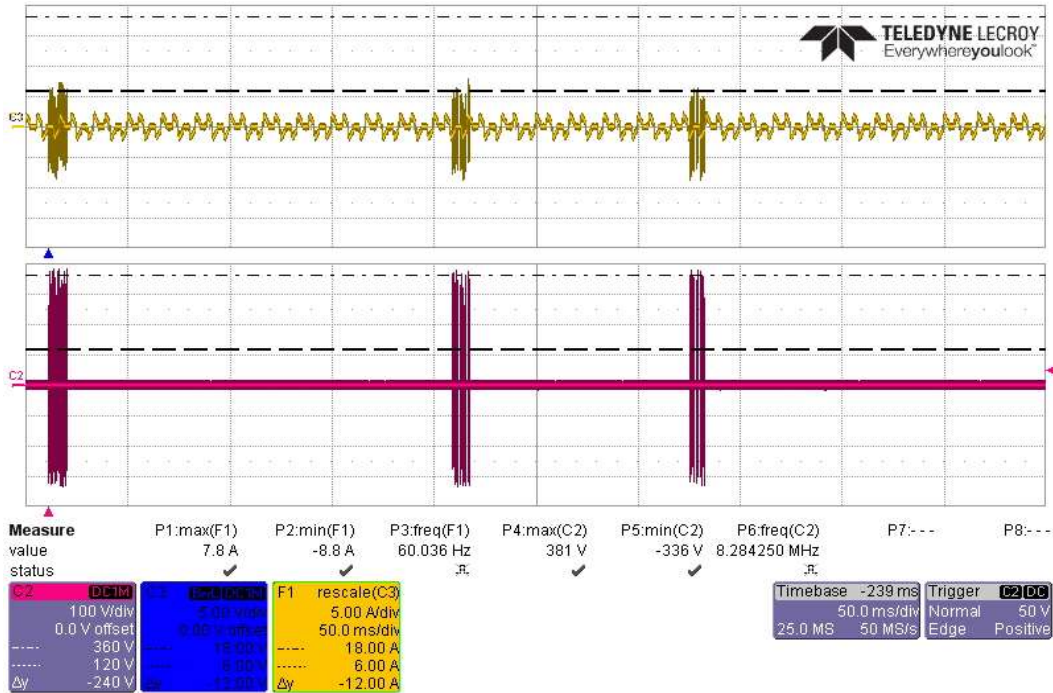

Actual Test CS117 Waveform #3 at 10MHz, 3 Bursts +360V/6A, on Power Lines

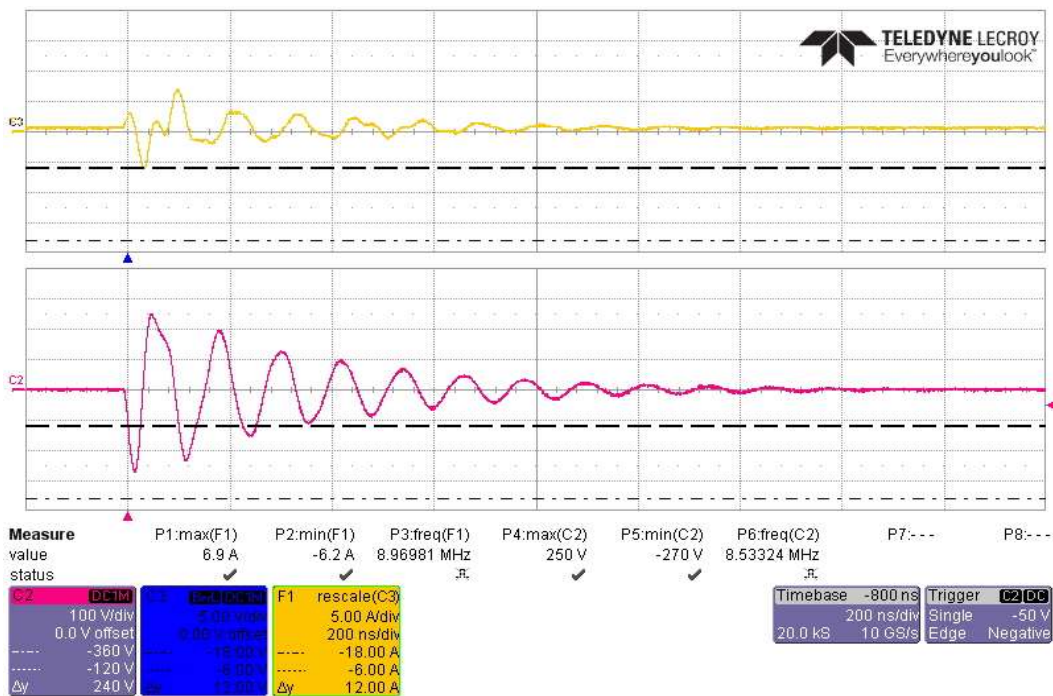

Actual Test CS117 Waveform #3 at 10MHz, First Transient -360V/6A, on Power Lines

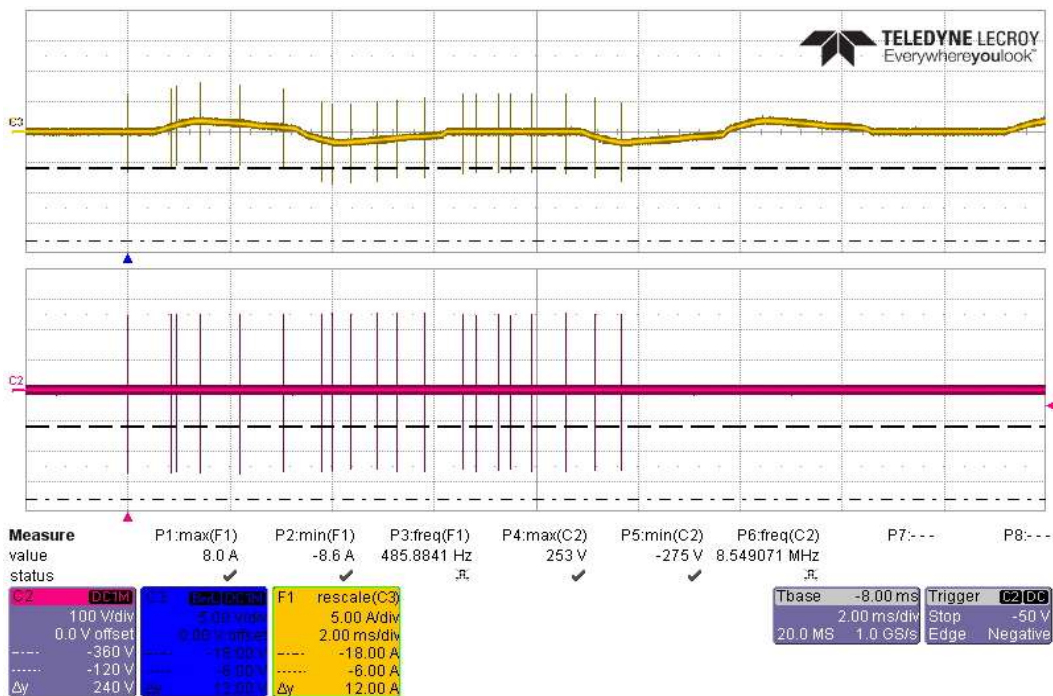

Actual Test CS117 Waveform #3 at 10MHz, 20 Transients -360V/6A, on Power Lines

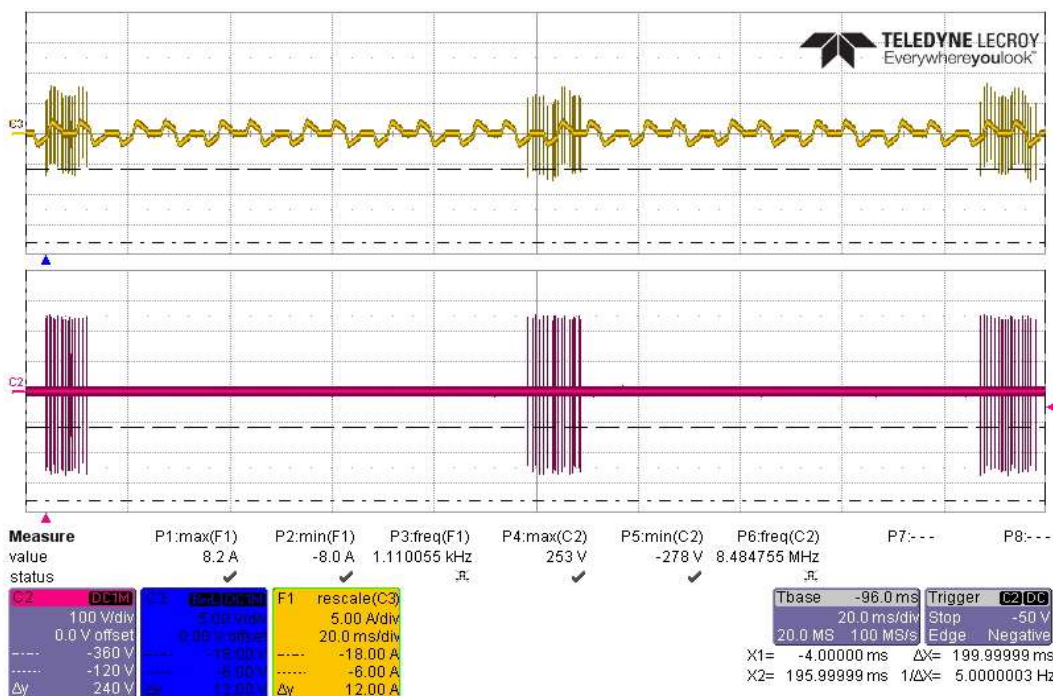

Actual Test CS117 Waveform #3 at 10MHz, 3 Bursts -360V/6A, on Power Lines

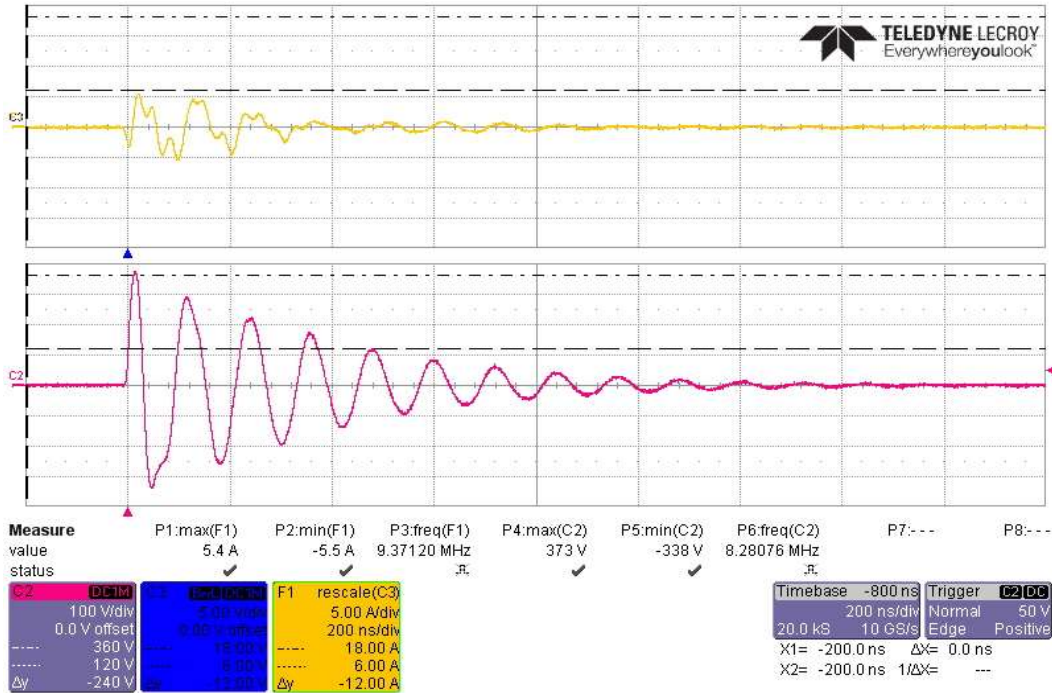

Actual Test CS117 Waveform #3 at 10MHz, First Transient +360V/6A, on Battery High Side

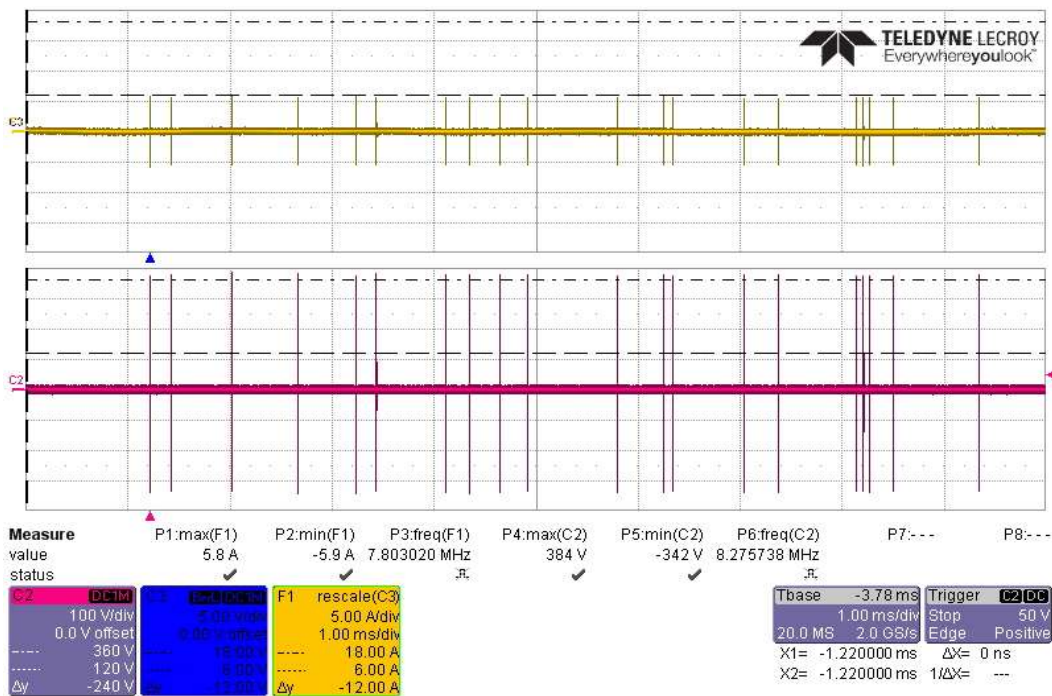

Actual Test CS117 Waveform #3 at 10MHz, 20 Transients +360V/6A, on Battery High Side

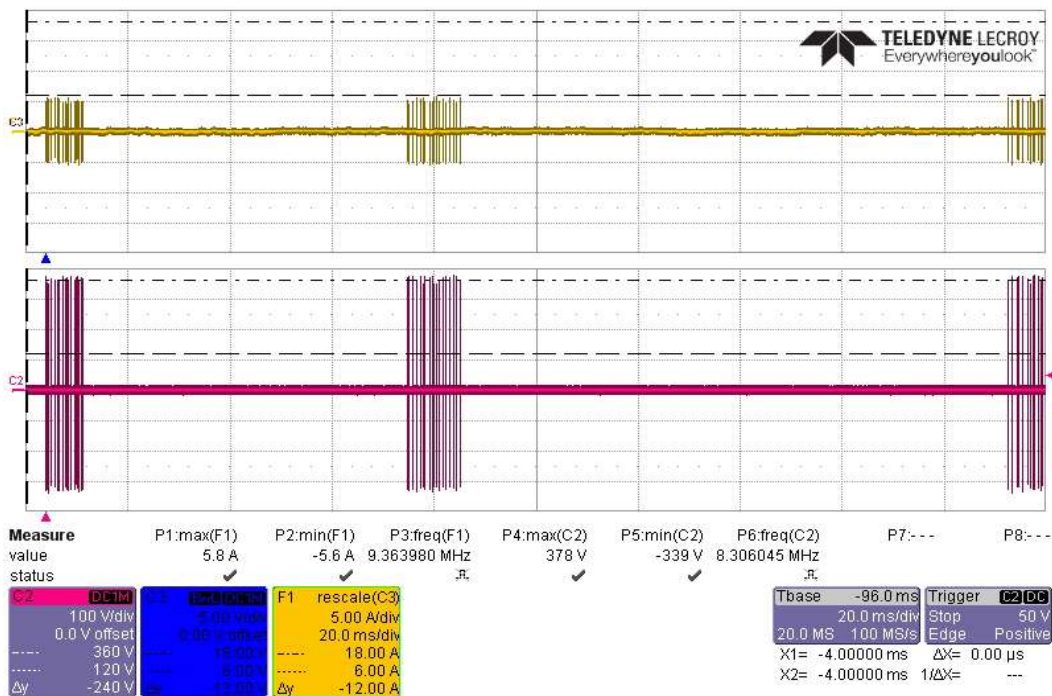

Actual Test CS117 Waveform #3 at 10MHz, 3 Bursts +360V/6A, on Battery High Side

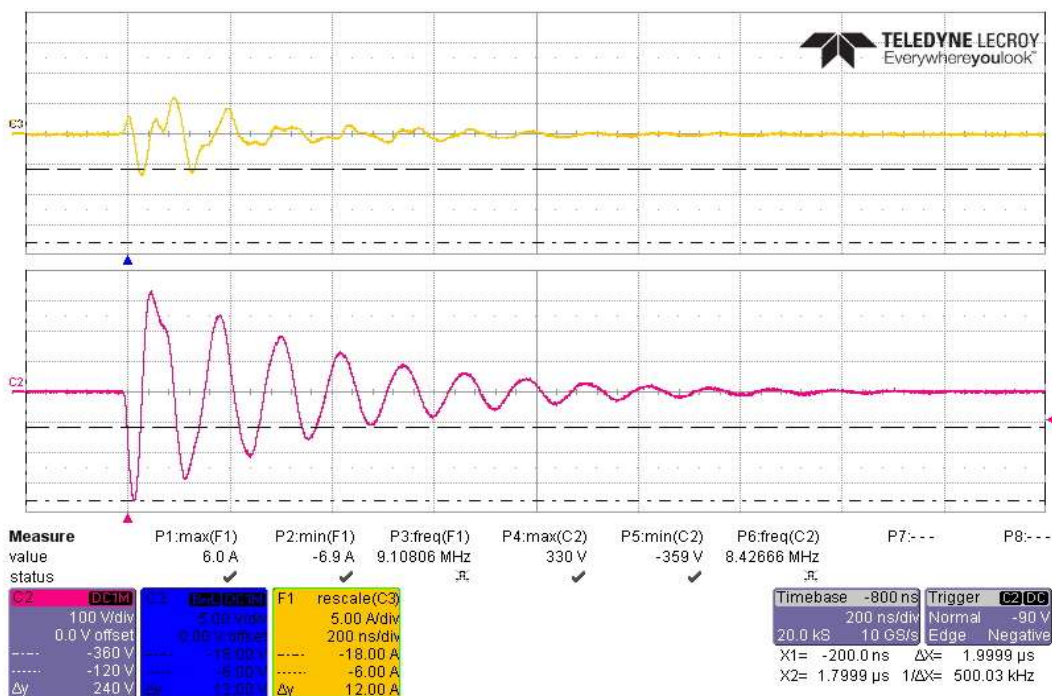

Actual Test CS117 Waveform #3 at 10MHz, First Transient -360V/6A, on Battery High Side

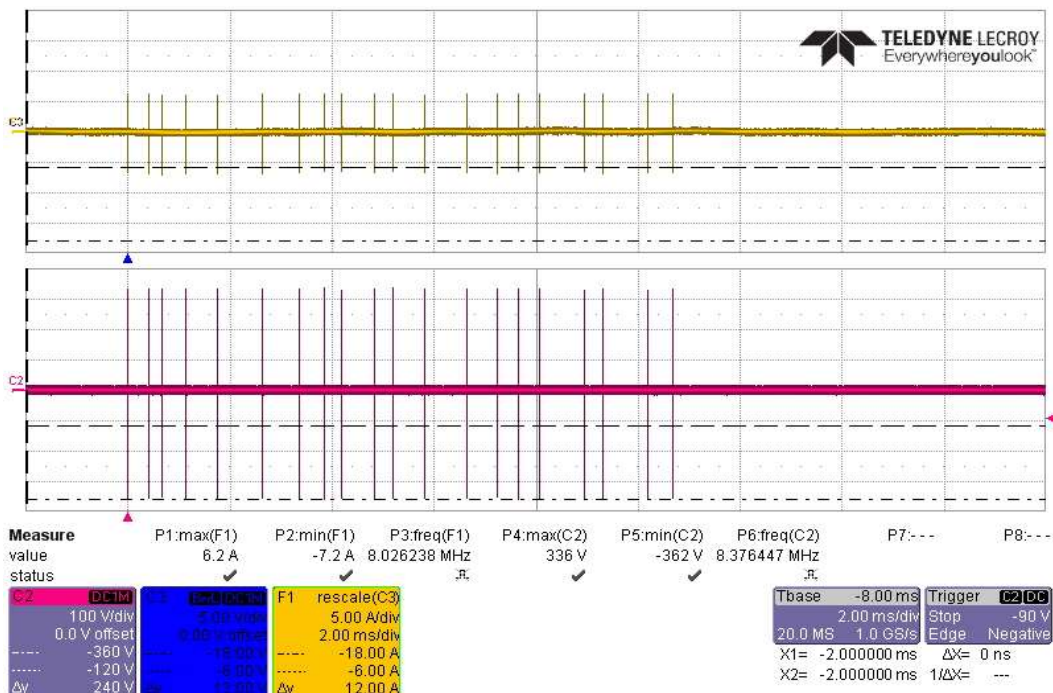

Actual Test CS117 Waveform #3 at 10MHz, 20 Transients -360V/6A, on Battery High Side

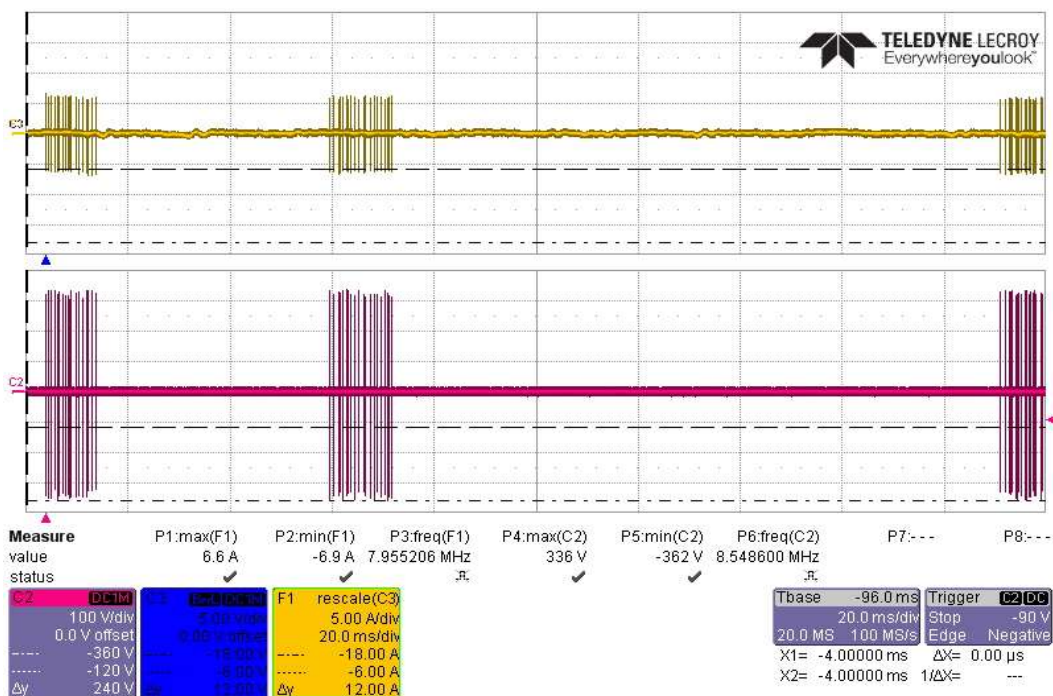

Actual Test CS117 Waveform #3 at 10MHz, 3 Bursts -360V/6A, on Battery High Side

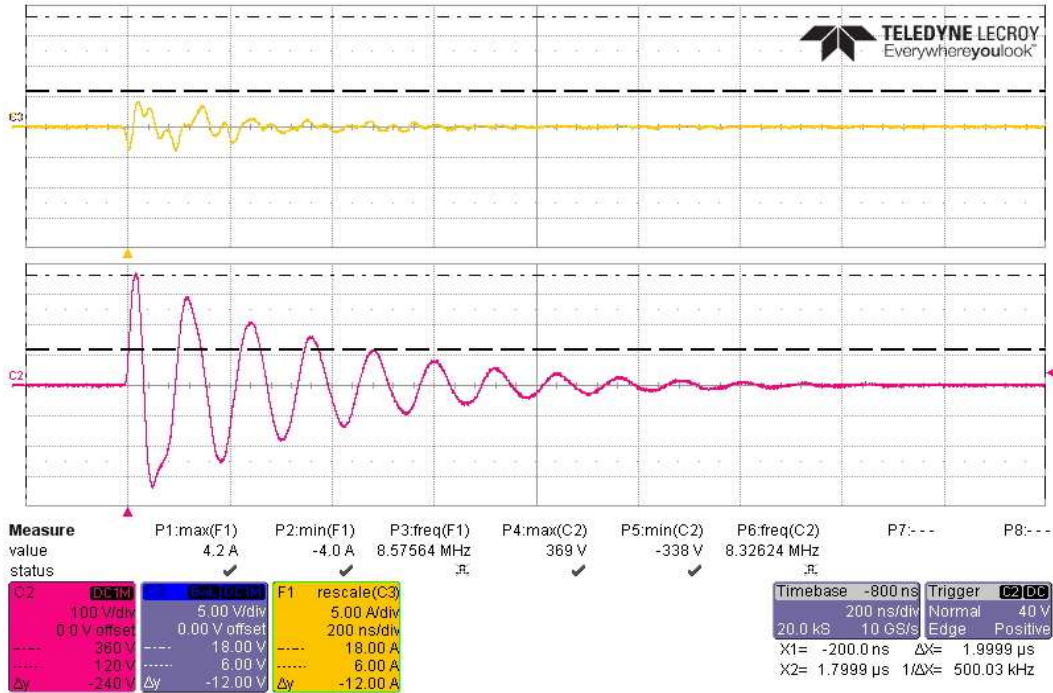

Actual Test CS117 Waveform #3 at 10MHz, First Transient +360V/6A, on Battery Return Side

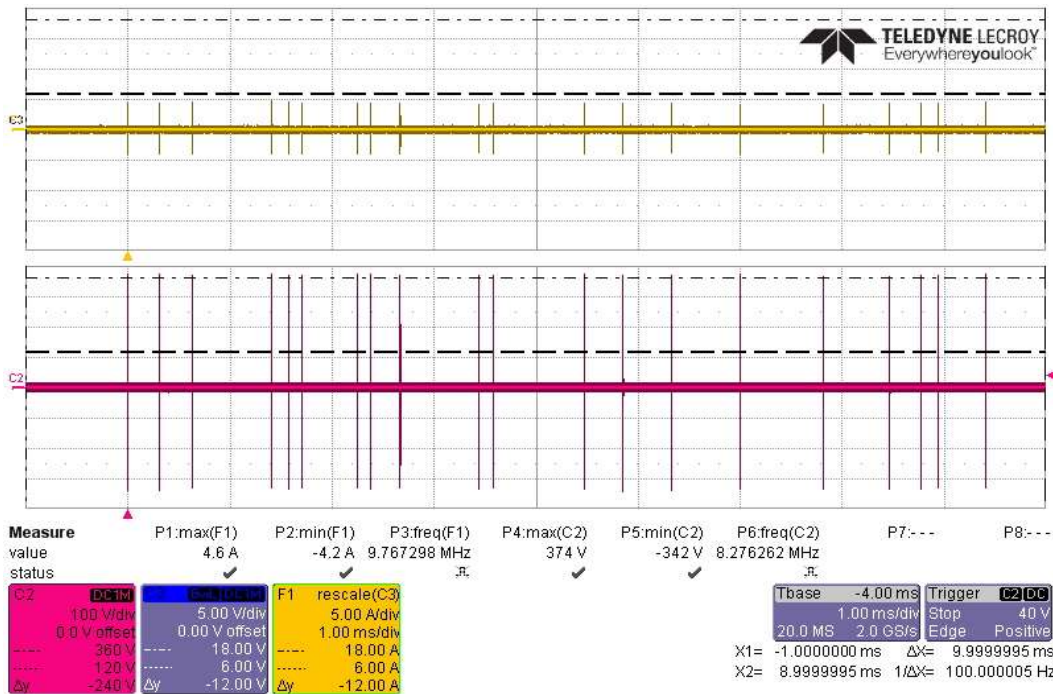

Actual Test CS117 Waveform #3 at 10MHz, 20 Transients +360V/6A, on Battery Return Side

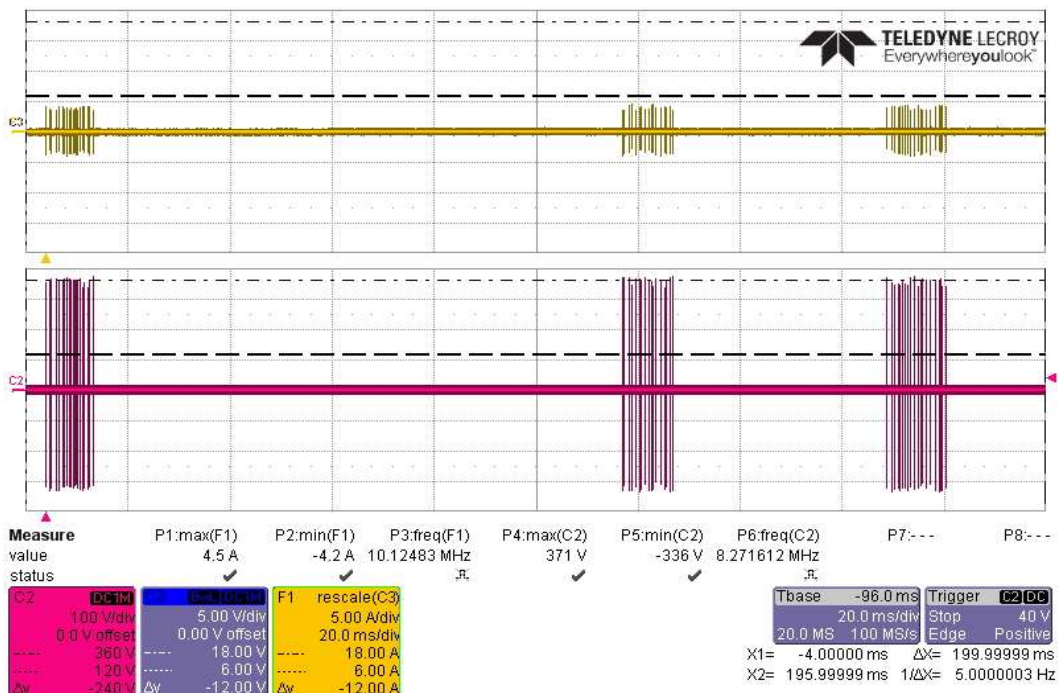

Actual Test CS117 Waveform #3 at 10MHz, 3 Bursts +360V/6A, on Battery Return Side

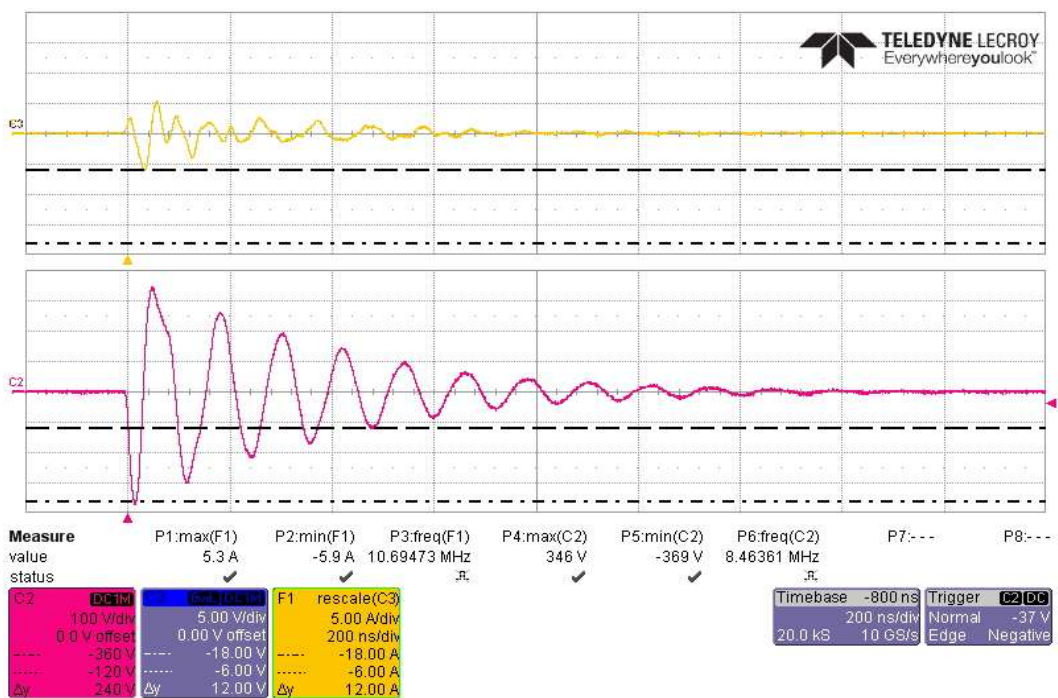

Actual Test CS117 Waveform #3 at 10MHz, First Transient -360V/6A, on Battery Return Side

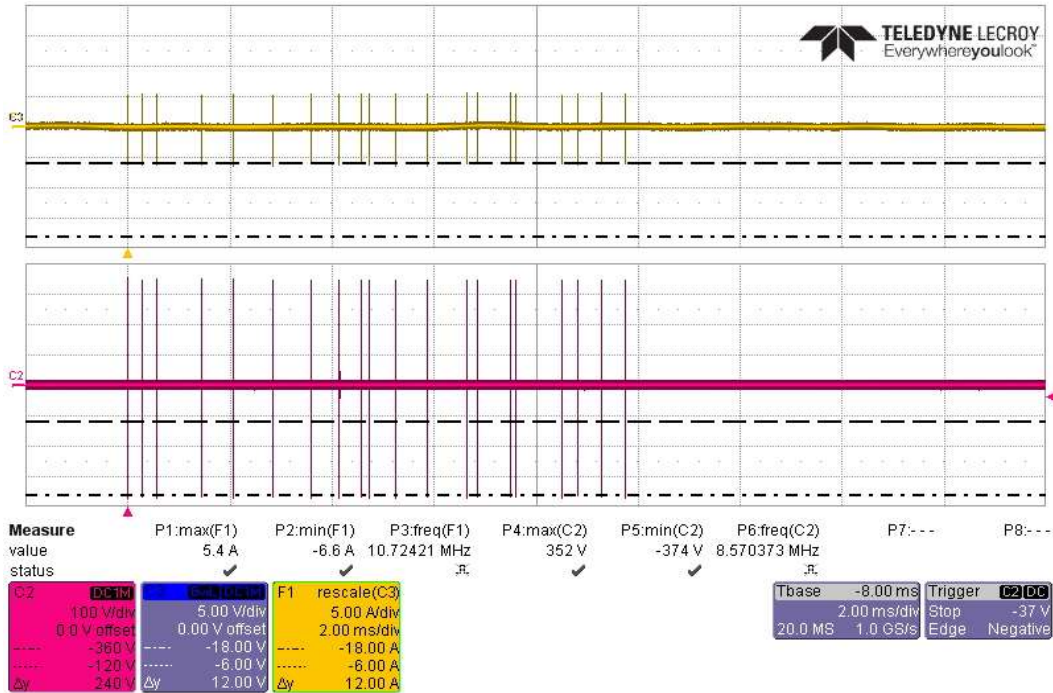

Actual Test CS117 Waveform #3 at 10MHz, 20 Transients -360V/6A, on Battery Return Side

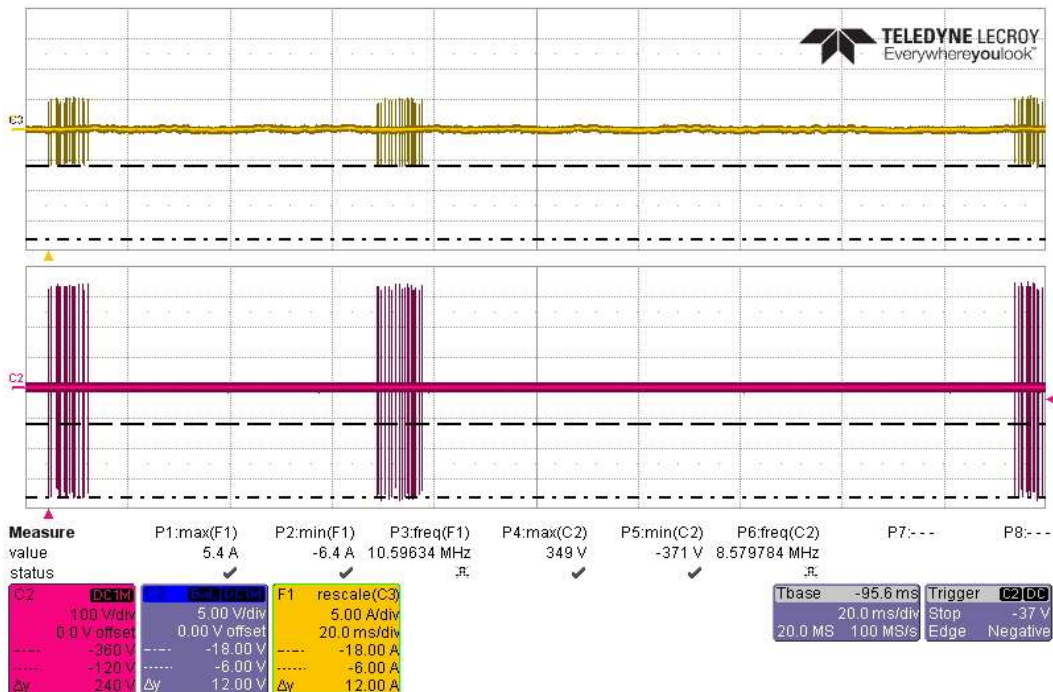

Actual Test CS117 Waveform #3 at 10MHz, 3 Bursts -360V/6A, on Battery Return Side

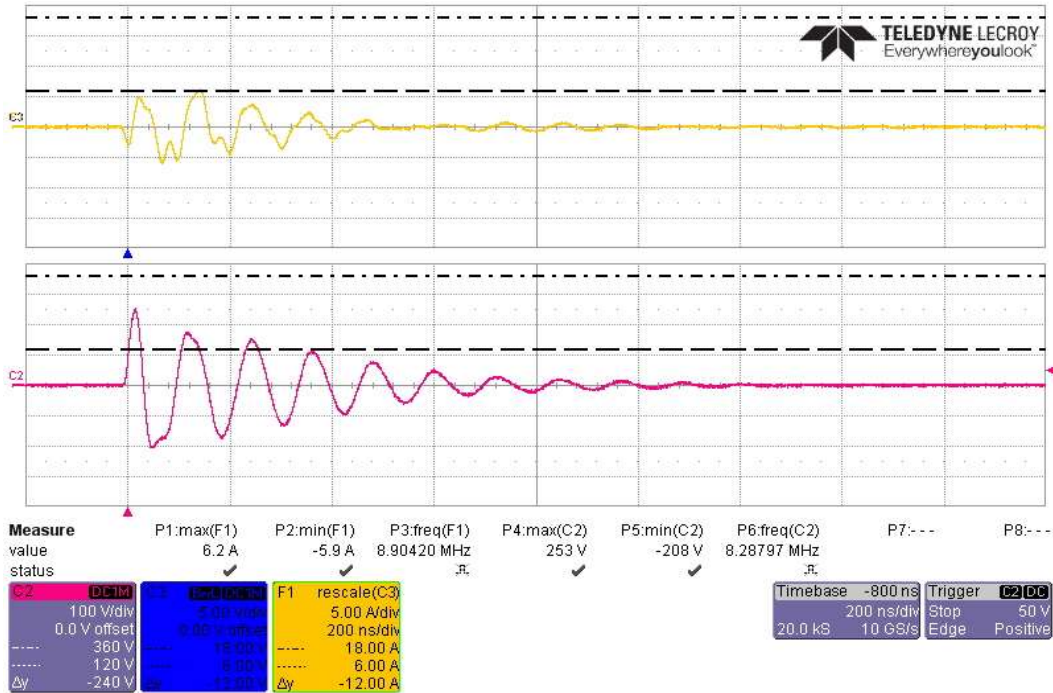

Actual Test CS117 Waveform #3 at 10MHz, First Transient +360V/6A, on Battery Bundle

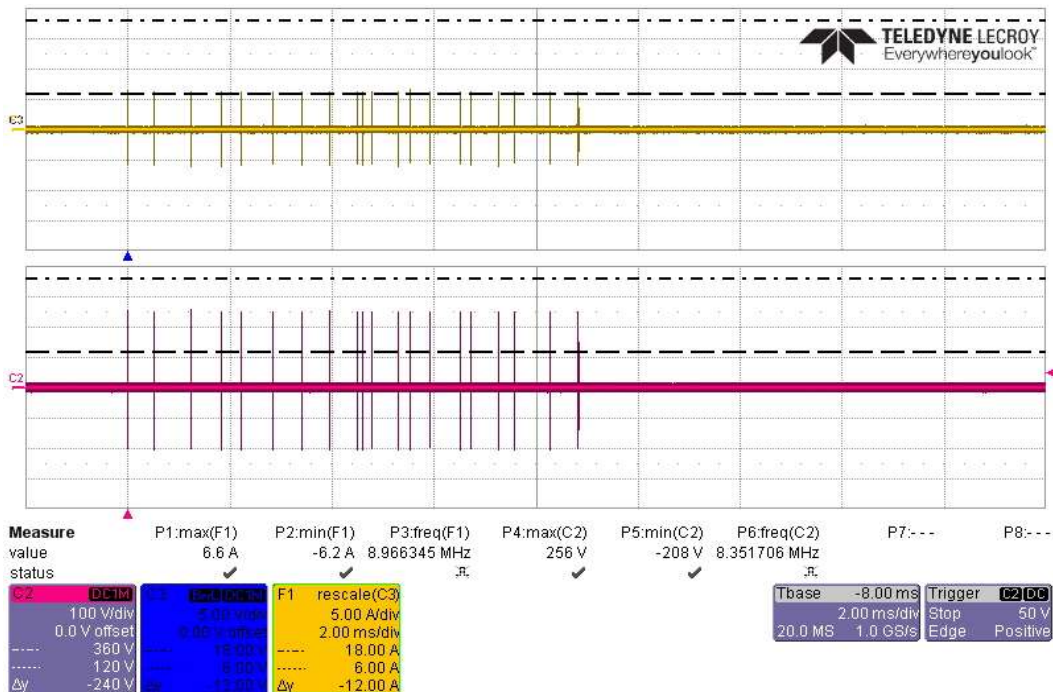

Actual Test CS117 Waveform #3 at 10MHz, 20 Transients +360V/6A, on Battery Bundle

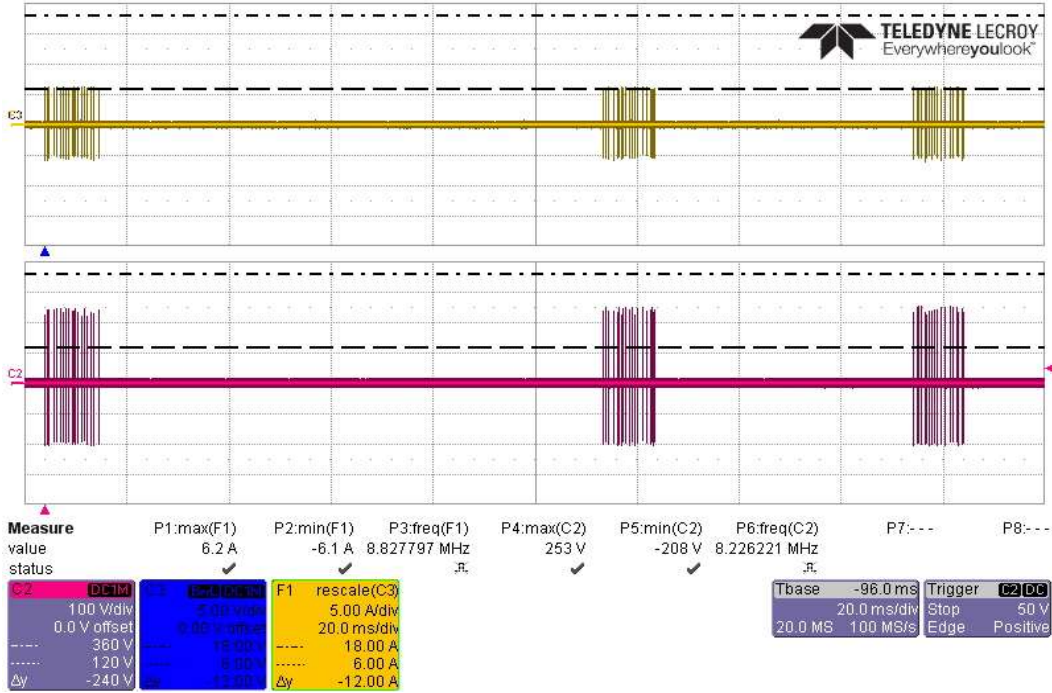

Actual Test CS117 Waveform #3 at 10MHz, 3 Bursts +360V/6A, on Battery Bundle

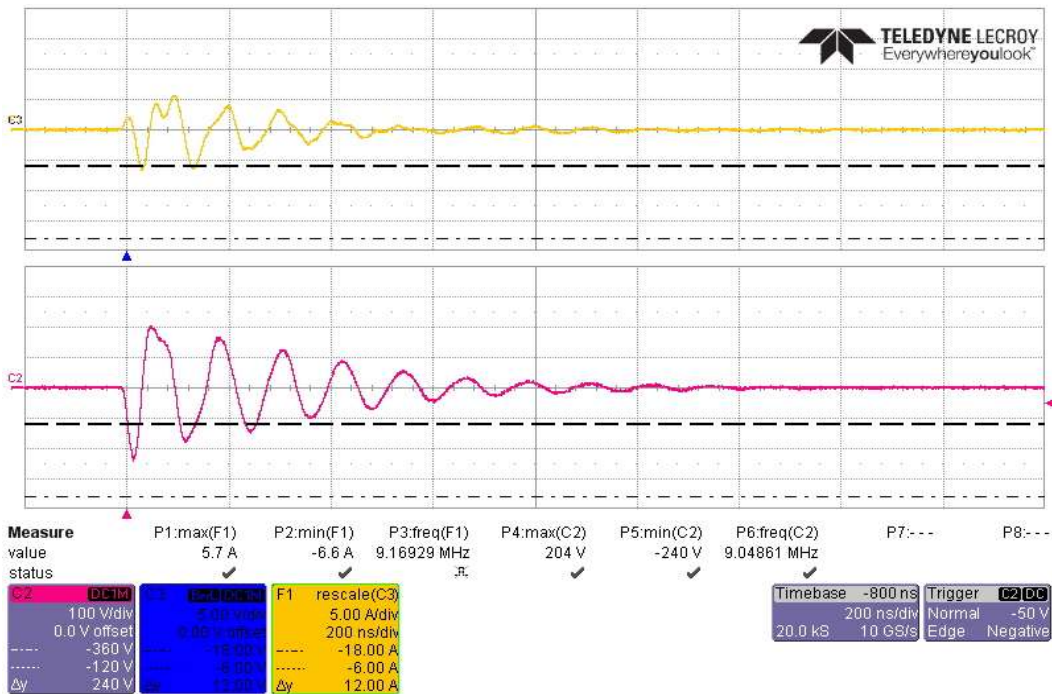

Actual Test CS117 Waveform #3 at 10MHz, First Transient -360V/6A, on Battery Bundle

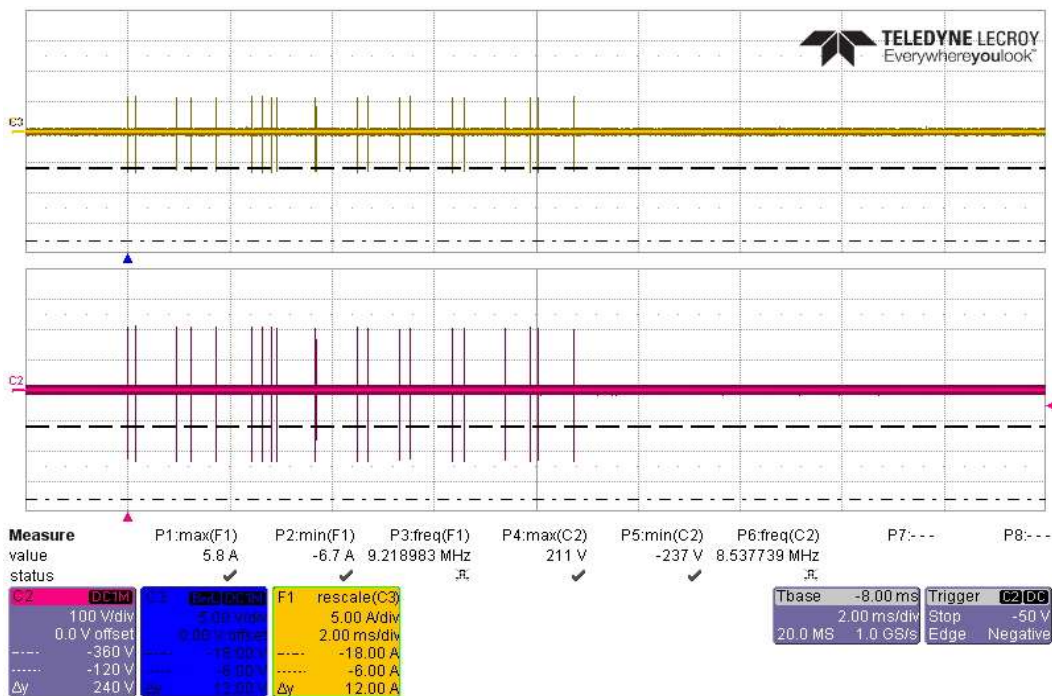

Actual Test CS117 Waveform #3 at 10MHz, 20 Transients -360V/6A, on Battery Bundle

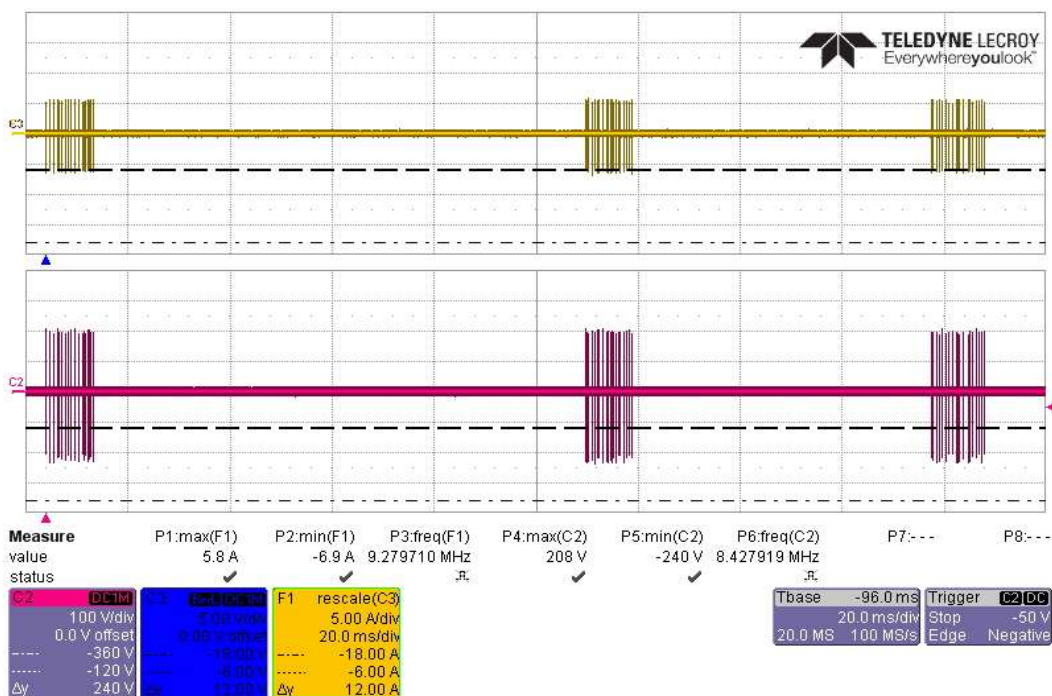

Actual Test CS117 Waveform #3 at 10MHz, 3 Bursts -360V/6A, on Battery Bundle

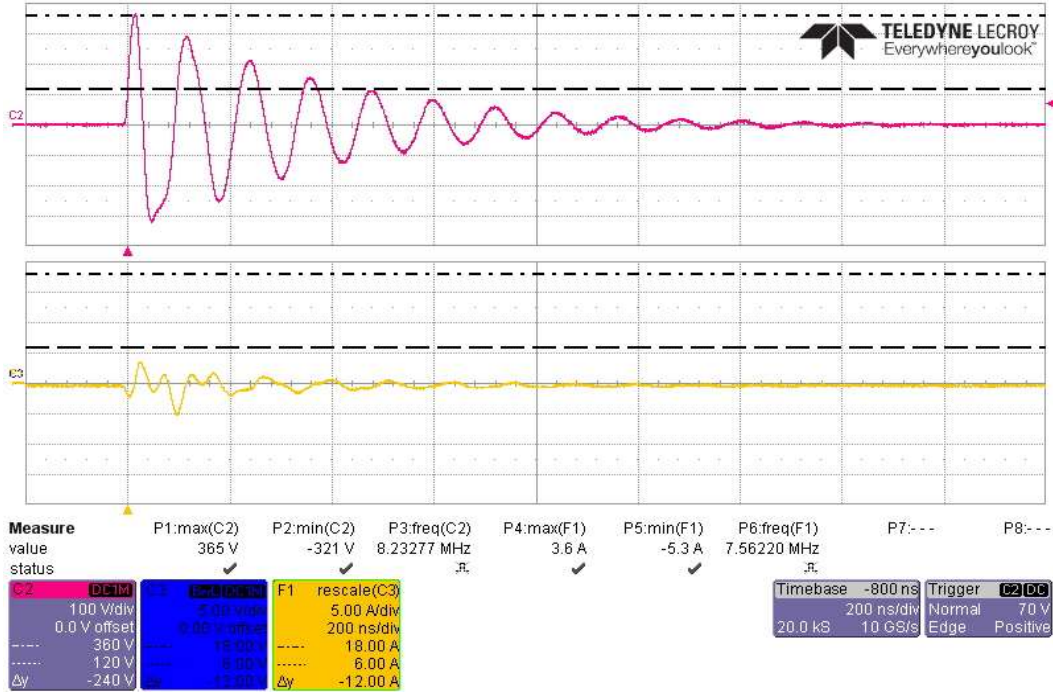

Actual Test CS117 Waveform #3 at 10MHz, First Transient +360V/6A, on PV High Side

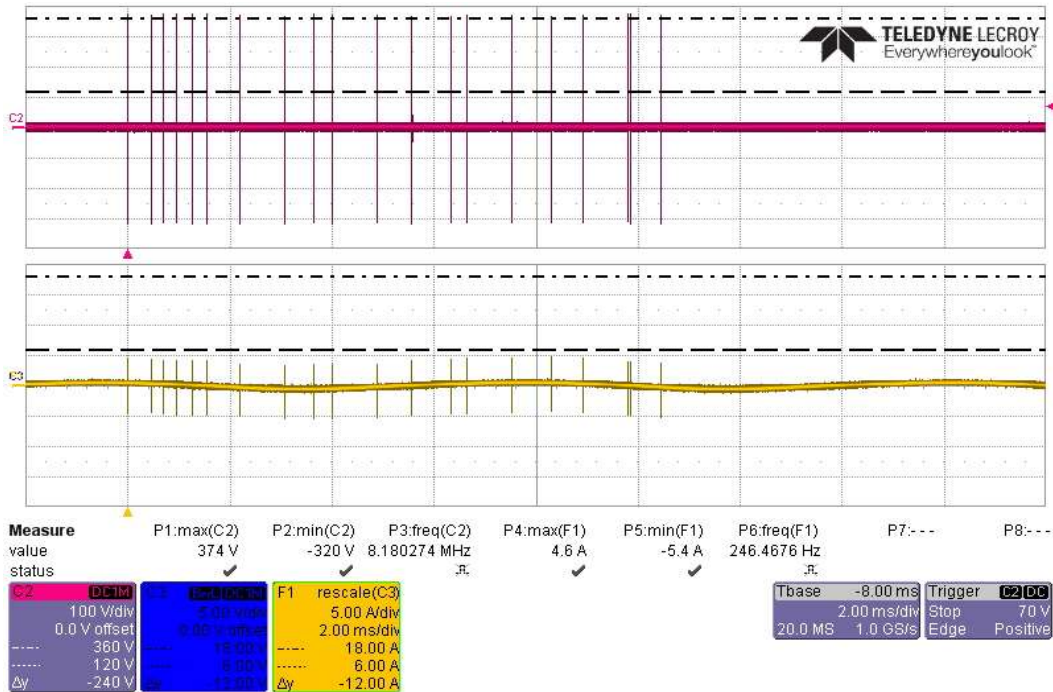

Actual Test CS117 Waveform #3 at 10MHz, 20 Transients +360V/6A, on PV High Side

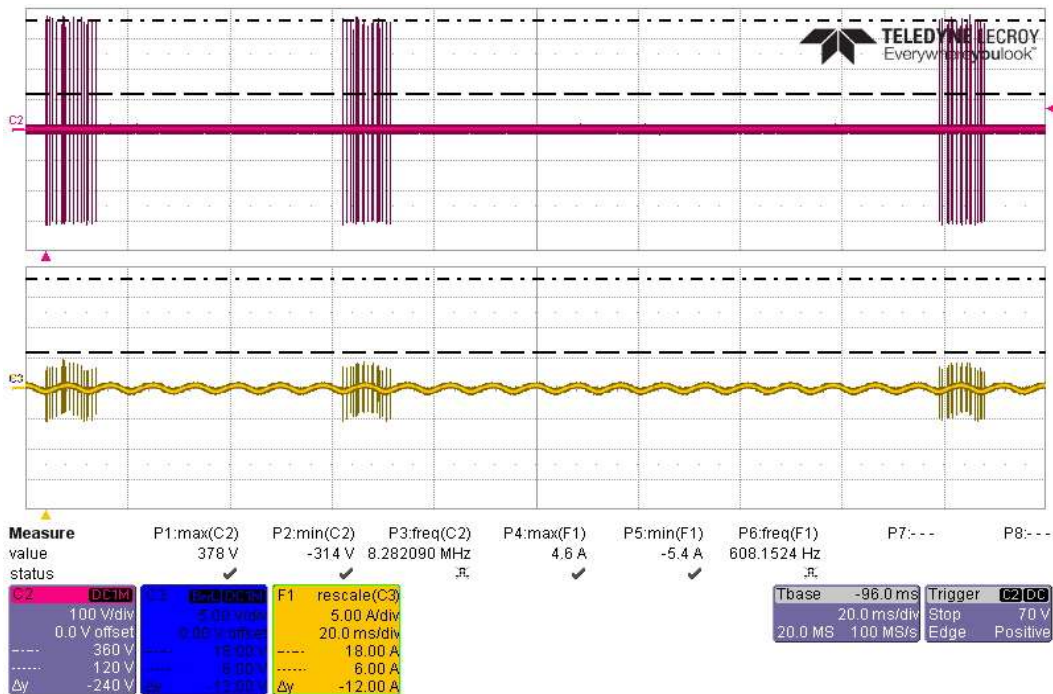

Actual Test CS117 Waveform #3 at 10MHz, 3 Bursts +360V/6A, on PV High Side

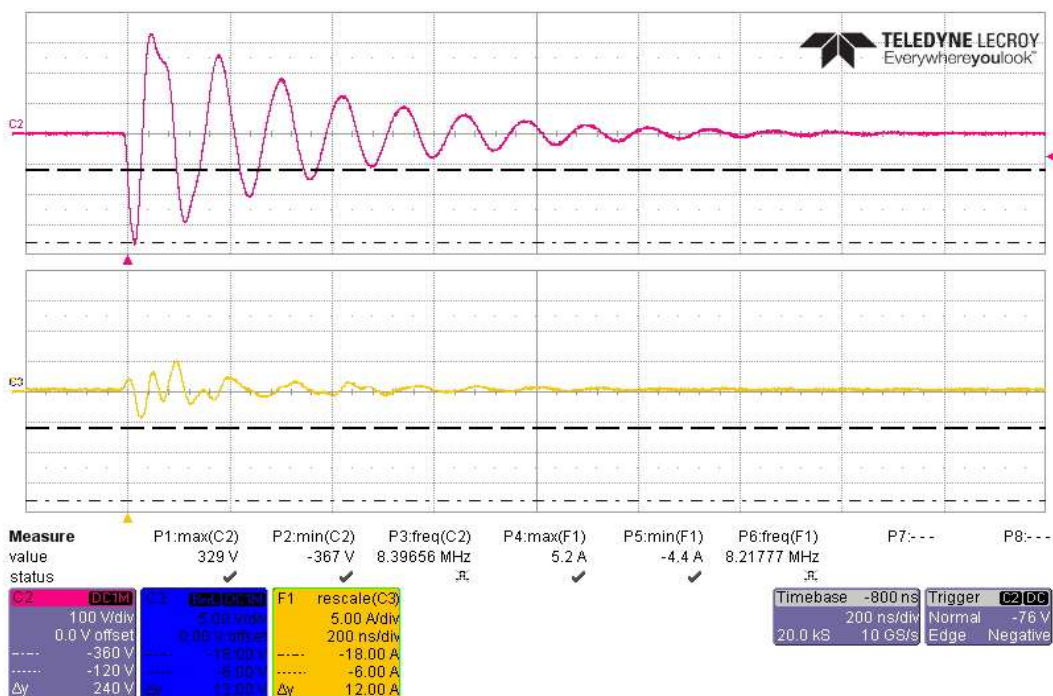

Actual Test CS117 Waveform #3 at 10MHz, First Transient -360V/6A, on PV High Side

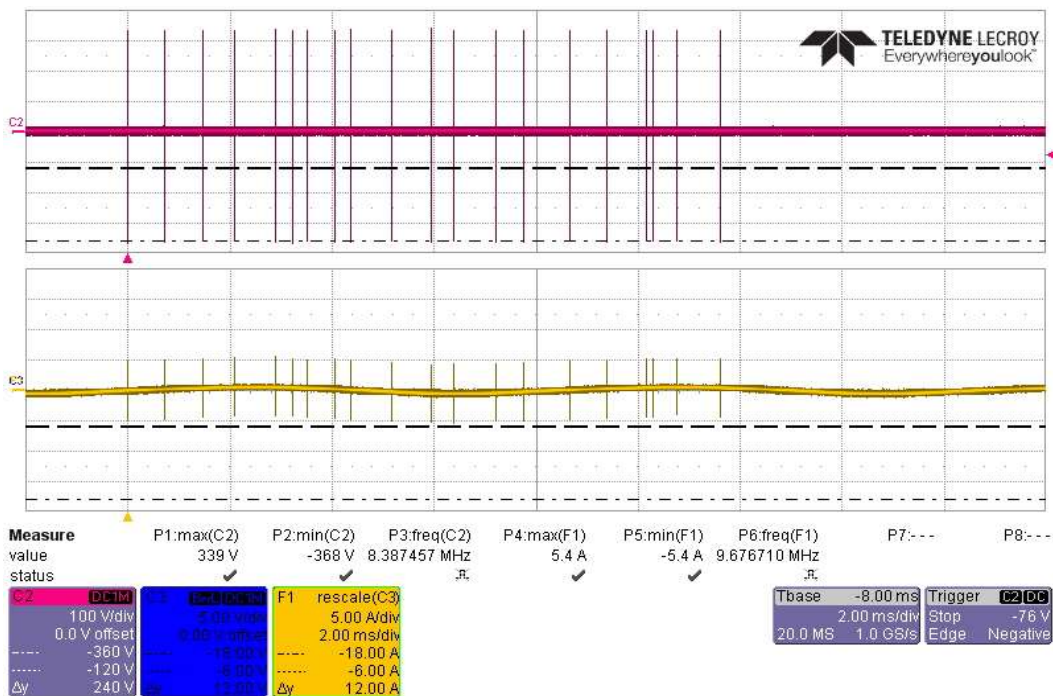

Actual Test CS117 Waveform #3 at 10MHz, 20 Transients -360V/6A, on PV High Side

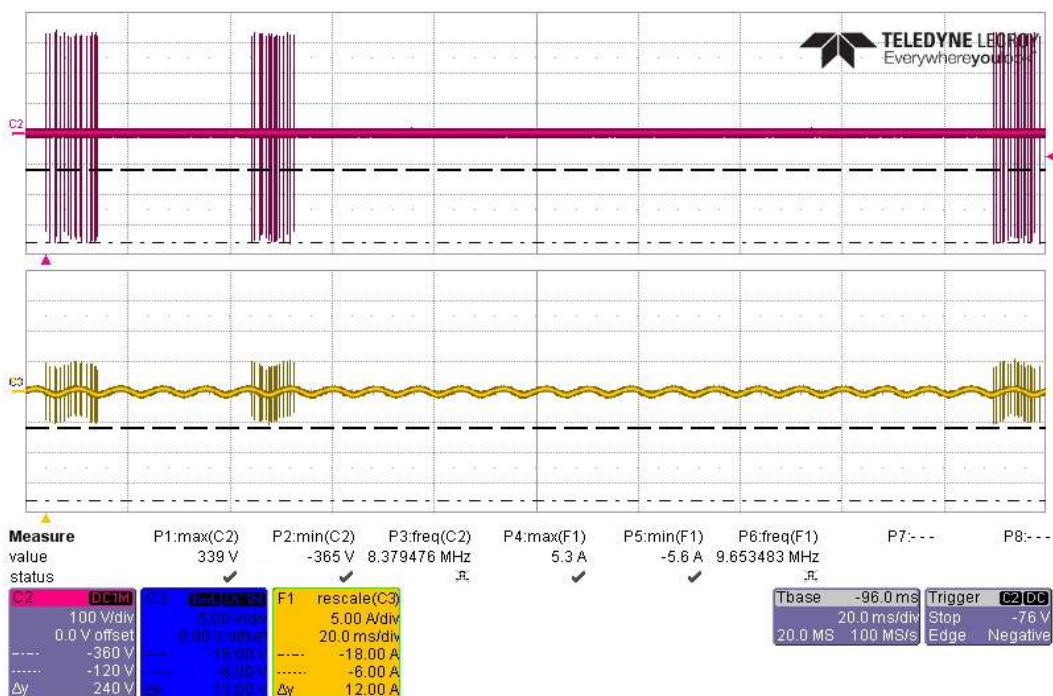

Actual Test CS117 Waveform #3 at 10MHz, 3 Bursts -360V/6A, on PV High Side

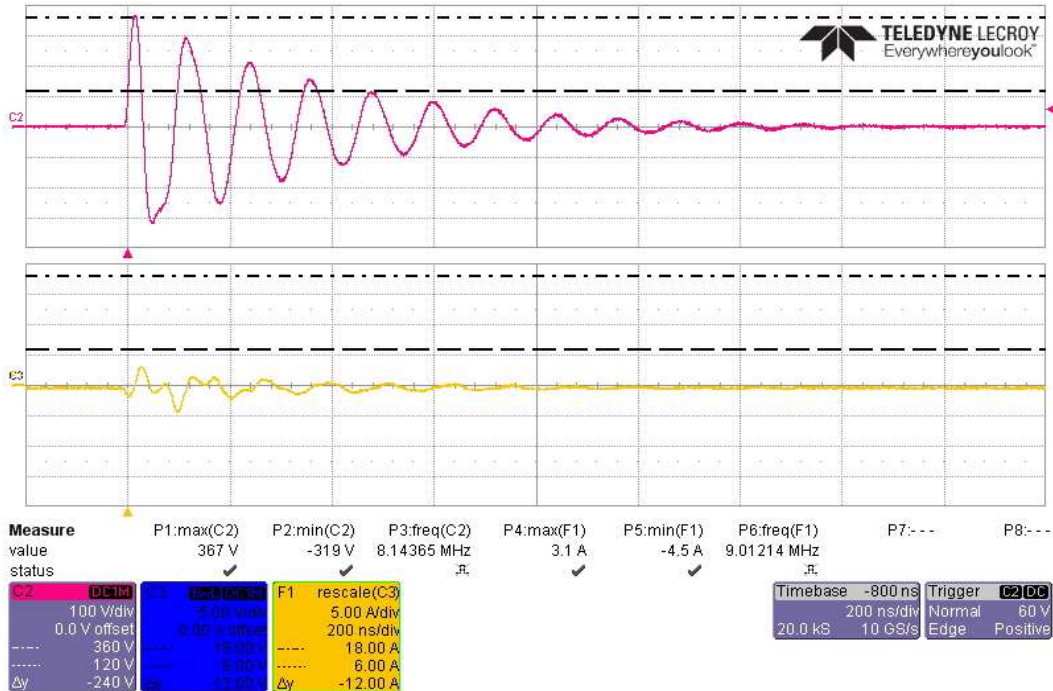

Actual Test CS117 Waveform #3 at 10MHz, First Transient +360V/6A, on PV Return Side

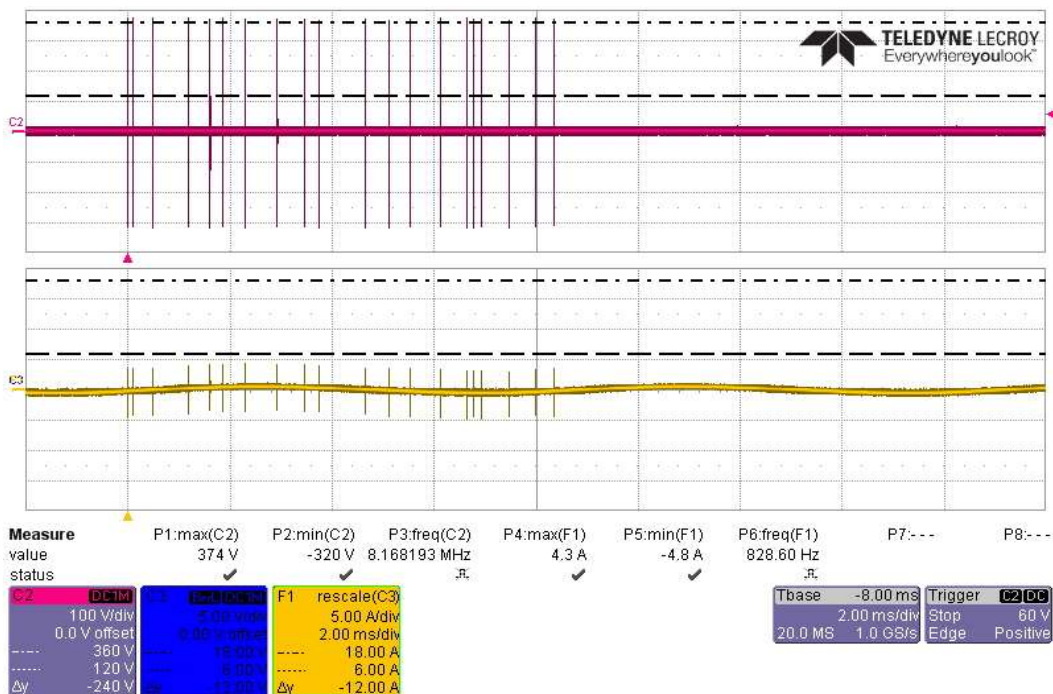

Actual Test CS117 Waveform #3 at 10MHz, 20 Transients +360V/6A, on PV Return Side

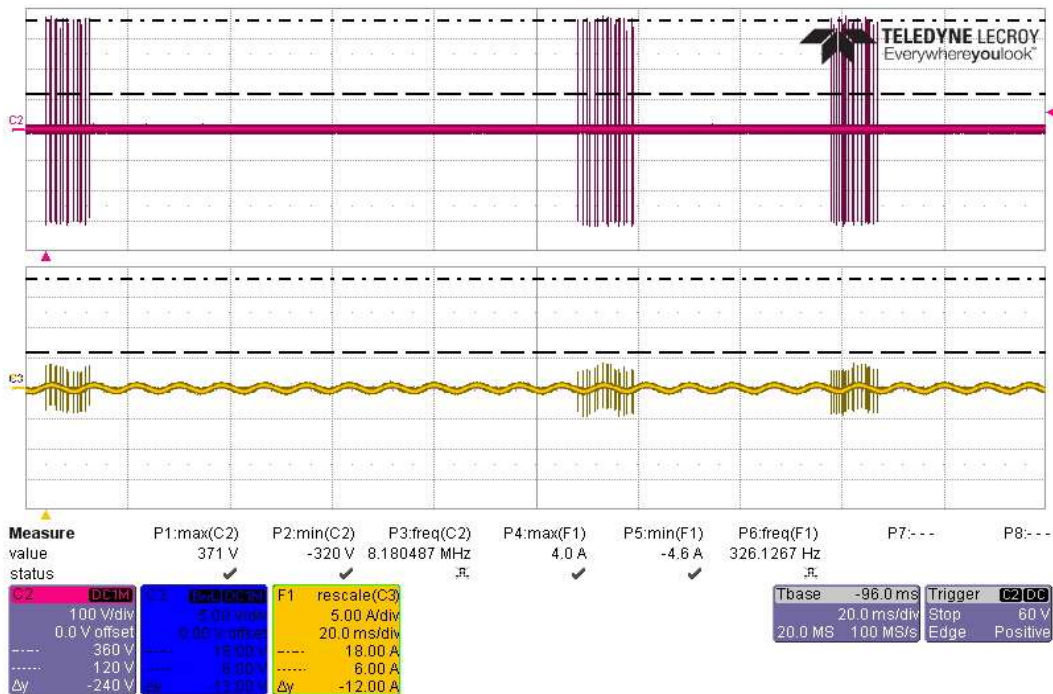

Actual Test CS117 Waveform #3 at 10MHz, 3 Bursts +360V/6A, on PV Return Side

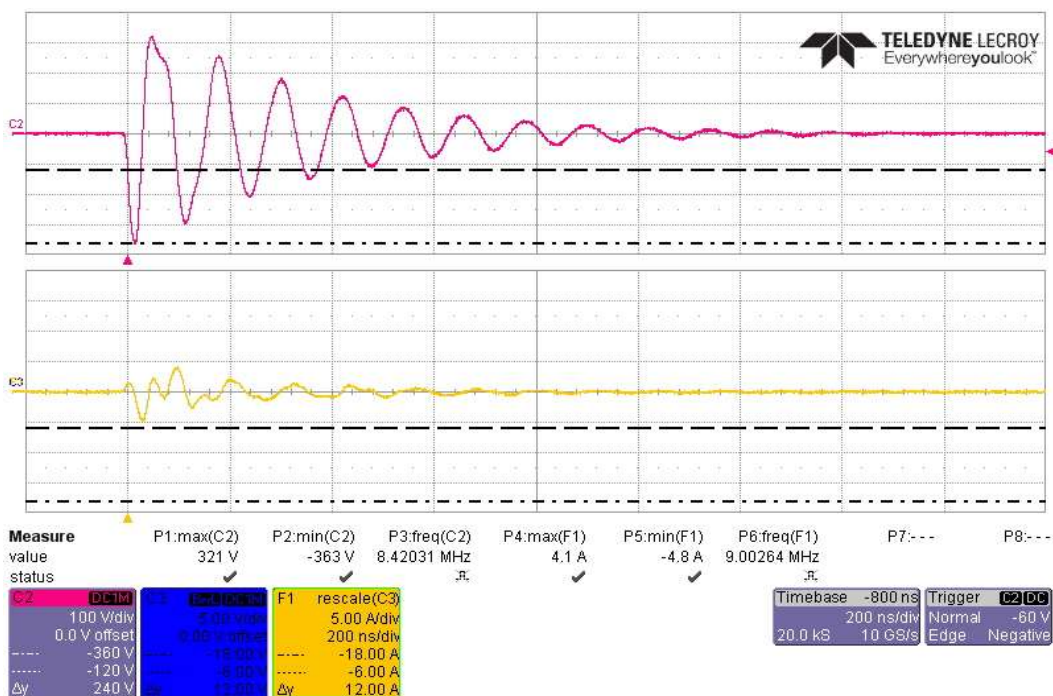

Actual Test CS117 Waveform #3 at 10MHz, First Transient -360V/6A, on PV Return Side

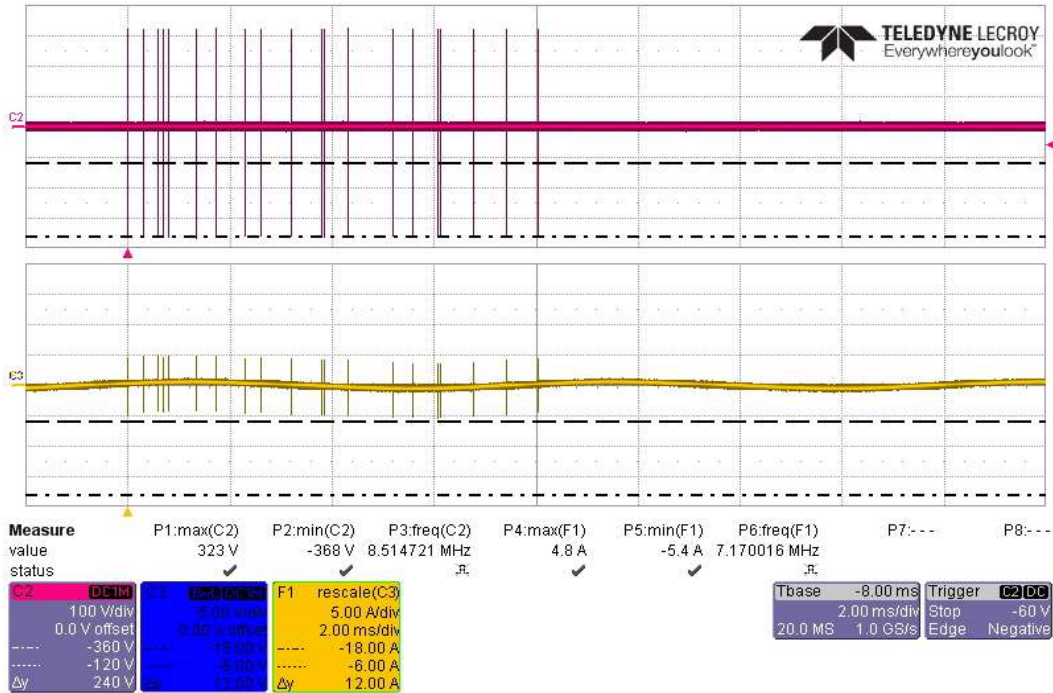

Actual Test CS117 Waveform #3 at 10MHz, 20 Transients -360V/6A, on PV Return Side

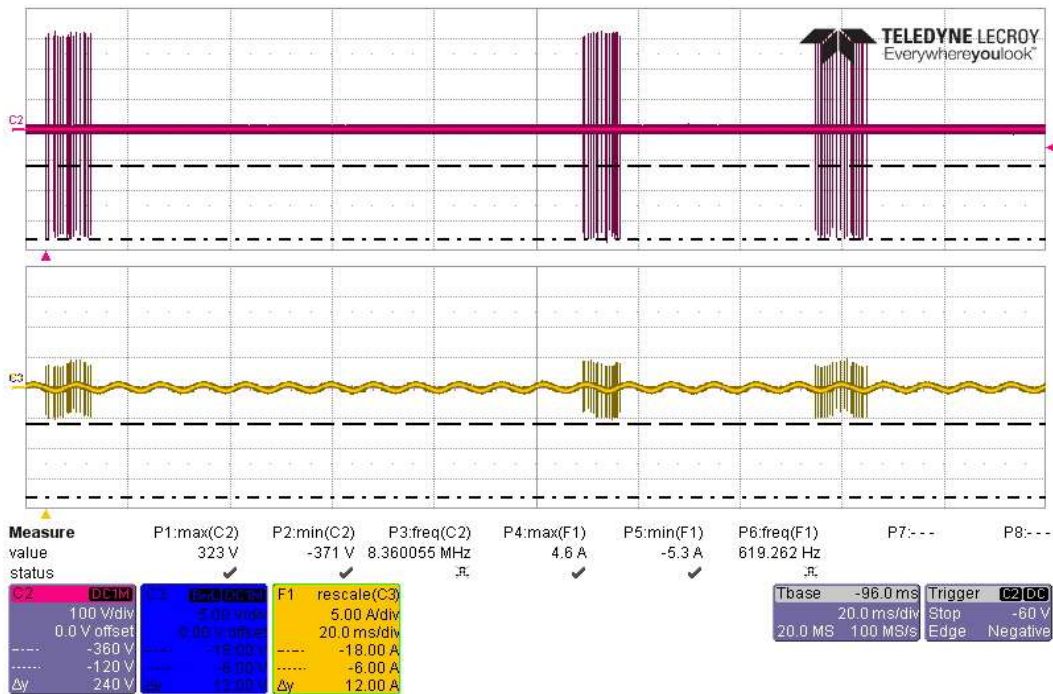

Actual Test CS117 Waveform #3 at 10MHz, 3 Bursts -360V/6A, on PV Return Side

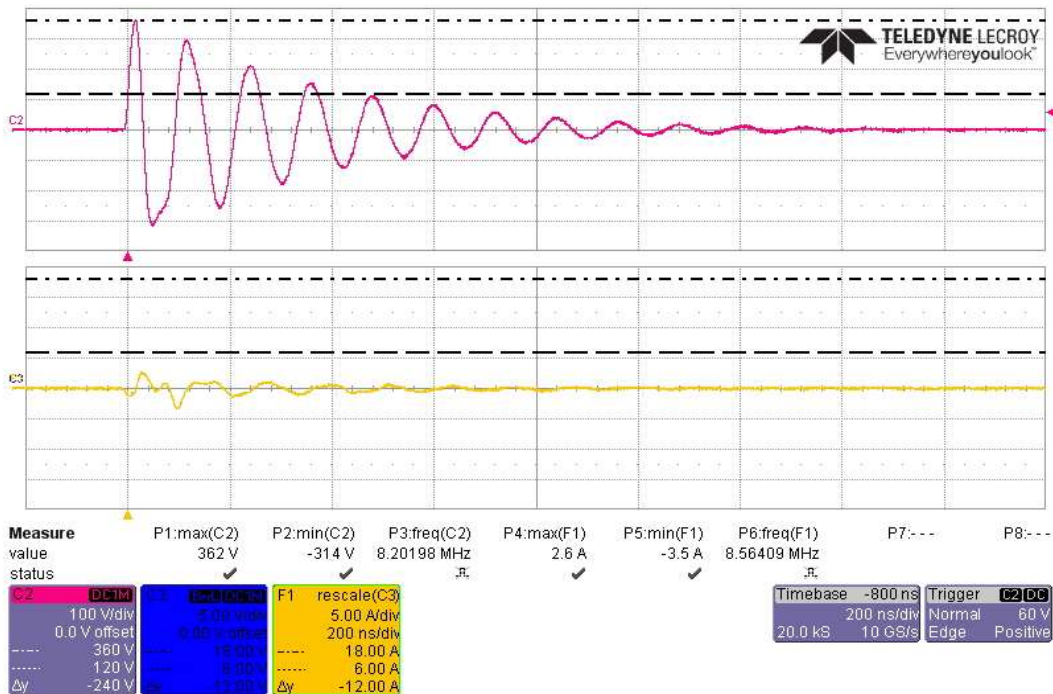

Actual Test CS117 Waveform #3 at 10MHz, First Transient +360V/6A, on PV Bundle

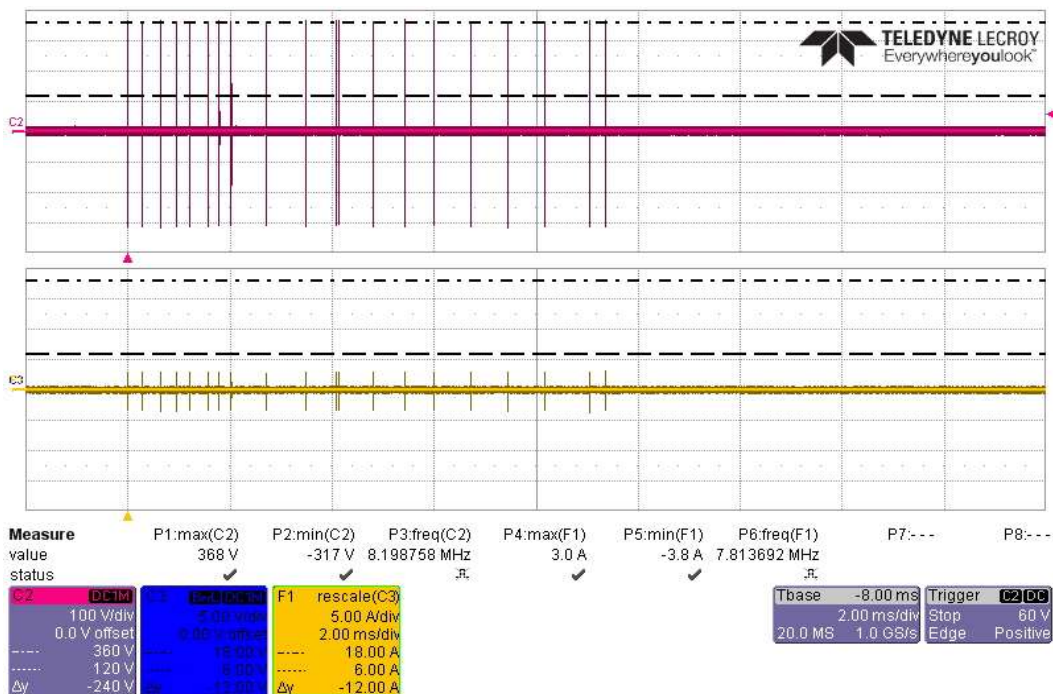

Actual Test CS117 Waveform #3 at 10MHz, 20 Transients +360V/6A, on PV Bundle

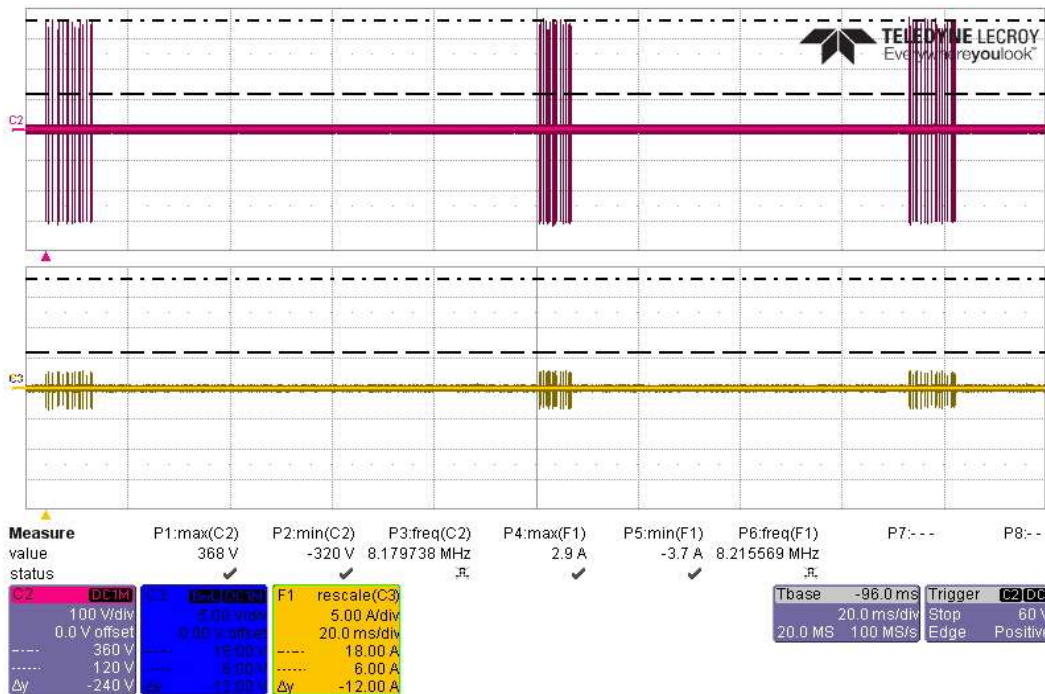

Actual Test CS117 Waveform #3 at 10MHz, 3 Bursts +360V/6A, on PV Bundle

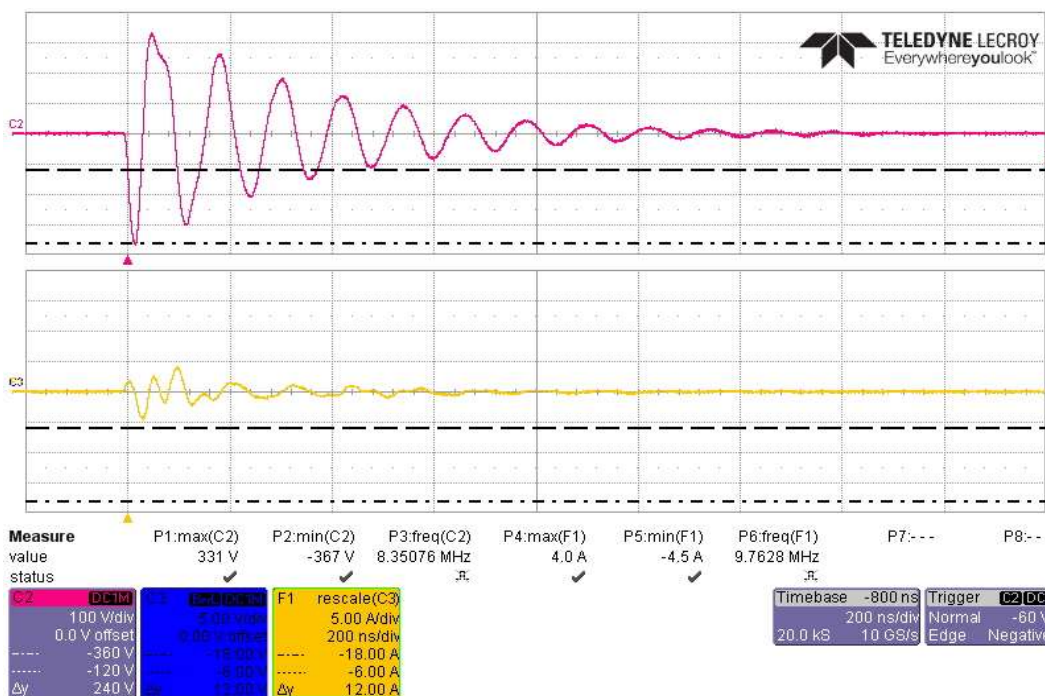

Actual Test CS117 Waveform #3 at 10MHz, First Transient -360V/6A, on PV Bundle

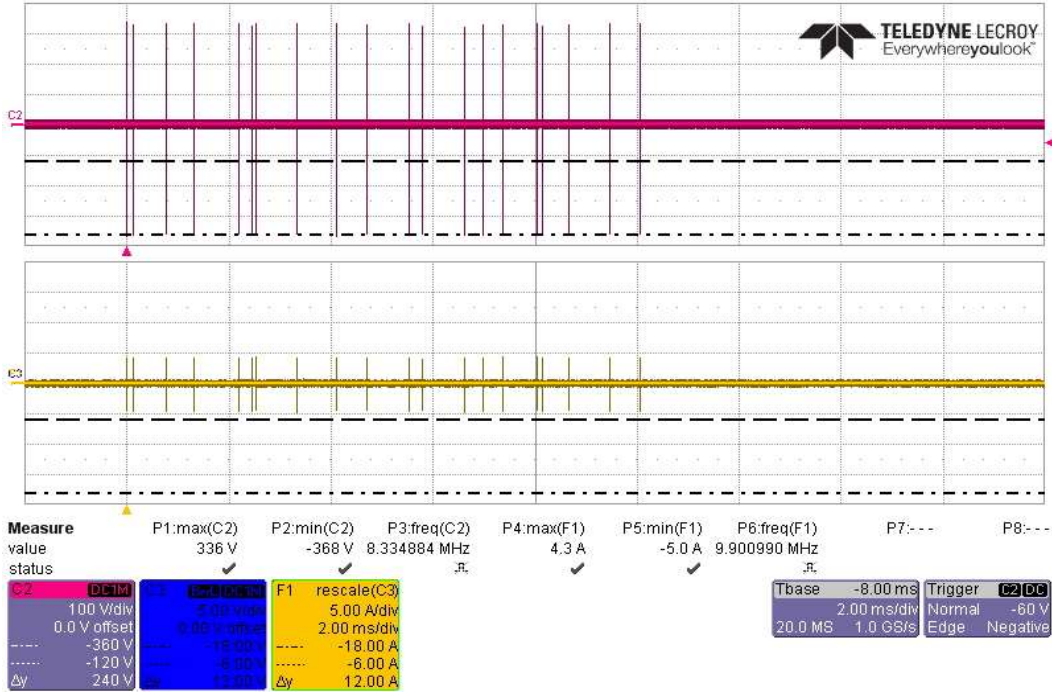

Actual Test CS117 Waveform #3 at 10MHz, 20 Transients -360V/6A, on PV Bundle

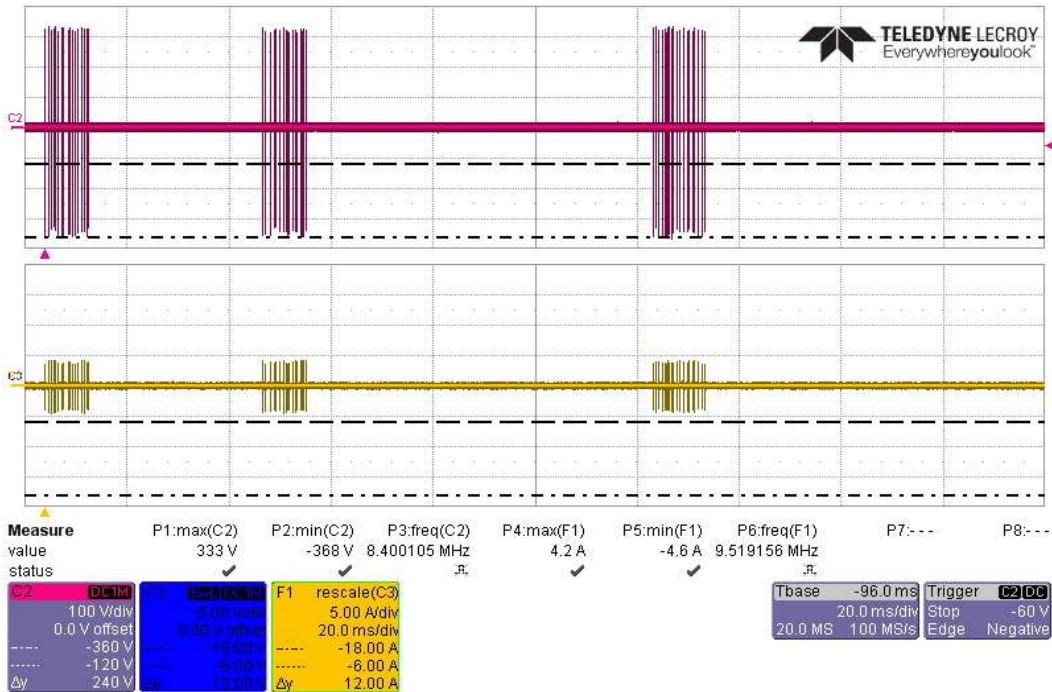

Actual Test CS117 Waveform #3 at 10MHz, 3 Bursts -360V/6A, on PV Bundle

5.3.1 CS117 Test Data on Battery Rack Mount

CUSTOMER:	EG4 Electronics LLC	MJO:	PR183529		
TEST ITEM:	Battery Rack Mount	DATE:	6/27/24		
PART NUMBER:	NA	UNIT NO:	1001511066-V4		
SPECIFICATION:	MIL-STD-461G	CHAMBER NO:	Workbench 1		
EUT Power Input:		DC (Battery Only)			
MIL-STD-461G CS117 Lightning Induced Transient Susceptibility					
Temperature: 85F	Humidity: 42% RH		Barometric Pressure: 981 mBar		
Internal Equipment Levels	Test Level	Test On	Results		Comments
Waveform #1 MS	300VL_60At/150VL_30At	Battery High Side	<input checked="" type="checkbox"/> Pass	<input type="checkbox"/> Fail	
Waveform #1 MS	300VL_60At/150VL_30At	Battery Return Side	<input checked="" type="checkbox"/> Pass	<input type="checkbox"/> Fail	
Waveform #1 MS	300VL_120At/150VL_60At	Battery Bundle	<input type="checkbox"/> Pass	<input type="checkbox"/> Fail	N/A - VL reached 1st - WF2 Required
Waveform #2 MS	300Vt_120AL/150Vt_60AL	Battery Bundle	<input checked="" type="checkbox"/> Pass	<input type="checkbox"/> Fail	
Waveform #3 MS at 1MHz & 10MHz	600V_24A/300V_12A	Battery High Side	<input checked="" type="checkbox"/> Pass	<input type="checkbox"/> Fail	
Waveform #3 MS at 1MHz & 10MHz	600V_24A/300V_12A	Battery Return Side	<input checked="" type="checkbox"/> Pass	<input type="checkbox"/> Fail	
Waveform #3 MS at 1MHz & 10MHz	600V_48A/300V_24A	Battery Bundle	<input checked="" type="checkbox"/> Pass	<input type="checkbox"/> Fail	
Waveform #3 MB at 1MHz & 10MHz	360Vt_6AL	Battery High Side	<input checked="" type="checkbox"/> Pass	<input type="checkbox"/> Fail	
Waveform #3 MB at 1MHz & 10MHz	360Vt_6AL	Battery Return Side	<input checked="" type="checkbox"/> Pass	<input type="checkbox"/> Fail	
Waveform #3 MB at 1MHz & 10MHz	360Vt_6AL	Battery Bundle	<input checked="" type="checkbox"/> Pass	<input type="checkbox"/> Fail	
TECHNICIAN / ENGINEER:		Donald Adams	DATE:	6/28/2024	

CS117 Actual Test Multiple Stroke Current Waveform #1 at 60A

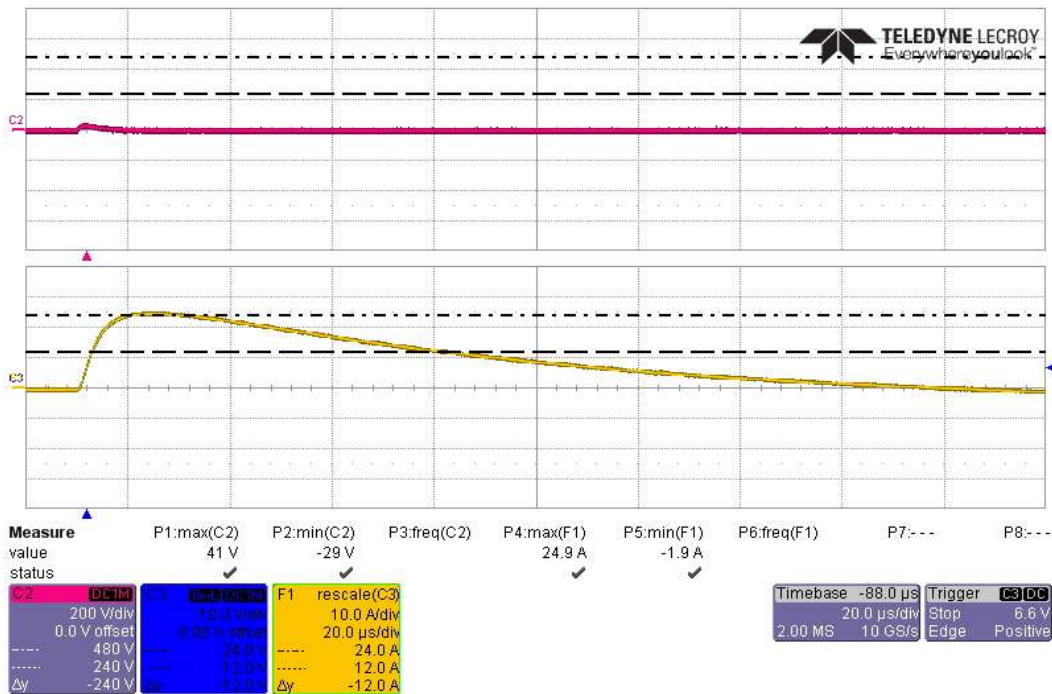

Actual Test CS117 Waveform #1, First Transient +60A, on Battery High Side

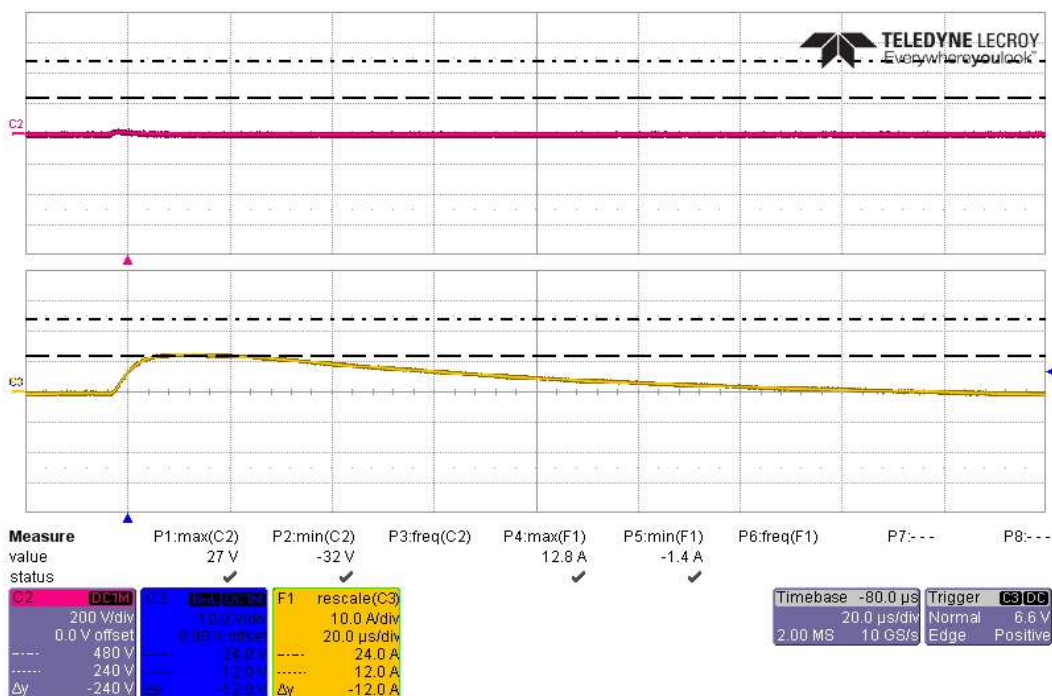

Actual Test CS117 Waveform #1, Subsequent Transient +30A, on Battery High Side

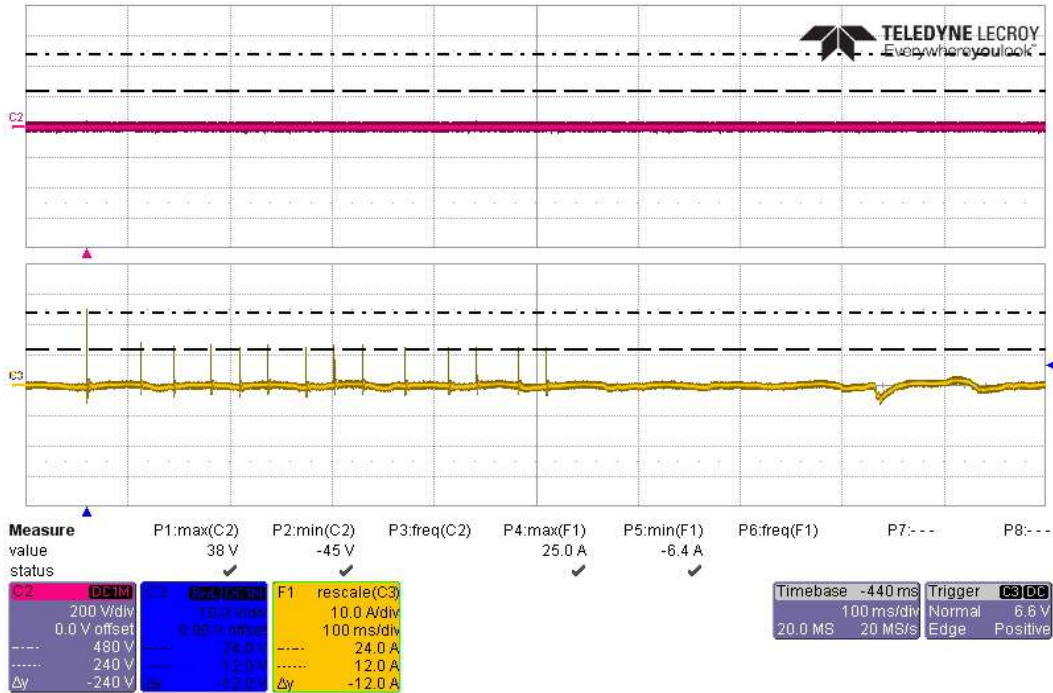

Actual Test CS117 Waveform #1, 14 Transients +60A/30A, on Battery High Side

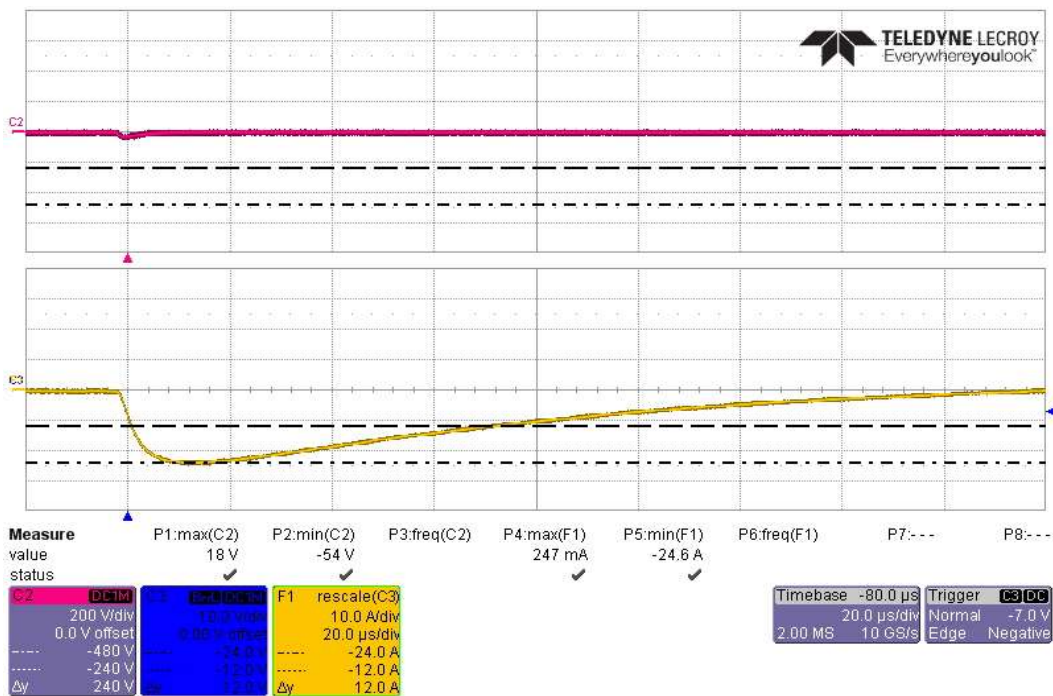

Actual Test CS117 Waveform #1, First Transient -60A, on Battery High Side

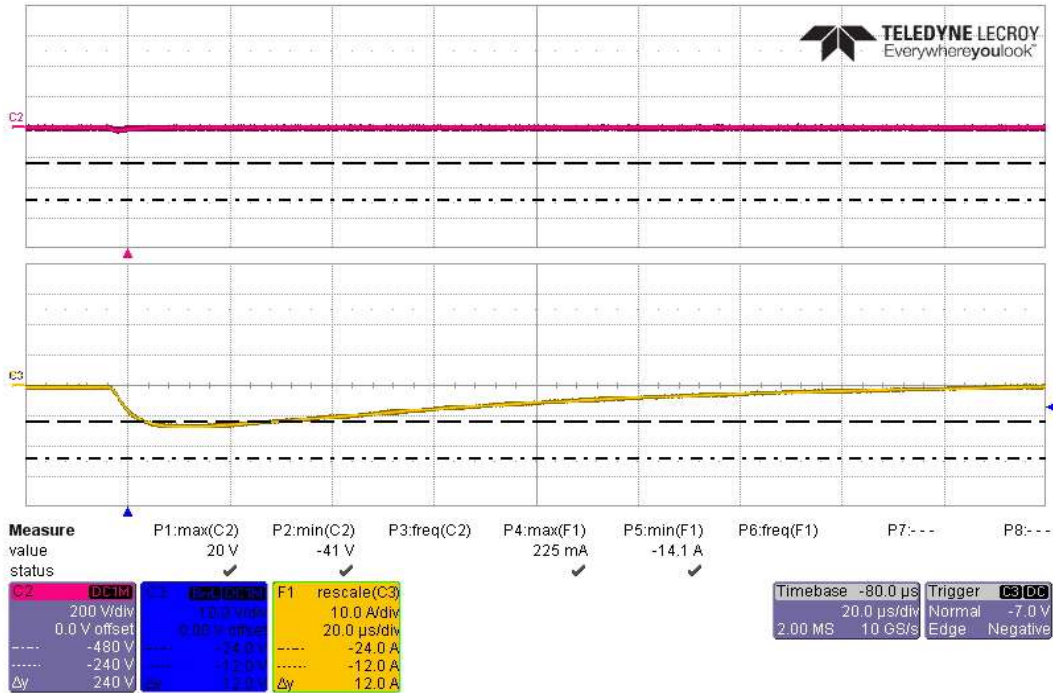

Actual Test CS117 Waveform #1, Subsequent Transient -30A, on Battery High Side

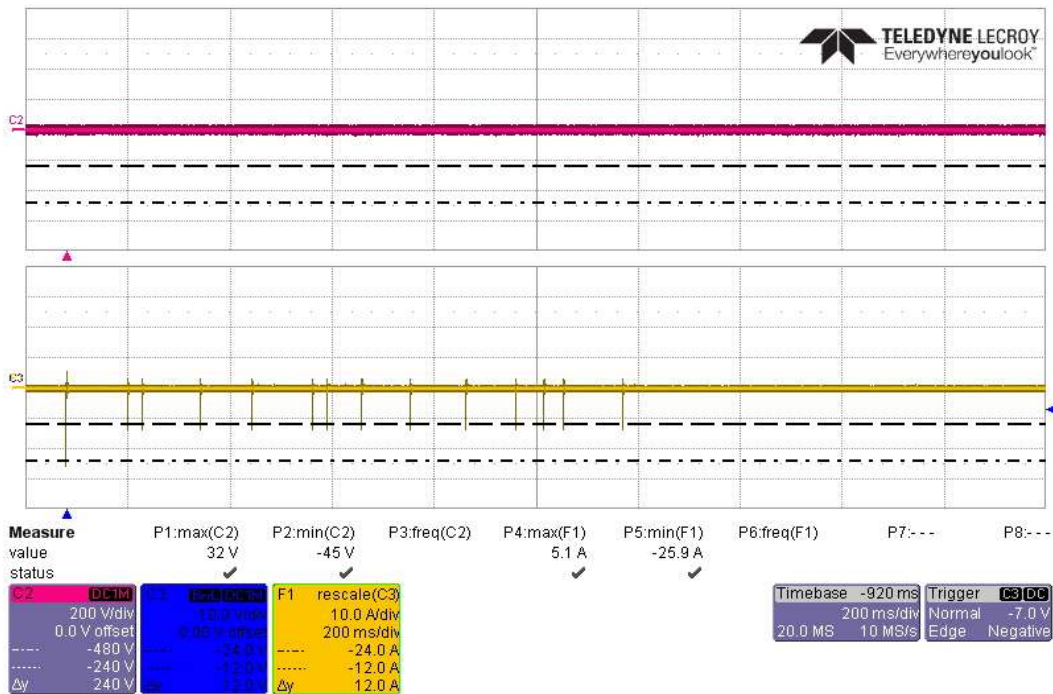

Actual Test CS117 Waveform #1, 14 Transients -60A/30A, on Battery High Side

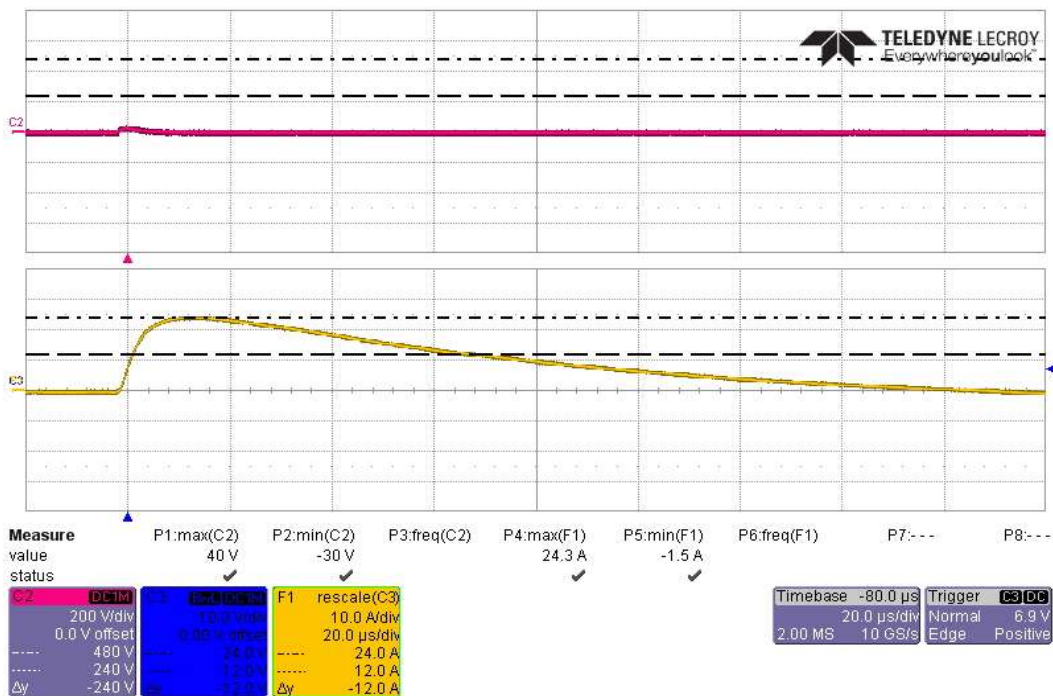

Actual Test CS117 Waveform #1, First Transient +60A, on Battery Return Side

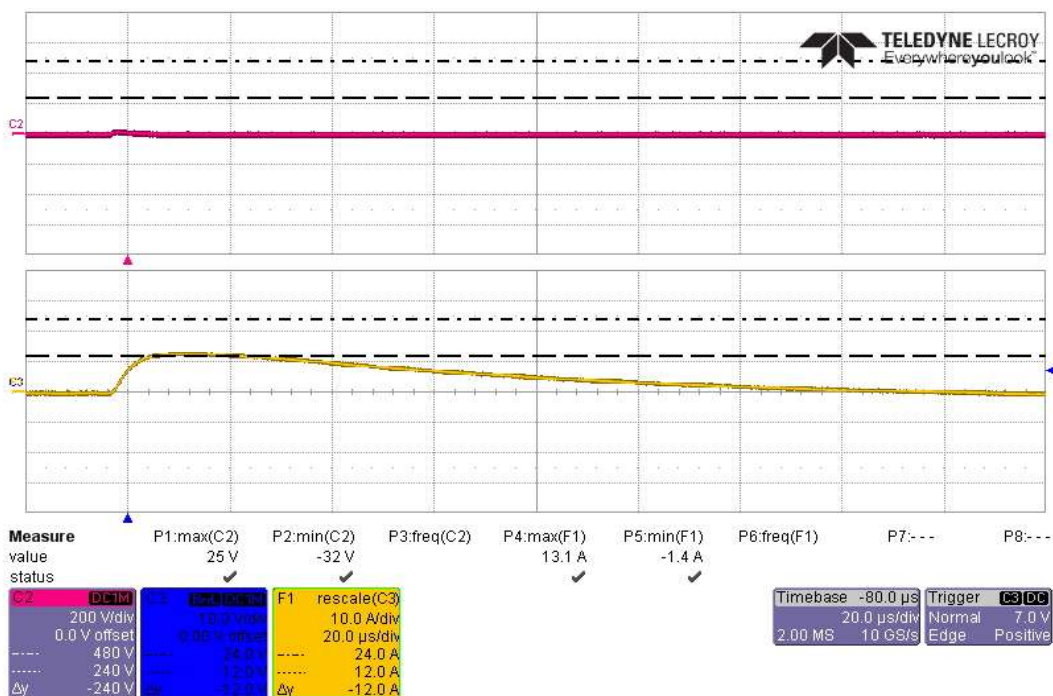

Actual Test CS117 Waveform #1, Subsequent Transient +30A, on Battery Return Side

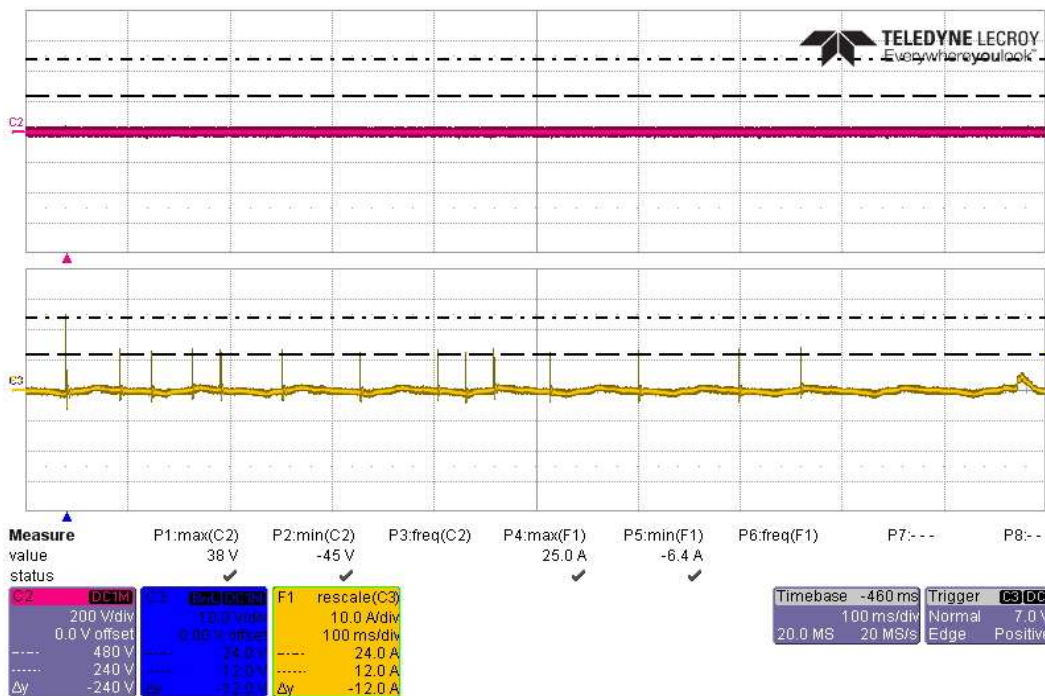

Actual Test CS117 Waveform #1, 14 Transients +60A/30A, on Battery Return Side

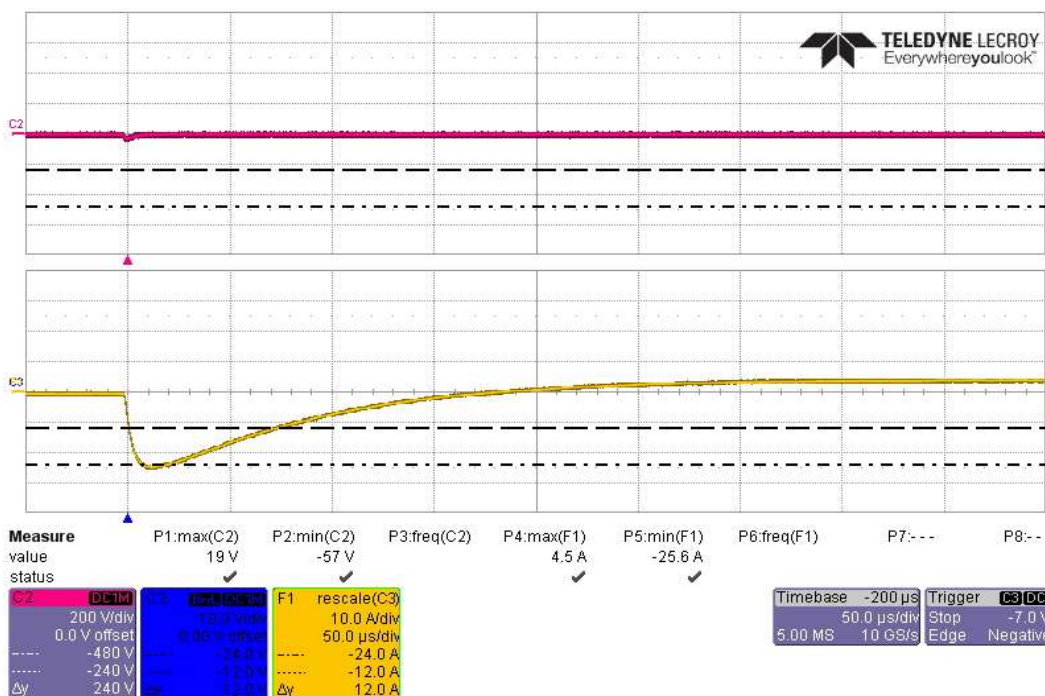

Actual Test CS117 Waveform #1, First Transient -60A, on Battery Return Side

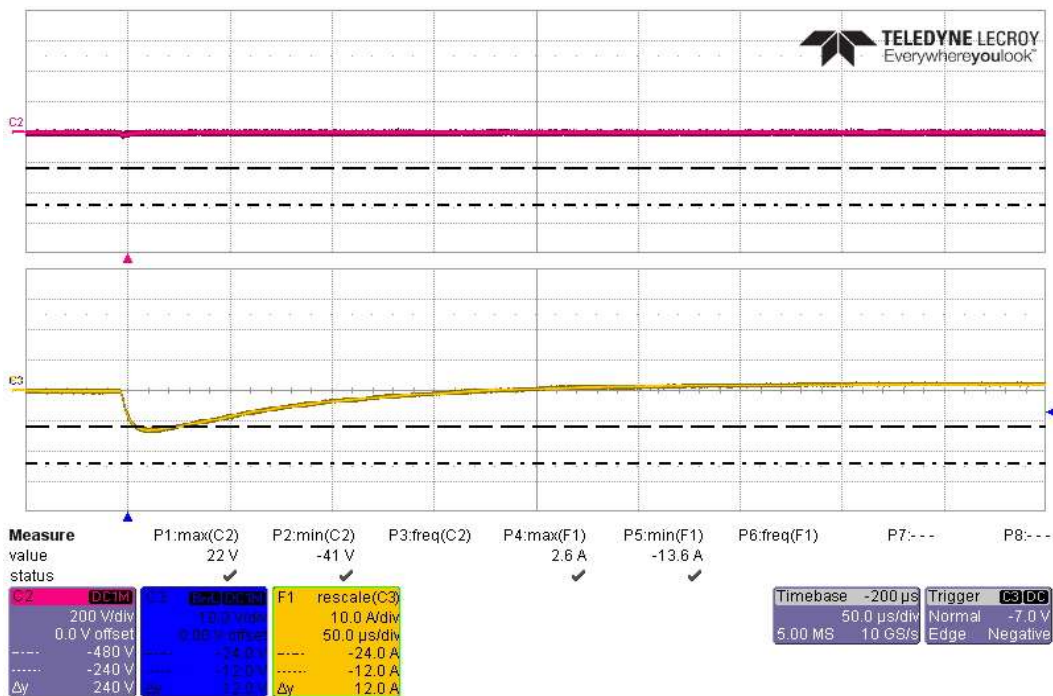

Actual Test CS117 Waveform #1, Subsequent Transient -30A, on Battery Return Side

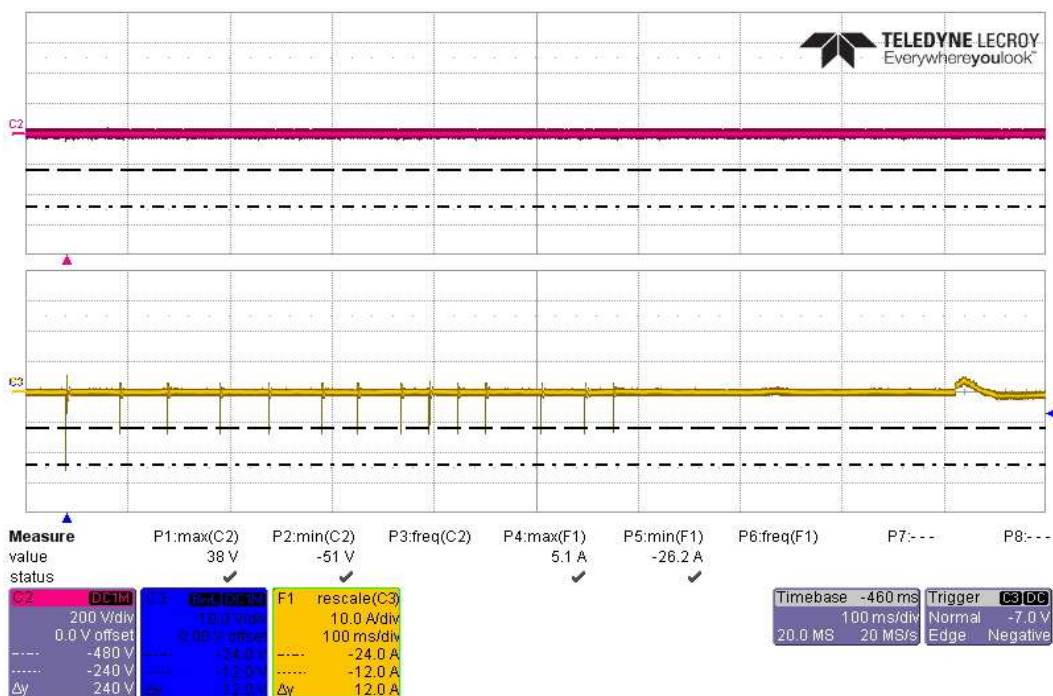

Actual Test CS117 Waveform #1, 14 Transients -60A/30A, on Battery Return Side

CS117 Actual Multiple Stroke Voltage Waveform #2 Test at 300V

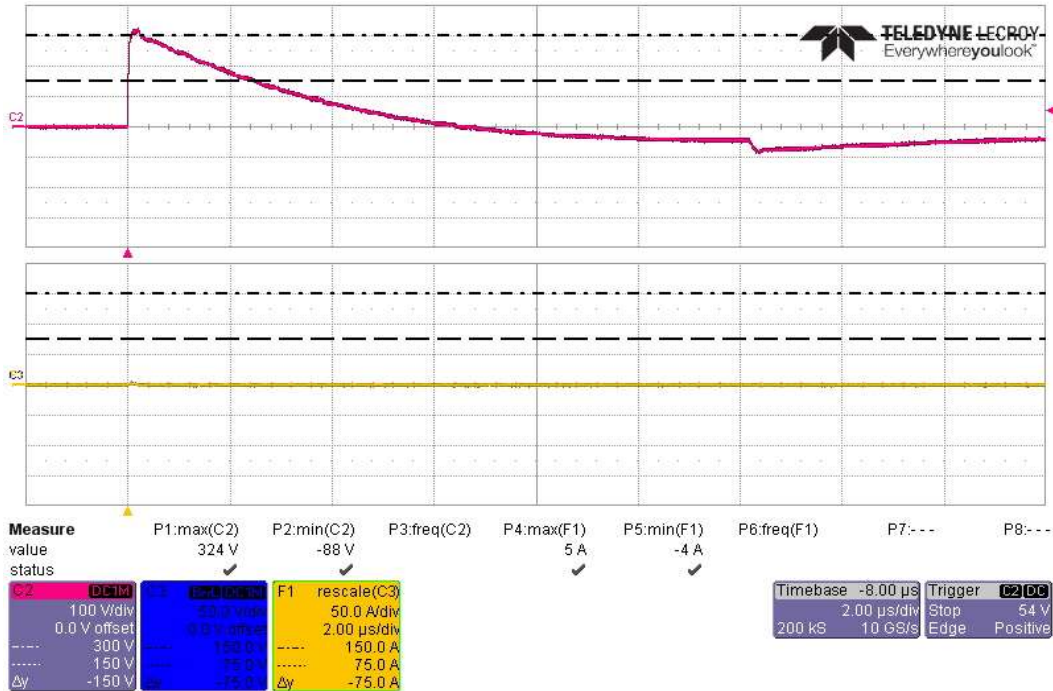

Actual CS117 Voltage Waveform #2 Test, First Transient +300V/120A on Battery Bundle

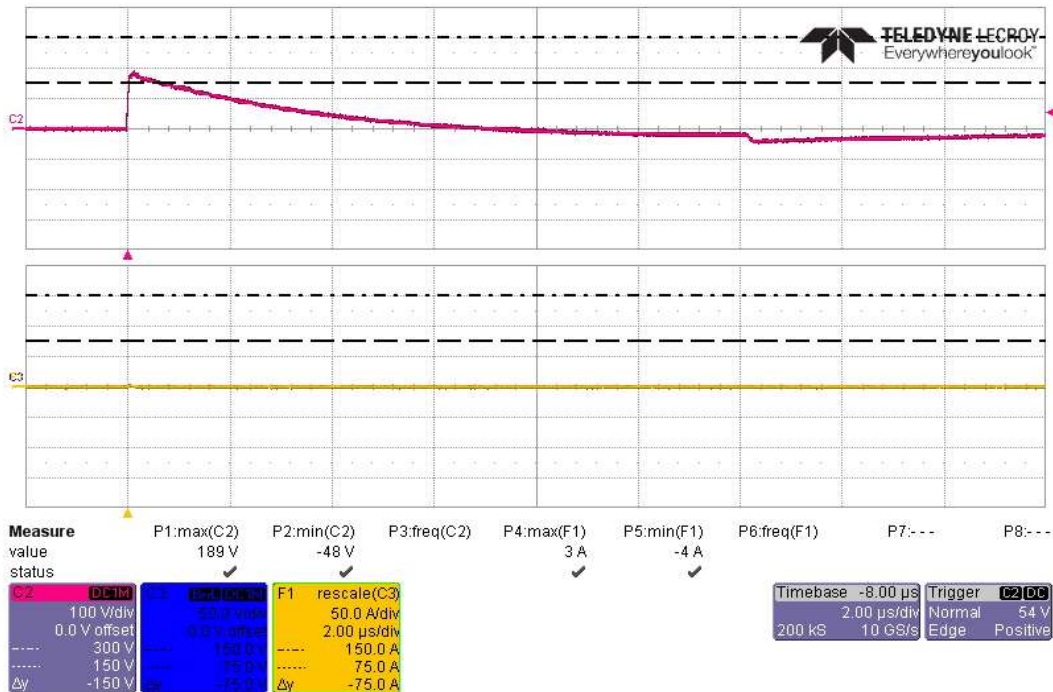

Actual CS117 Voltage Waveform #2 Test, Subsequent Transient +150V/60A on Battery Bundle

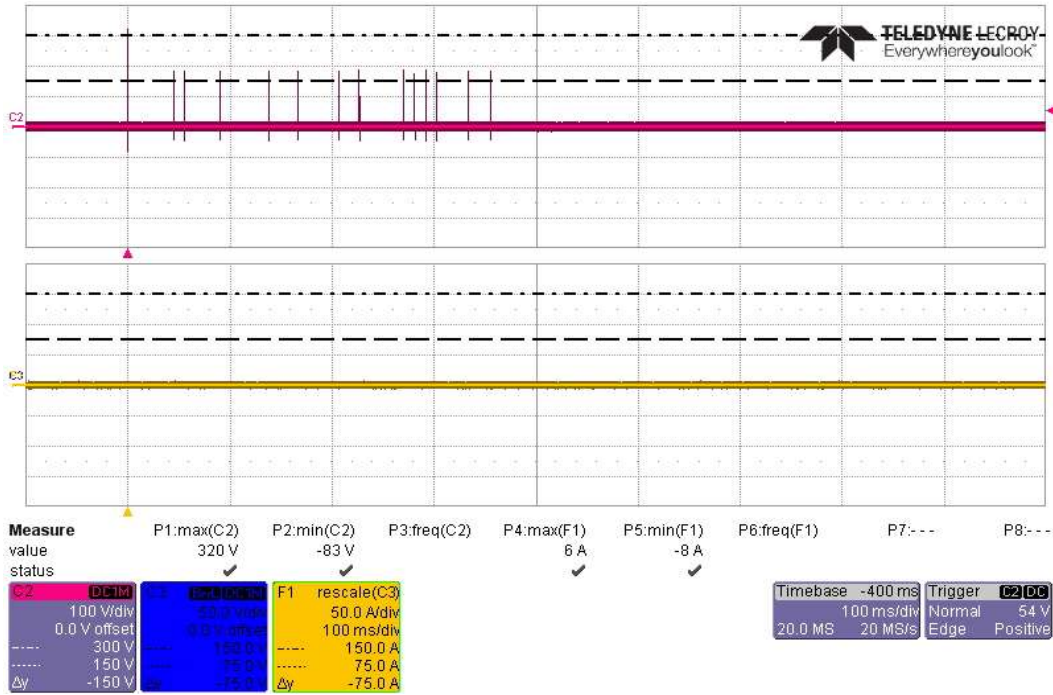

Actual CS117 Voltage Waveform #2 Test, 14 Transient +300V/120A & +150V/60A on Battery Bundle

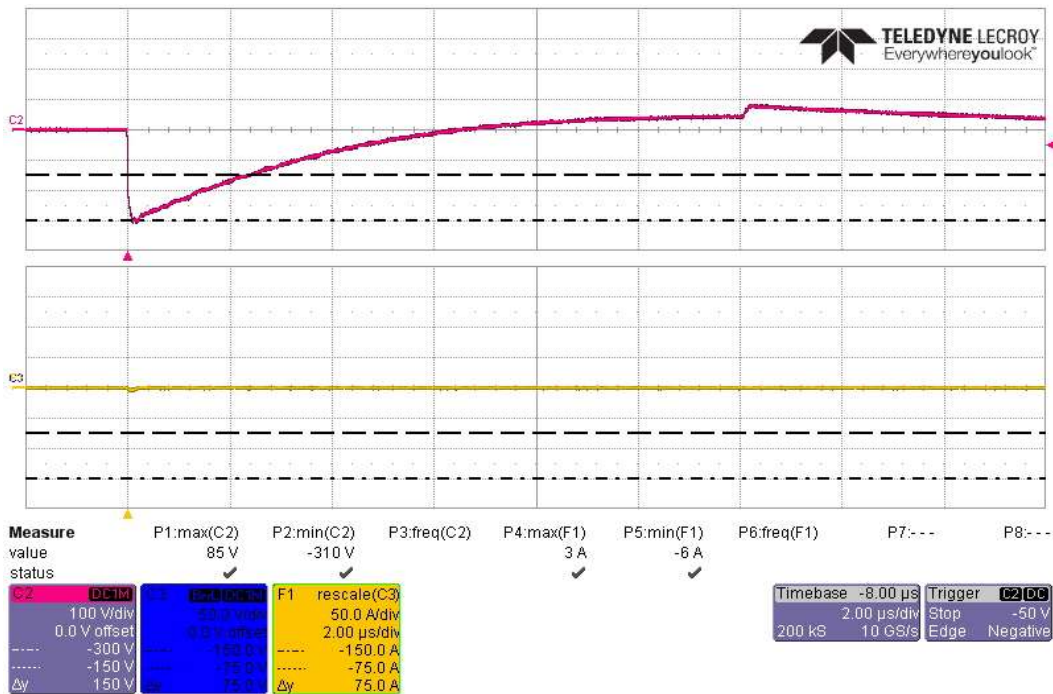

Actual CS117 Voltage Waveform #2 Test, First Transient -300V/120A on Battery Bundle

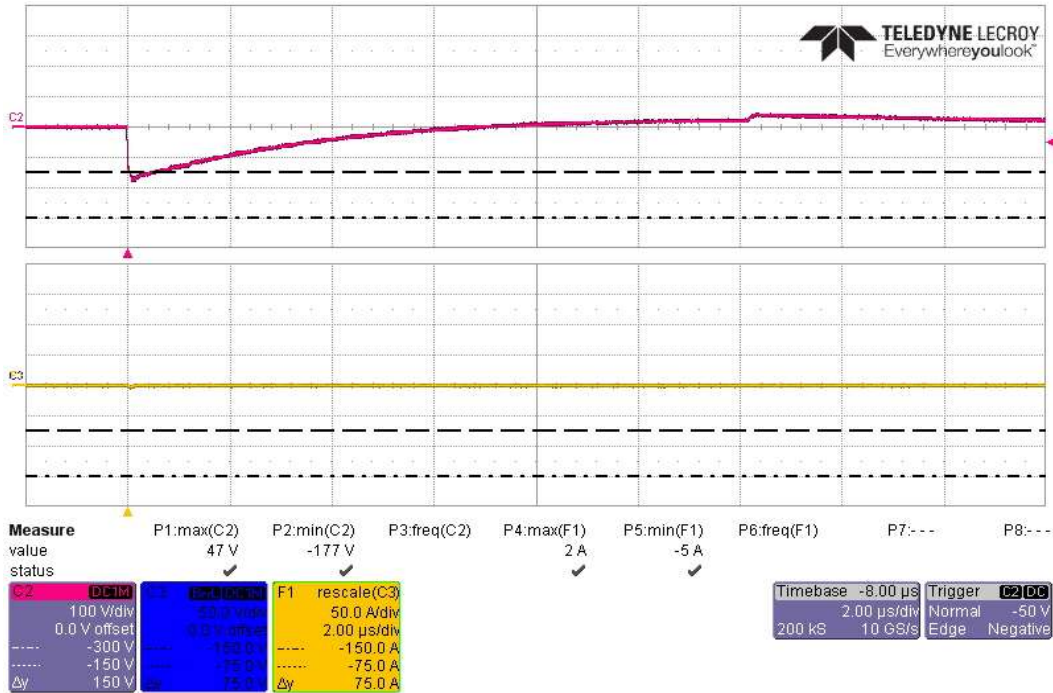

Actual CS117 Voltage Waveform #2 Test, Subsequent Transient -150V/60A on Battery Bundle

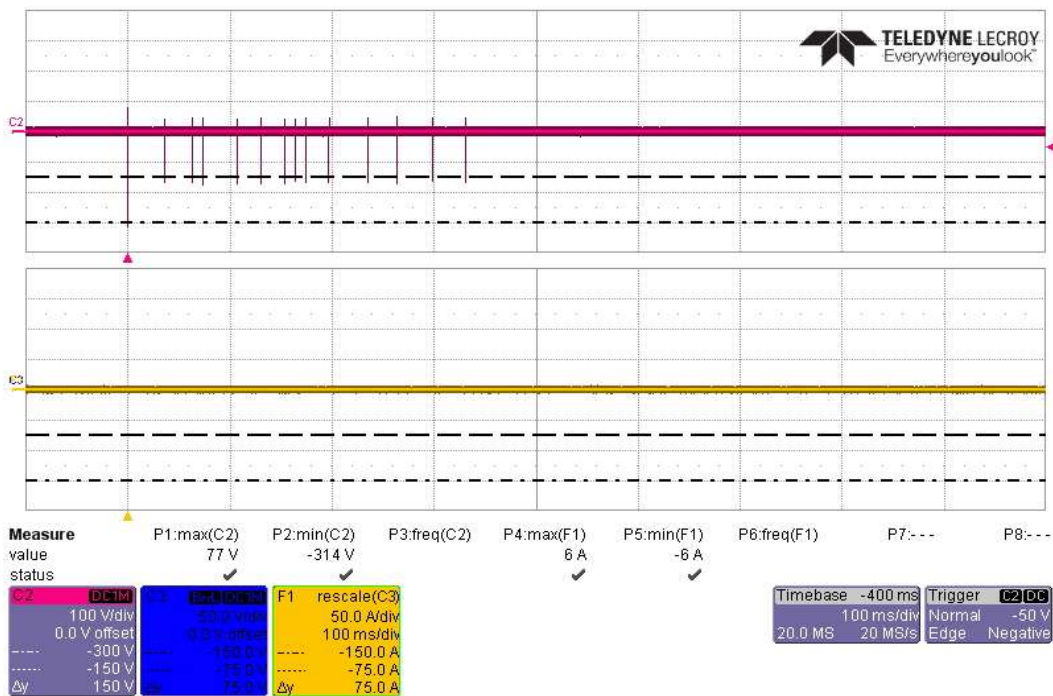

Actual CS117 Voltage Waveform #2 Test, 14 Transient -300V/120A & -150V/60A on Battery Bundle

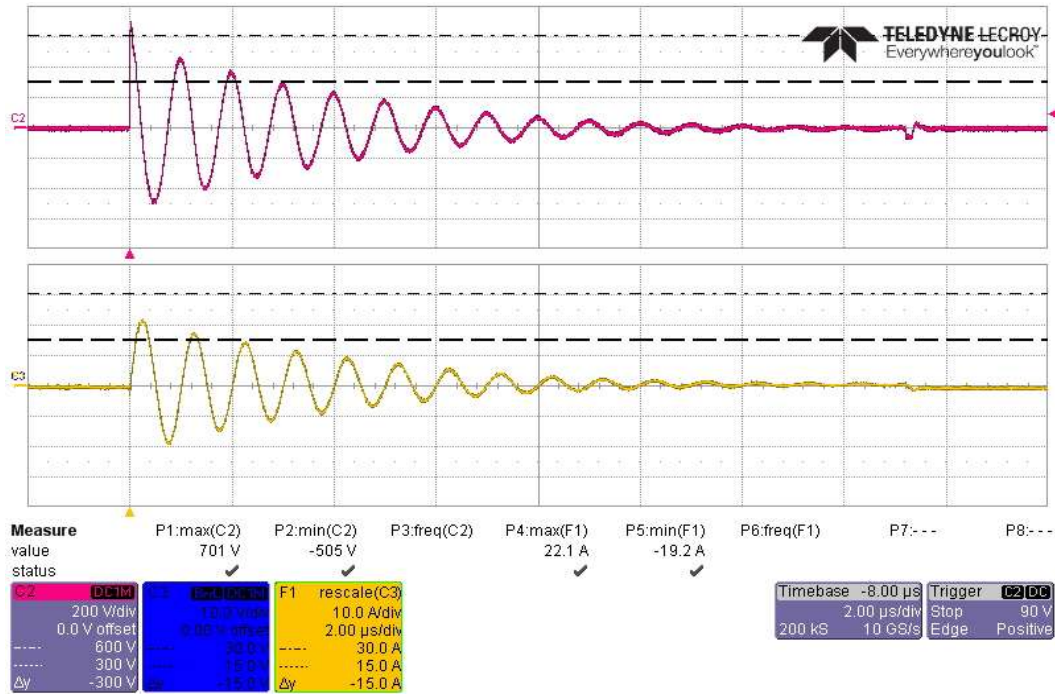
CS117 Actual Test Waveform #3 at 1MHz with 600V/24A

Actual Test CS117 Waveform #3 at 1MHz, First Transient +600V, on Battery High Side

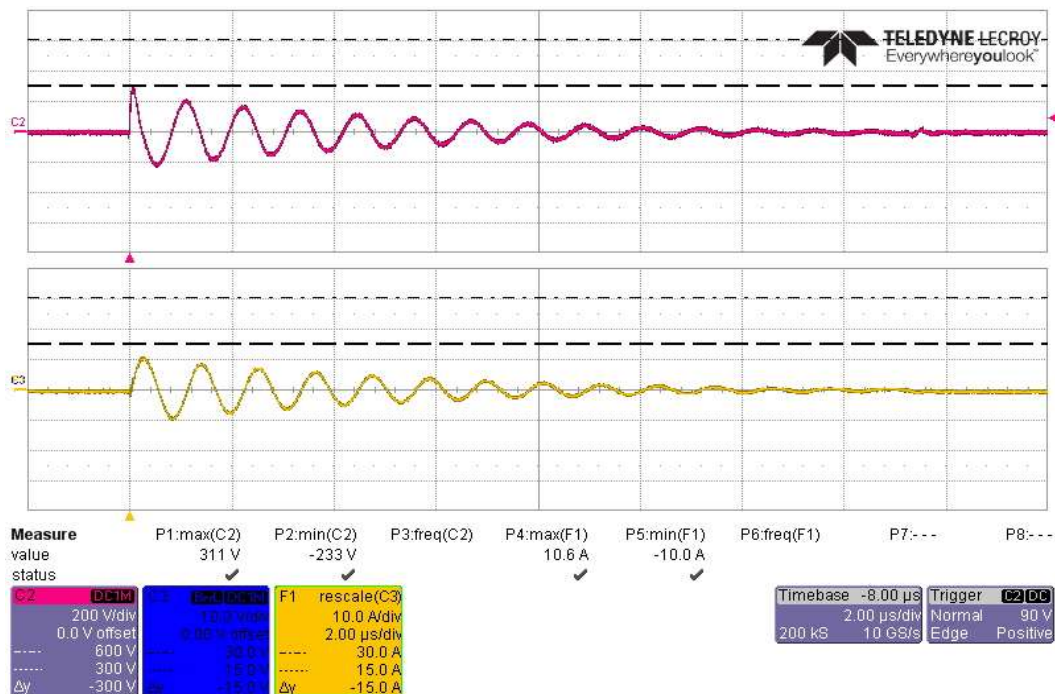

Actual Test CS117 Waveform #3 at 1MHz, Subsequent Transient +300V, on Battery High Side

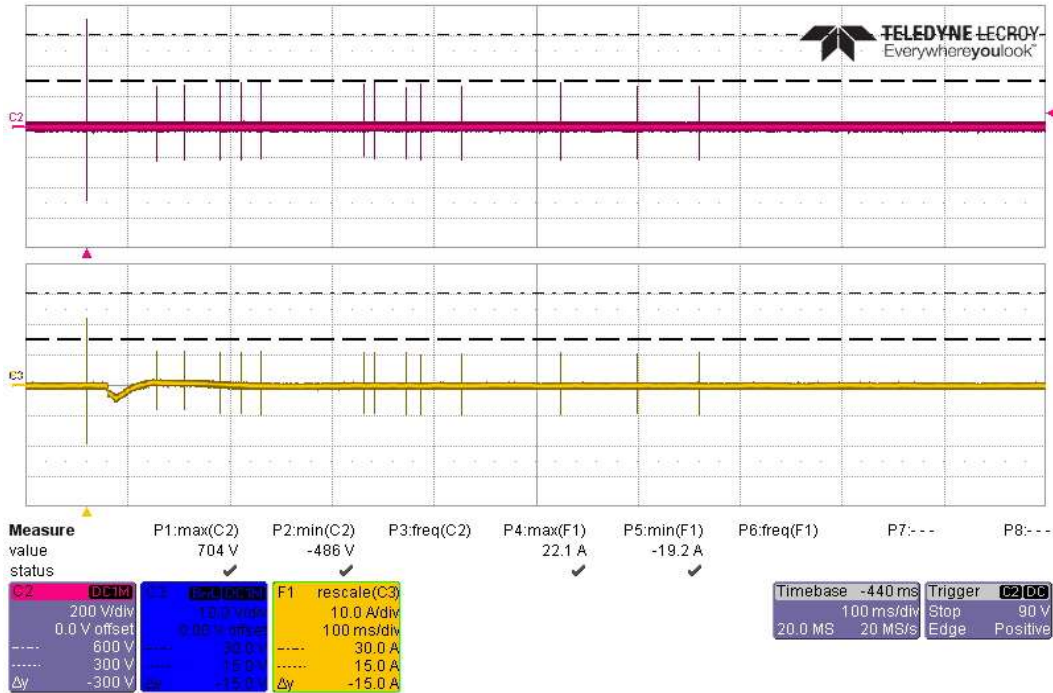

Actual Test CS117 Waveform #3 at 1MHz, 14 Transients +600/+300V, on Battery High Side

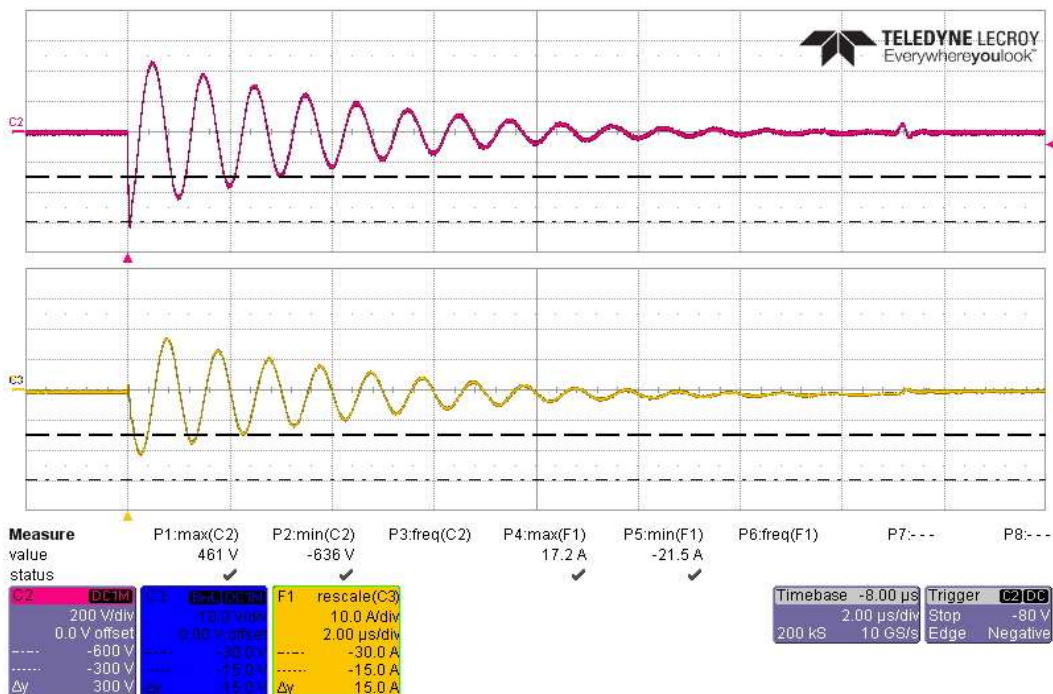

Actual Test CS117 Waveform #3 at 1MHz, First Transient -600V, on Battery High Side

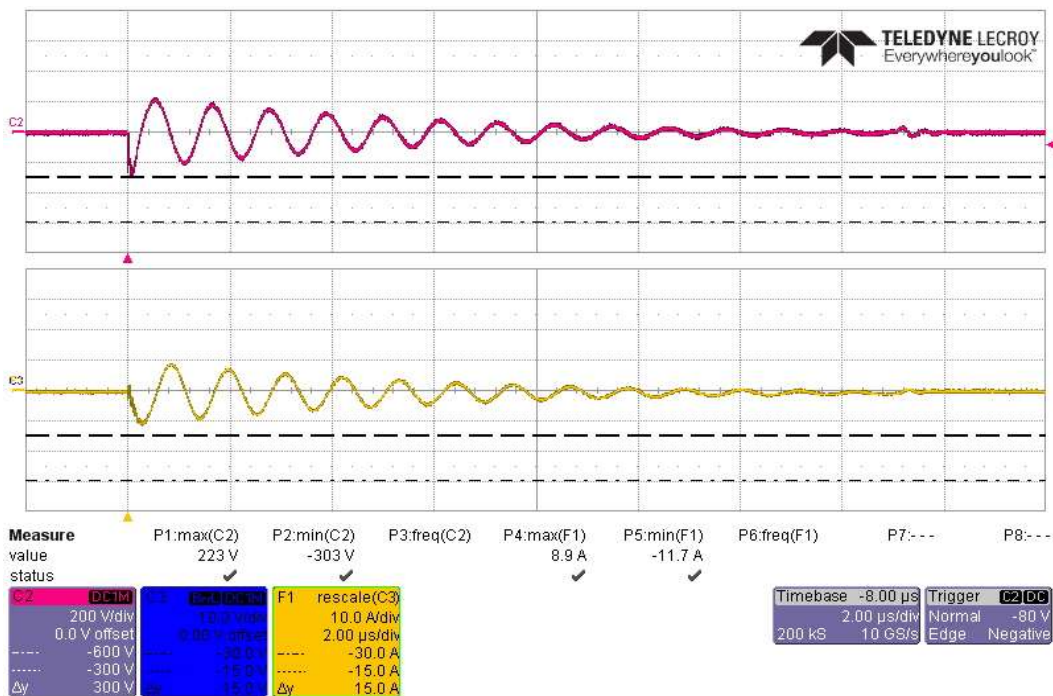

Actual Test CS117 Waveform #3 at 1MHz, Subsequent Transient -300V, on Battery High Side

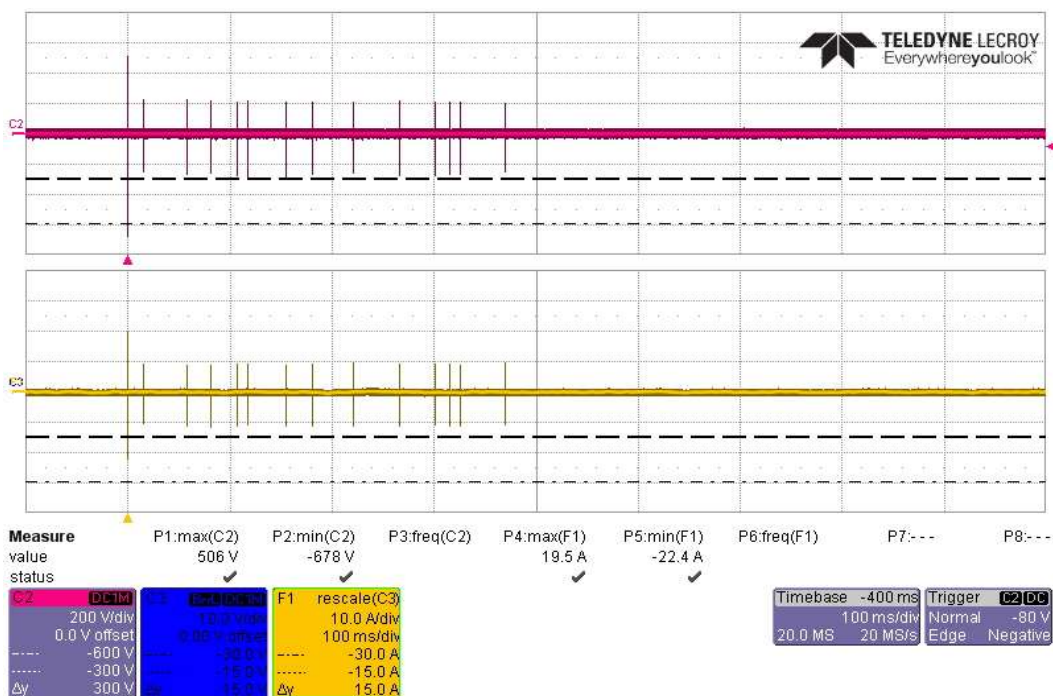

Actual Test CS117 Waveform #3 at 1MHz, 14 Transients -600/-300V, on Battery High Side

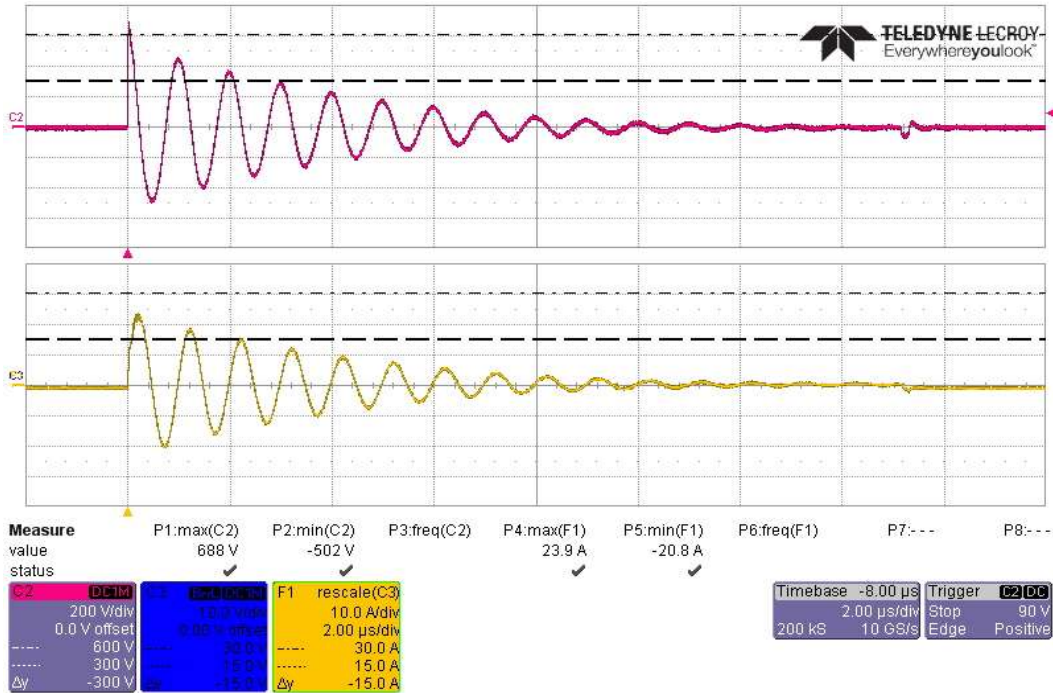

Actual Test CS117 Waveform #3 at 1MHz, First Transient +600V, on Battery Return Side

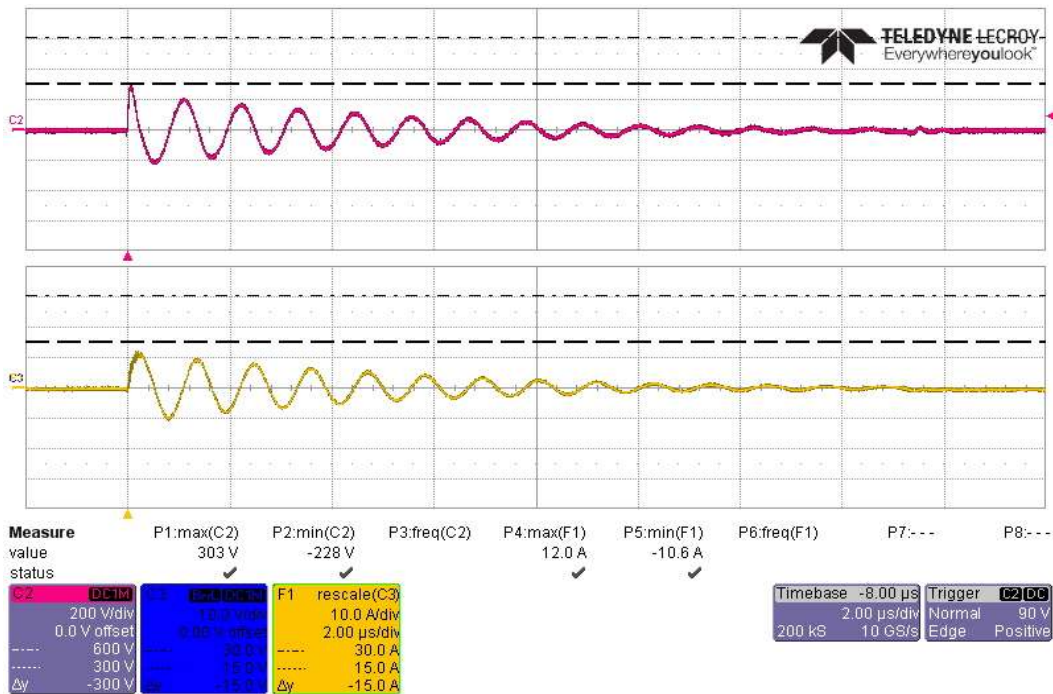

Actual Test CS117 Waveform #3 at 1MHz, Subsequent Transient +300V, on Battery Return Side

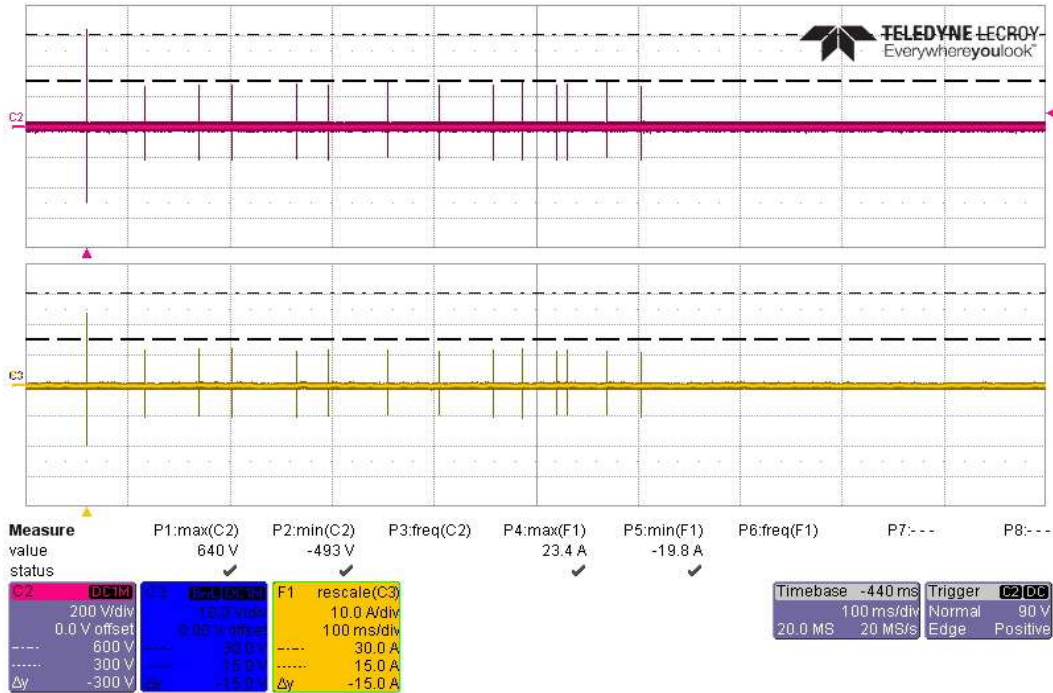

Actual Test CS117 Waveform #3 at 1MHz, 14 Transients +600/+300V, on Battery Return Side

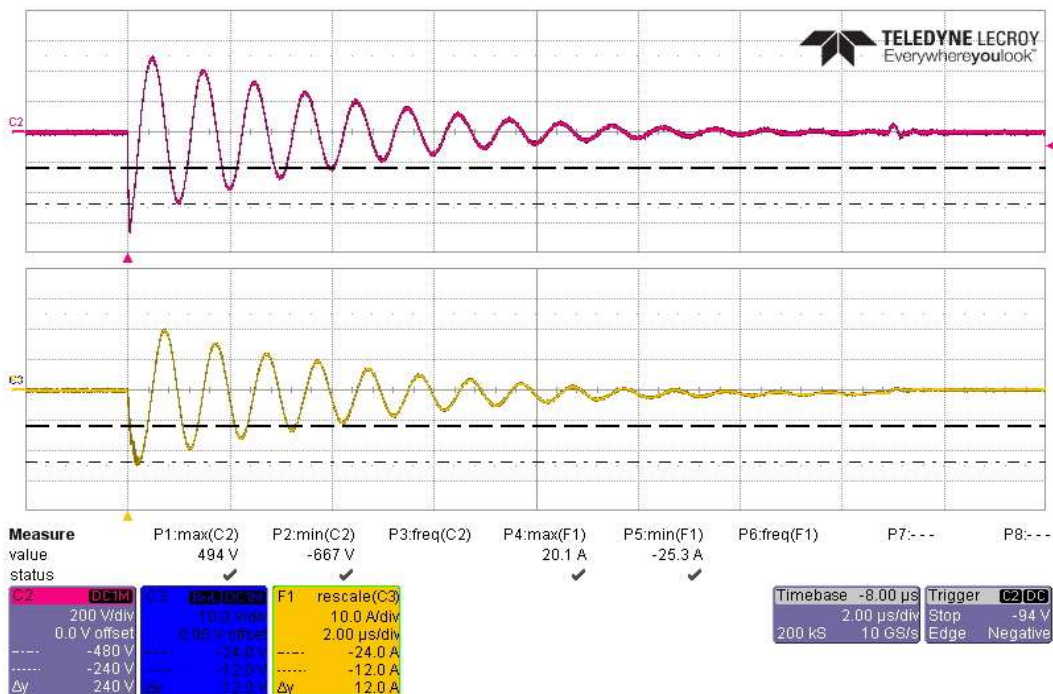

Actual Test CS117 Waveform #3 at 1MHz, First Transient -600V, on Battery Return Side

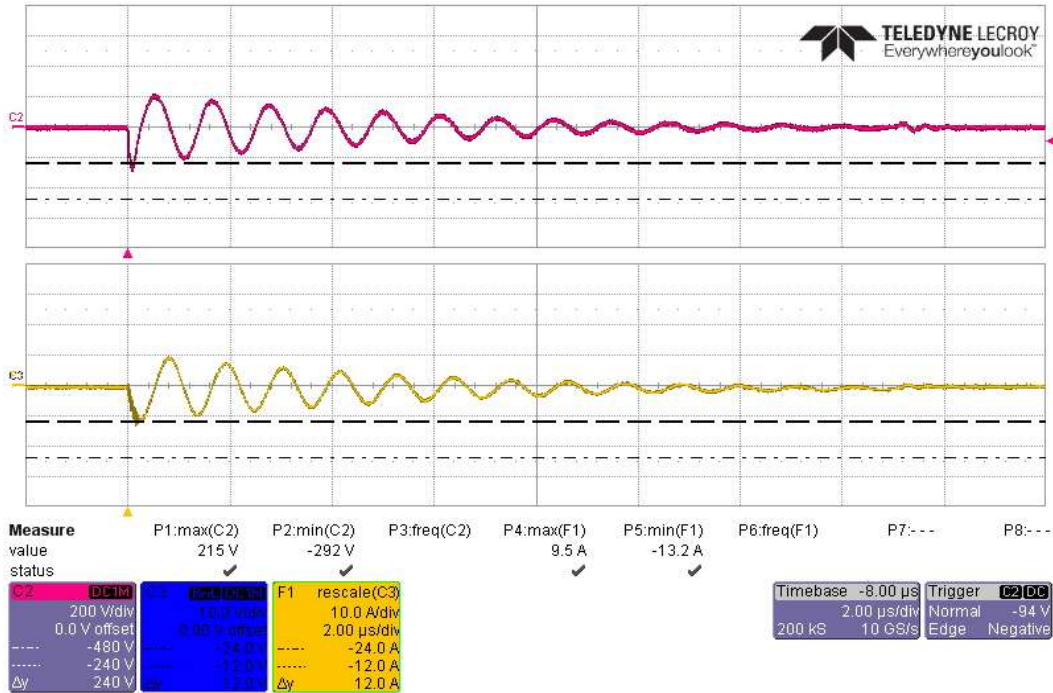

Actual Test CS117 Waveform #3 at 1MHz, Subsequent Transient -300V, on Battery Return Side

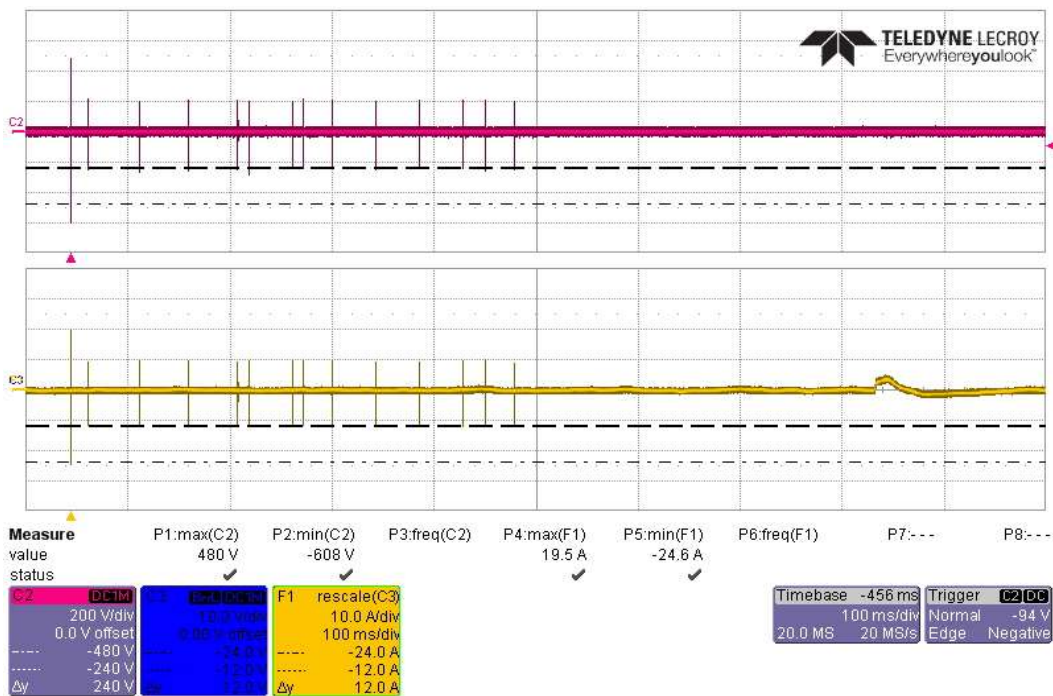

Actual Test CS117 Waveform #3 at 1MHz, 14 Transients -600/-300V, on Battery Return Side

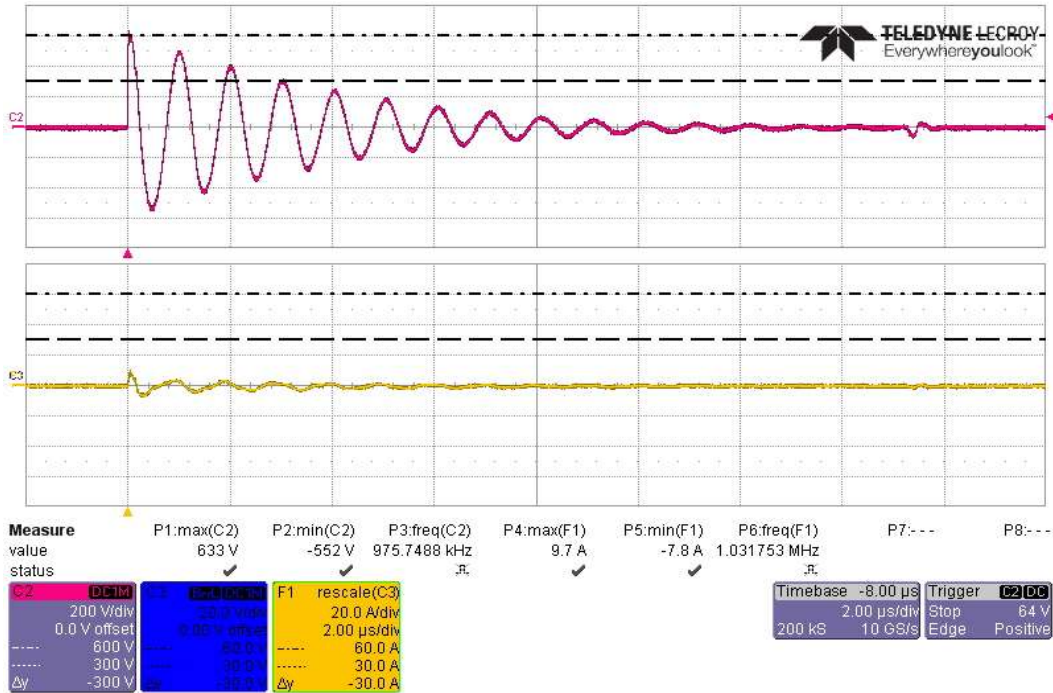

Actual Test CS117 Waveform #3 at 1MHz, First Transient +600V, on Battery Bundle

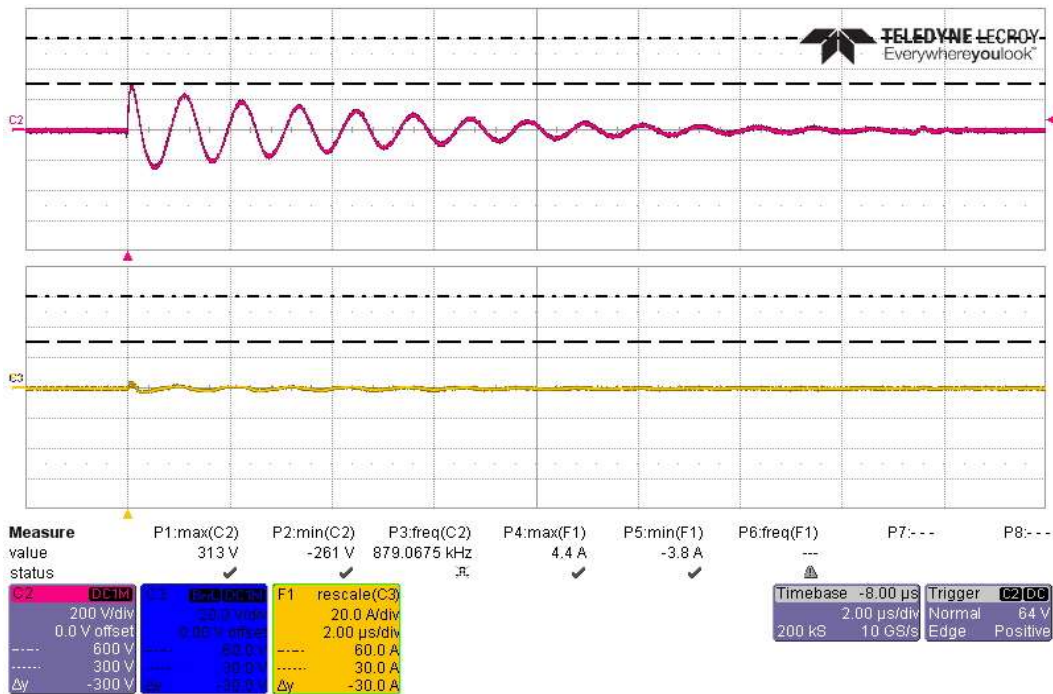

Actual Test CS117 Waveform #3 at 1MHz, Subsequent Transient +300V, on Battery Bundle

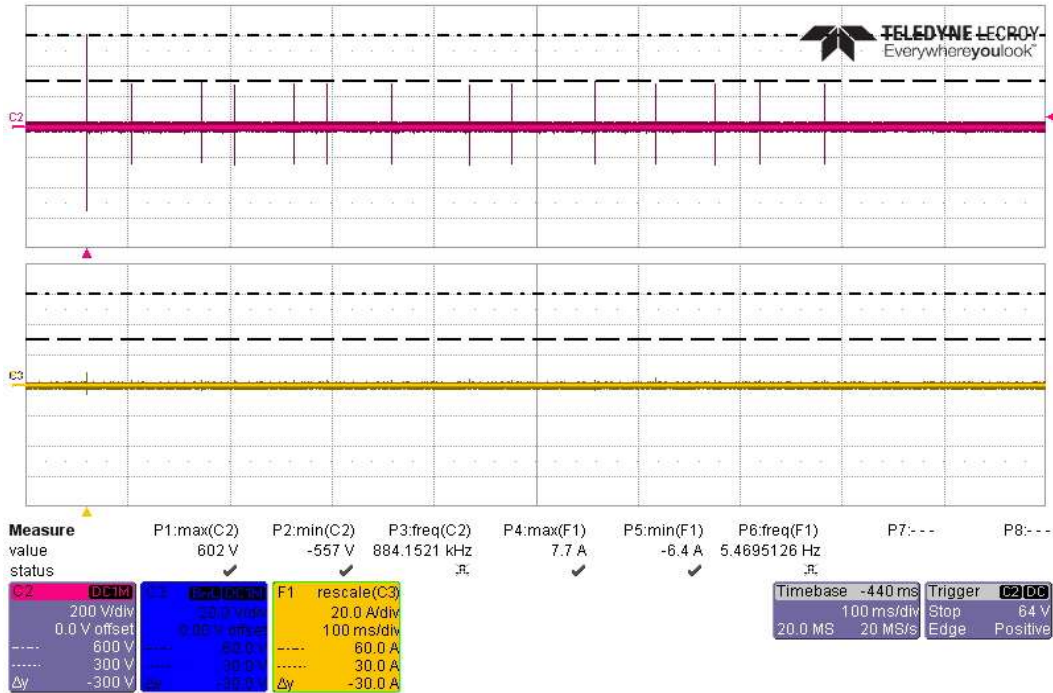

Actual Test CS117 Waveform #3 at 1MHz, 14 Transients +600/+300V, on Battery Bundle

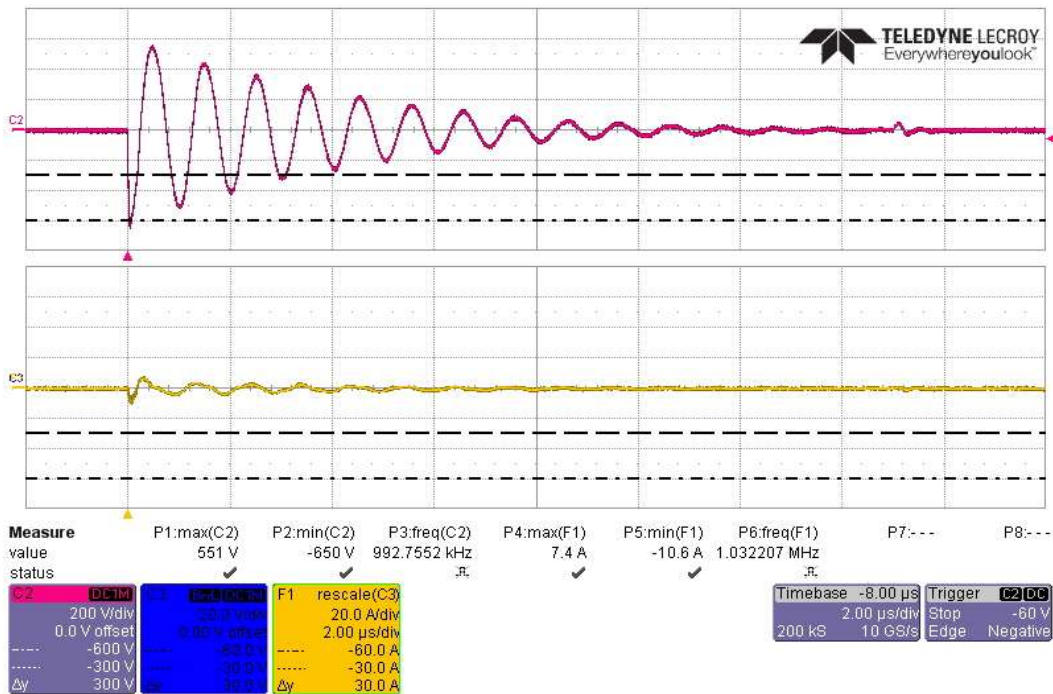

Actual Test CS117 Waveform #3 at 1MHz, First Transient -600V, on Battery Bundle

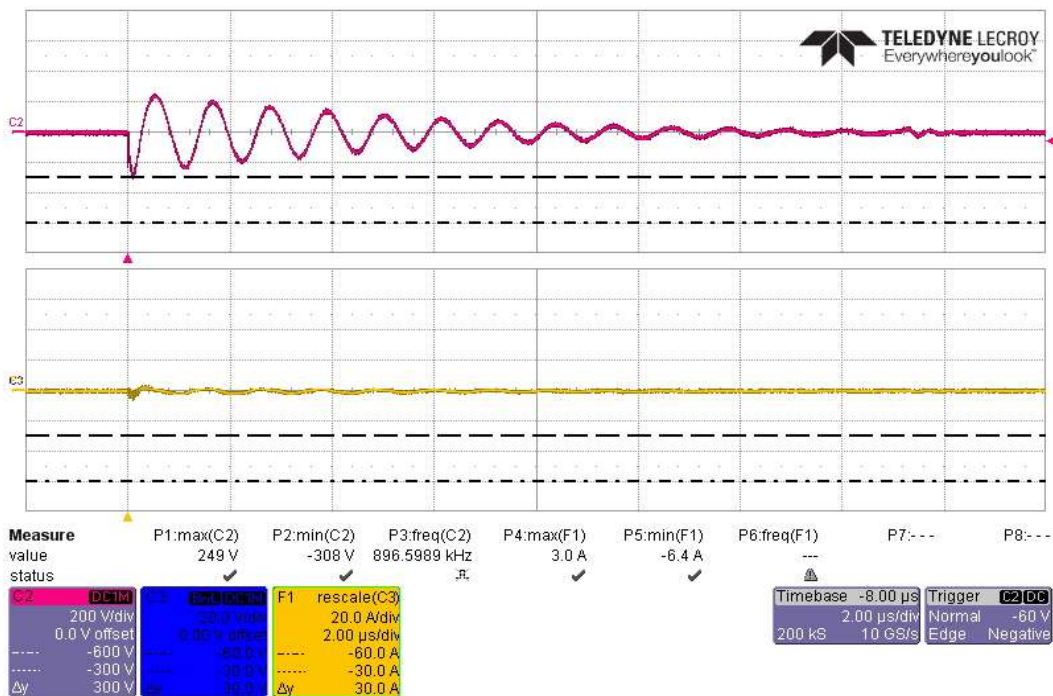

Actual Test CS117 Waveform #3 at 1MHz, Subsequent Transient -300V, on Battery Bundle

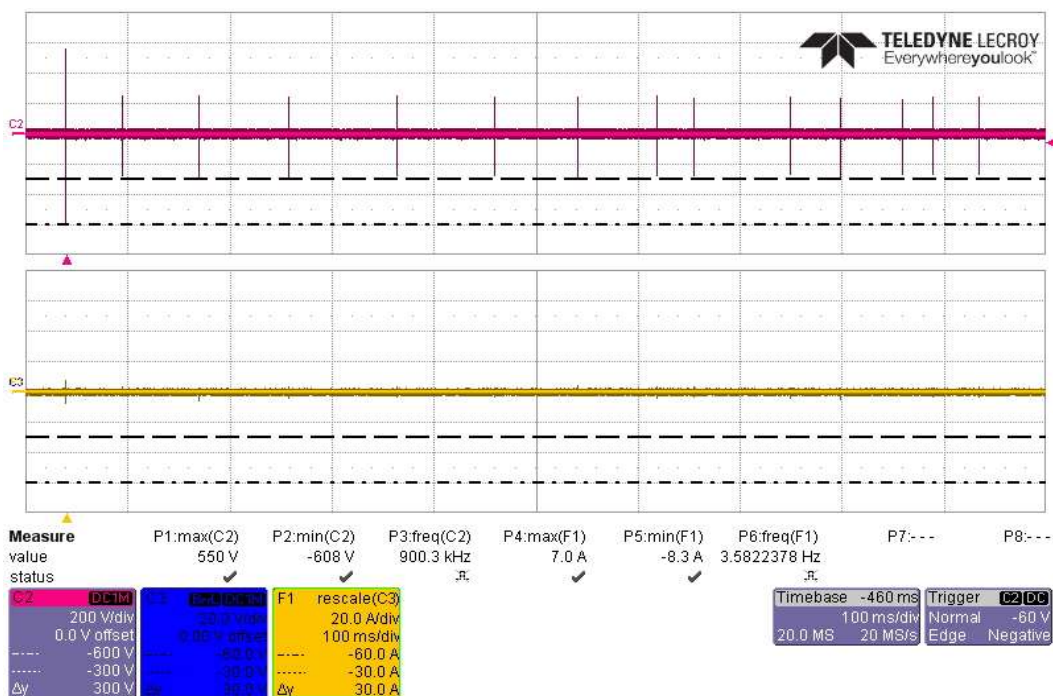

Actual Test CS117 Waveform #3 at 1MHz, 14 Transients -600/-300V, on Battery Bundle

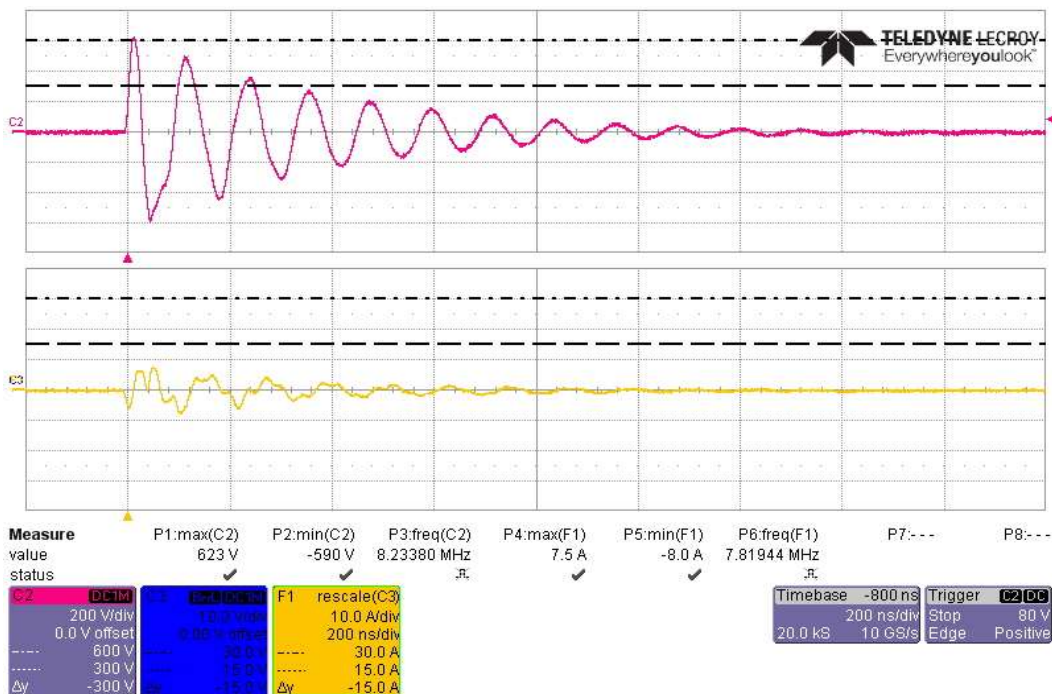
CS117 Actual MS Test Waveform #3 at 10MHz with 600V/24A

Actual Test CS117 Waveform #3 at 10MHz, First Transient +600V, on Battery High Side

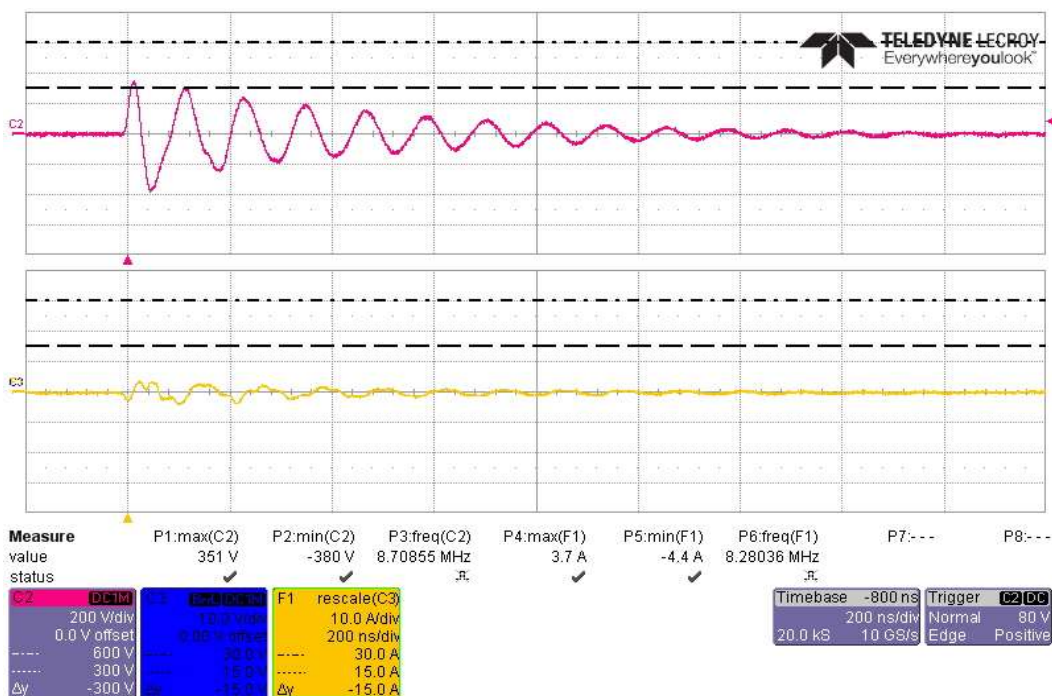

Actual Test CS117 Waveform #3 at 10MHz, Subsequent Transient +300V, on Battery High Side

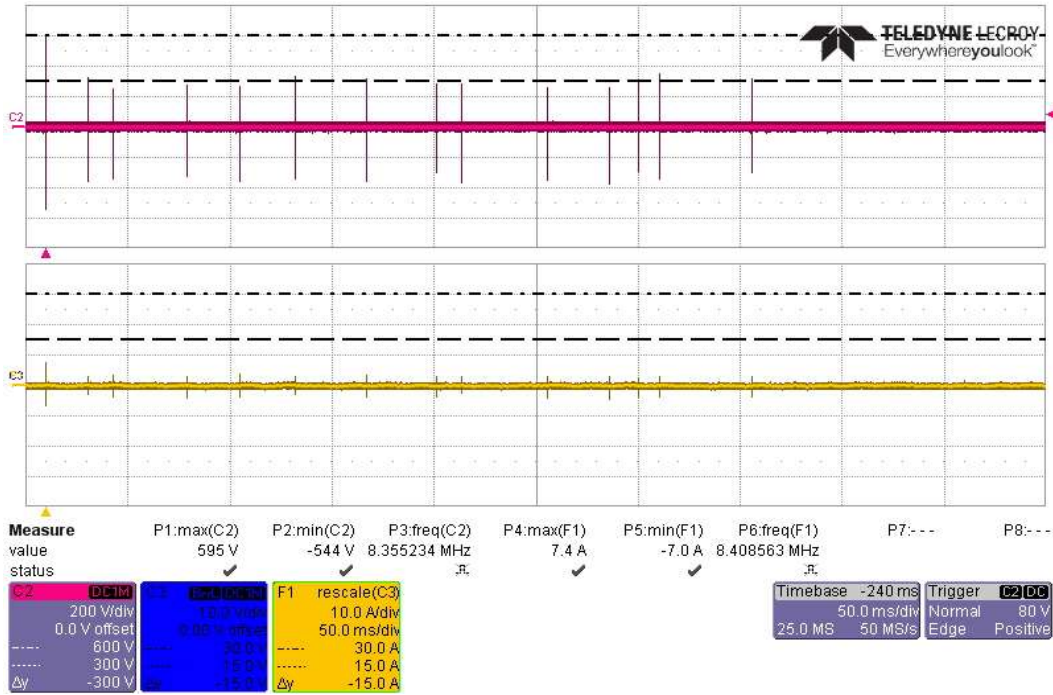

Actual Test CS117 Waveform #3 at 10MHz, 14 Transients +600/+300V, on Battery High Side

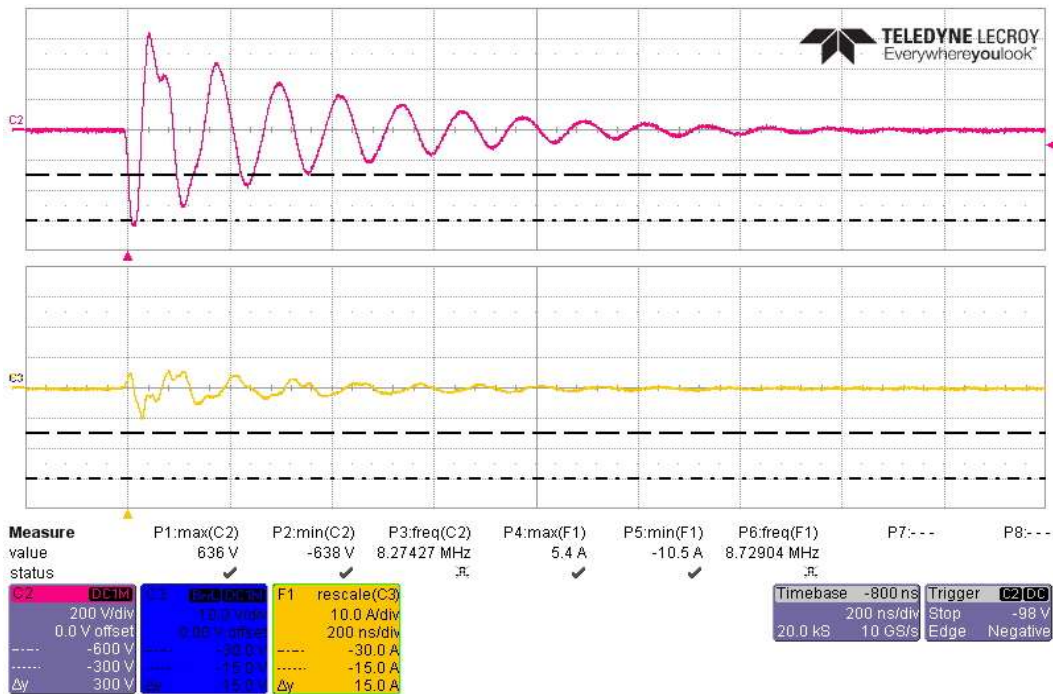

Actual Test CS117 Waveform #3 at 10MHz, First Transient -600V, on Battery High Side

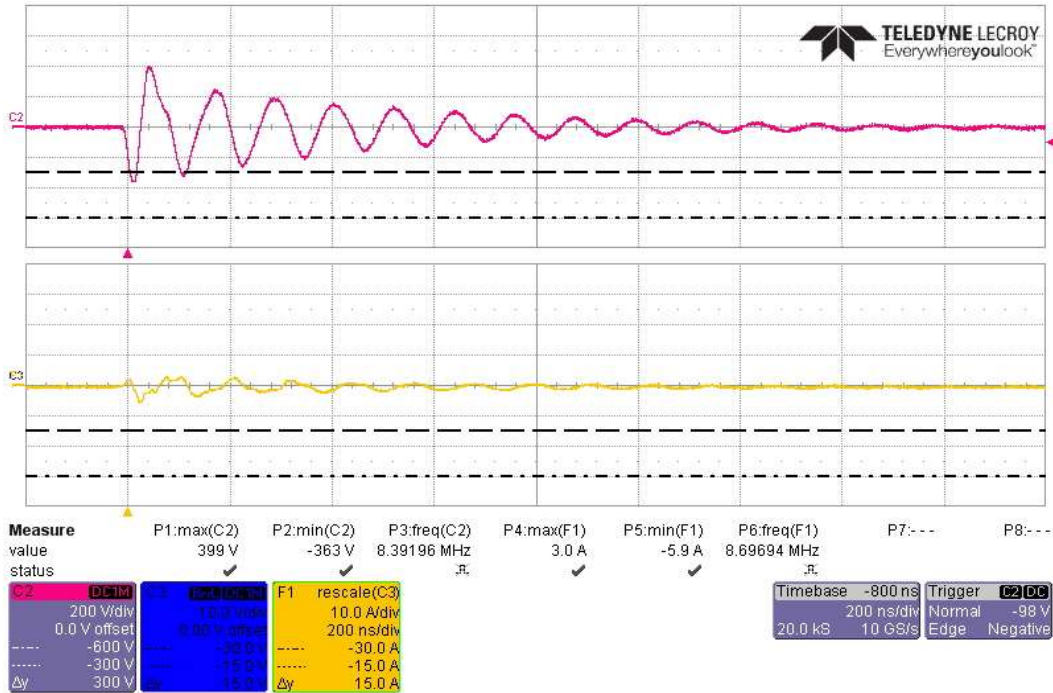

Actual Test CS117 Waveform #3 at 10MHz, Subsequent Transient -300V, on Battery High Side

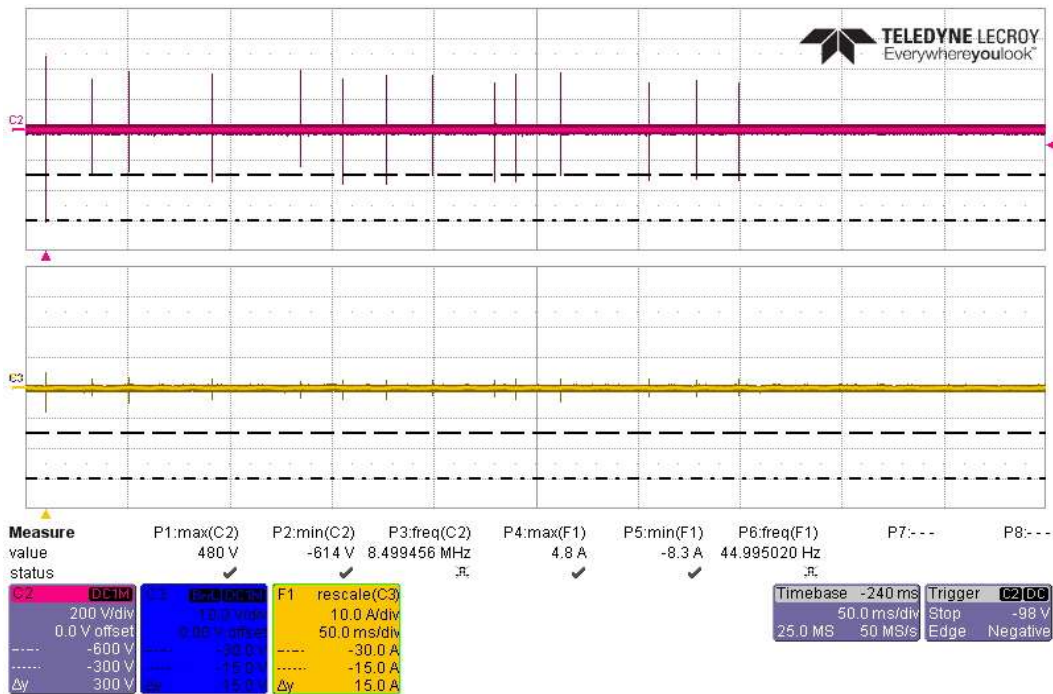

Actual Test CS117 Waveform #3 at 10MHz, 14 Transients -600/-300V, on Battery High Side

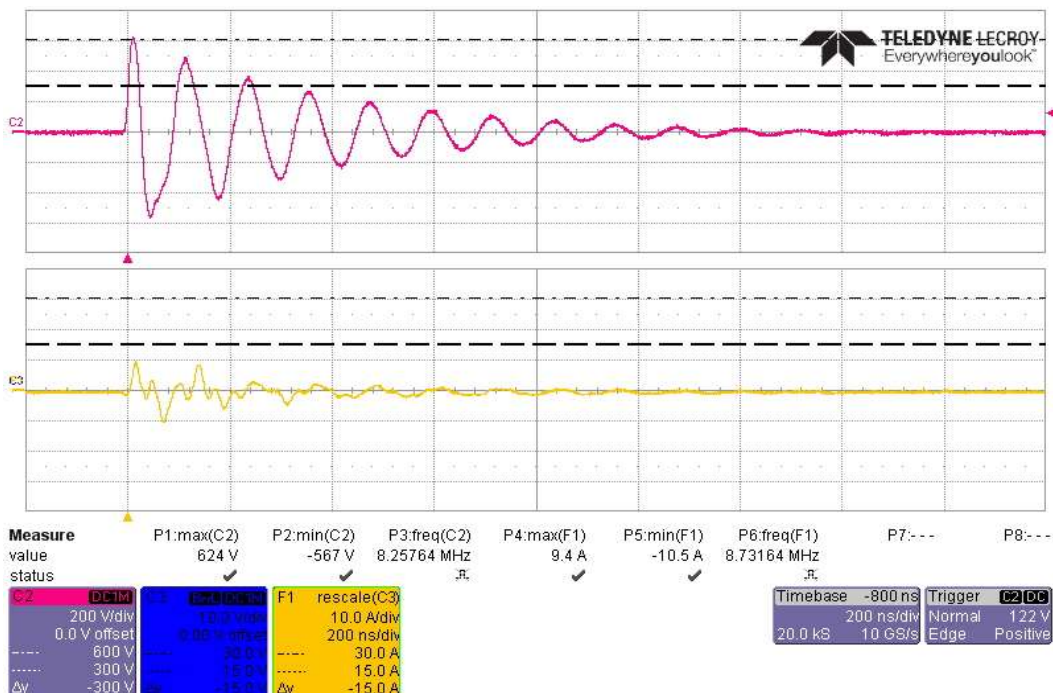

Actual Test CS117 Waveform #3 at 10MHz, First Transient +600V, on Battery Return Side

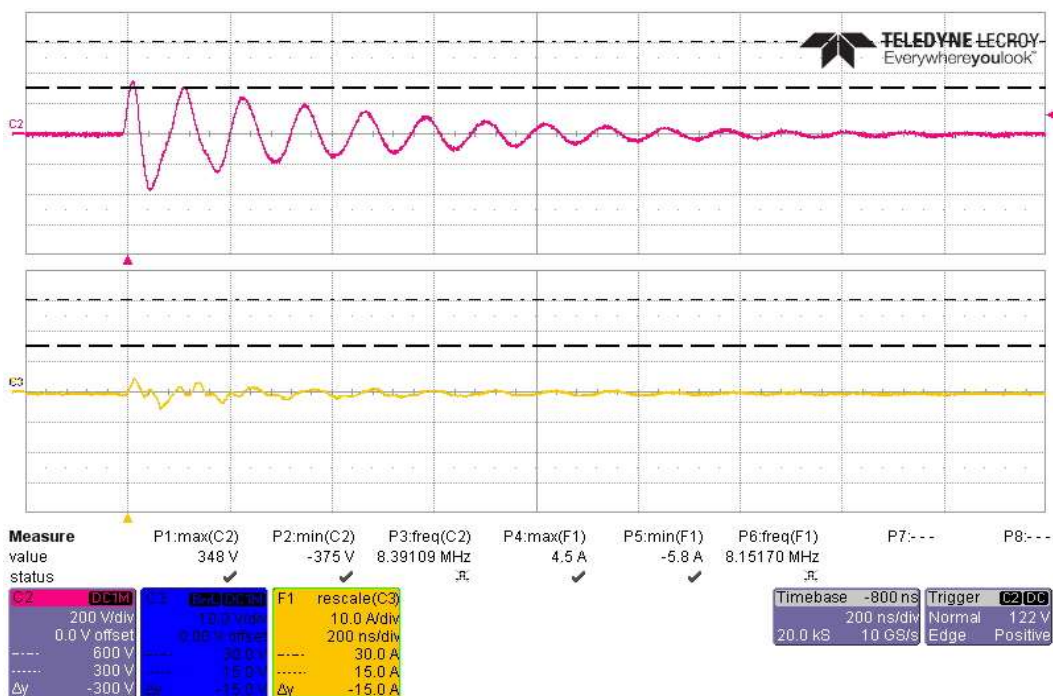

Actual Test CS117 Waveform #3 at 10MHz, Subsequent Transient +300V, on Battery Return Side

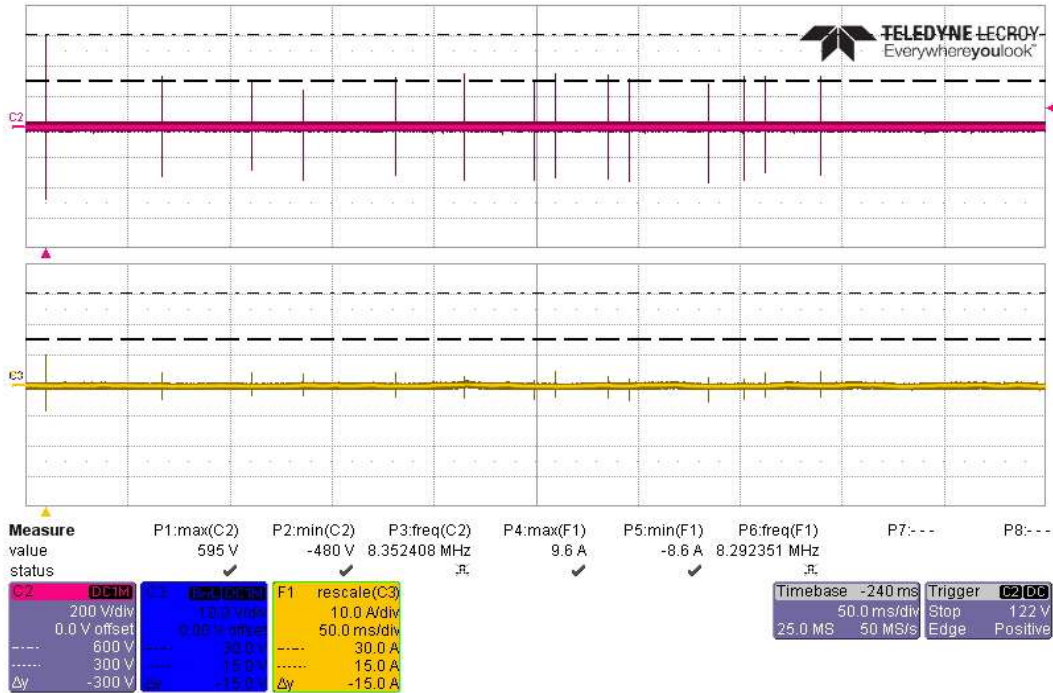

Actual Test CS117 Waveform #3 at 10MHz, 14 Transients +600/+300V, on Battery Return Side

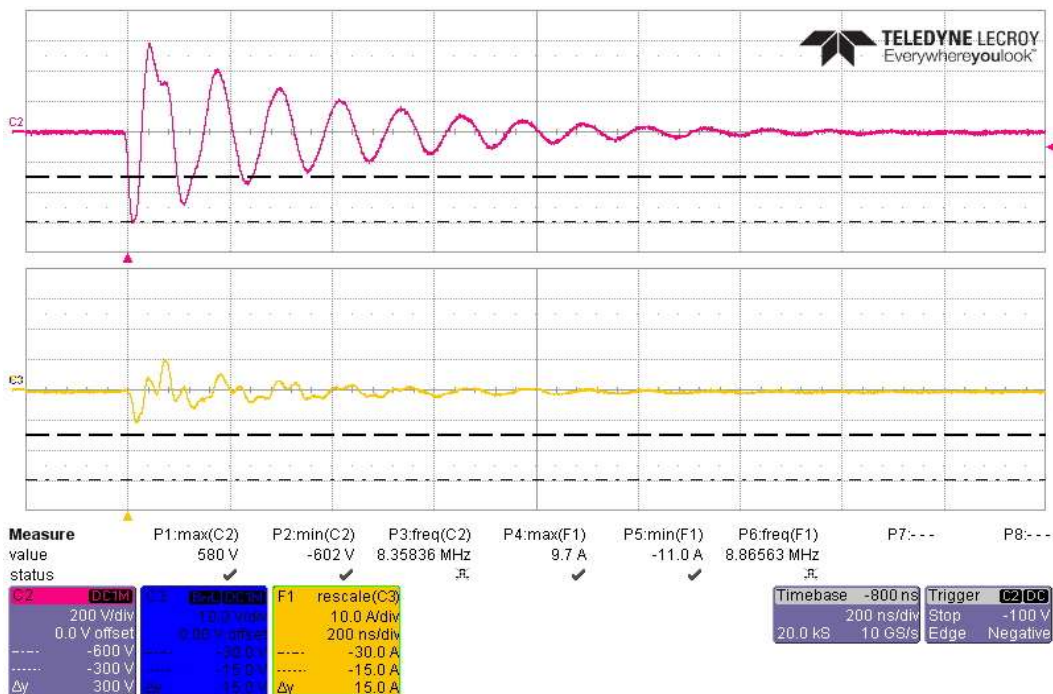

Actual Test CS117 Waveform #3 at 10MHz, First Transient -600V, on Battery Return Side

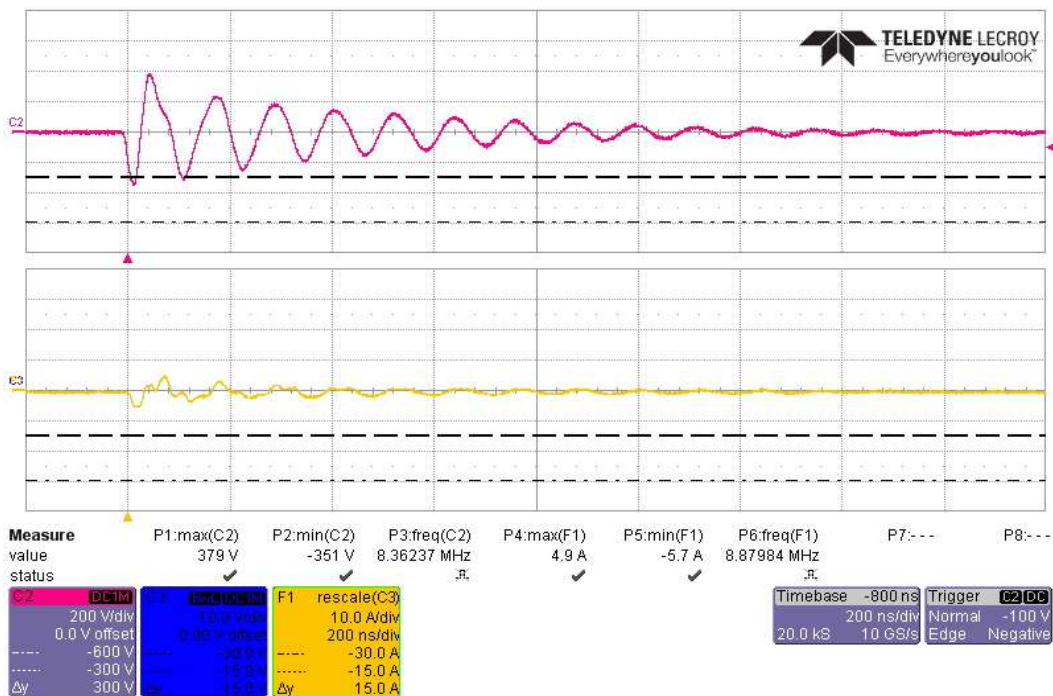

Actual Test CS117 Waveform #3 at 10MHz, Subsequent Transient -300V, on Battery Return Side

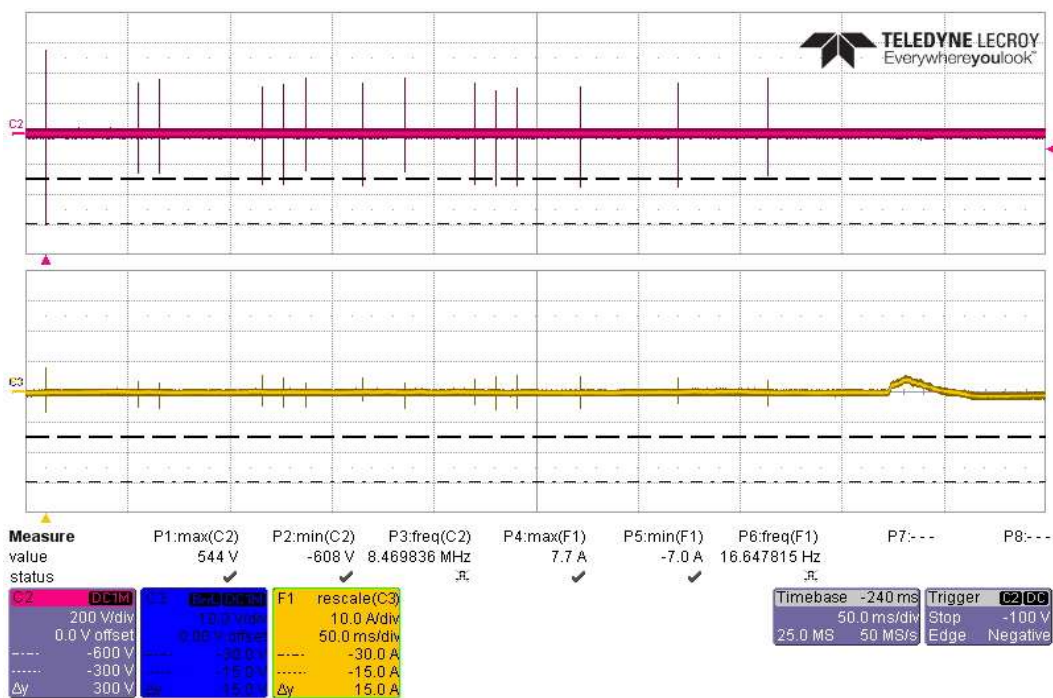

Actual Test CS117 Waveform #3 at 10MHz, 14 Transients -600/300V, on Battery Return Side

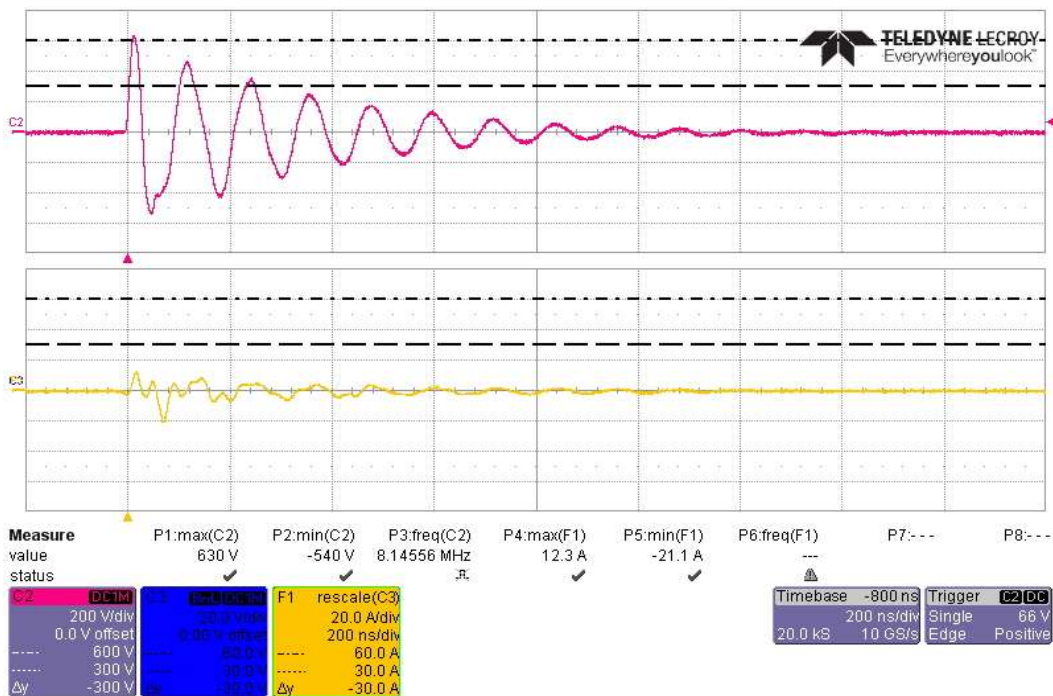

Actual Test CS117 Waveform #3 at 10MHz, First Transient +600V, on Battery Bundle

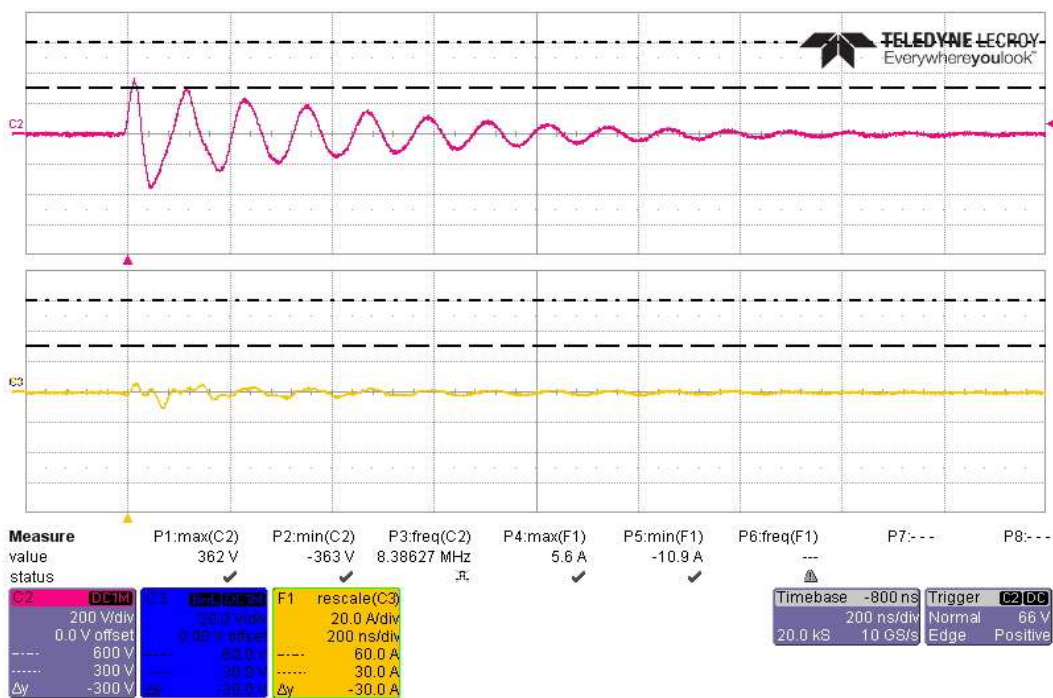

Actual Test CS117 Waveform #3 at 10MHz, Subsequent Transient +300V, on Battery Bundle

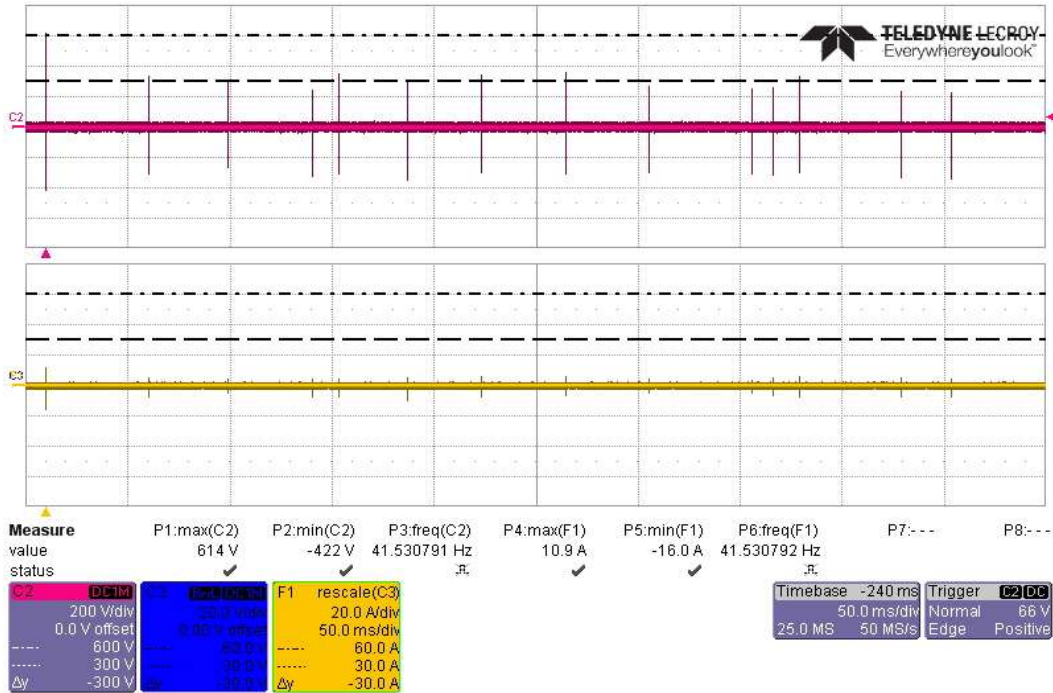

Actual Test CS117 Waveform #3 at 10MHz, 14 Transients +600/+300V, on Battery Bundle

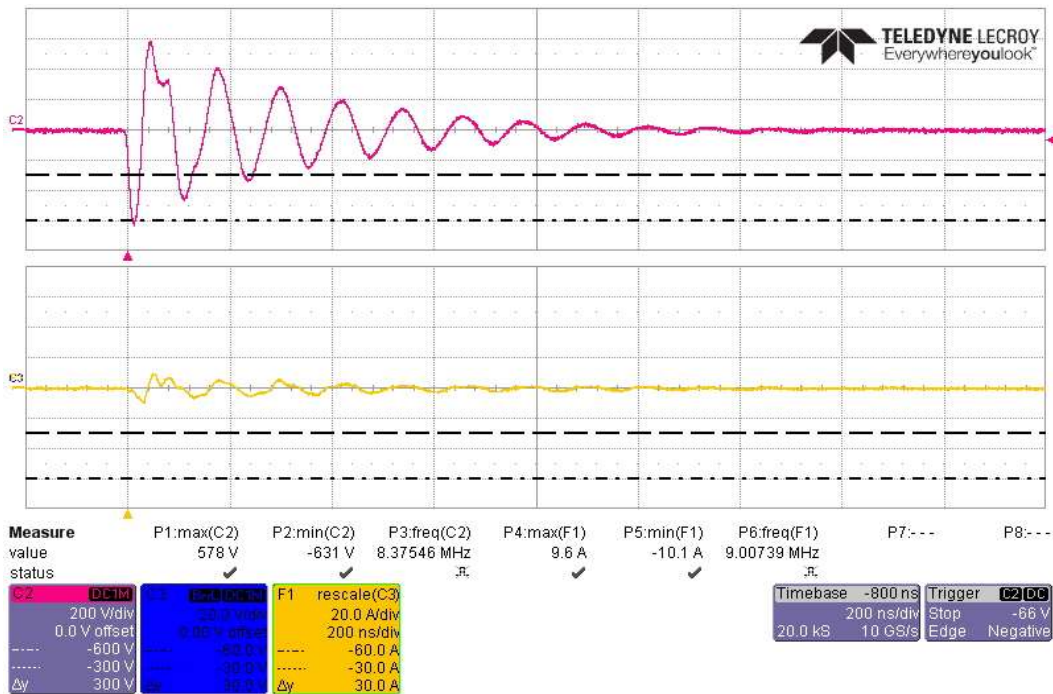

Actual Test CS117 Waveform #3 at 10MHz, First Transient -600V, on Battery Bundle

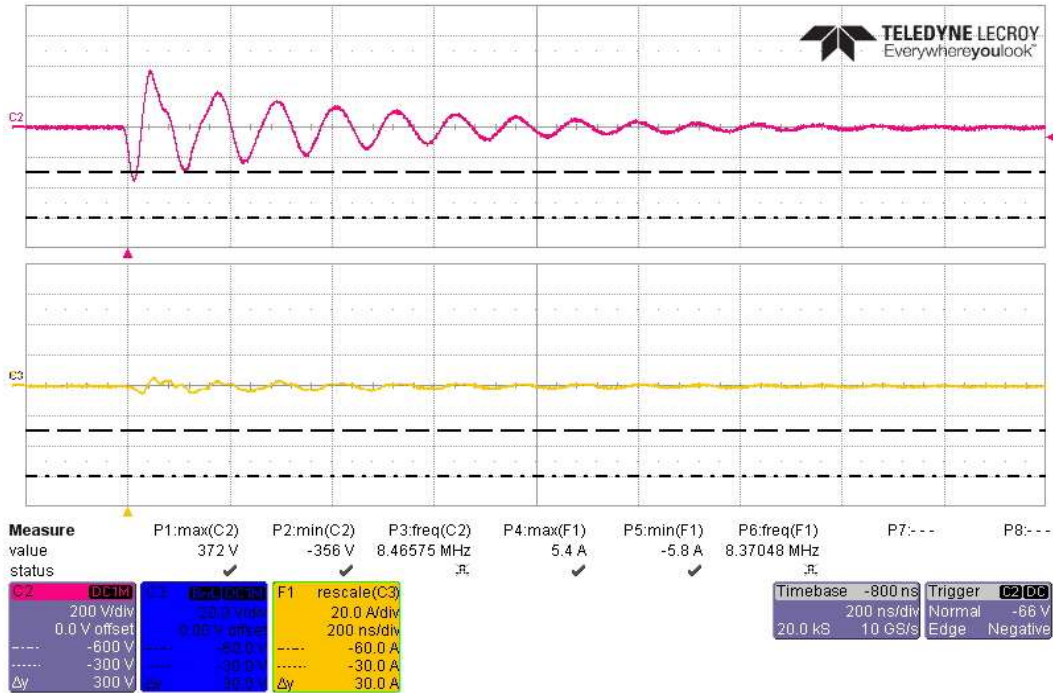

Actual Test CS117 Waveform #3 at 10MHz, Subsequent Transient -300V, on Battery Bundle

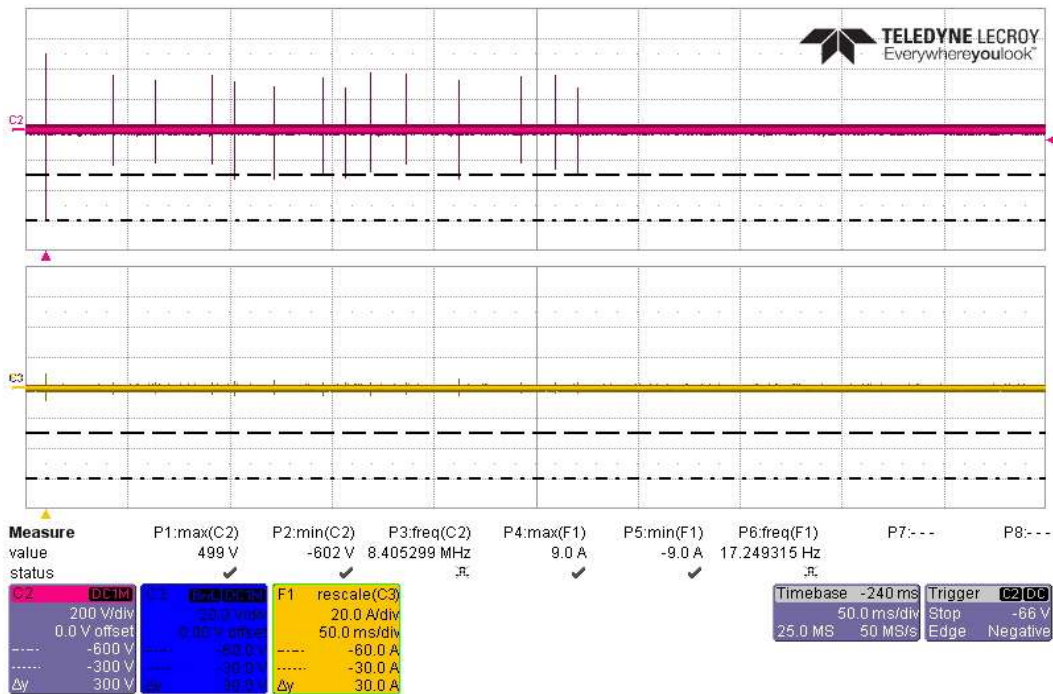

Actual Test CS117 Waveform #3 at 10MHz, 14 Transients -600/-300V, on Battery Bundle

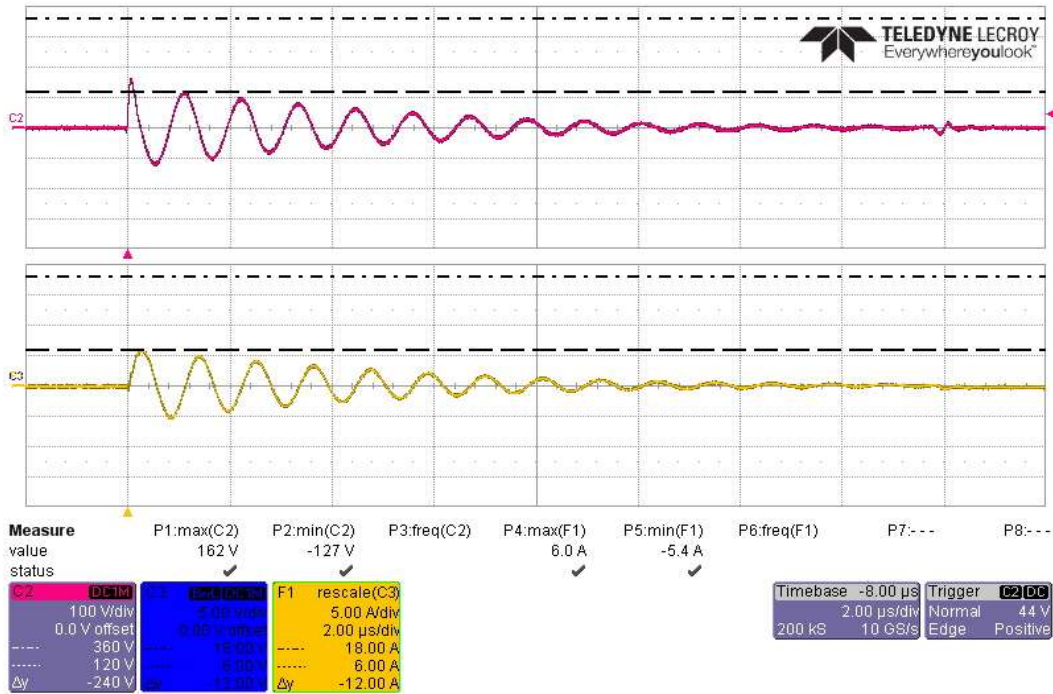
CS117 Actual Test Multiple Burst Waveform #3 at 1MHz with 360V/6A

Actual Test CS117 Waveform #3 at 1MHz, First Transient +360V/6A, on Battery High Side

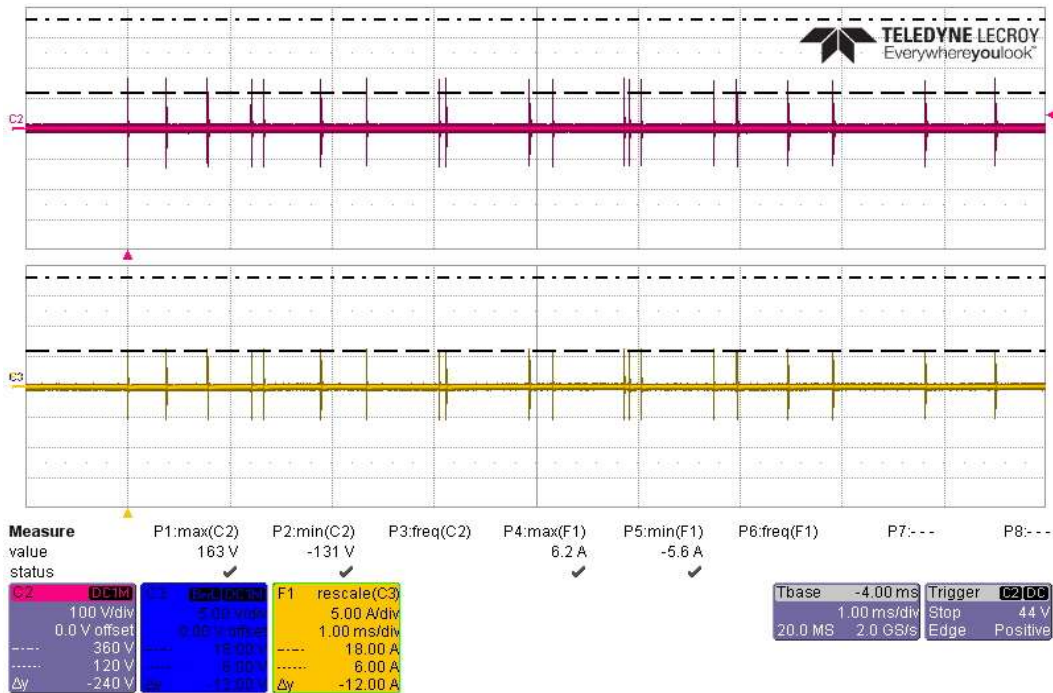

Actual Test CS117 Waveform #3 at 1MHz, 20 Transients +360V/6A, on Battery High Side

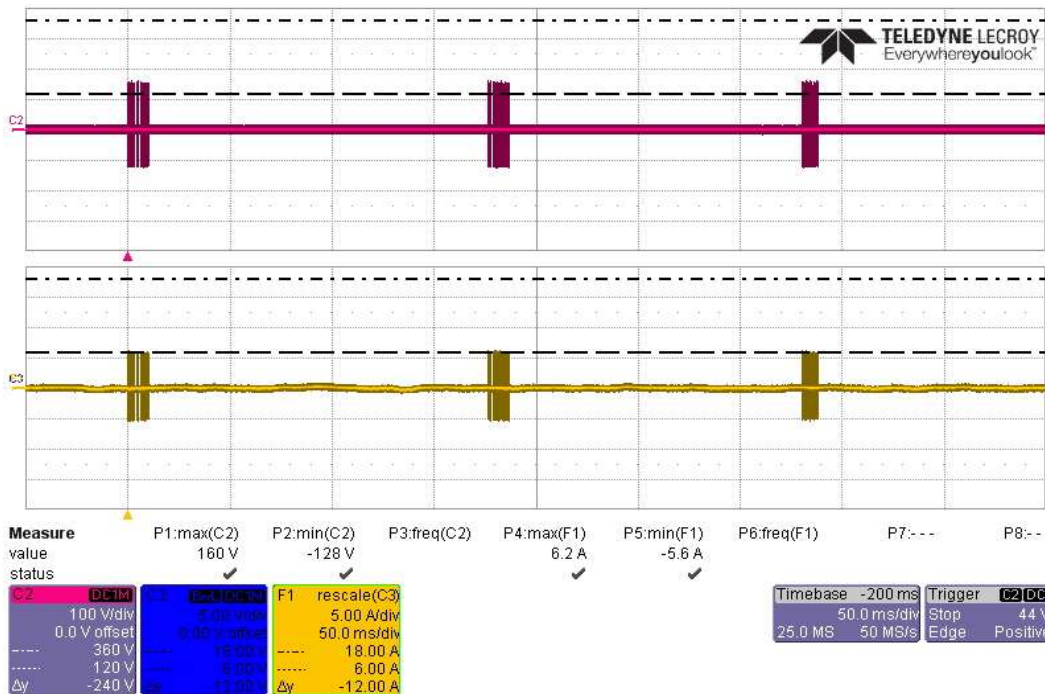

Actual Test CS117 Waveform #3 at 1MHz, 3 Bursts +360V/6A, on Battery High Side

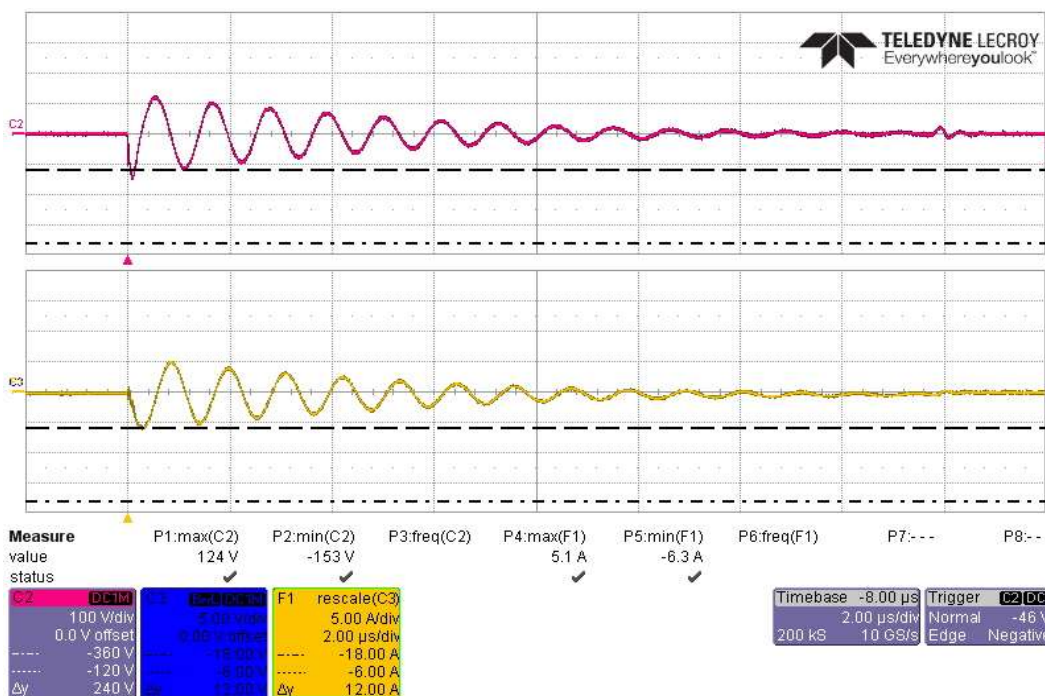

Actual Test CS117 Waveform #3 at 1MHz, First Transient -360V/6A, on Battery High Side

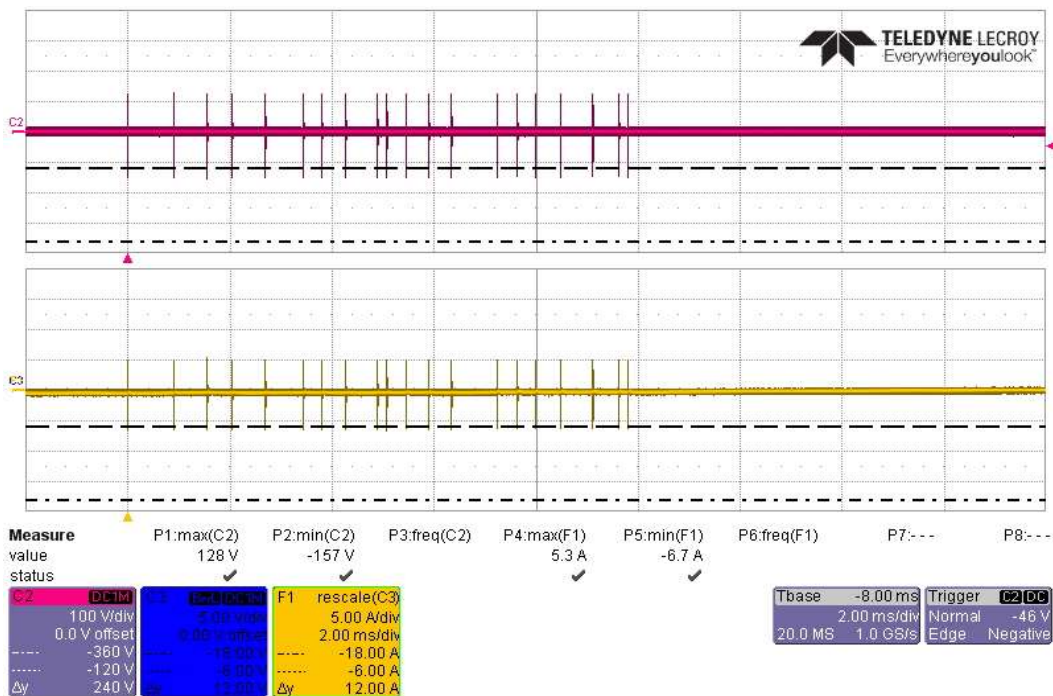

Actual Test CS117 Waveform #3 at 1MHz, 20 Transients -360V/6A, on Battery High Side

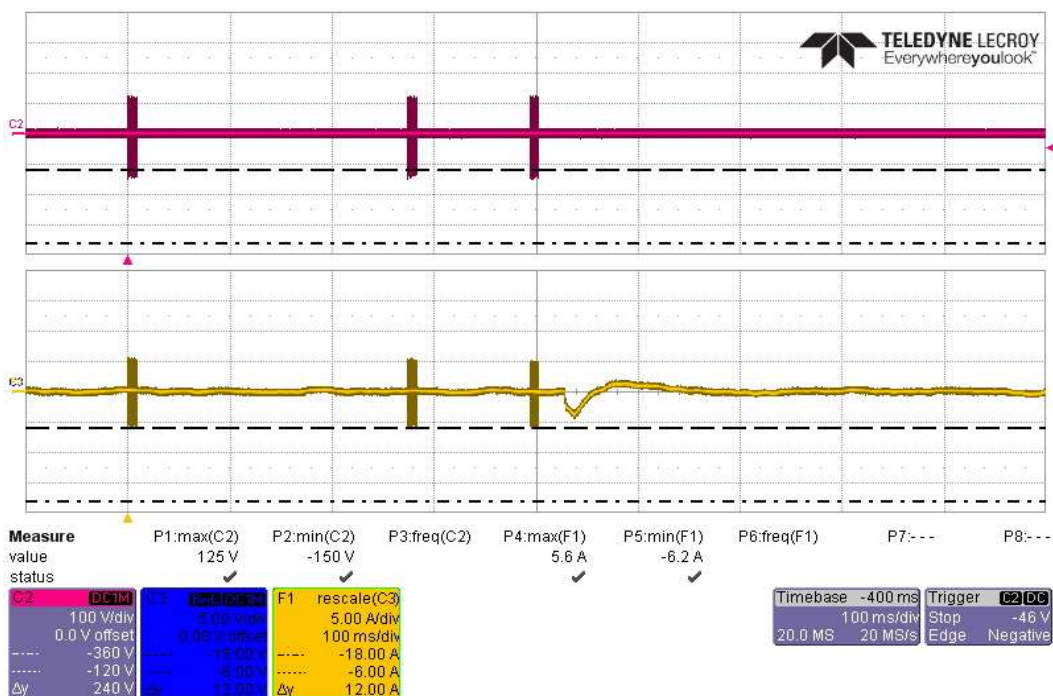

Actual Test CS117 Waveform #3 at 1MHz, 3 Bursts -360V/6A, on Battery High Side

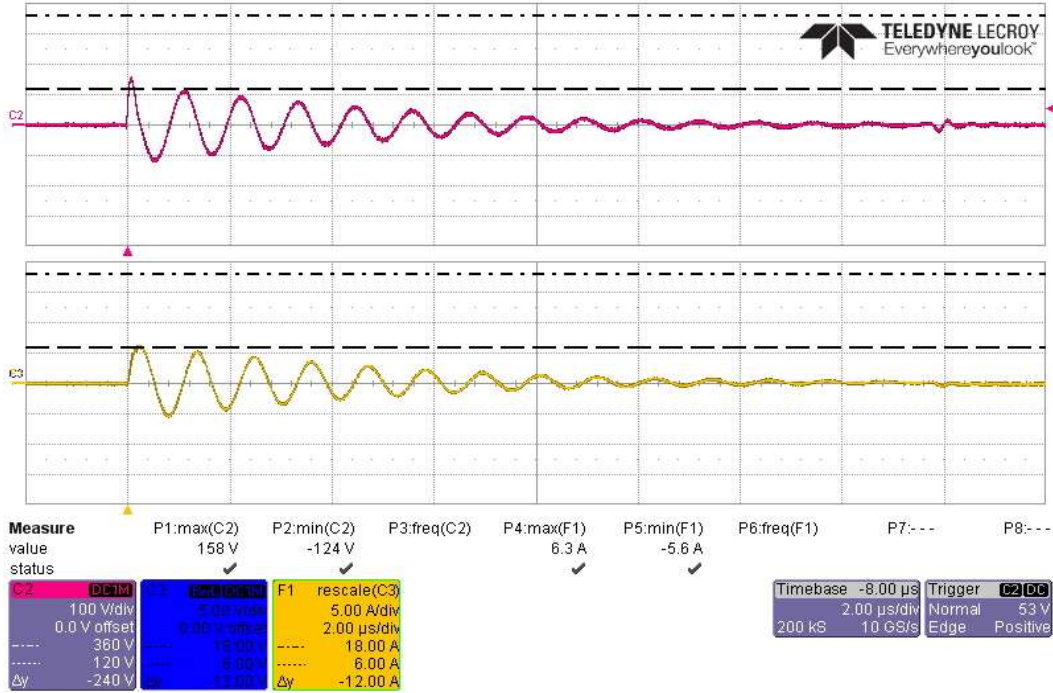

Actual Test CS117 Waveform #3 at 1MHz, First Transient +360V/6A, on Battery Return Side

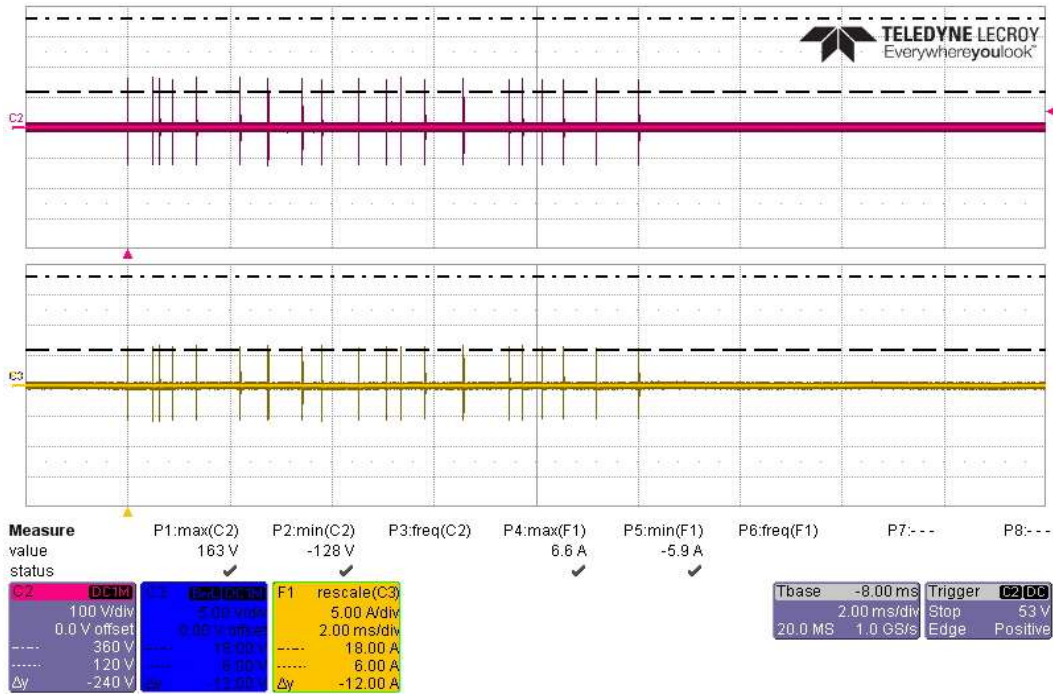

Actual Test CS117 Waveform #3 at 1MHz, 20 Transients +360V/6A, on Battery Return Side

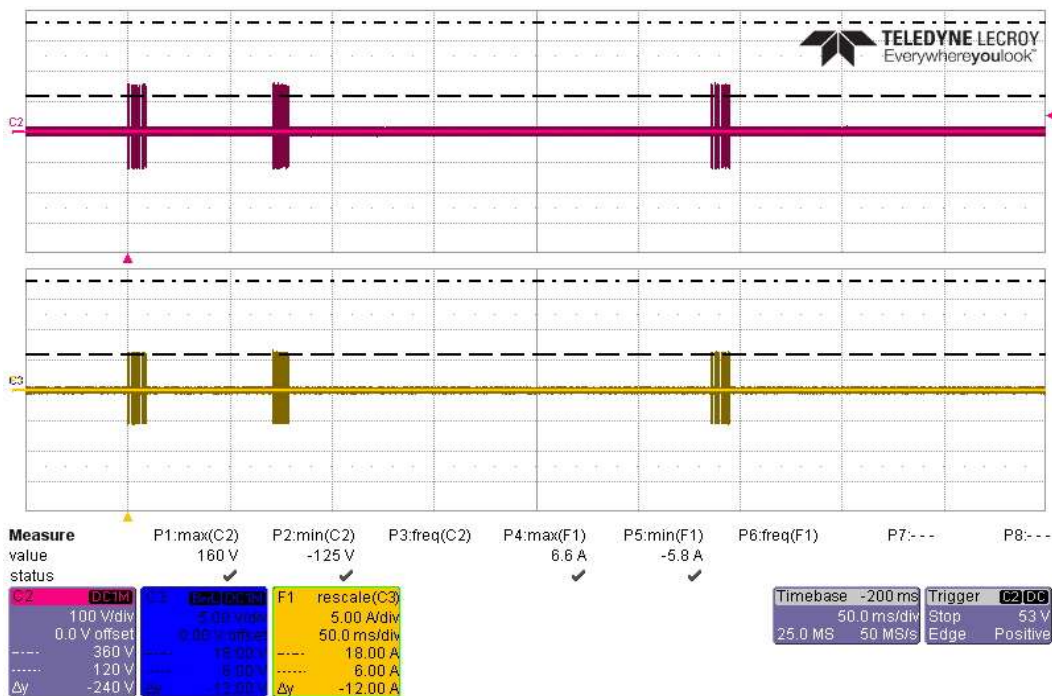

Actual Test CS117 Waveform #3 at 1MHz, 3 Bursts +360V/6A, on Battery Return Side

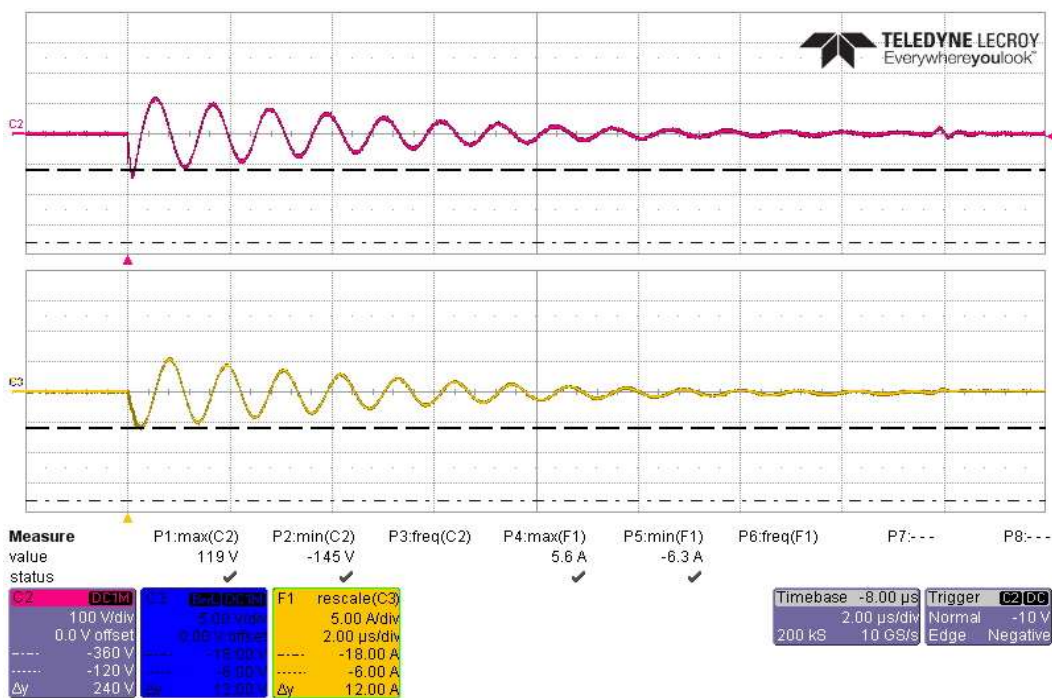

Actual Test CS117 Waveform #3 at 1MHz, First Transient -360V/6A, on Battery Return Side

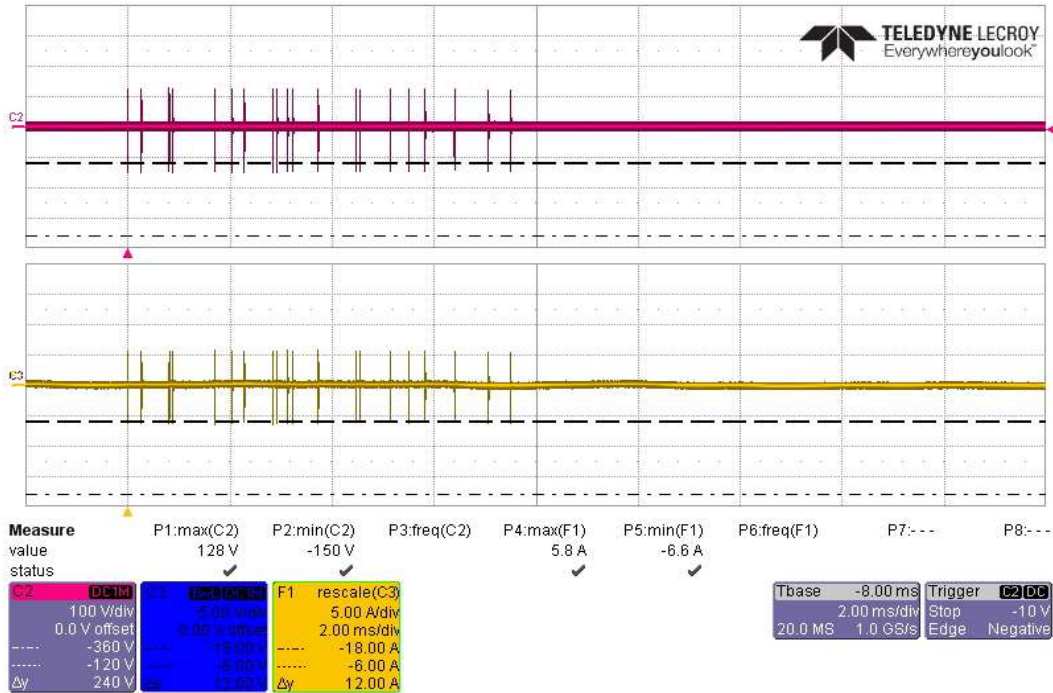

Actual Test CS117 Waveform #3 at 1MHz, 20 Transients -360V/6A, on Battery Return Side

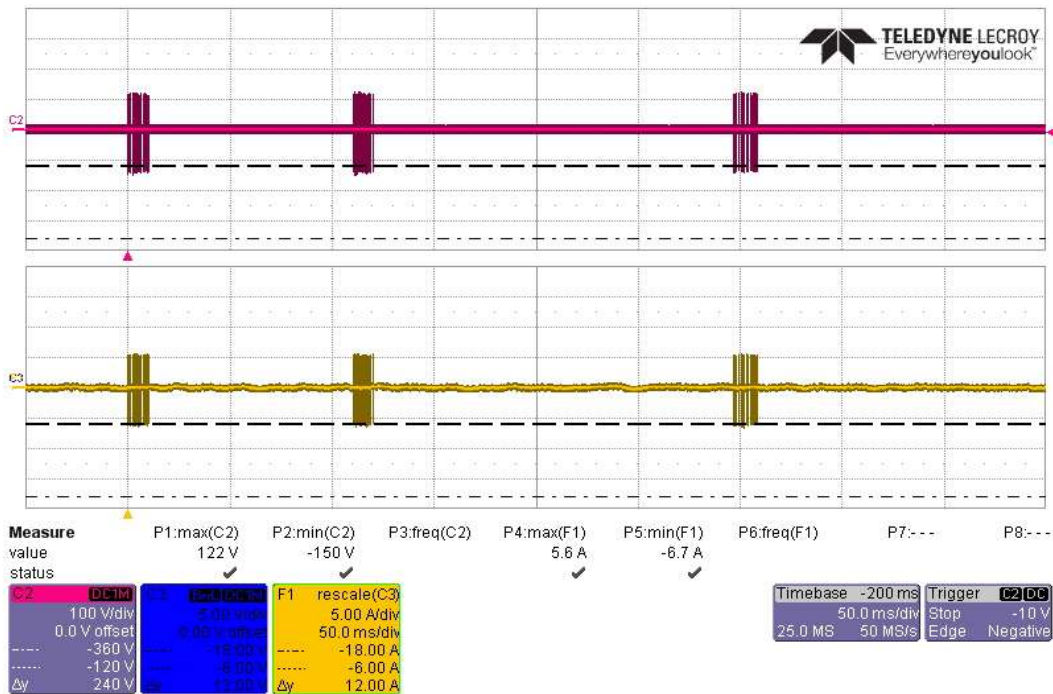

Actual Test CS117 Waveform #3 at 1MHz, 3 Bursts -360V/6A, on Battery Return Side

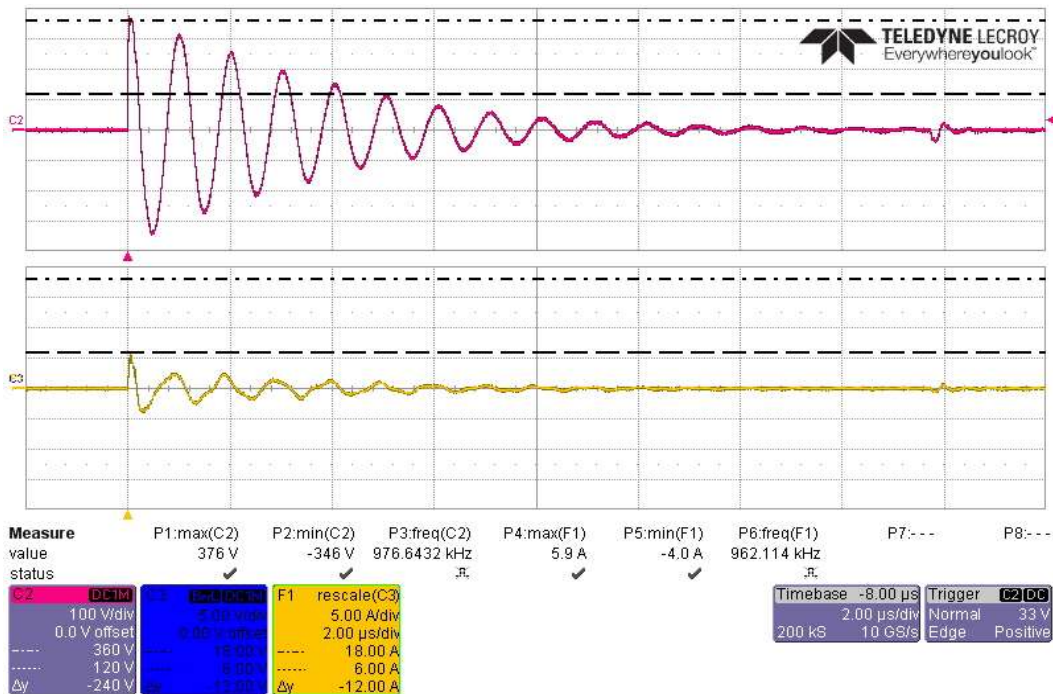

Actual Test CS117 Waveform #3 at 1MHz, First Transient +360V/6A, on Battery Bundle

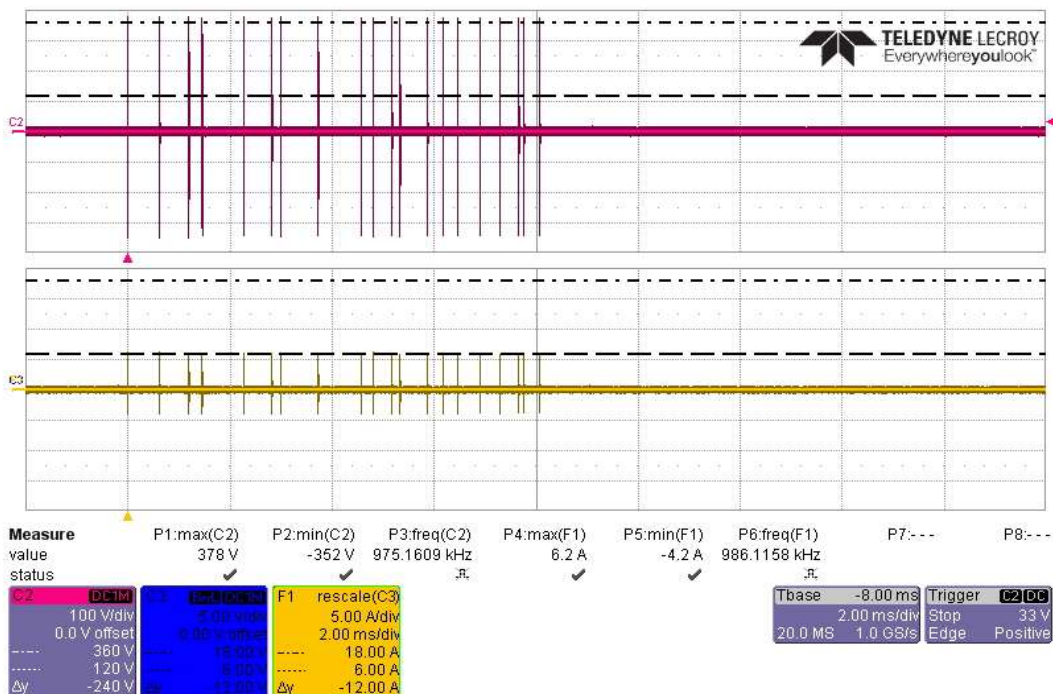

Actual Test CS117 Waveform #3 at 1MHz, 20 Transients +360V/6A, on Battery Bundle

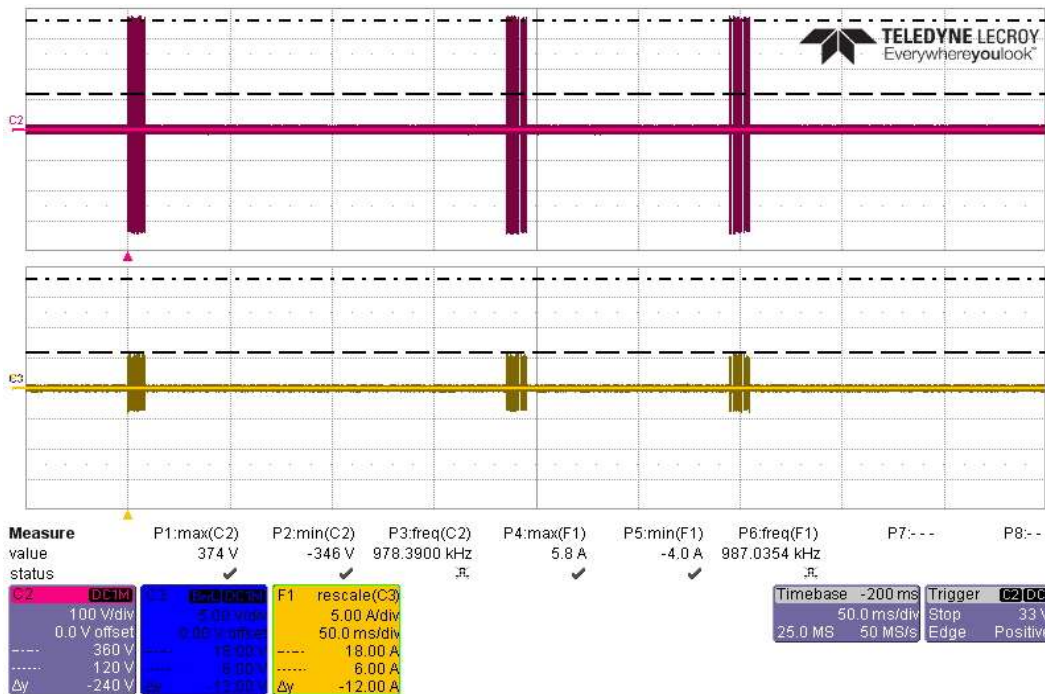

Actual Test CS117 Waveform #3 at 1MHz, 3 Bursts +360V/6A, on Battery Bundle

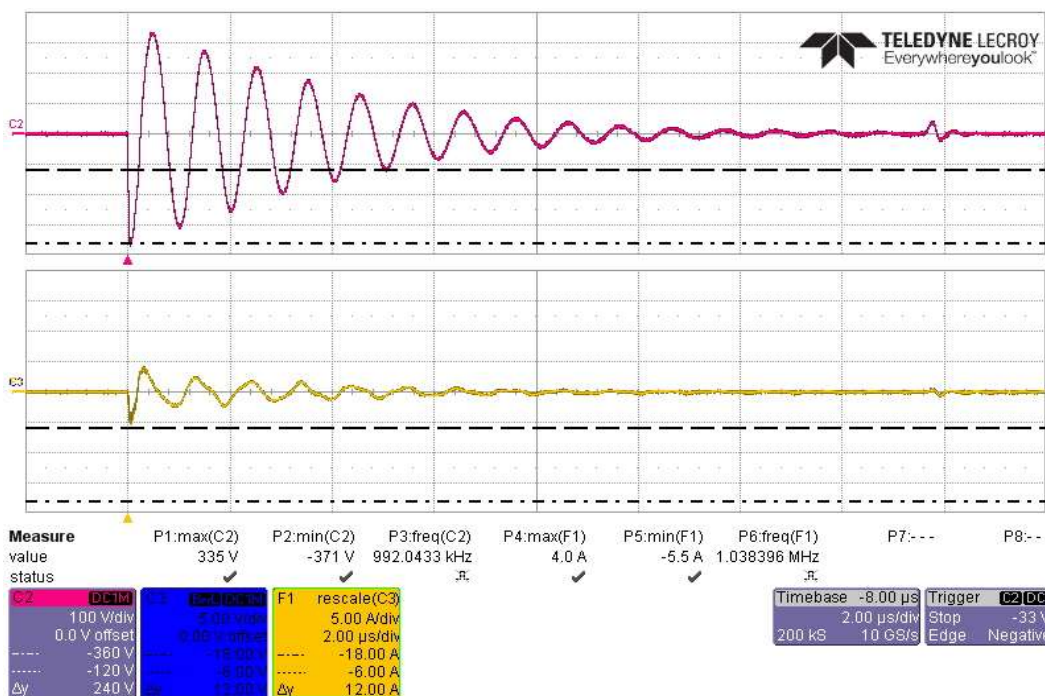

Actual Test CS117 Waveform #3 at 1MHz, First Transient -360V/6A, on Battery Bundle

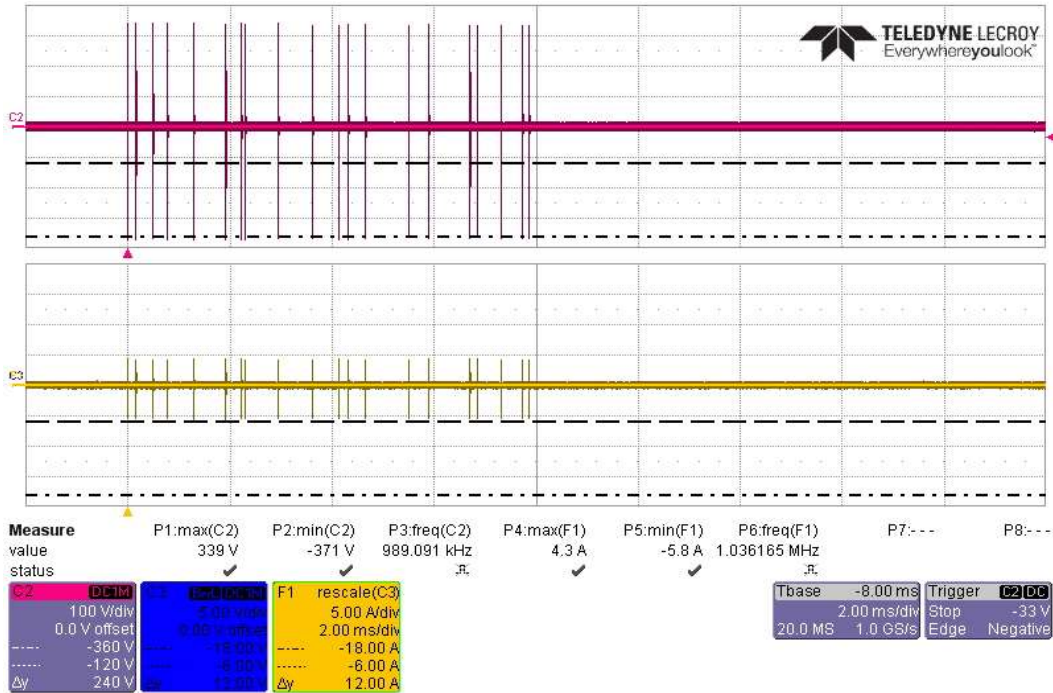

Actual Test CS117 Waveform #3 at 1MHz, 20 Transients -360V/6A, on Battery Bundle

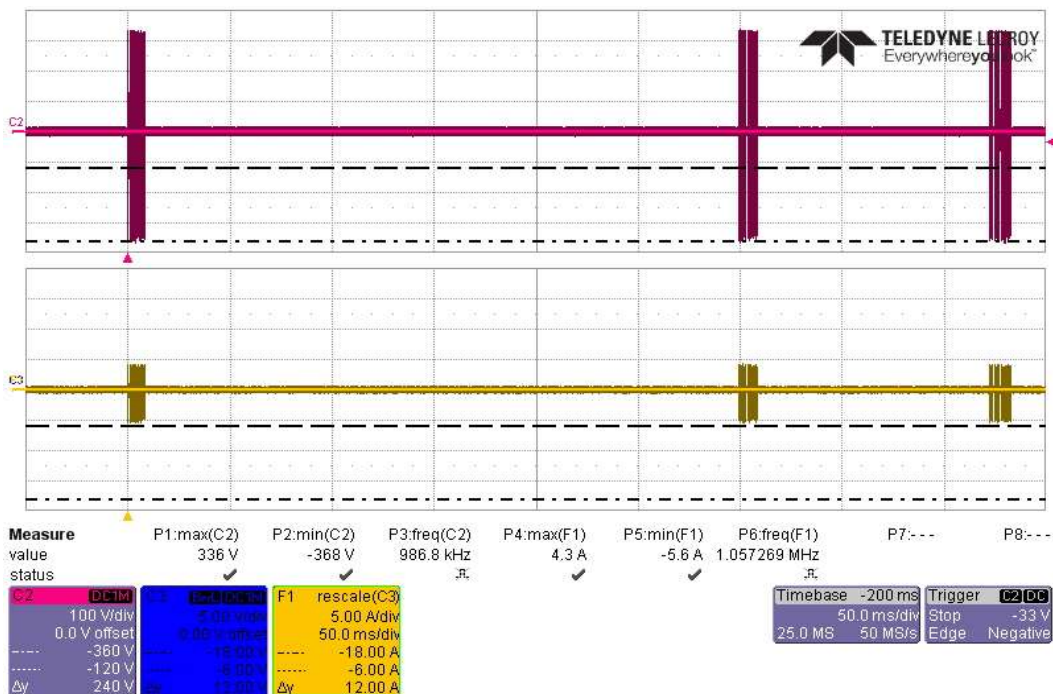

Actual Test CS117 Waveform #3 at 1MHz, 3 Bursts -360V/6A, on Battery Bundle

CS117 Actual Test Multiple Burst Waveform #3 at 10MHz with 360V/6A

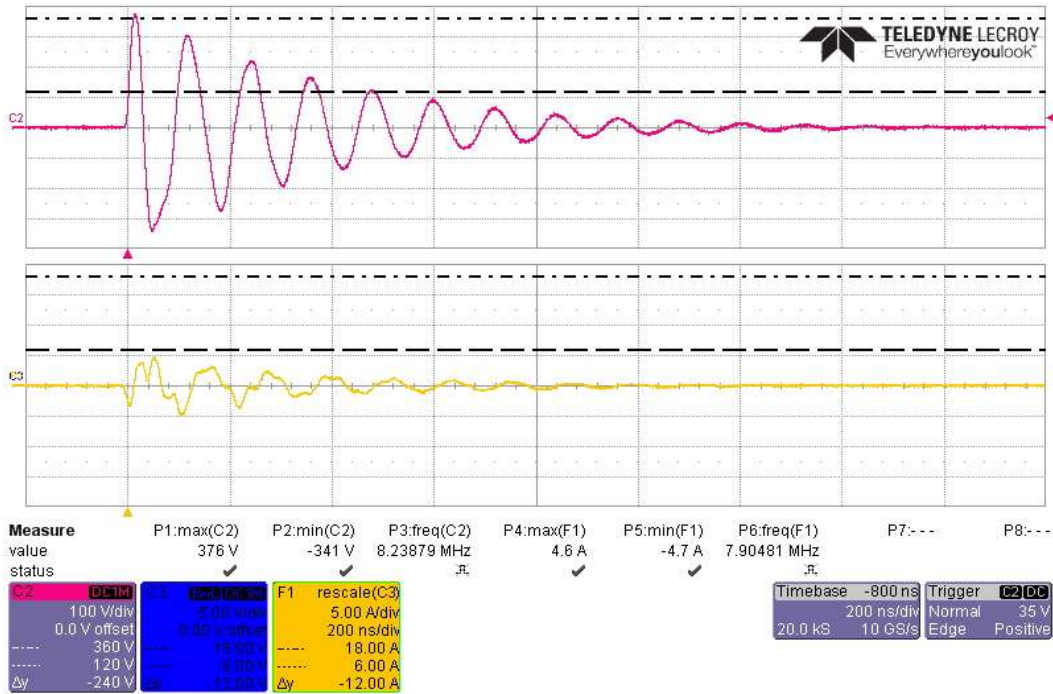

Actual Test CS117 Waveform #3 at 10MHz, First Transient +360V/6A, on Battery High Side

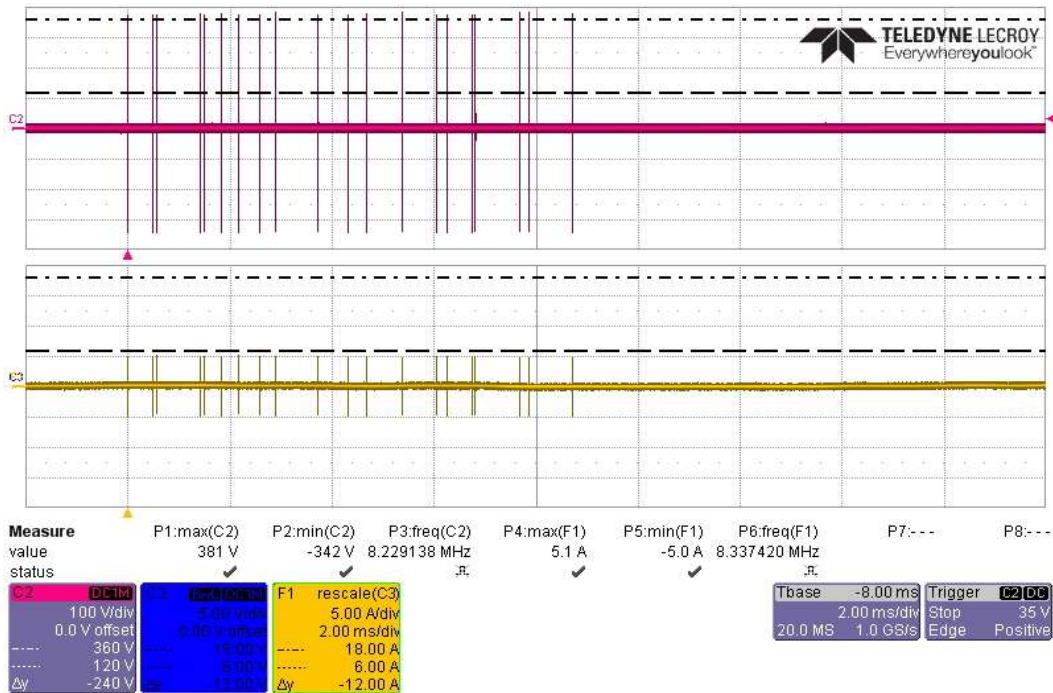

Actual Test CS117 Waveform #3 at 10MHz, 20 Transients +360V/6A, on Battery High Side

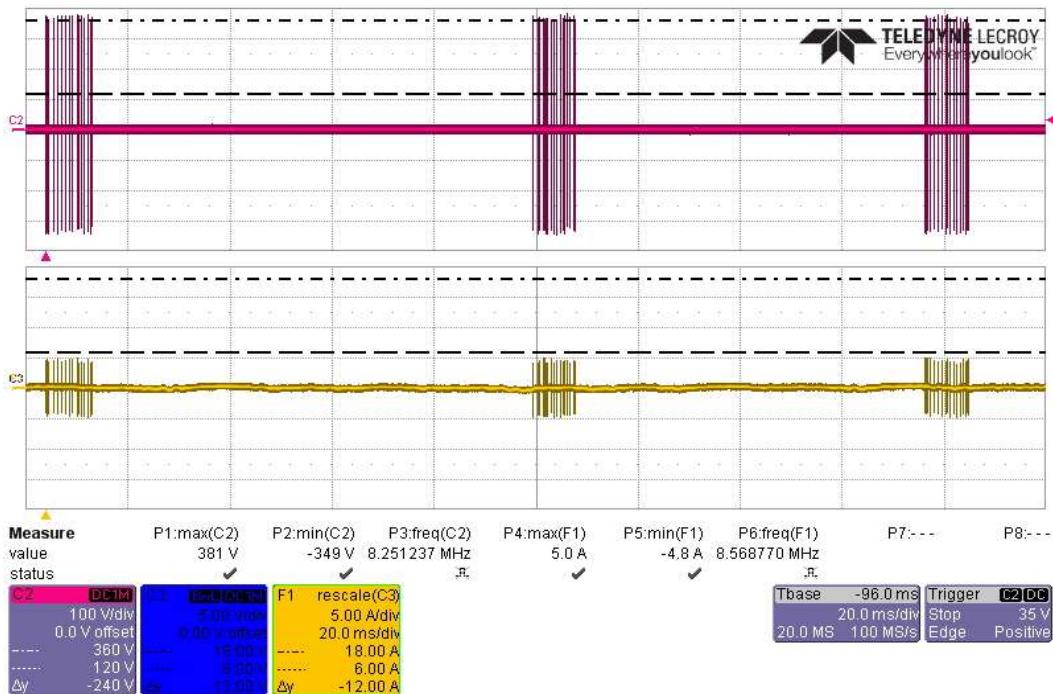

Actual Test CS117 Waveform #3 at 10MHz, 3 Bursts +360V/6A, on Battery High Side

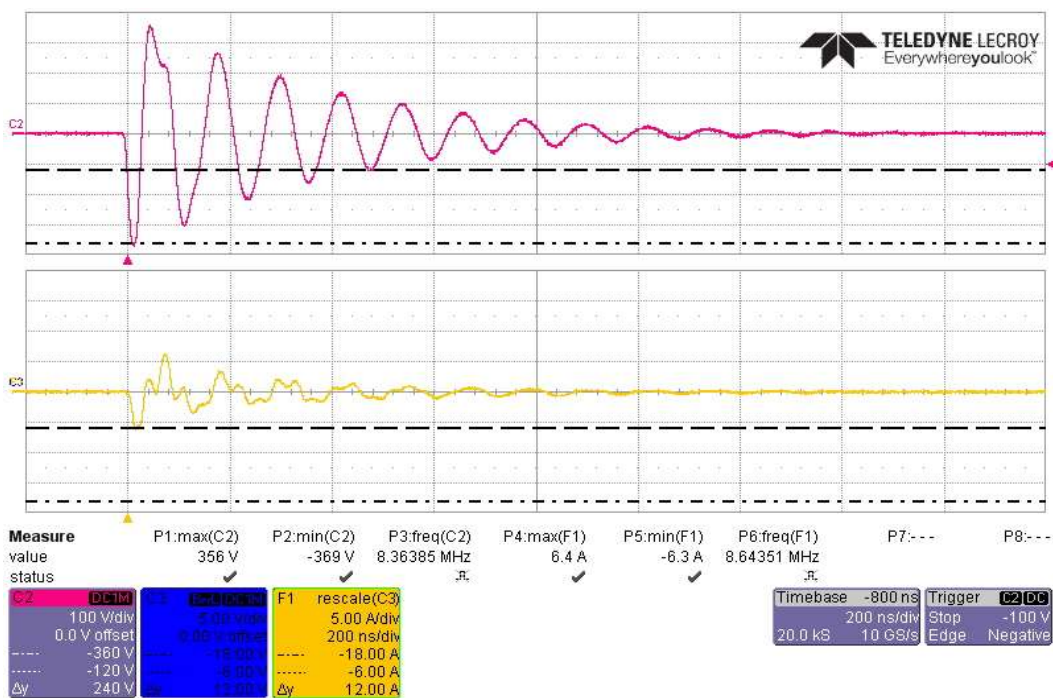

Actual Test CS117 Waveform #3 at 10MHz, First Transient -360V/6A, on Battery High Side

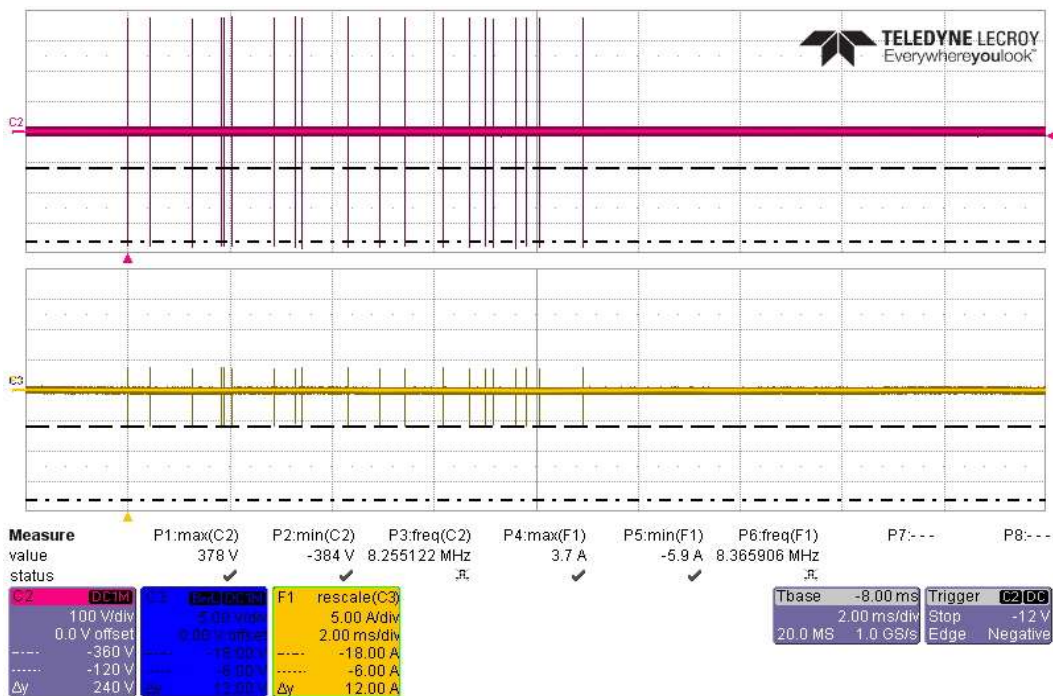

Actual Test CS117 Waveform #3 at 10MHz, 20 Transients -360V/6A, on Battery High Side

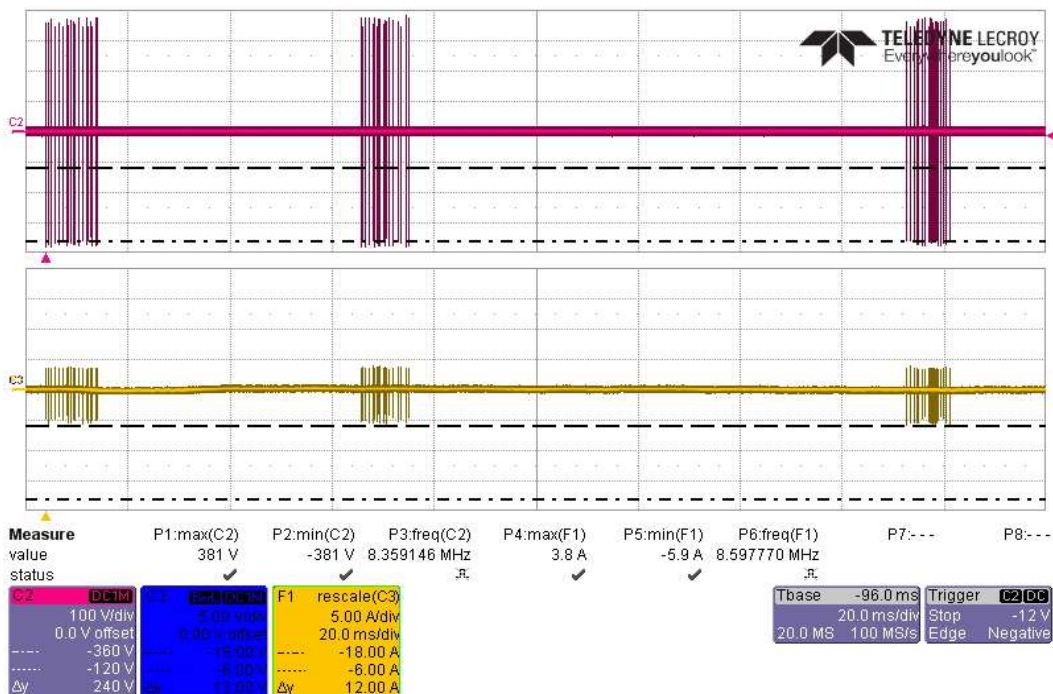

Actual Test CS117 Waveform #3 at 10MHz, 3 Bursts -360V/6A, on Battery High Side

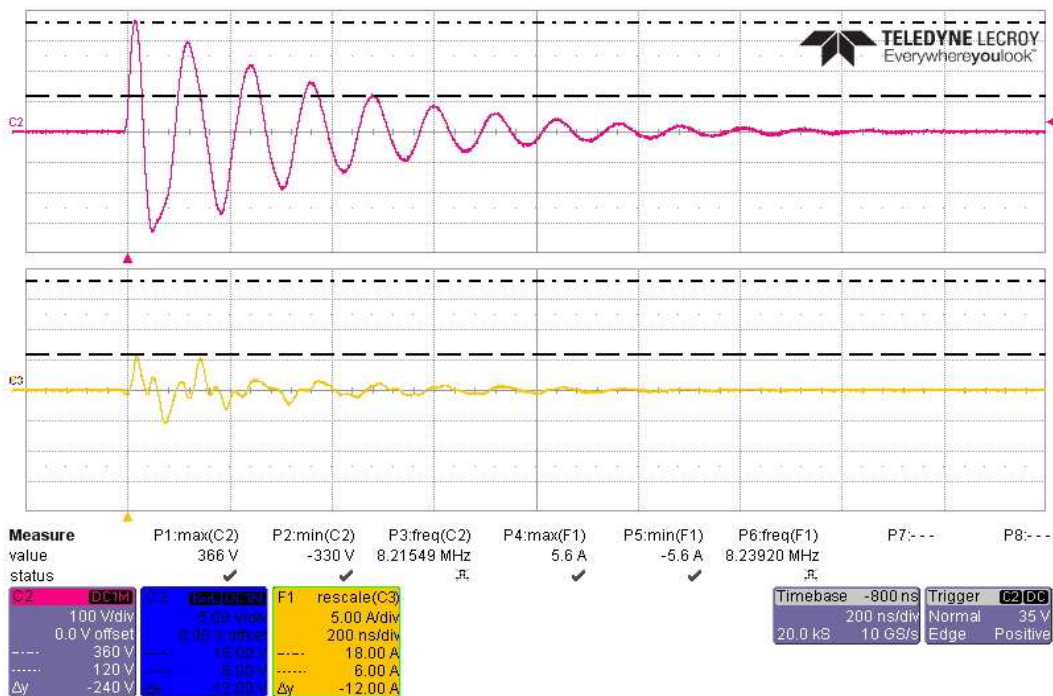

Actual Test CS117 Waveform #3 at 10MHz, First Transient +360V/6A, on Battery Return Side

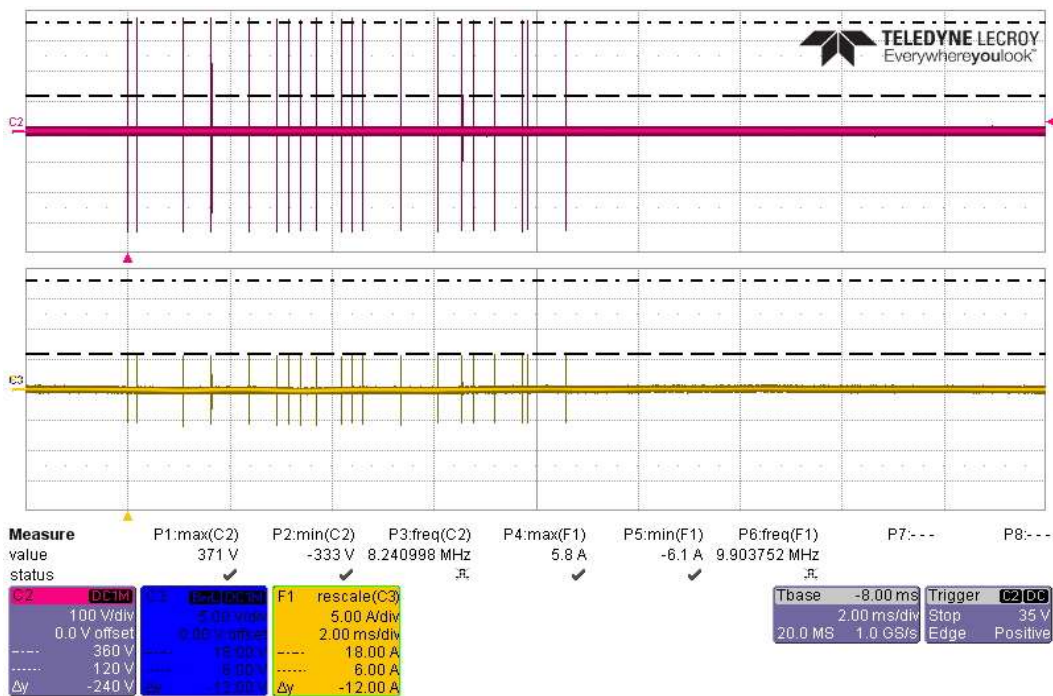

Actual Test CS117 Waveform #3 at 10MHz, 20 Transients +360V/6A, on Battery Return Side

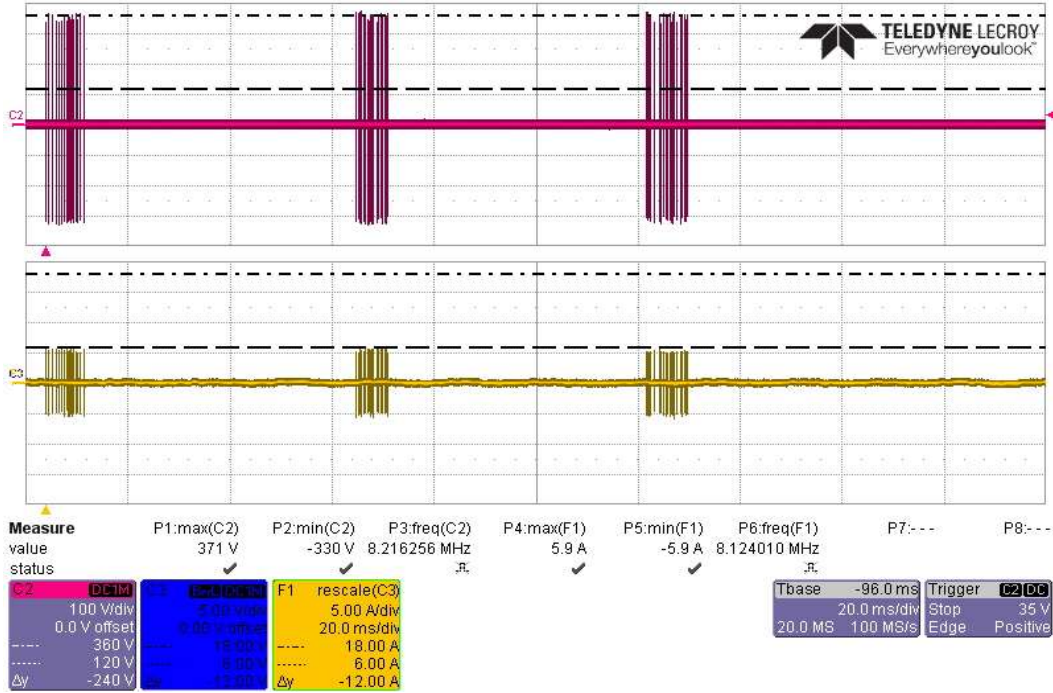

Actual Test CS117 Waveform #3 at 10MHz, 3 Bursts +360V/6A, on Battery Return Side

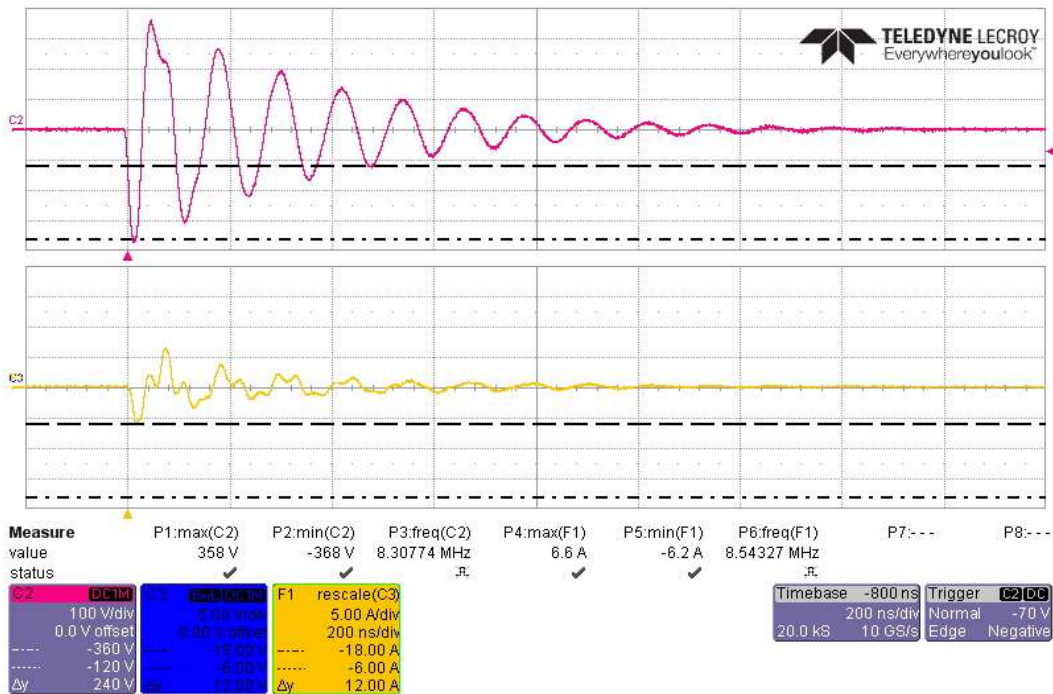

Actual Test CS117 Waveform #3 at 10MHz, First Transient -360V/6A, on Battery Return Side

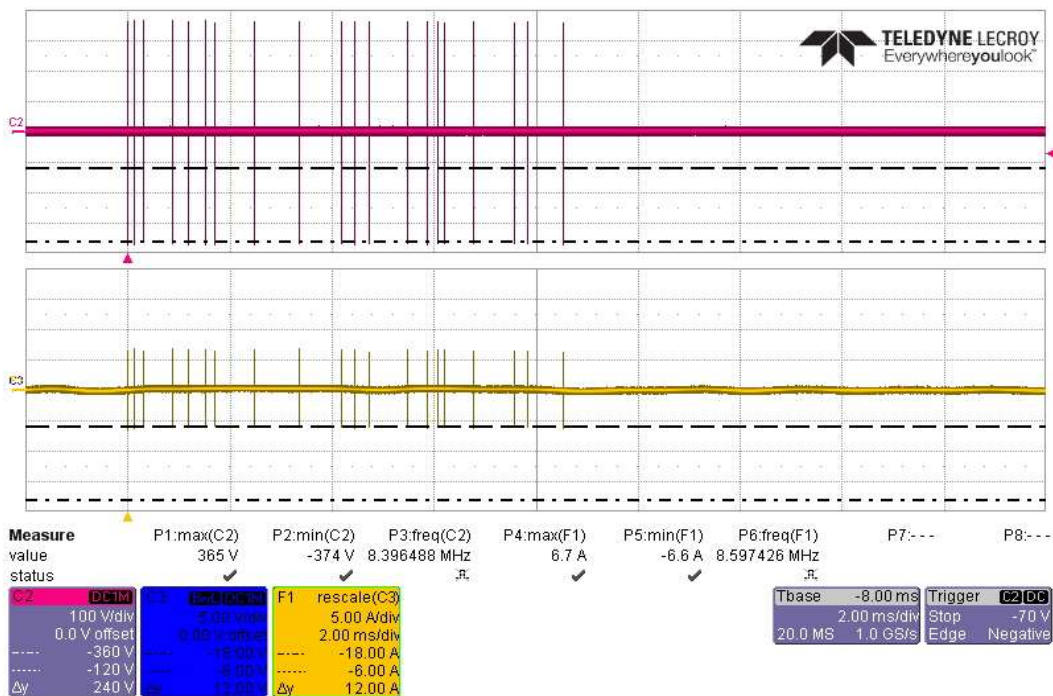

Actual Test CS117 Waveform #3 at 10MHz, 20 Transients -360V/6A, on Battery Return Side

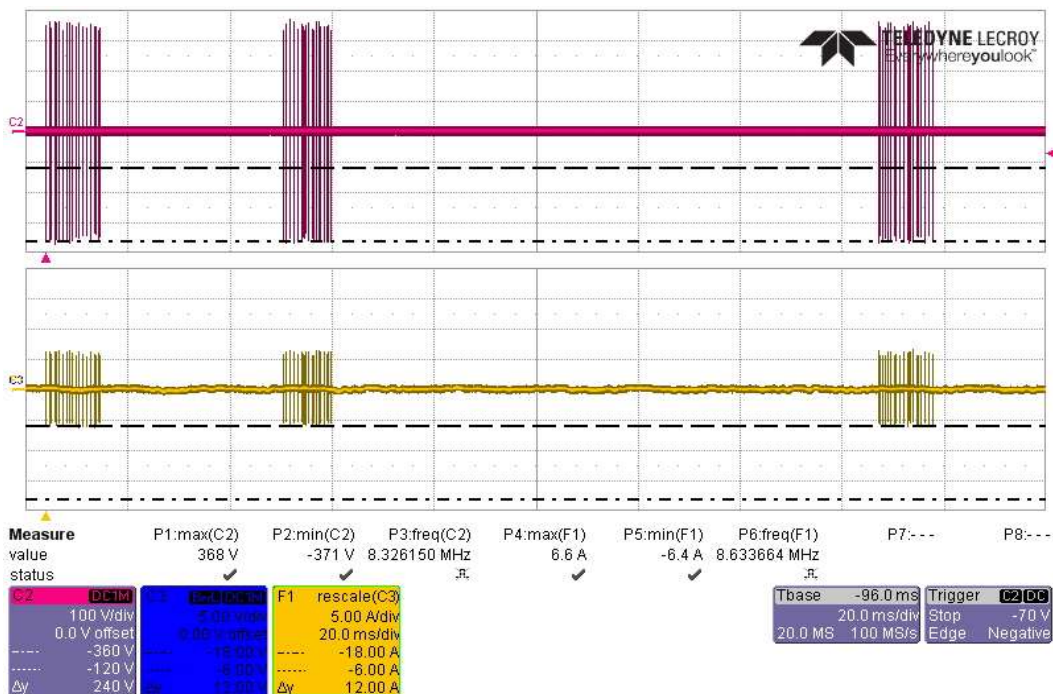

Actual Test CS117 Waveform #3 at 10MHz, 3 Bursts -360V/6A, on Battery Return Side

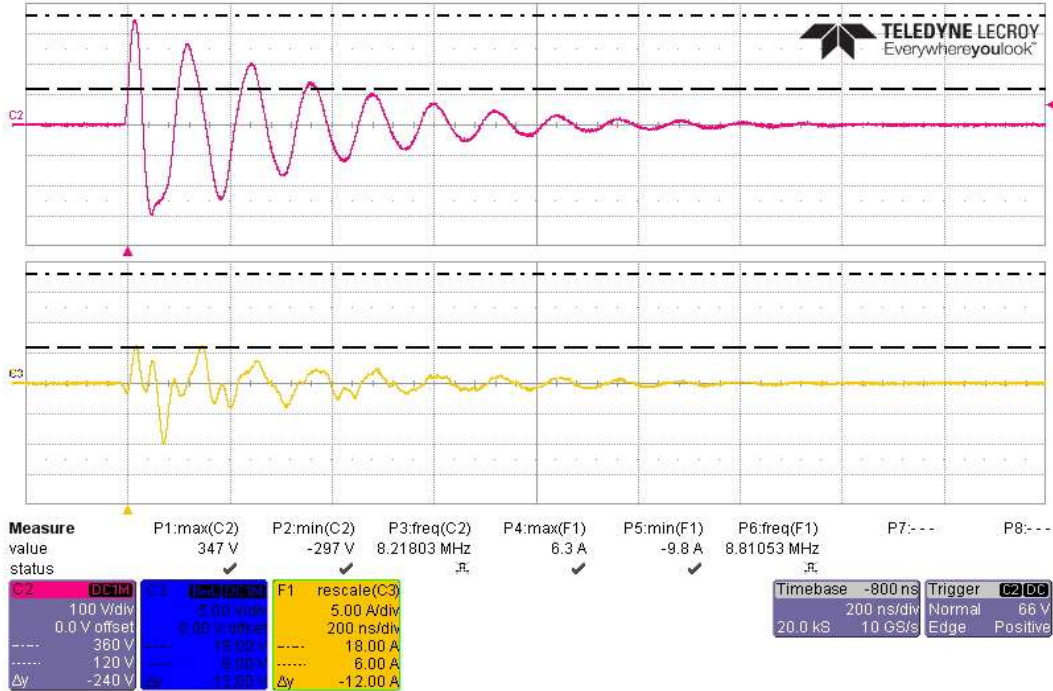

Actual Test CS117 Waveform #3 at 10MHz, First Transient +360V/6A, on Battery Bundle

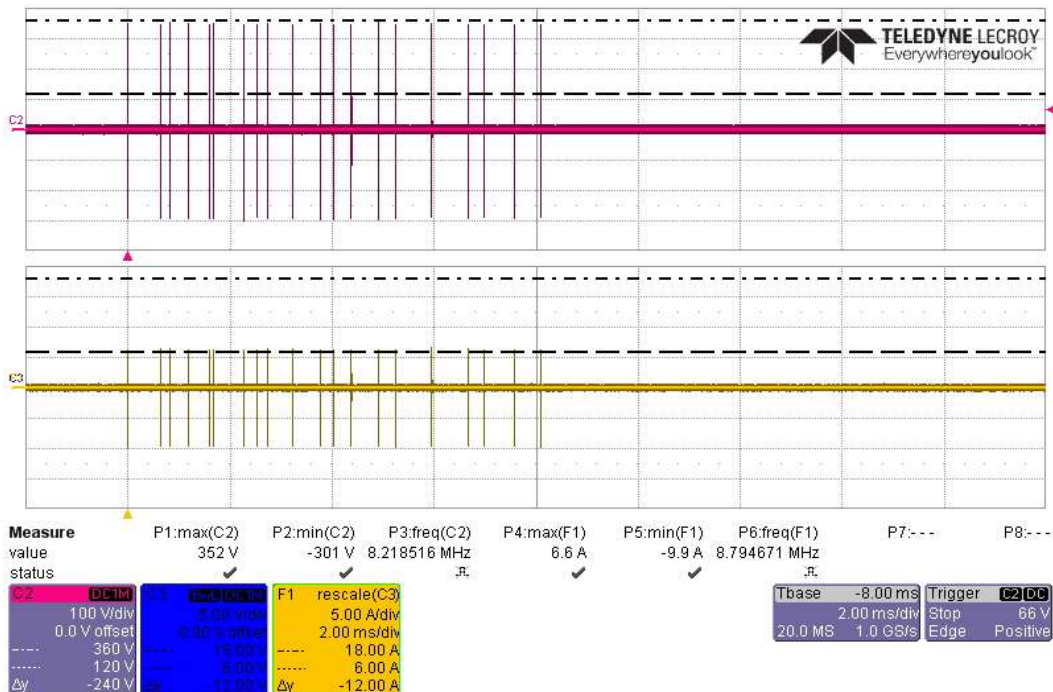

Actual Test CS117 Waveform #3 at 10MHz, 20 Transients +360V/6A, on Battery Bundle

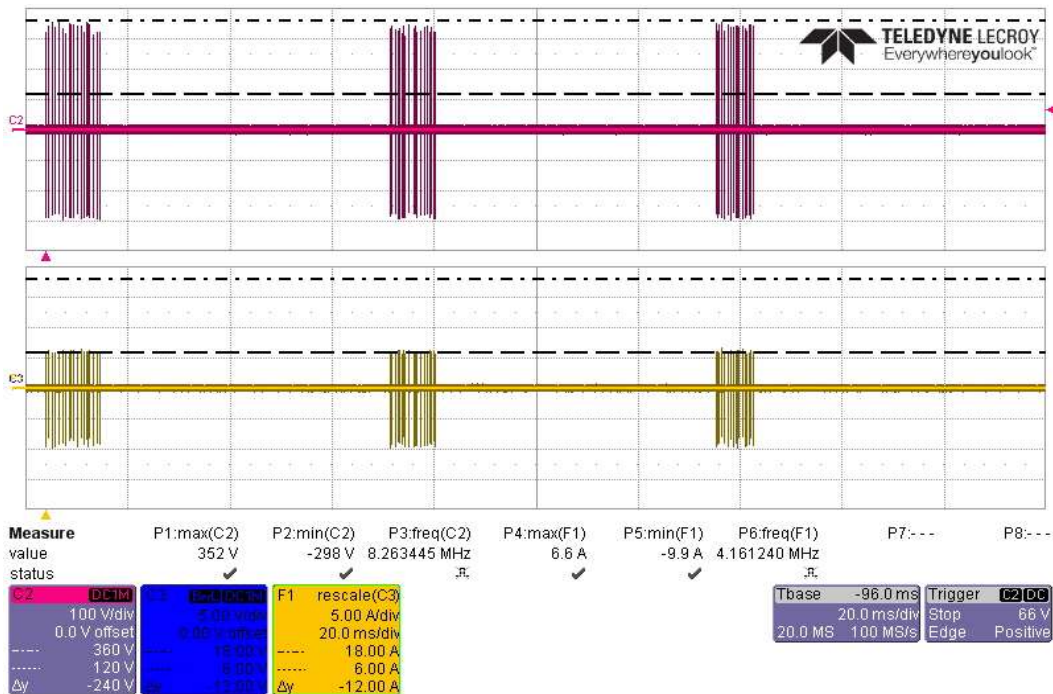

Actual Test CS117 Waveform #3 at 10MHz, 3 Bursts +360V/6A, on Battery Bundle

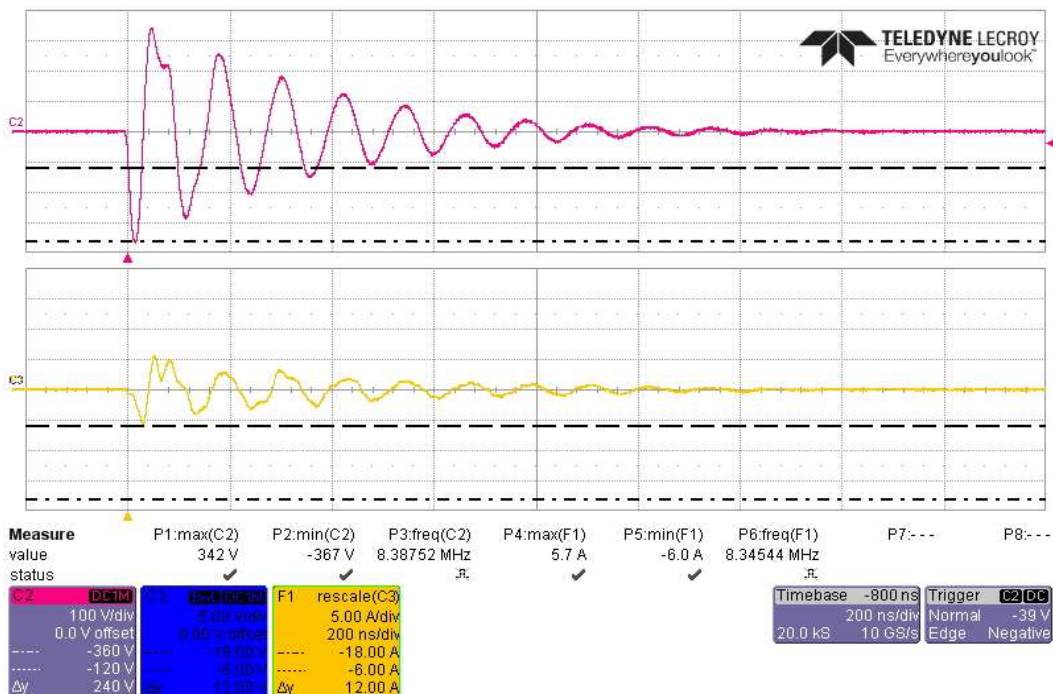

Actual Test CS117 Waveform #3 at 10MHz, First Transient -360V/6A, on Battery Bundle

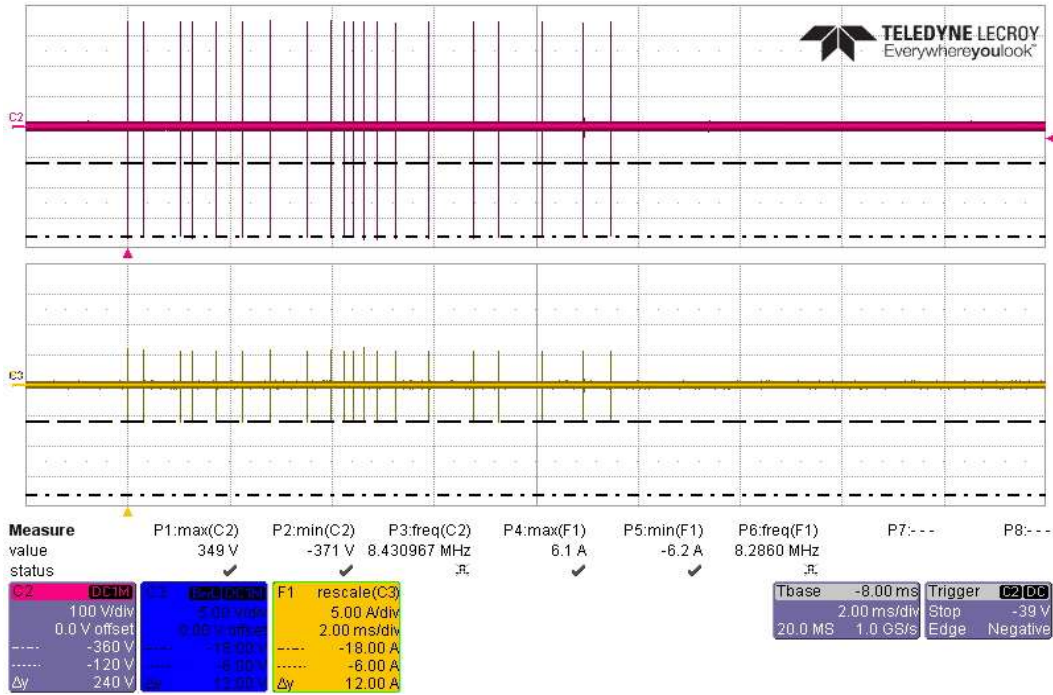

Actual Test CS117 Waveform #3 at 10MHz, 20 Transients -360V/6A, on Battery Bundle

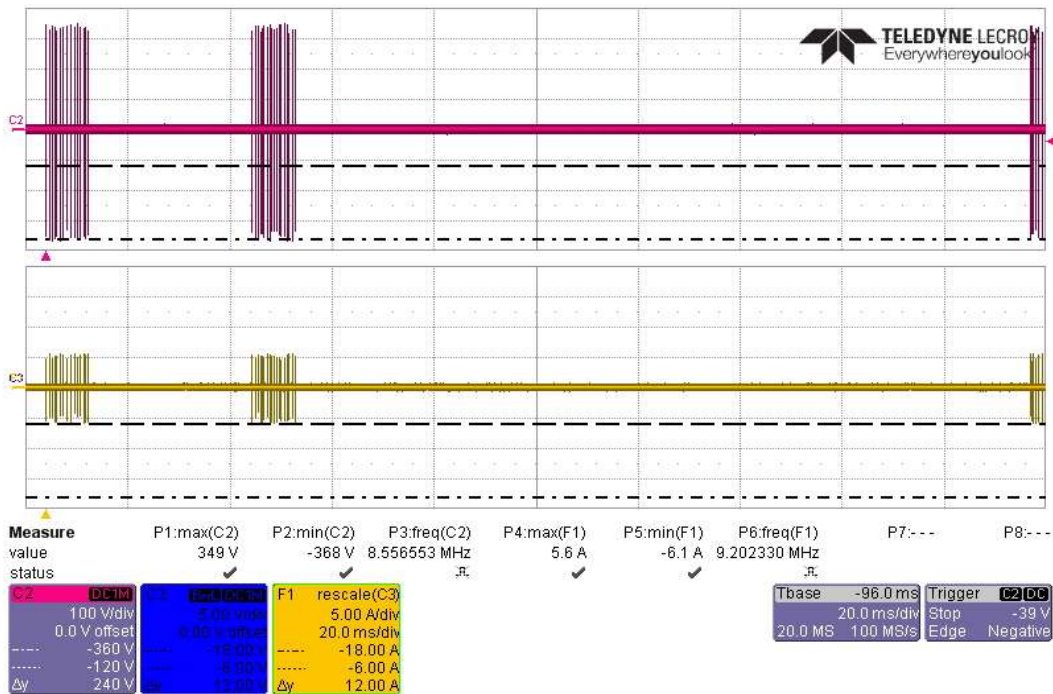

Actual Test CS117 Waveform #3 at 10MHz, 3 Bursts -360V/6A, on Battery Bundle

5.3.2 CS117 Test Data on Battery Wall Mount

CUSTOMER:	EG4 Electronics LLC	MJO:	PRI83529		
TEST ITEM:	Battery Wall Mount	DATE:	7/1/24		
PART NUMBER:	WP-16/280-1-AWLL	UNIT NO:	SC2023113739		
SPECIFICATION:	MIL-STD-461G	CHAMBER NO:	Workbench 1		
EUT Power Input:		DC (Battery Only)			
MIL-STD-461G CS117 Lightning Induced Transient Susceptibility					
Temperature: 85F	Humidity: 42% RH		Barometric Pressure: 981 mBar		
Internal Equipment Levels	Test Level	Test On	Results		Comments
Waveform #1 MS	300VL_60At/150VL_30At	Battery High Side	<input checked="" type="checkbox"/> Pass	<input type="checkbox"/> Fail	
Waveform #1 MS	300VL_60At/150VL_30At	Battery Return Side	<input checked="" type="checkbox"/> Pass	<input type="checkbox"/> Fail	
Waveform #1 MS	300VL_120At/150VL_60At	Battery Bundle	<input type="checkbox"/> Pass	<input type="checkbox"/> Fail	N/A - VL reached 1st - WF2 Required
Waveform #2 MS	300Vt_120AL/150Vt_60AL	Battery Bundle	<input checked="" type="checkbox"/> Pass	<input type="checkbox"/> Fail	
Waveform #3 MS at 1MHz & 10MHz	600V_24A/300V_12A	Battery High Side	<input checked="" type="checkbox"/> Pass	<input type="checkbox"/> Fail	
Waveform #3 MS at 1MHz & 10MHz	600V_24A/300V_12A	Battery Return Side	<input checked="" type="checkbox"/> Pass	<input type="checkbox"/> Fail	
Waveform #3 MS at 1MHz & 10MHz	600V_48A/300V_24A	Battery Bundle	<input checked="" type="checkbox"/> Pass	<input type="checkbox"/> Fail	
Waveform #3 MB at 1MHz & 10MHz	360Vt_6AL	Battery High Side	<input checked="" type="checkbox"/> Pass	<input type="checkbox"/> Fail	
Waveform #3 MB at 1MHz & 10MHz	360Vt_6AL	Battery Return Side	<input checked="" type="checkbox"/> Pass	<input type="checkbox"/> Fail	
Waveform #3 MB at 1MHz & 10MHz	360Vt_6AL	Battery Bundle	<input checked="" type="checkbox"/> Pass	<input type="checkbox"/> Fail	
TECHNICIAN / ENGINEER:		Donald Adams	DATE:	7/2/2024	

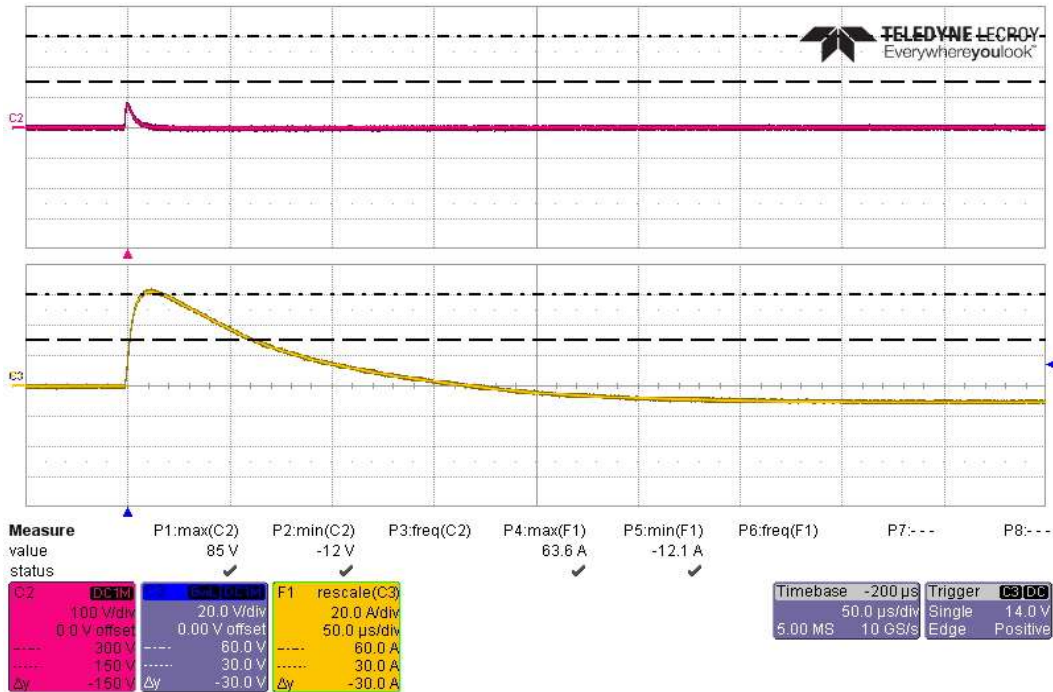
CS117 Actual Test Multiple Stroke Current Waveform #1 at 60A

Actual Test CS117 Waveform #1, First Transient +60A, on Battery High Side

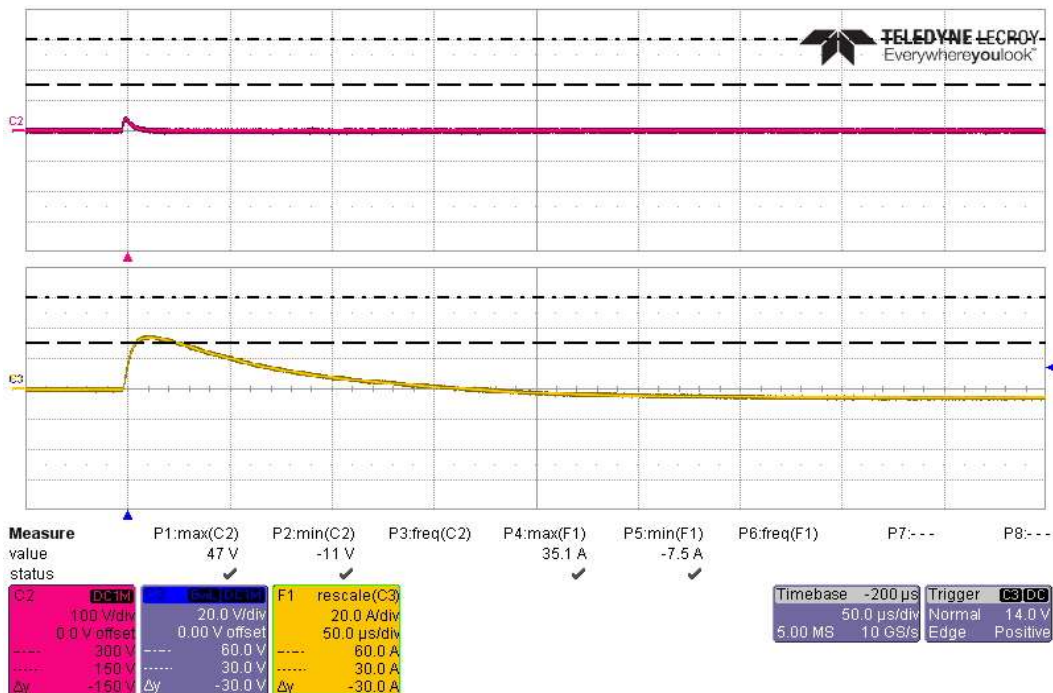

Actual Test CS117 Waveform #1, Subsequent Transient +30A, on Battery High Side

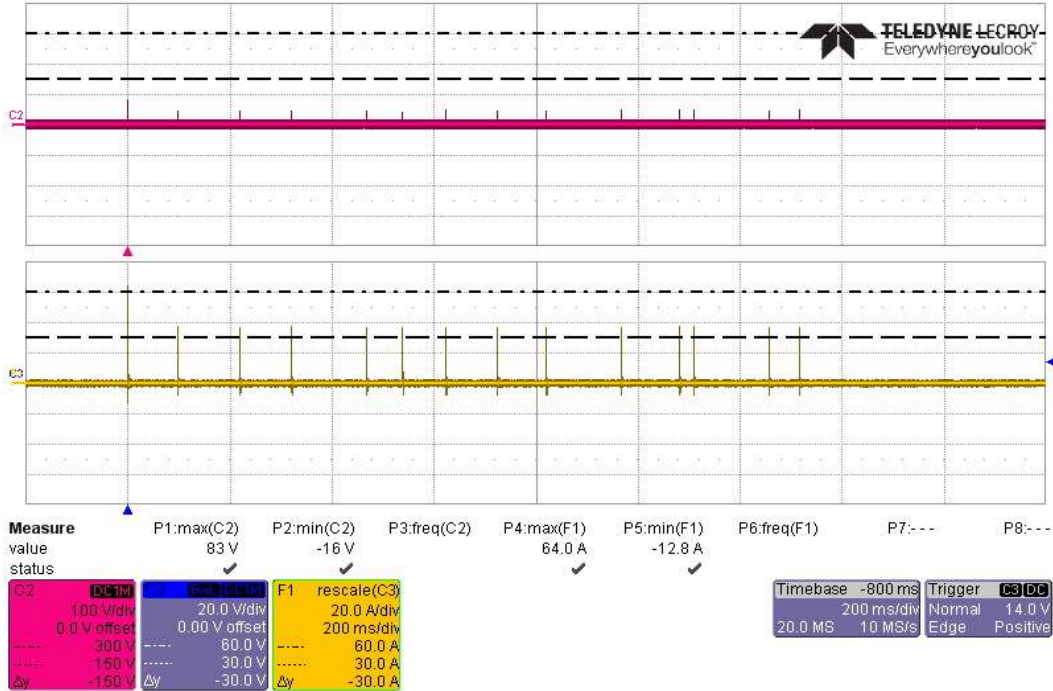

Actual Test CS117 Waveform #1, 14 Transients +60A/30A, on Battery High Side

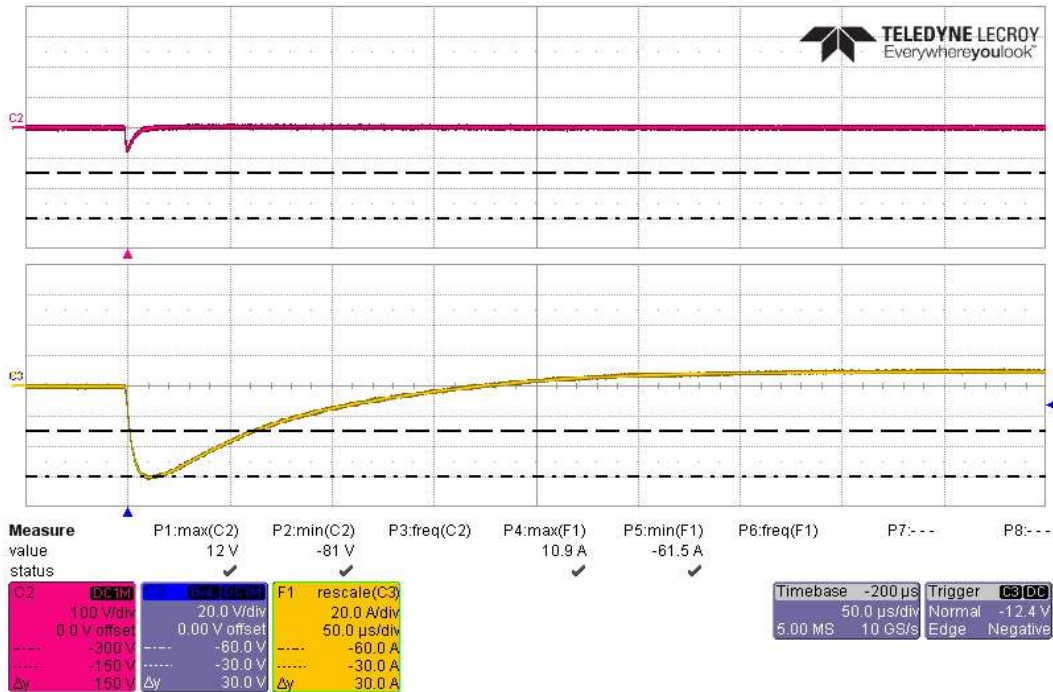

Actual Test CS117 Waveform #1, First Transient -60A, on Battery High Side

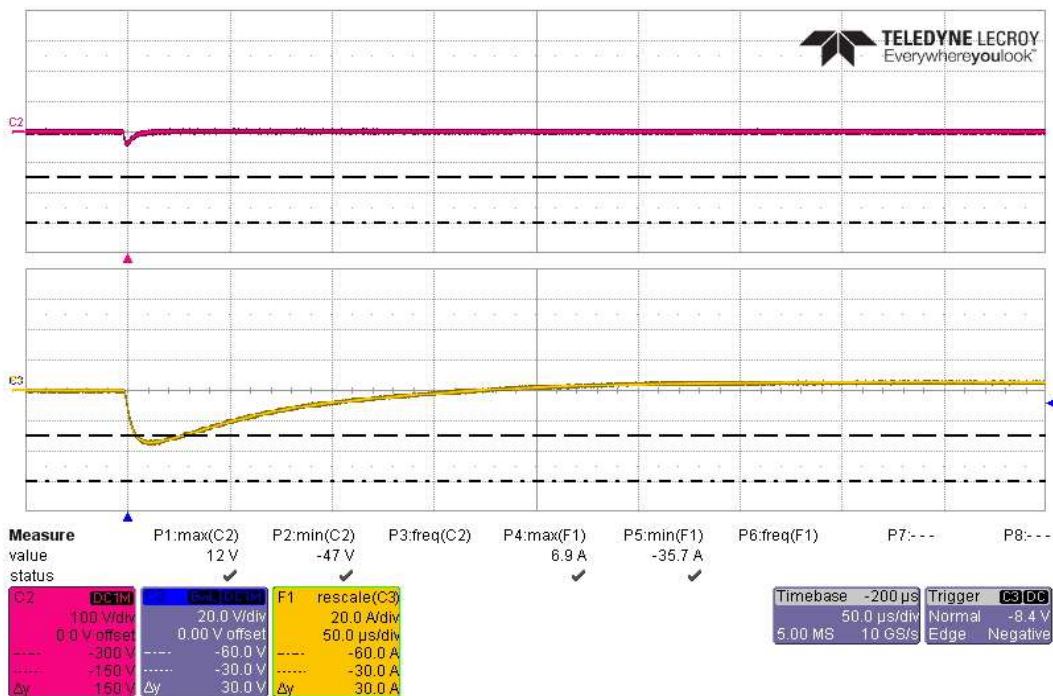

Actual Test CS117 Waveform #1, Subsequent Transient -30A, on Battery High Side

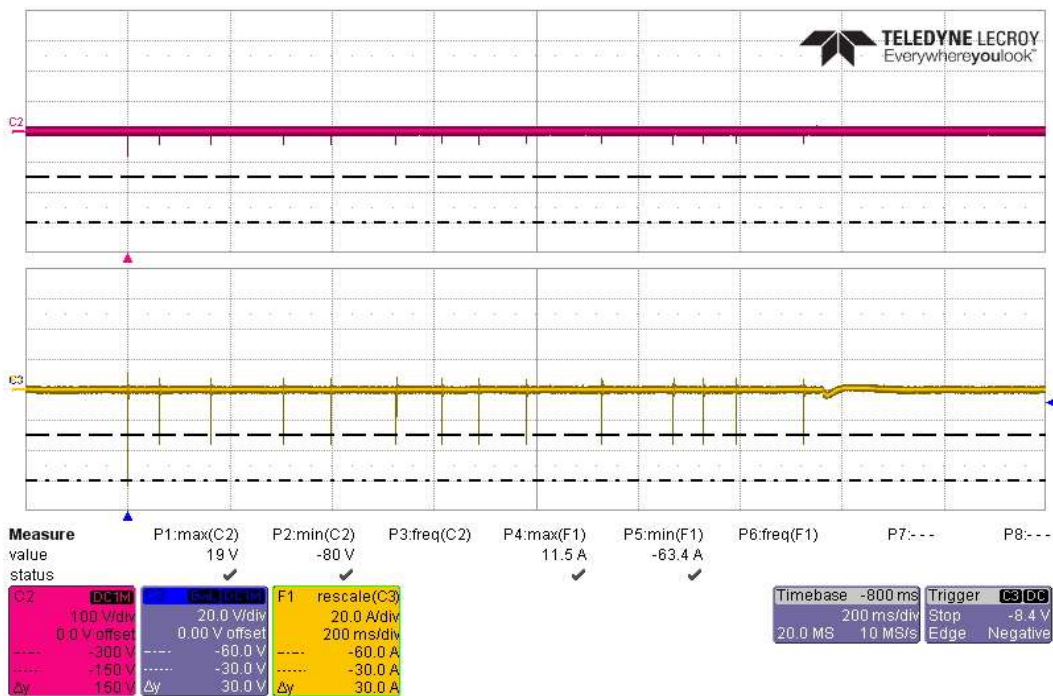

Actual Test CS117 Waveform #1, 14 Transients -60A/30A, on Battery High Side

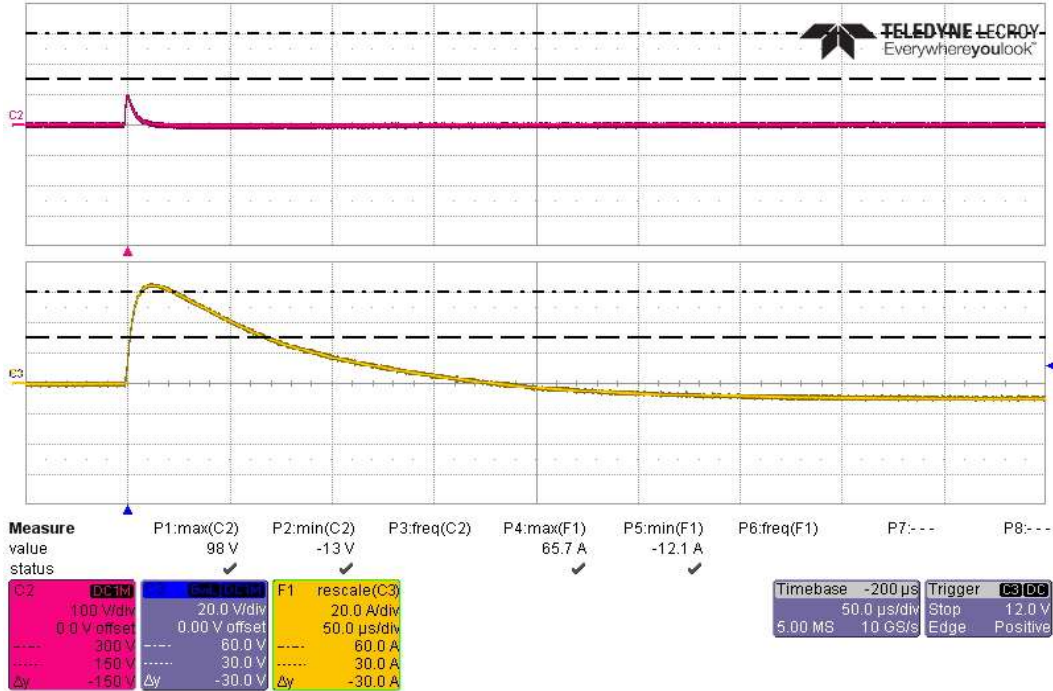

Actual Test CS117 Waveform #1, First Transient +60A, on Battery Return Side

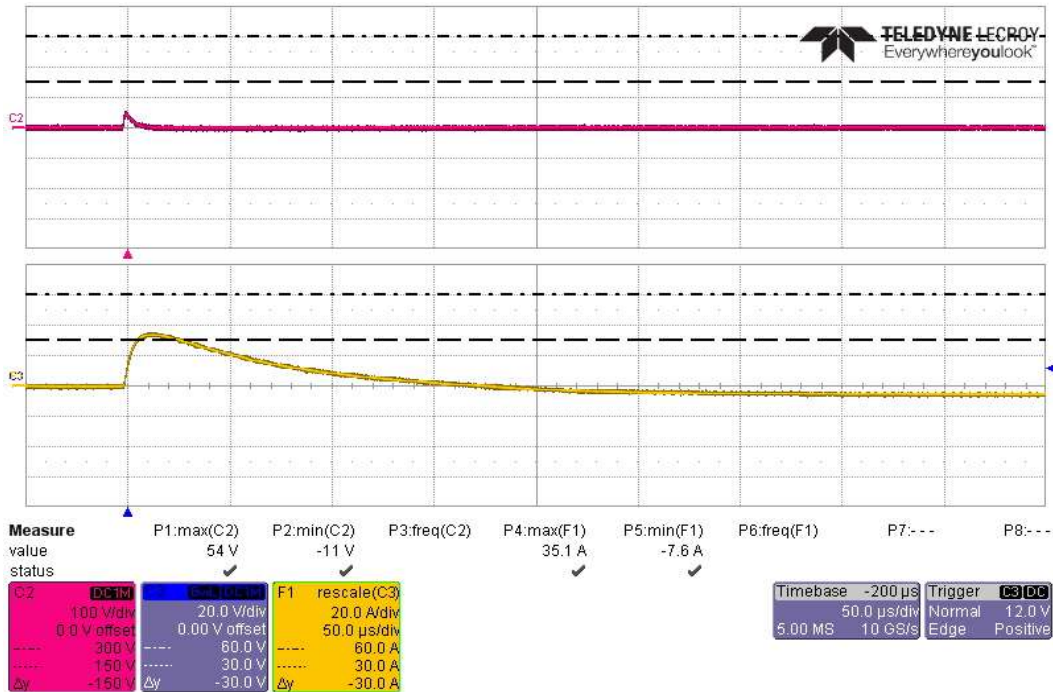

Actual Test CS117 Waveform #1, Subsequent Transient +30A, on Battery Return Side

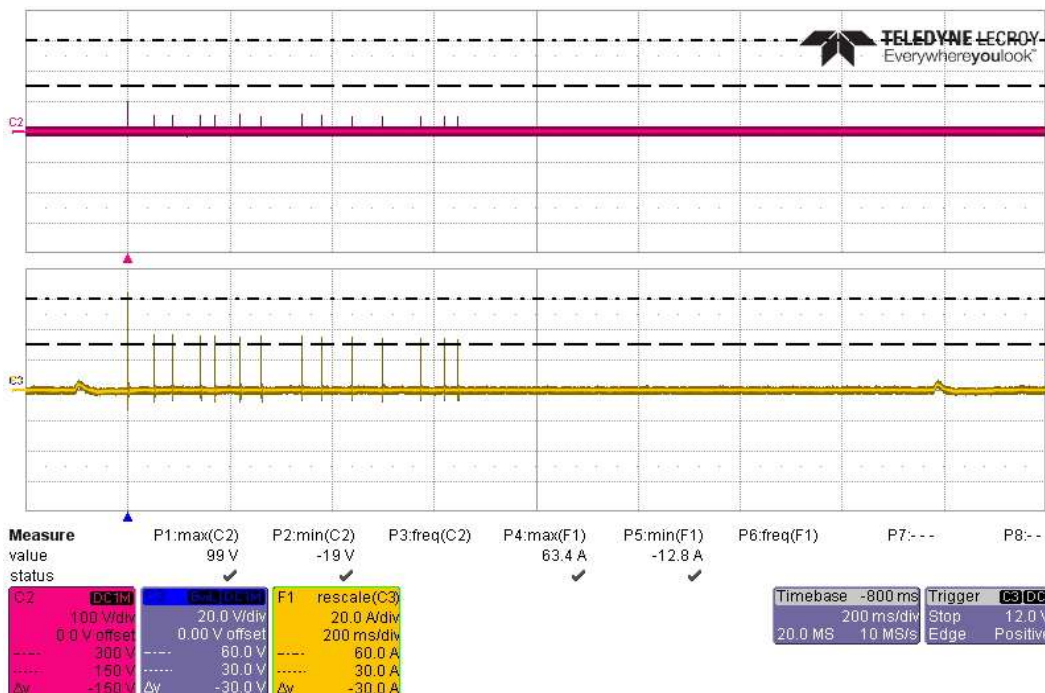

Actual Test CS117 Waveform #1, 14 Transients +60A/30A, on Battery Return Side

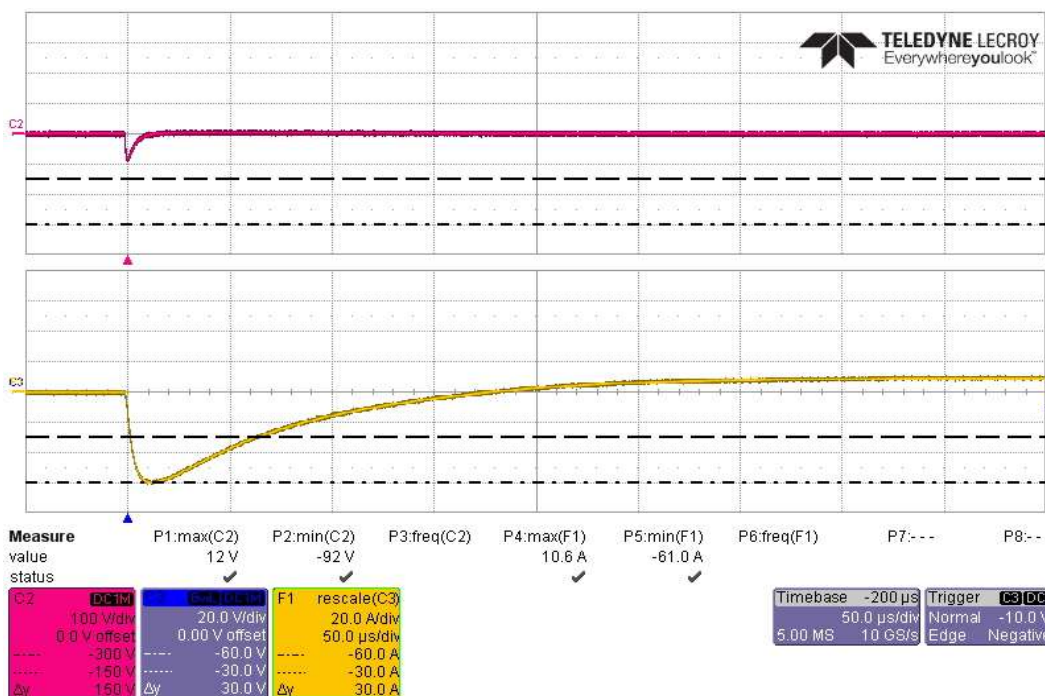

Actual Test CS117 Waveform #1, First Transient -60A, on Battery Return Side

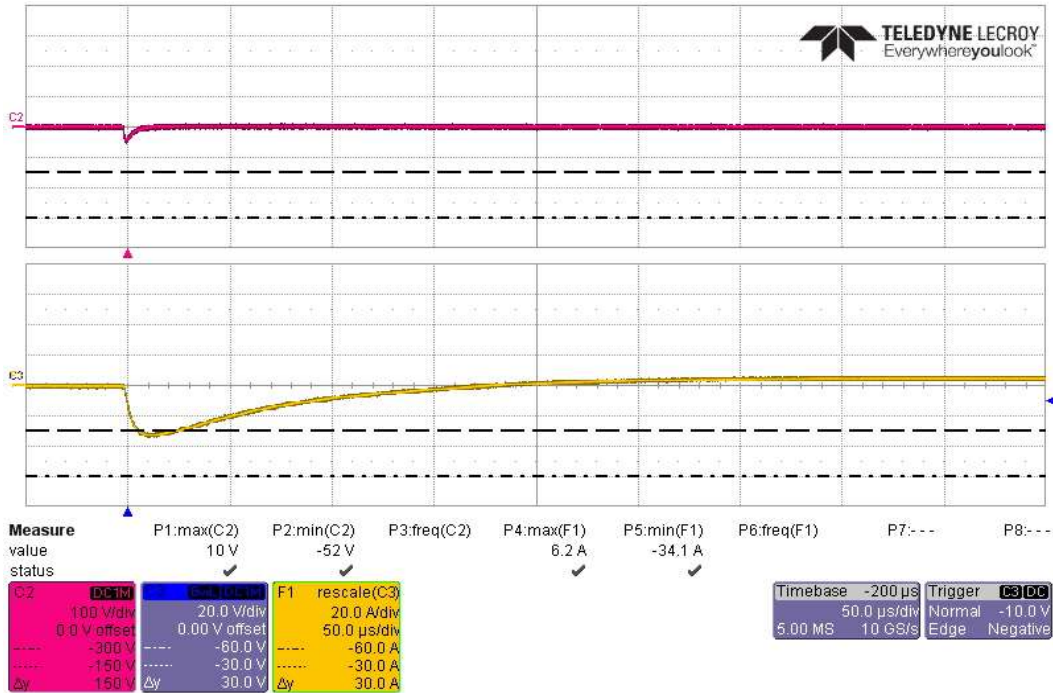

Actual Test CS117 Waveform #1, Subsequent Transient -30A, on Battery Return Side

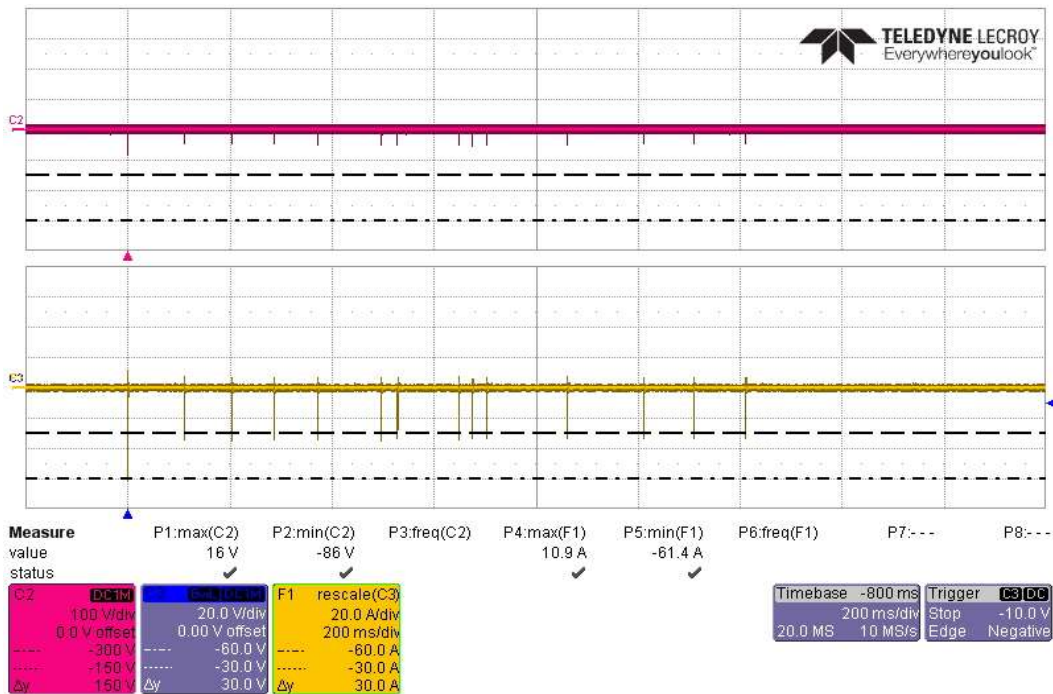

Actual Test CS117 Waveform #1, 14 Transients -60A/30A, on Battery Return Side

CS117 Actual Multiple Stroke Voltage Waveform #2 Test at 300V

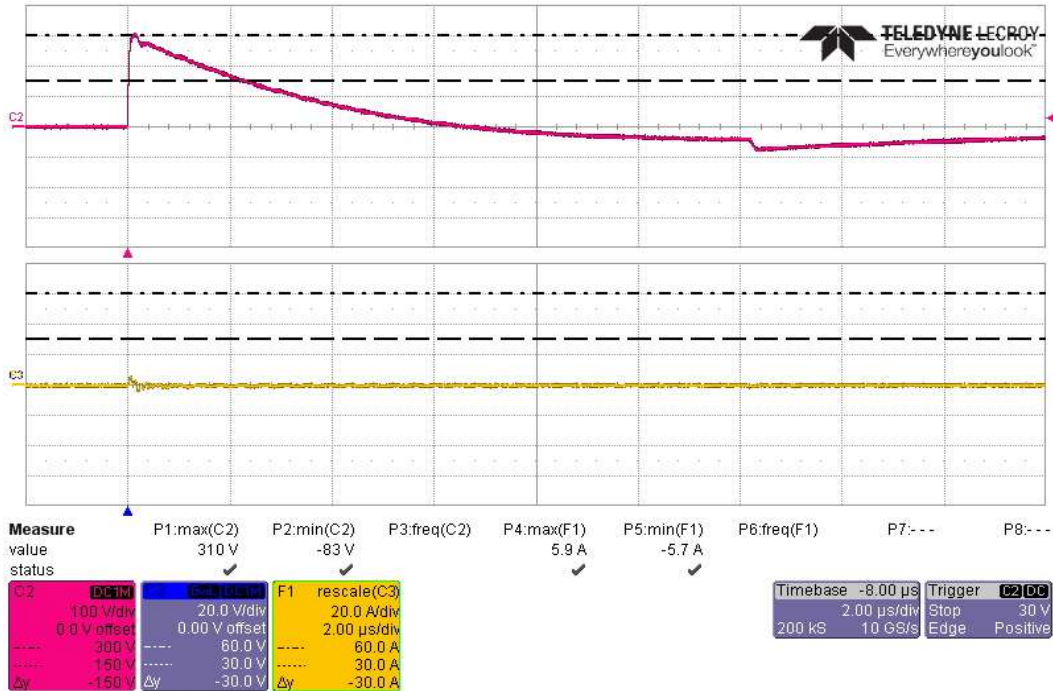

Actual CS117 Voltage Waveform #2 Test, First Transient +300V/120A on Battery Bundle

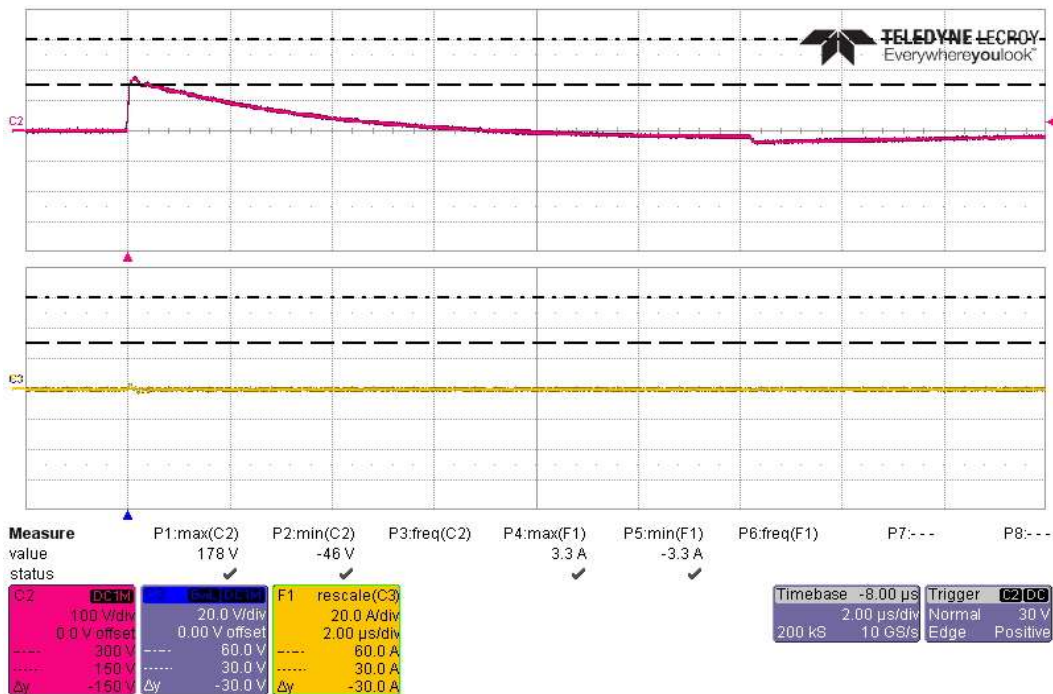

Actual CS117 Voltage Waveform #2 Test, Subsequent Transient +150V/60A on Battery Bundle

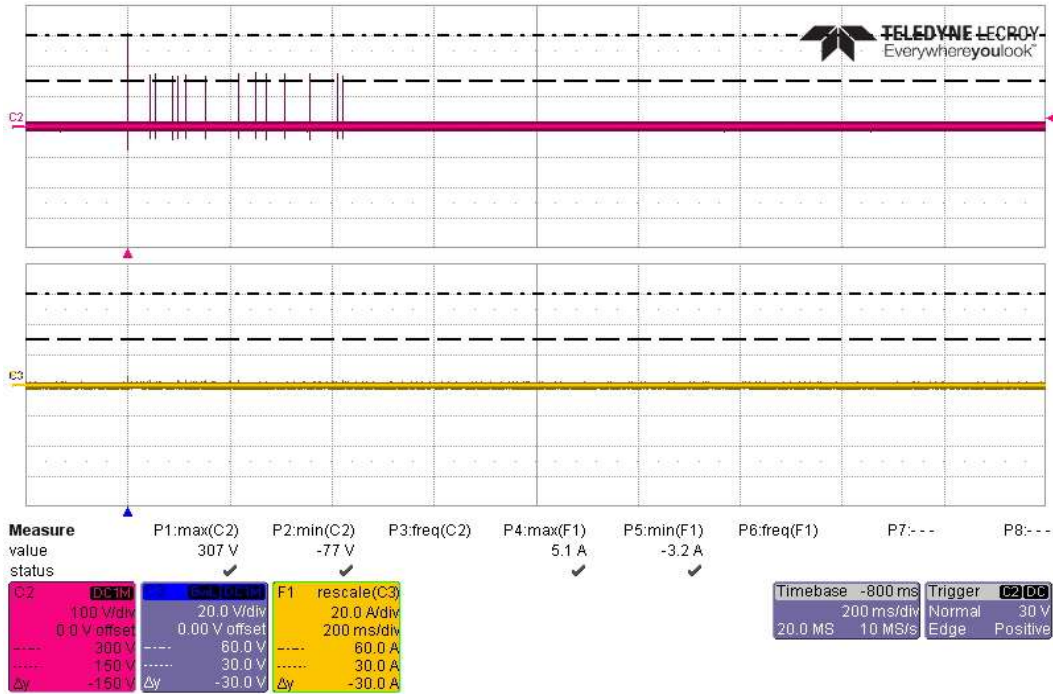

Actual CS117 Voltage Waveform #2 Test, 14 Transient +300V/120A & +150V/60A on Battery Bundle

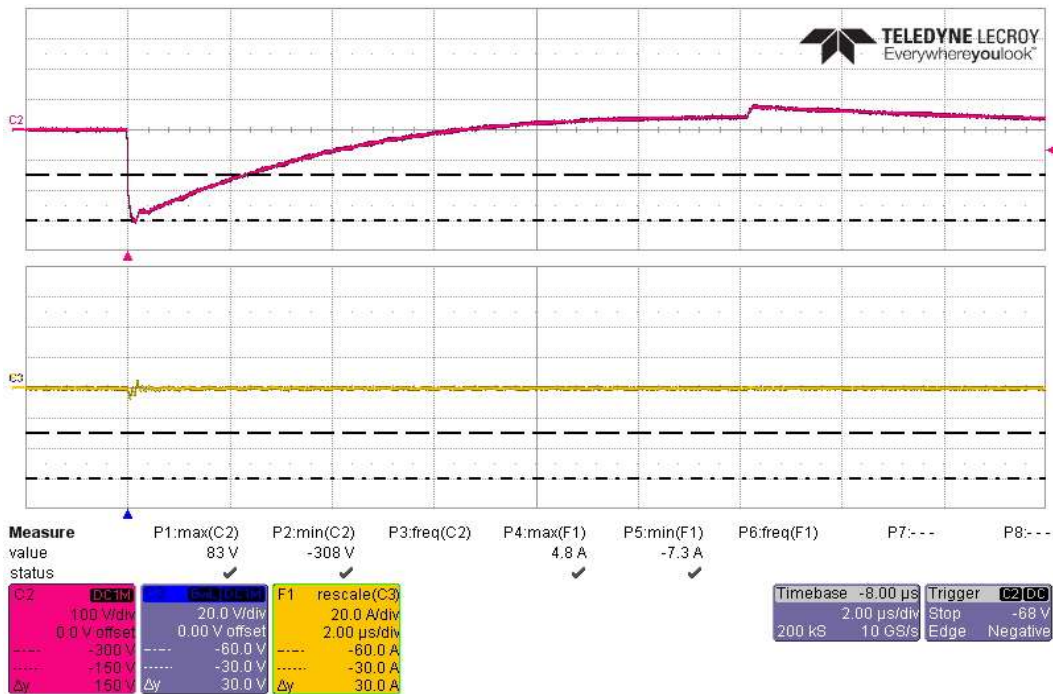

Actual CS117 Voltage Waveform #2 Test, First Transient -300V/120A on Battery Bundle

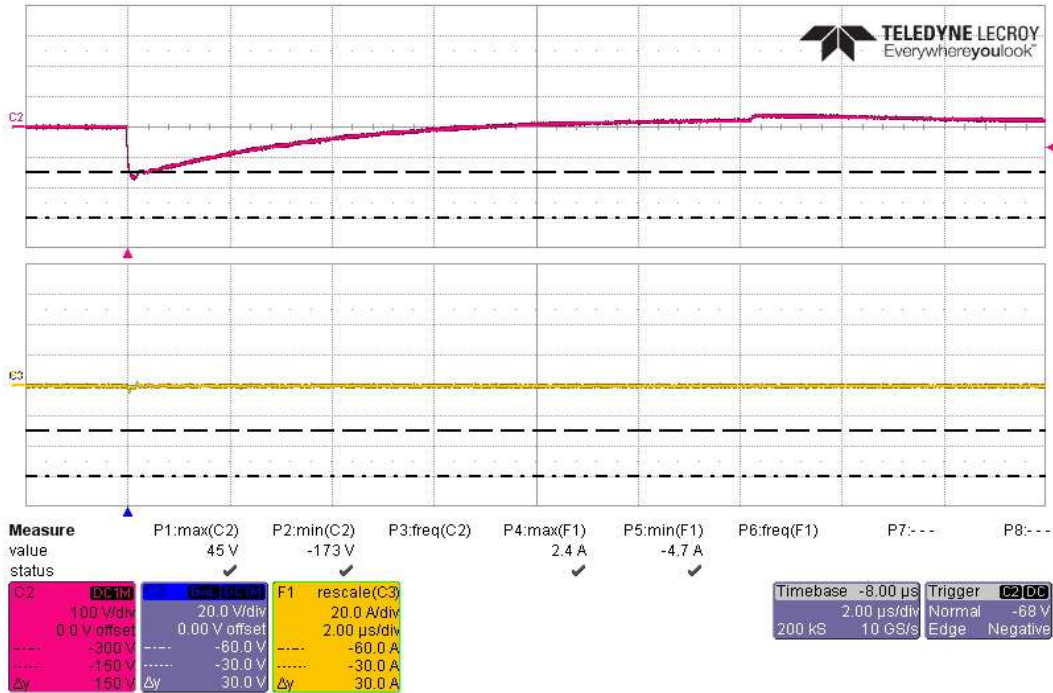

Actual CS117 Voltage Waveform #2 Test, Subsequent Transient -150V/60A on Battery Bundle

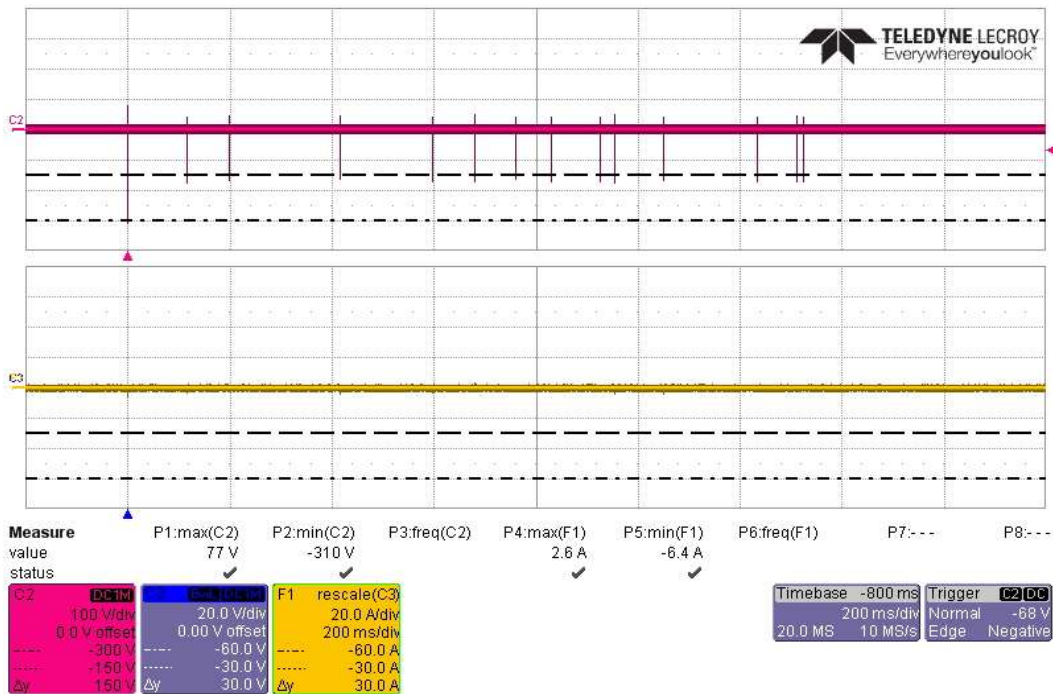

Actual CS117 Voltage Waveform #2 Test, 14 Transient -300V/120A & -150V/60A on Battery Bundle

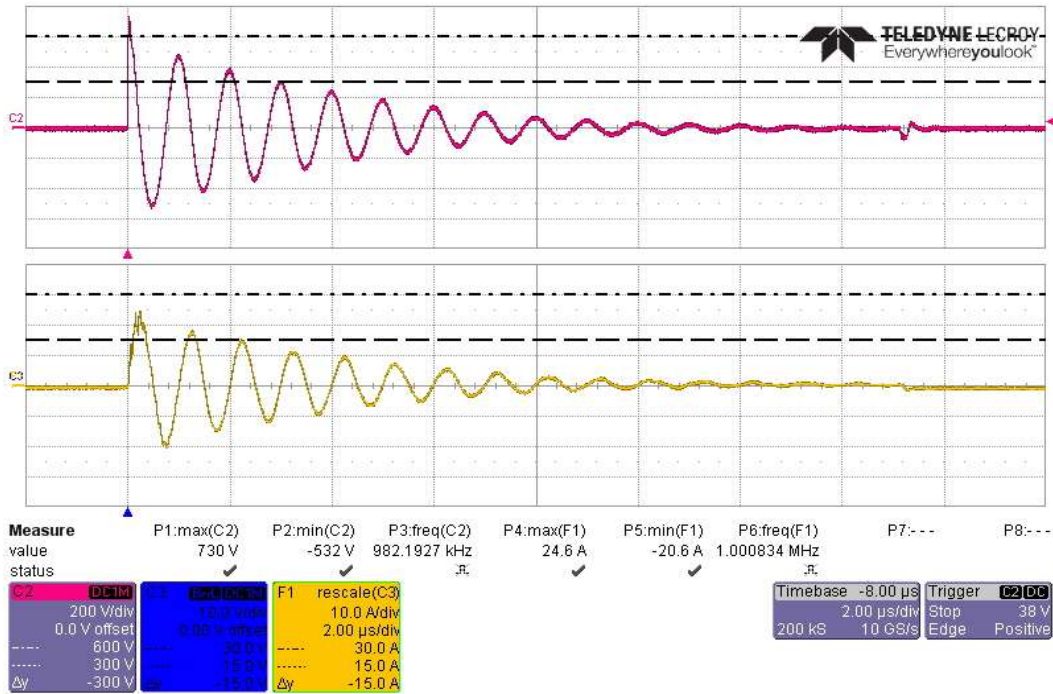
CS117 Actual Test Waveform #3 at 1MHz with 600V/24A

Actual Test CS117 Waveform #3 at 1MHz, First Transient +600V, on Battery High Side

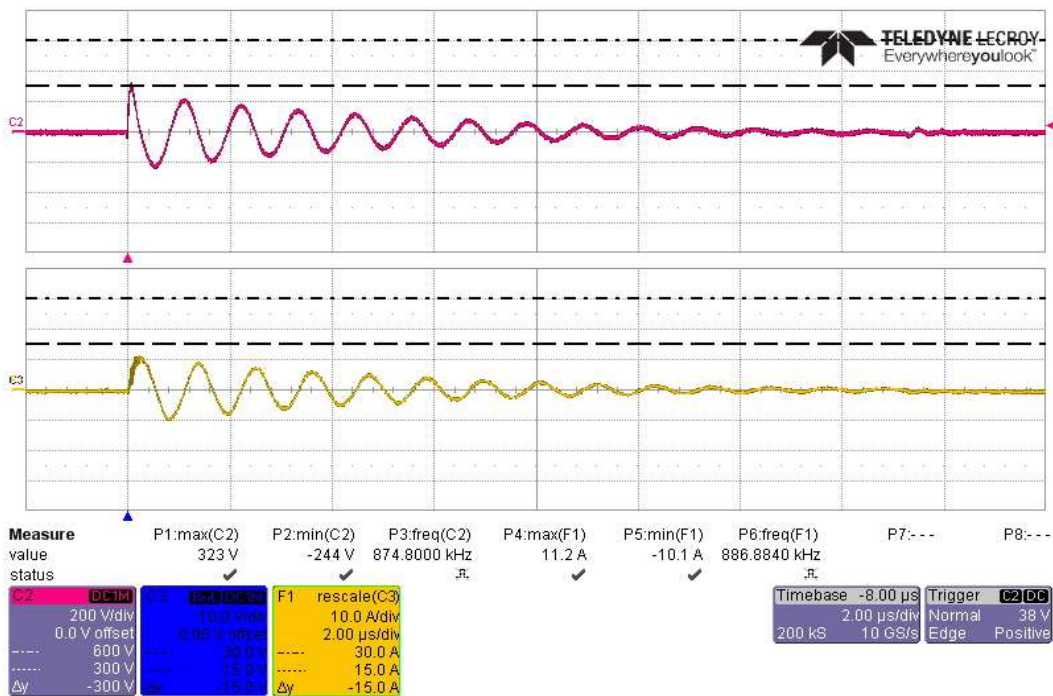

Actual Test CS117 Waveform #3 at 1MHz, Subsequent Transient +300V, on Battery High Side

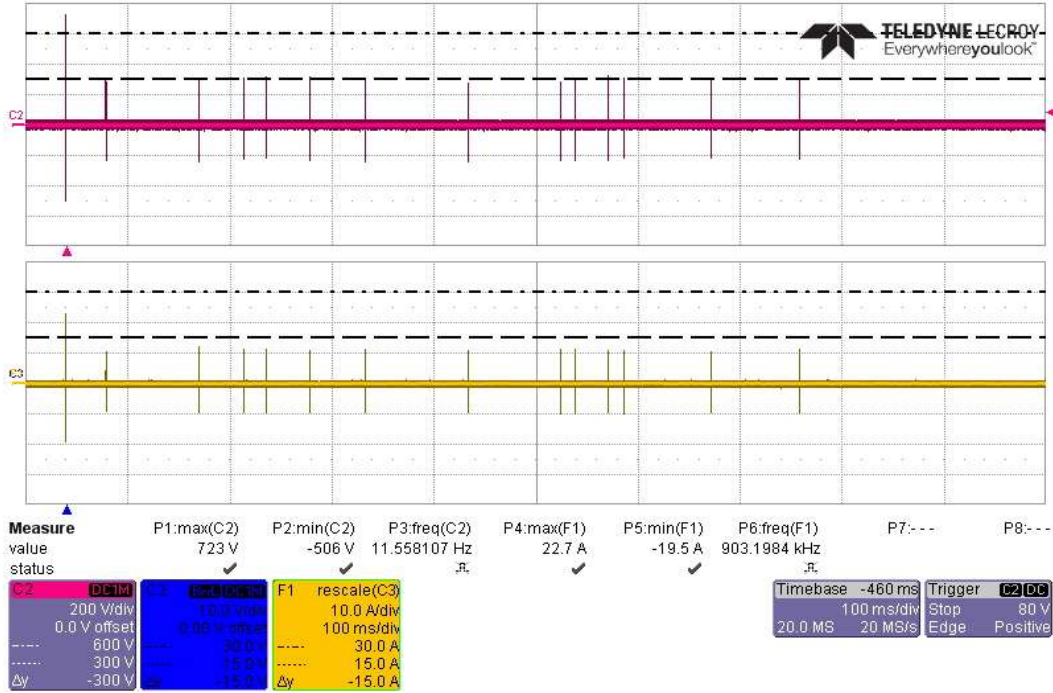

Actual Test CS117 Waveform #3 at 1MHz, 14 Transients +600/+300V, on Battery High Side

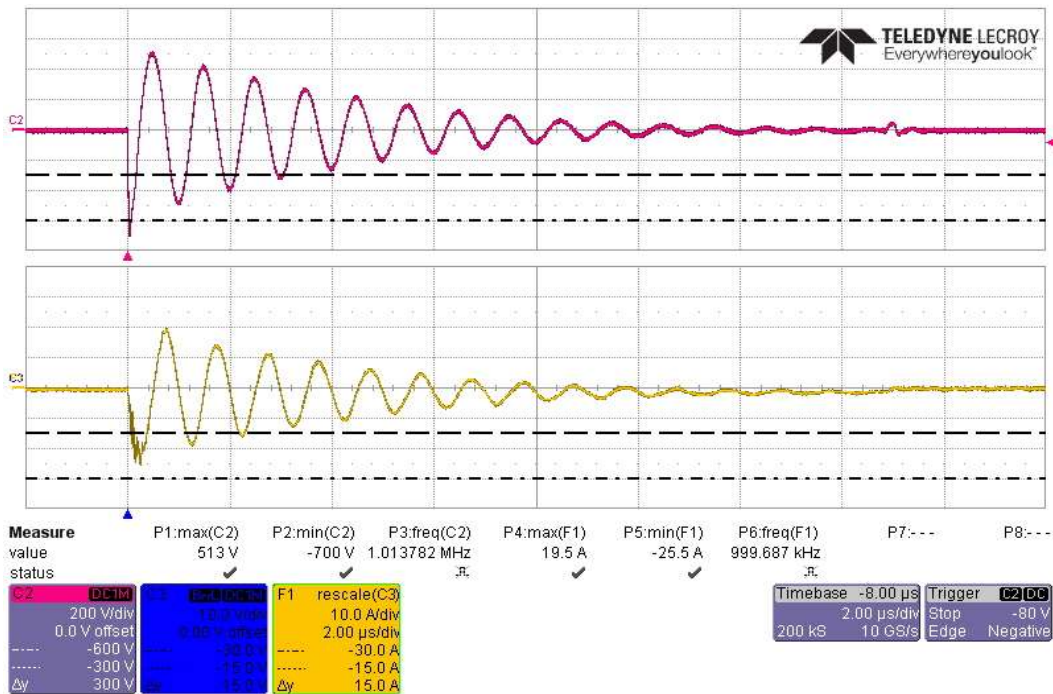

Actual Test CS117 Waveform #3 at 1MHz, First Transient -600V, on Battery High Side

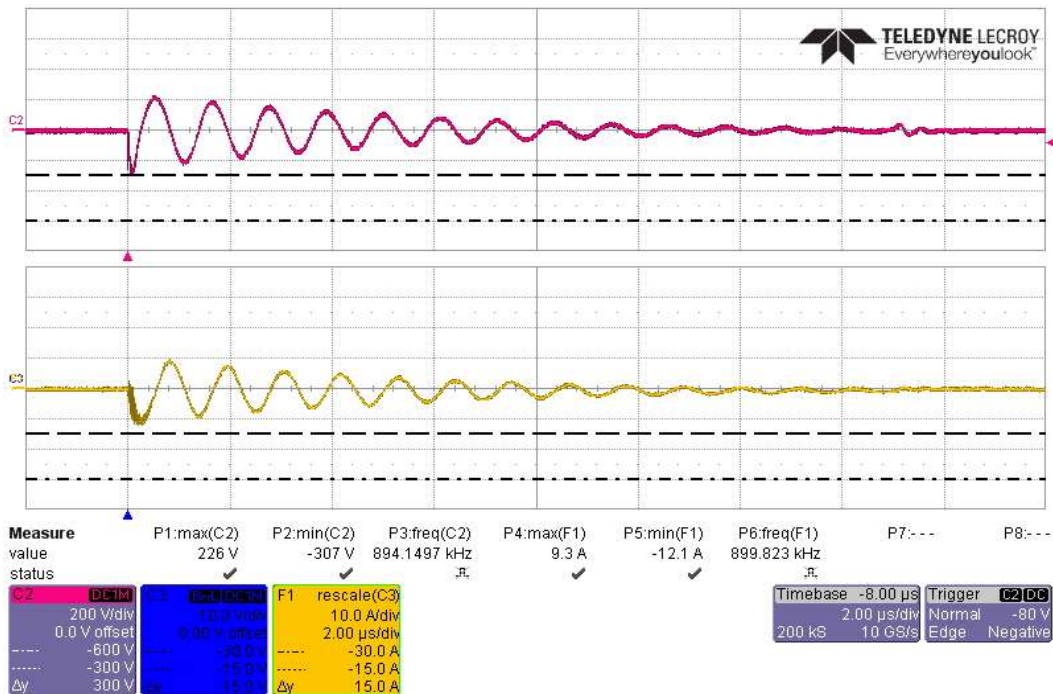

Actual Test CS117 Waveform #3 at 1MHz, Subsequent Transient -300V, on Battery High Side

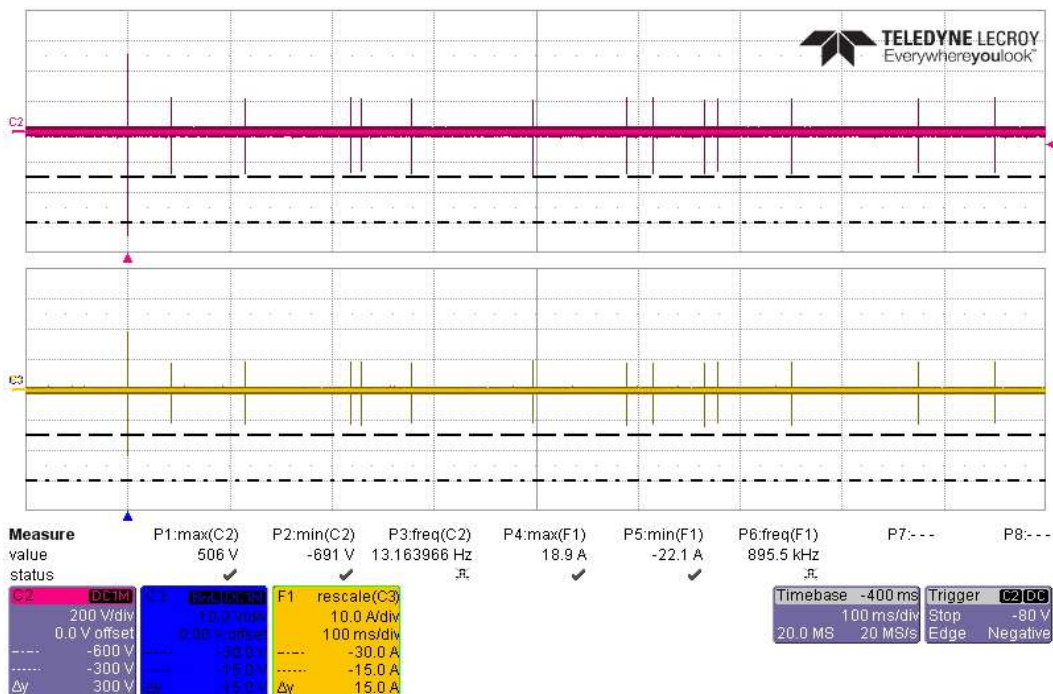

Actual Test CS117 Waveform #3 at 1MHz, 14 Transients -600/-300V, on Battery High Side

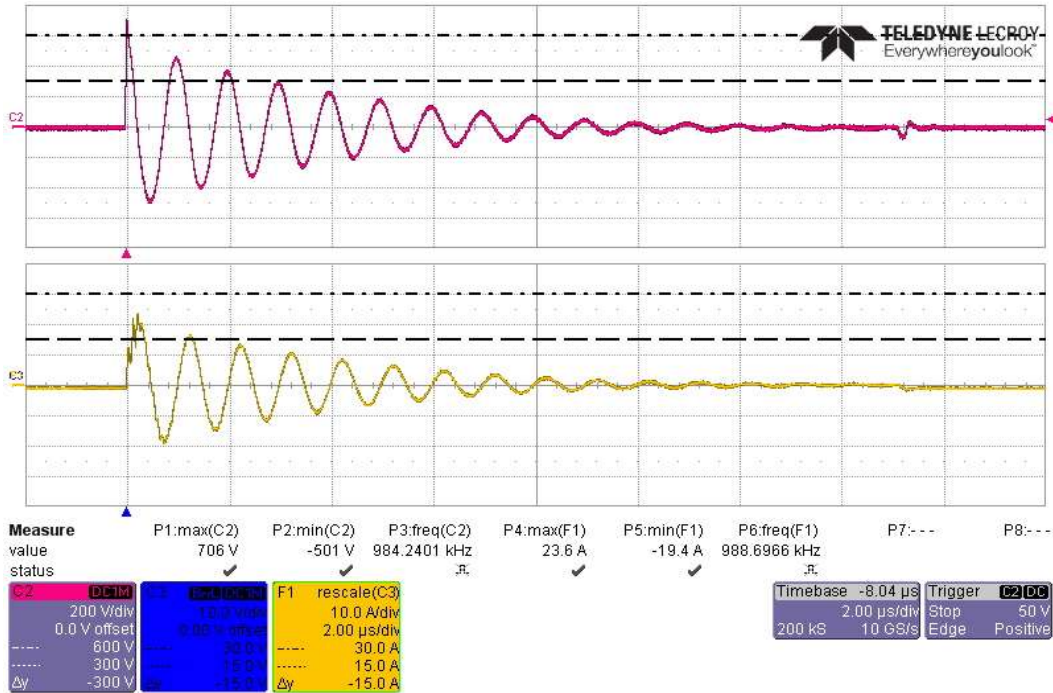

Actual Test CS117 Waveform #3 at 1MHz, First Transient +600V, on Battery Return Side

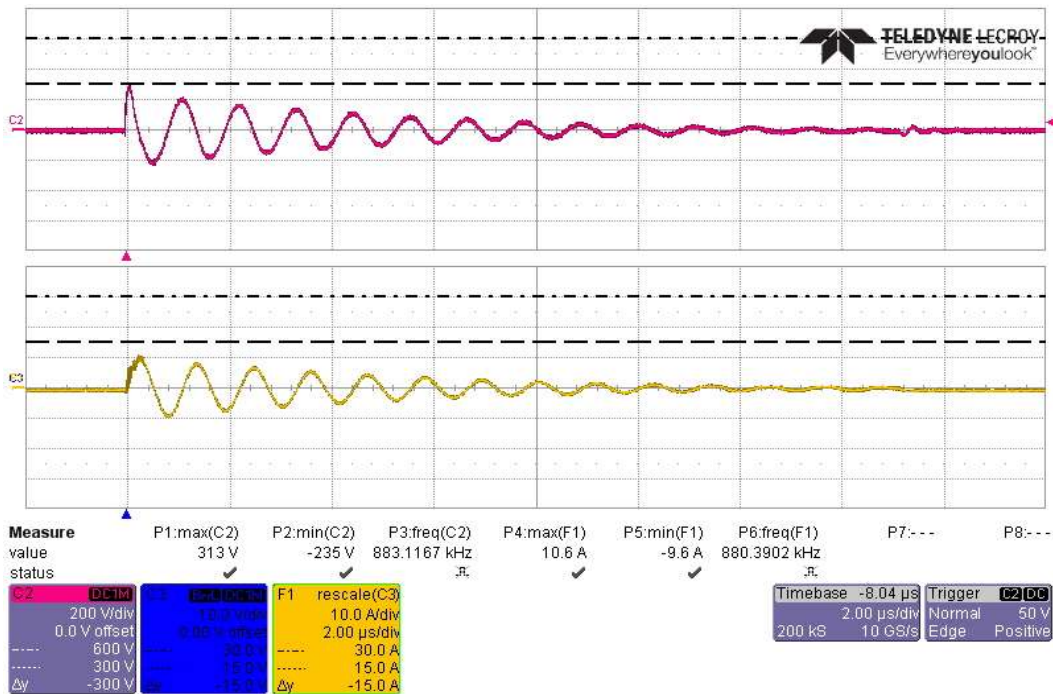

Actual Test CS117 Waveform #3 at 1MHz, Subsequent Transient +300V, on Battery Return Side

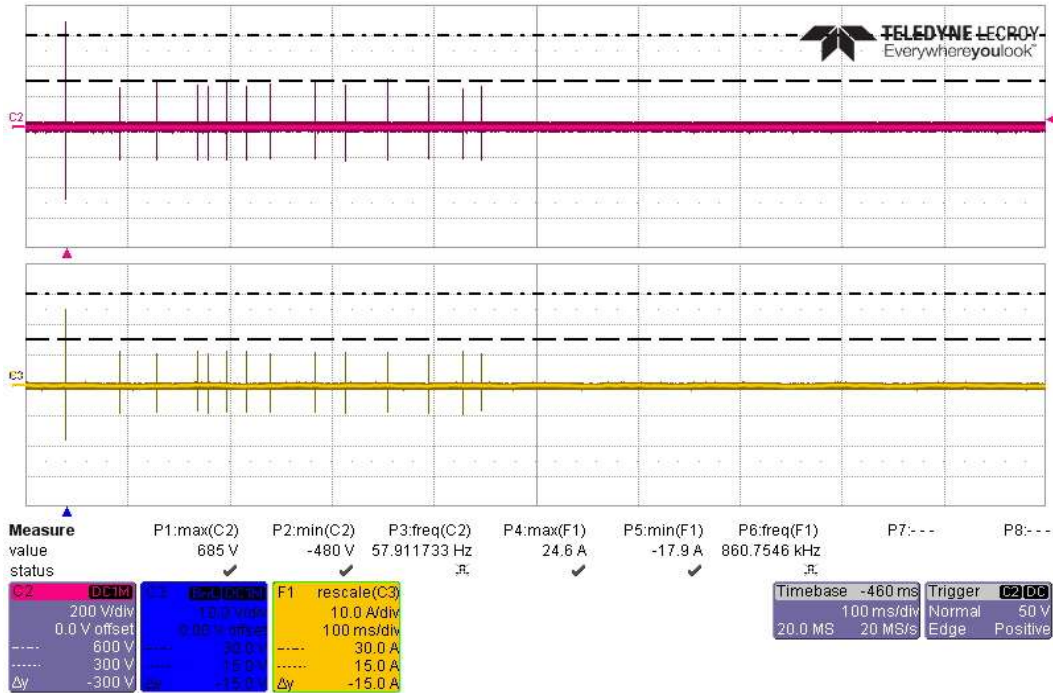

Actual Test CS117 Waveform #3 at 1MHz, 14 Transients +600/+300V, on Battery Return Side

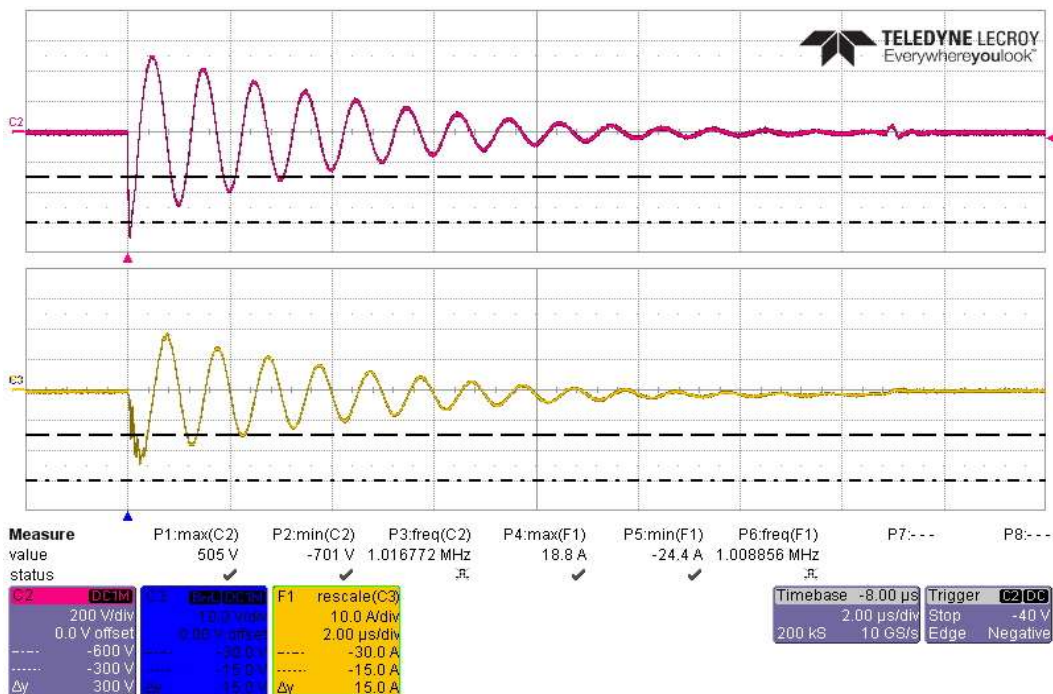

Actual Test CS117 Waveform #3 at 1MHz, First Transient -600V, on Battery Return Side

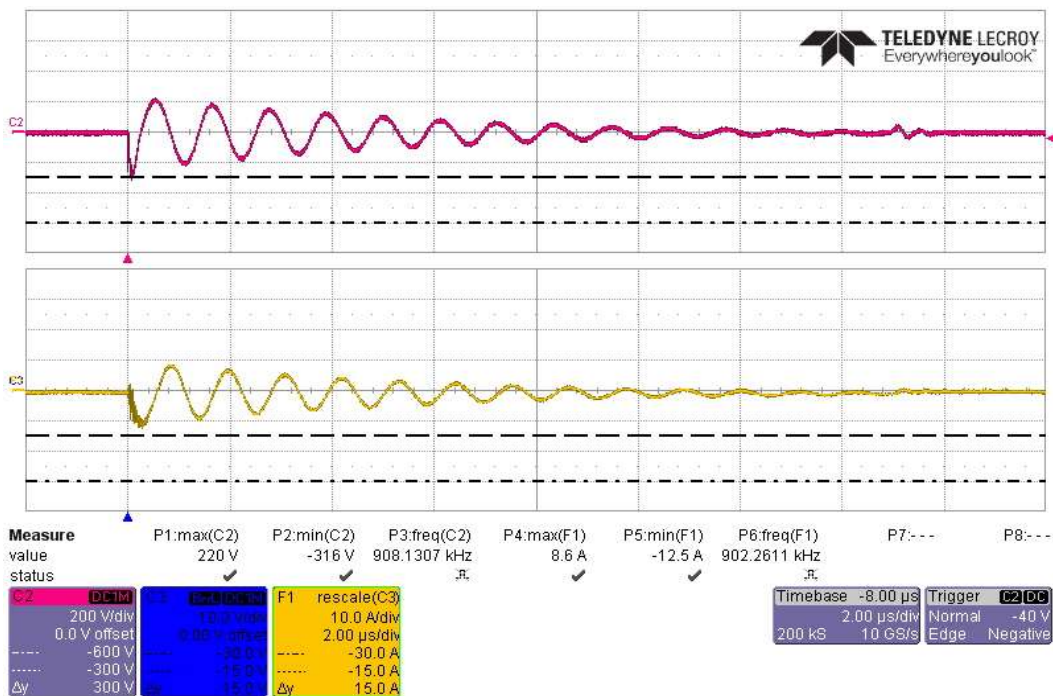

Actual Test CS117 Waveform #3 at 1MHz, Subsequent Transient -300V, on Battery Return Side

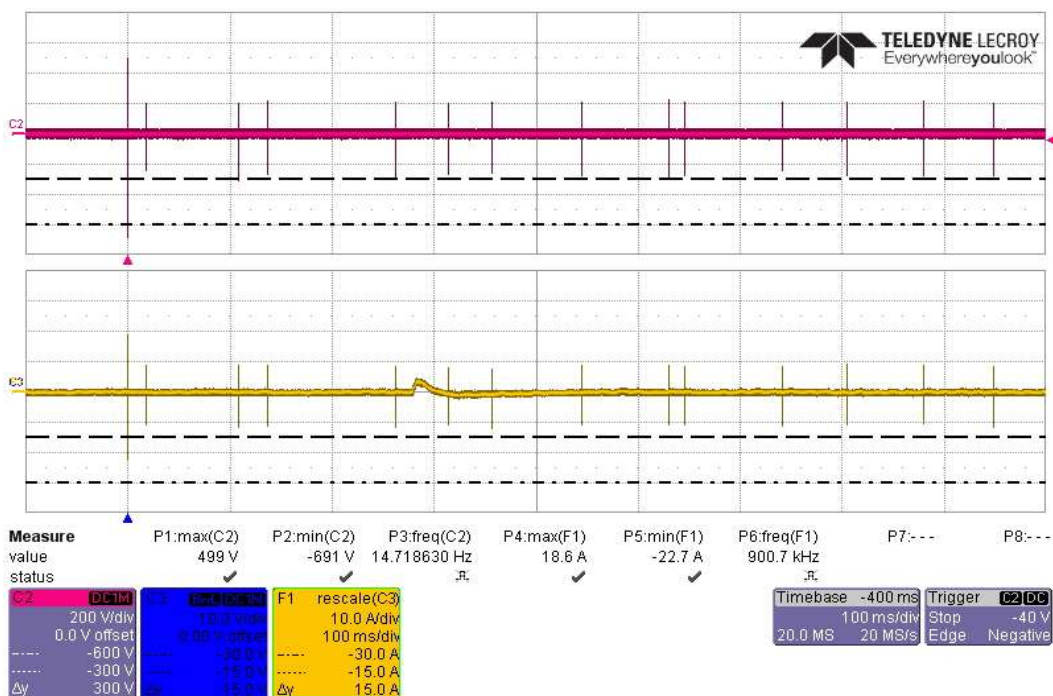

Actual Test CS117 Waveform #3 at 1MHz, 14 Transients -600/-300V, on Battery Return Side

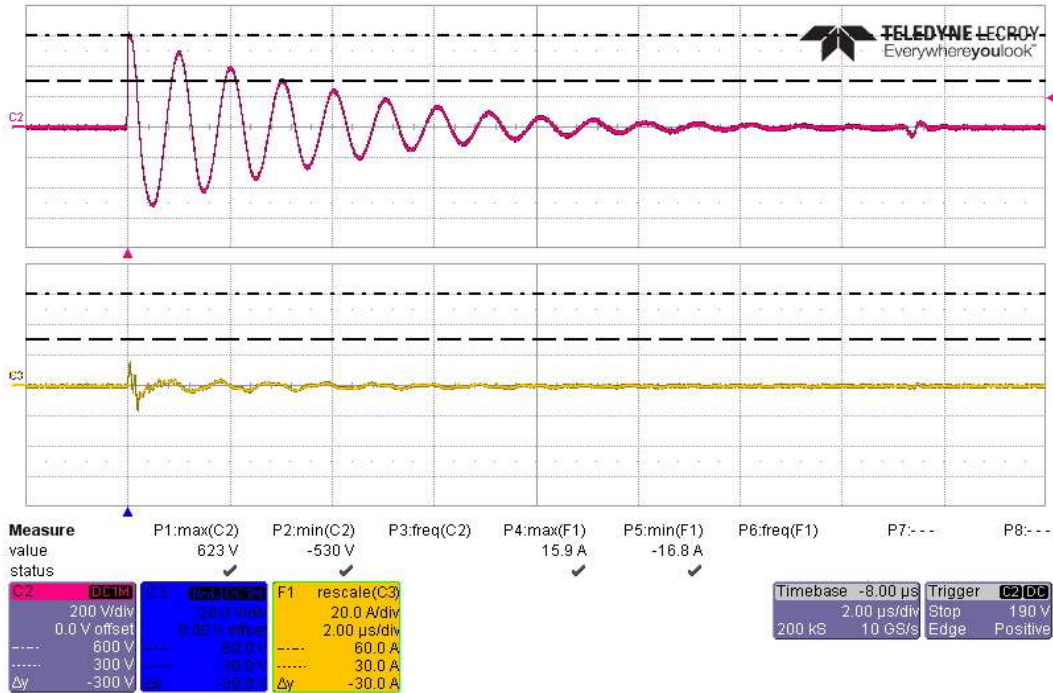

Actual Test CS117 Waveform #3 at 1MHz, First Transient +600V, on Battery Bundle

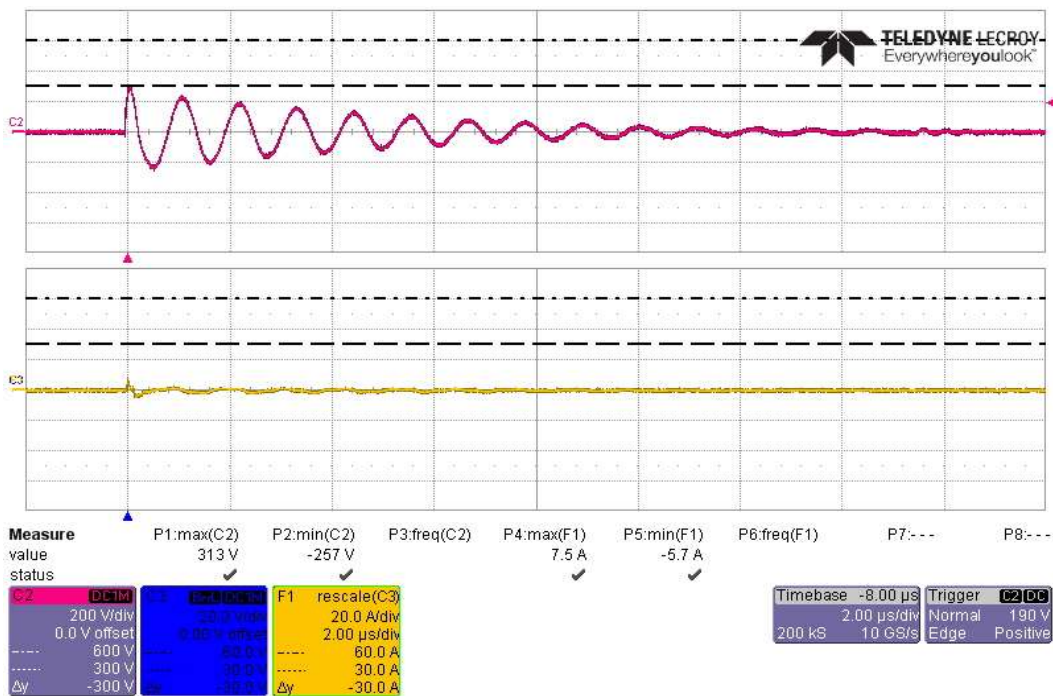

Actual Test CS117 Waveform #3 at 1MHz, Subsequent Transient +300V, on Battery Bundle

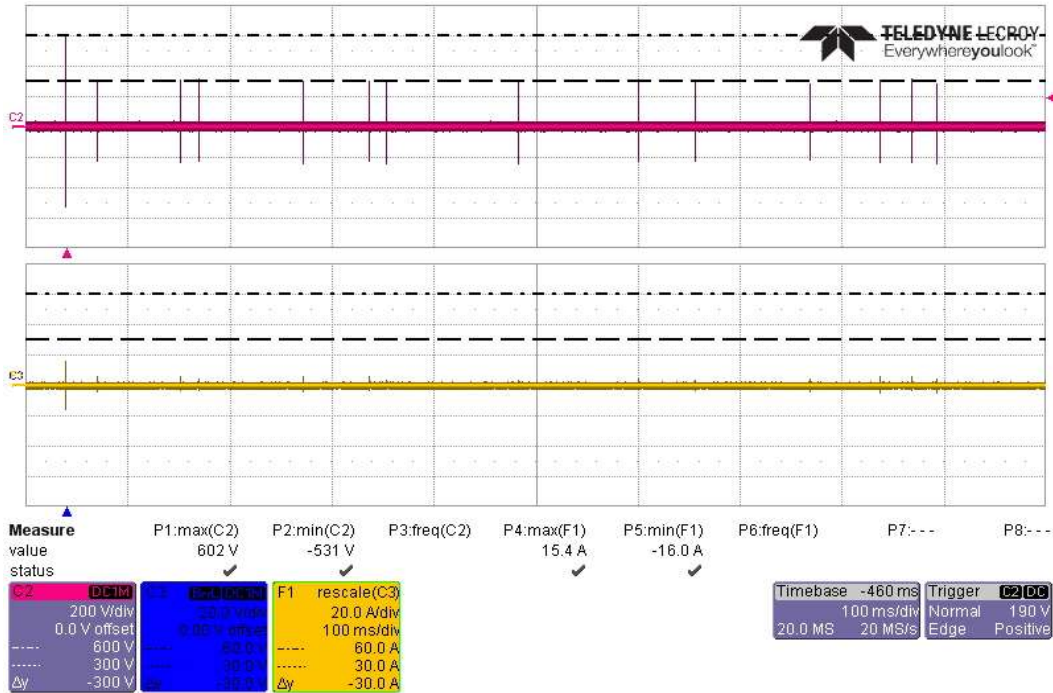

Actual Test CS117 Waveform #3 at 1MHz, 14 Transients +600/+300V, on Battery Bundle

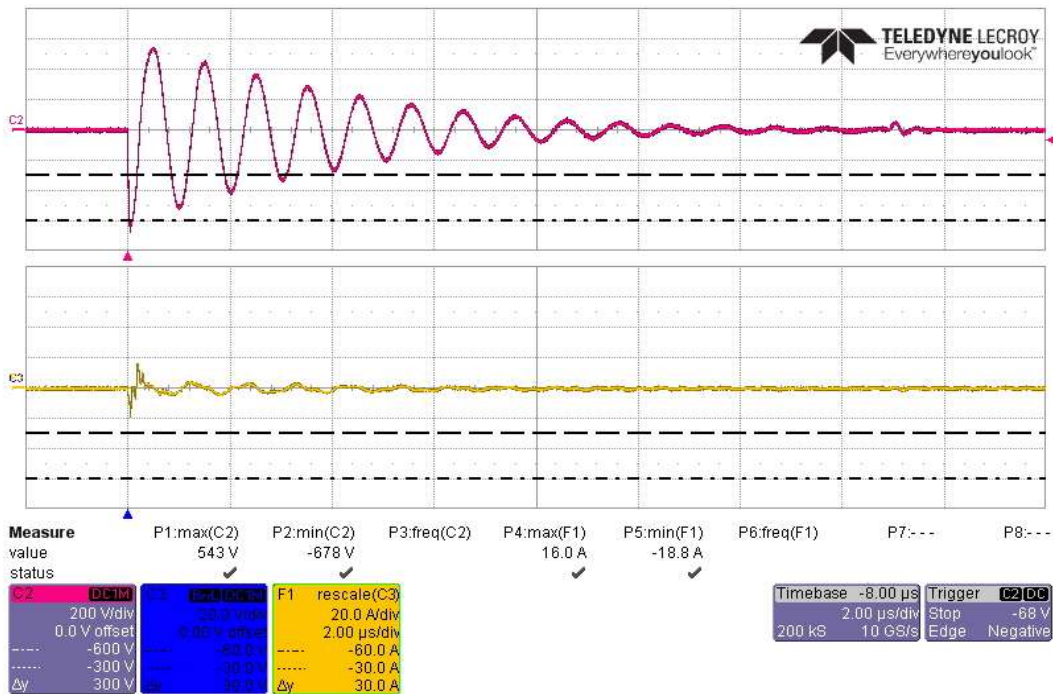

Actual Test CS117 Waveform #3 at 1MHz, First Transient -600V, on Battery Bundle

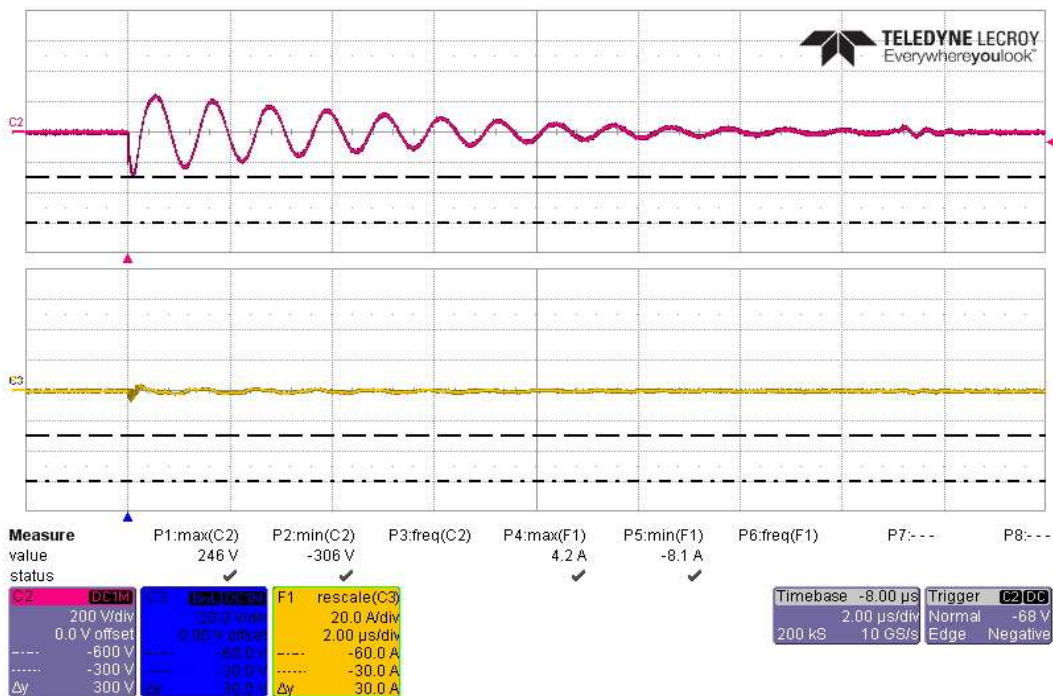

Actual Test CS117 Waveform #3 at 1MHz, Subsequent Transient -300V, on Battery Bundle

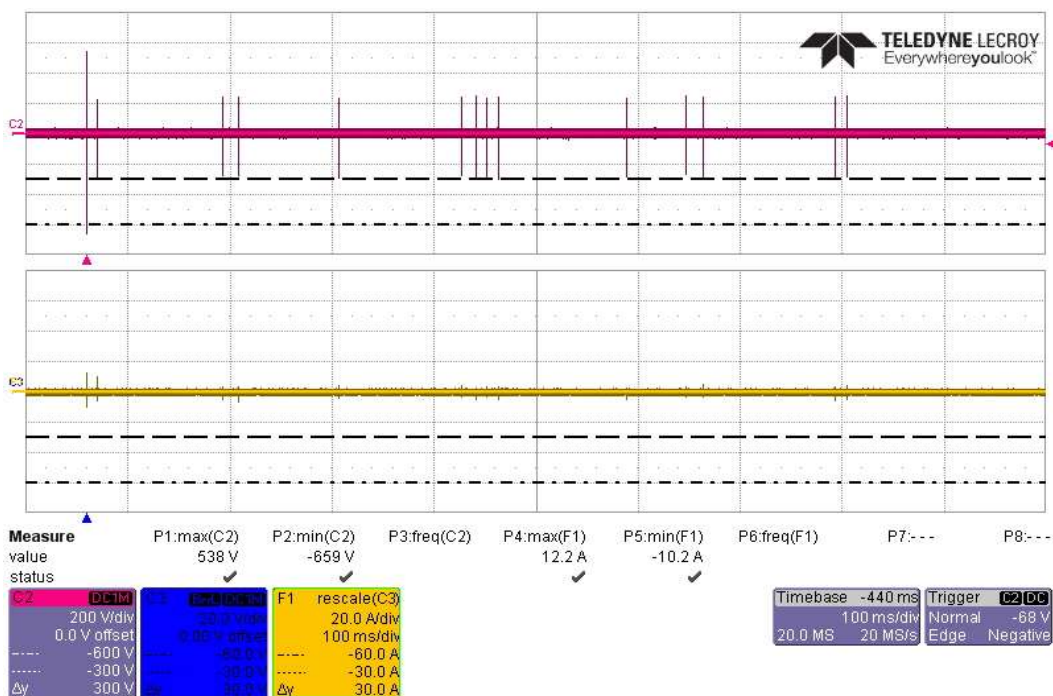

Actual Test CS117 Waveform #3 at 1MHz, 14 Transients -600/-300V, on Battery Bundle

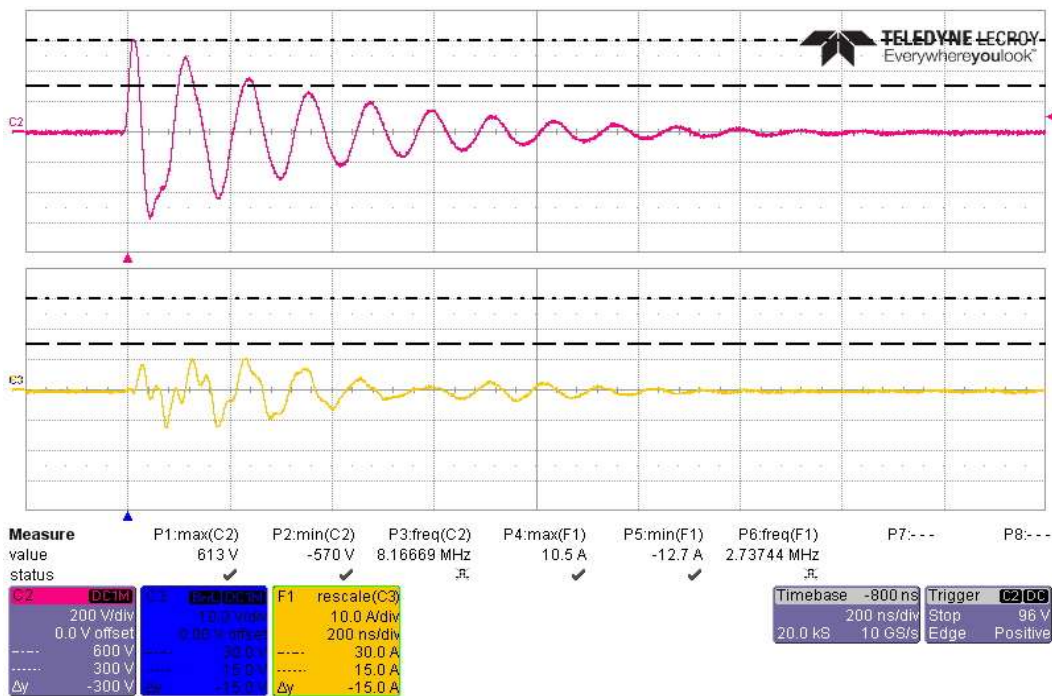
CS117 Actual Test Waveform #3 at 10MHz with 600V/24A

Actual Test CS117 Waveform #3 at 10MHz, First Transient +600V, on Battery High Side

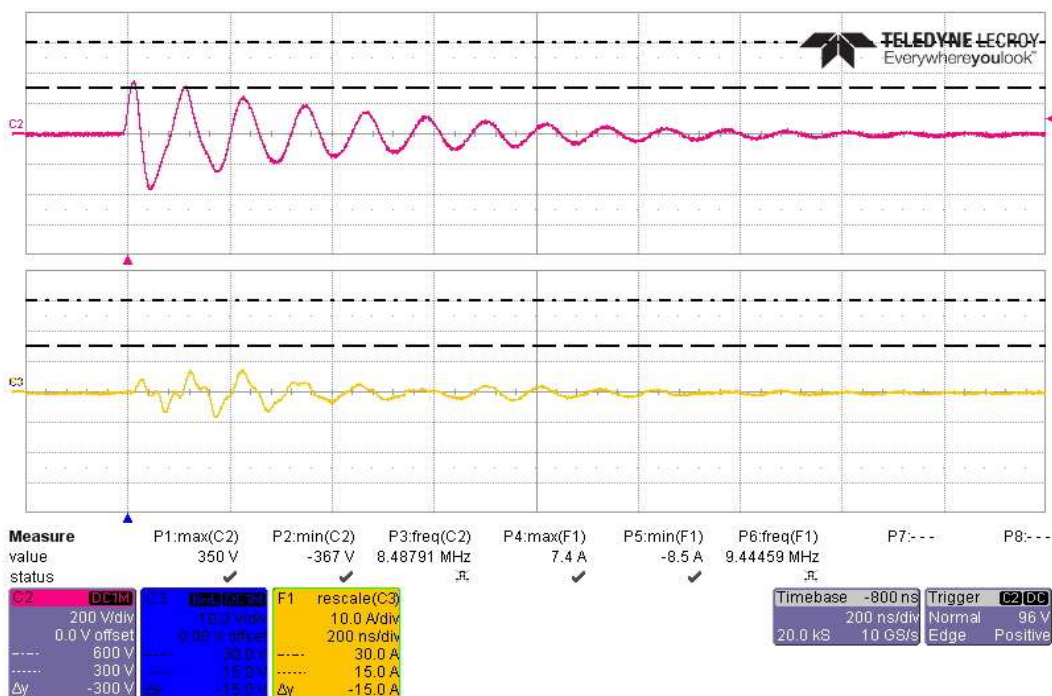

Actual Test CS117 Waveform #3 at 10MHz, Subsequent Transient +300V, on Battery High Side

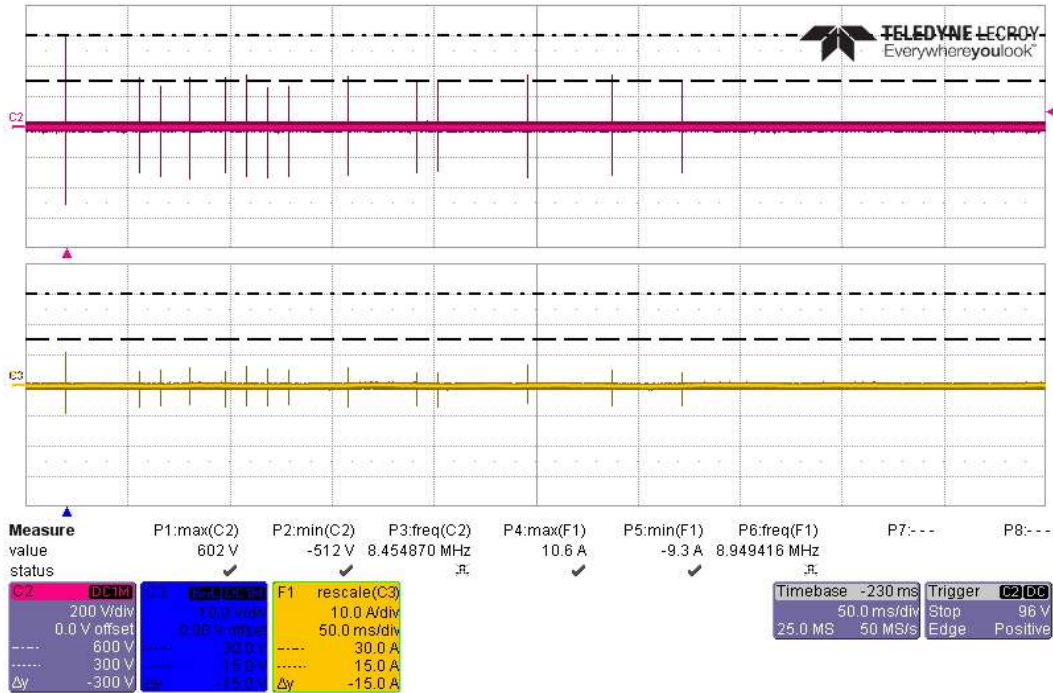

Actual Test CS117 Waveform #3 at 10MHz, 14 Transients +600/+300V, on Battery High Side

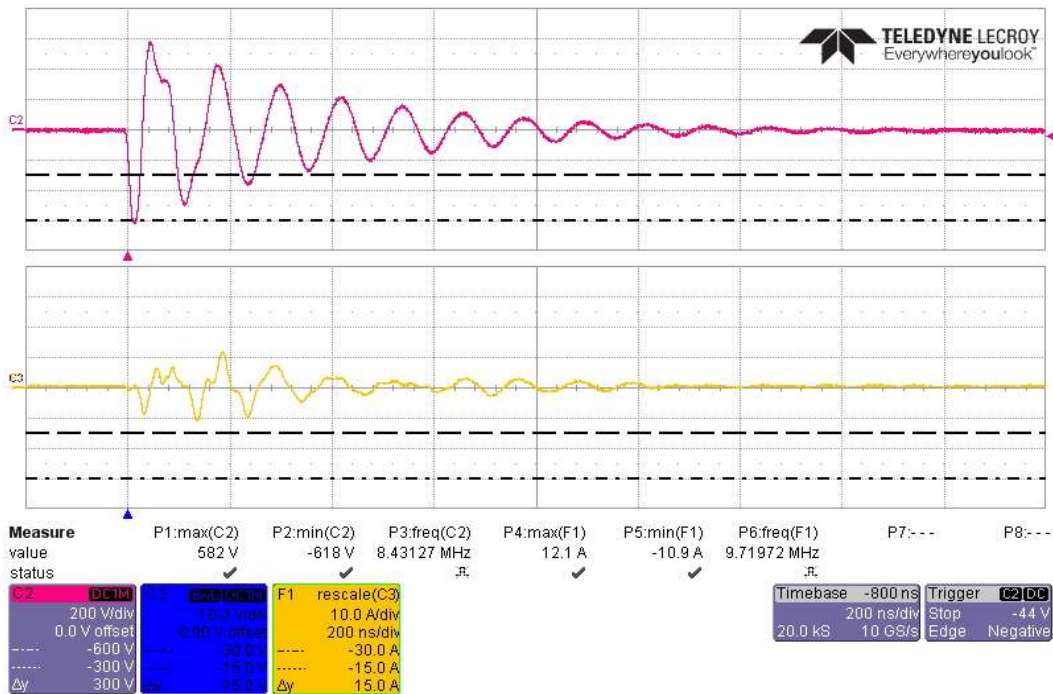

Actual Test CS117 Waveform #3 at 10MHz, First Transient -600V, on Battery High Side

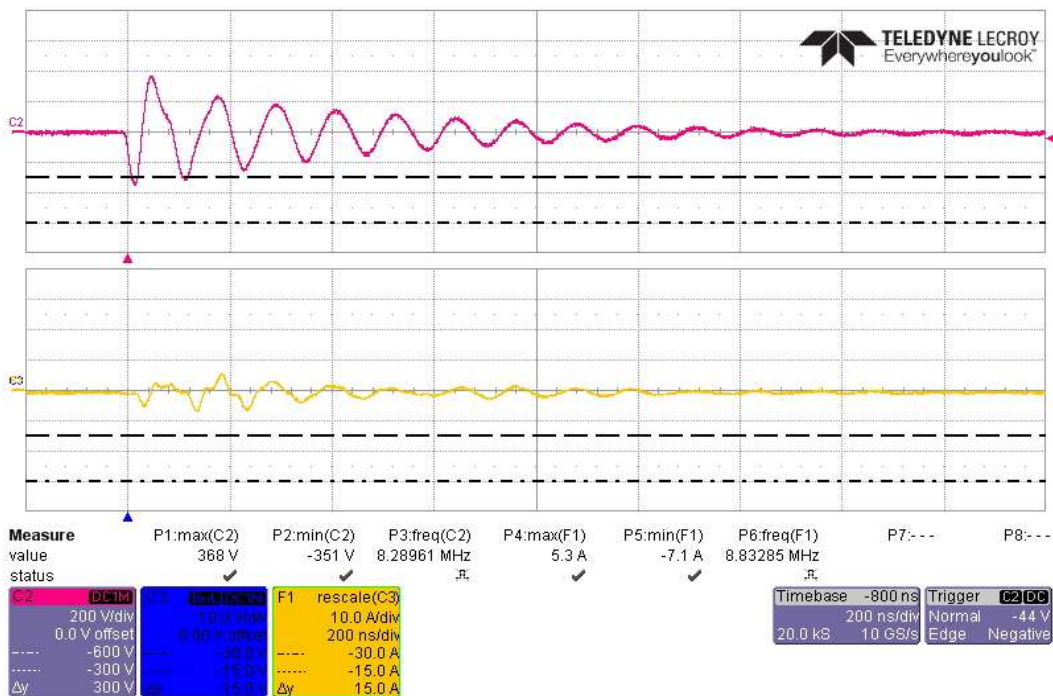

Actual Test CS117 Waveform #3 at 10MHz, Subsequent Transient -300V, on Battery High Side

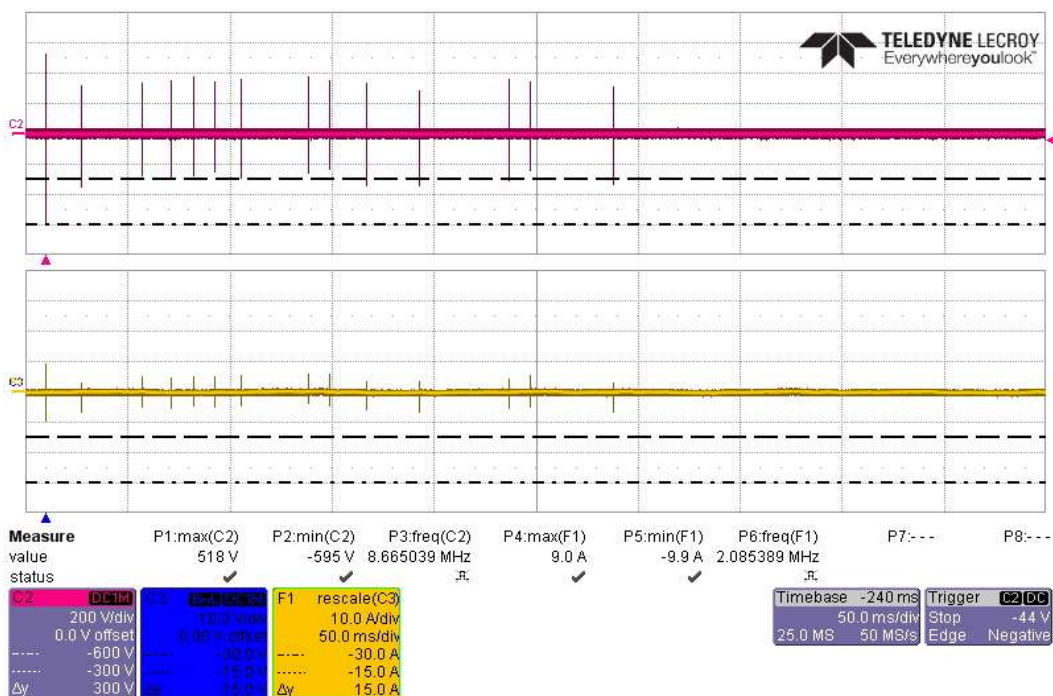

Actual Test CS117 Waveform #3 at 10MHz, 14 Transients -600/-300V, on Battery High Side

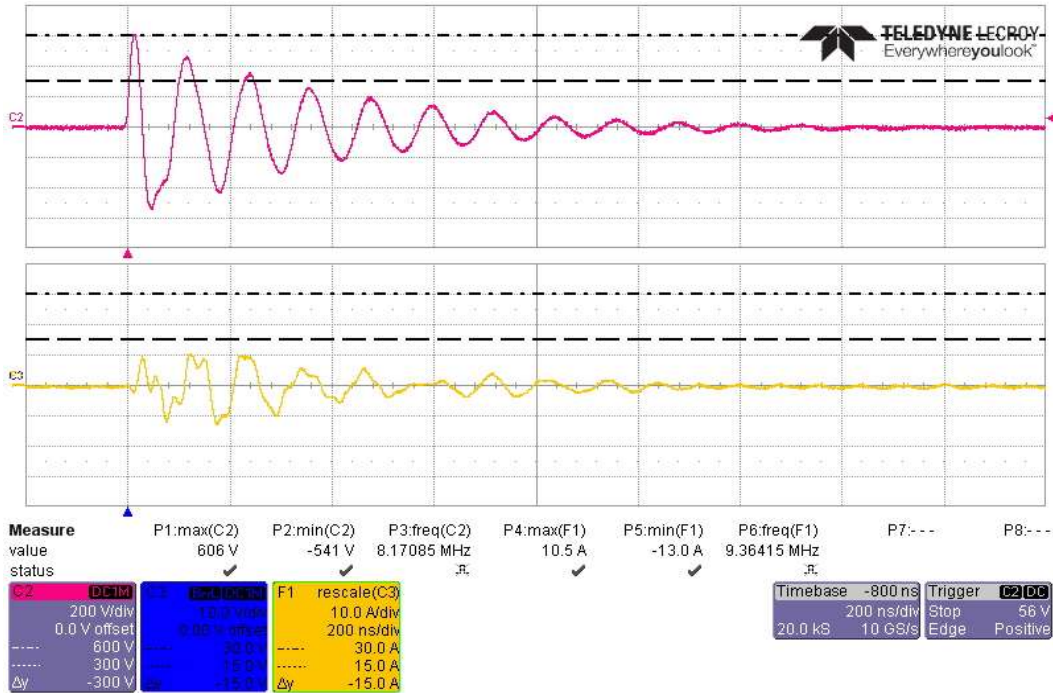

Actual Test CS117 Waveform #3 at 10MHz, First Transient +600V, on Battery Return Side

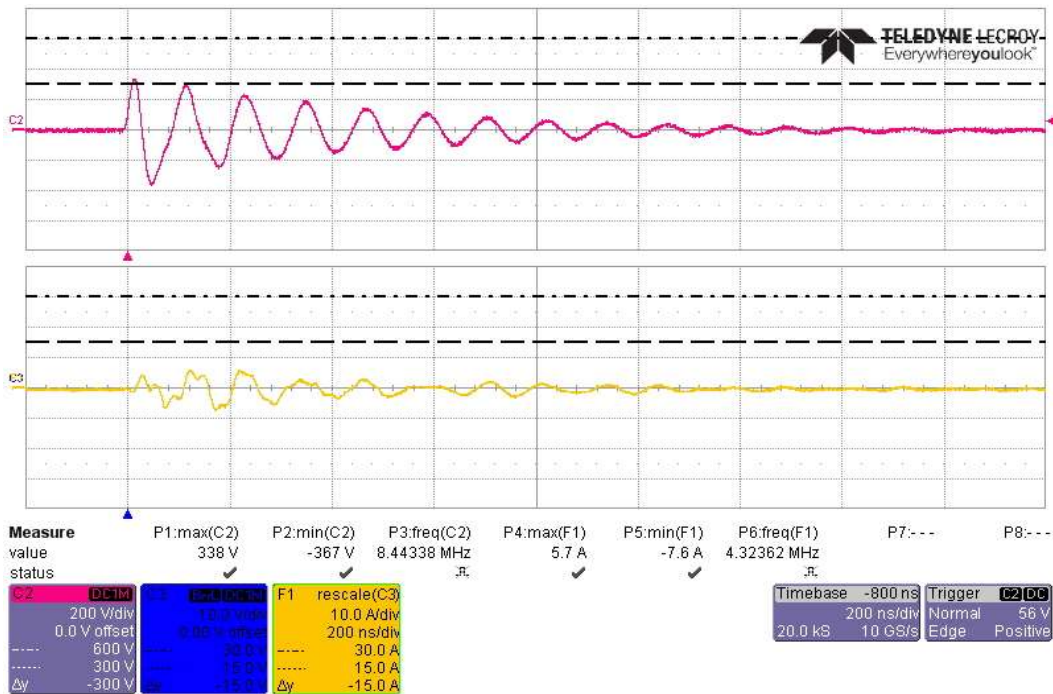

Actual Test CS117 Waveform #3 at 10MHz, Subsequent Transient +300V, on Battery Return Side

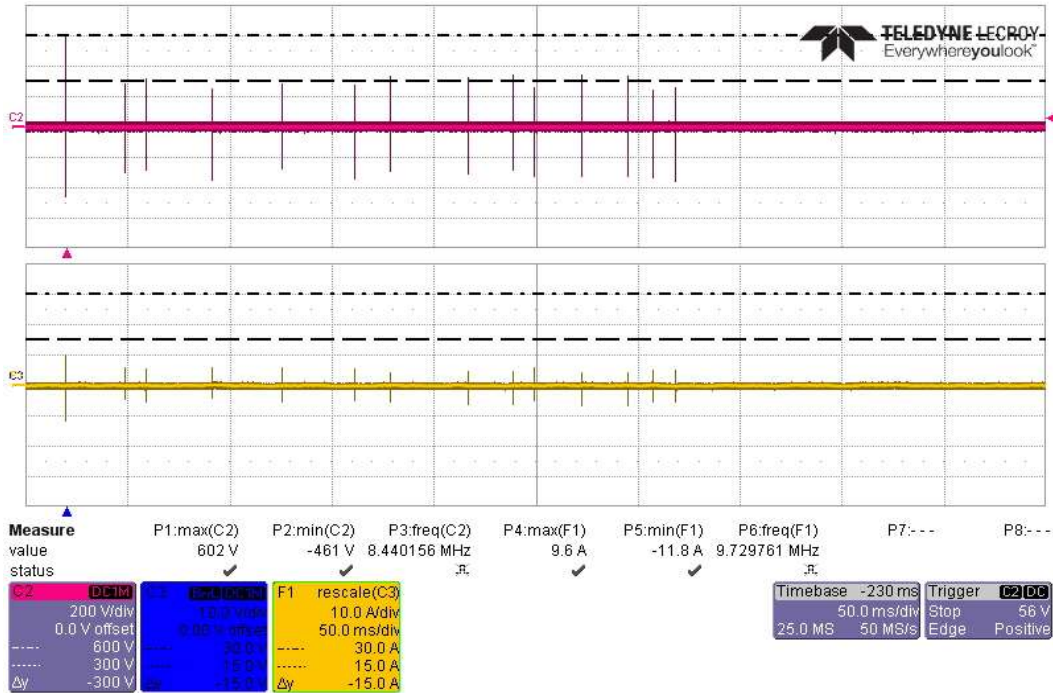

Actual Test CS117 Waveform #3 at 10MHz, 14 Transients +600/+300V, on Battery Return Side

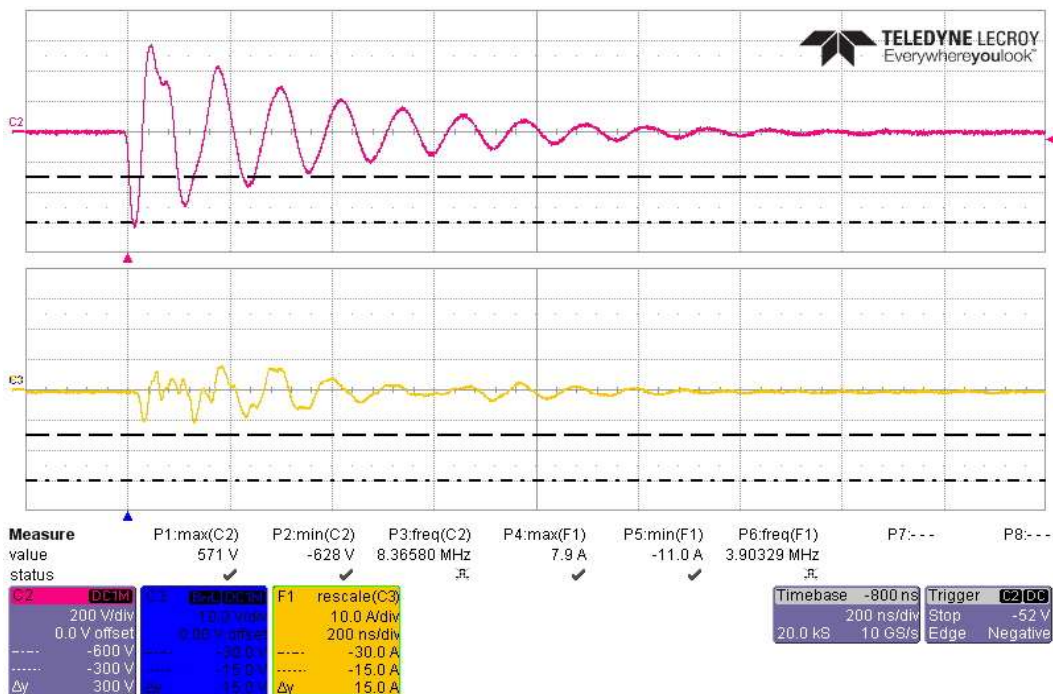

Actual Test CS117 Waveform #3 at 10MHz, First Transient -600V, on Battery Return Side

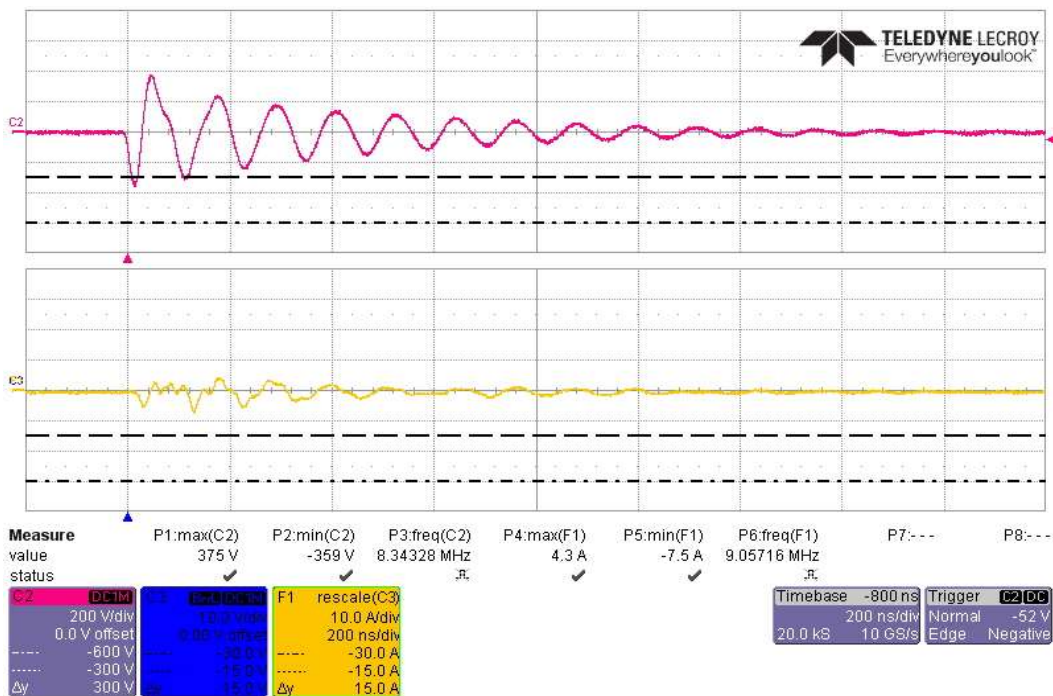

Actual Test CS117 Waveform #3 at 10MHz, Subsequent Transient -300V, on Battery Return Side

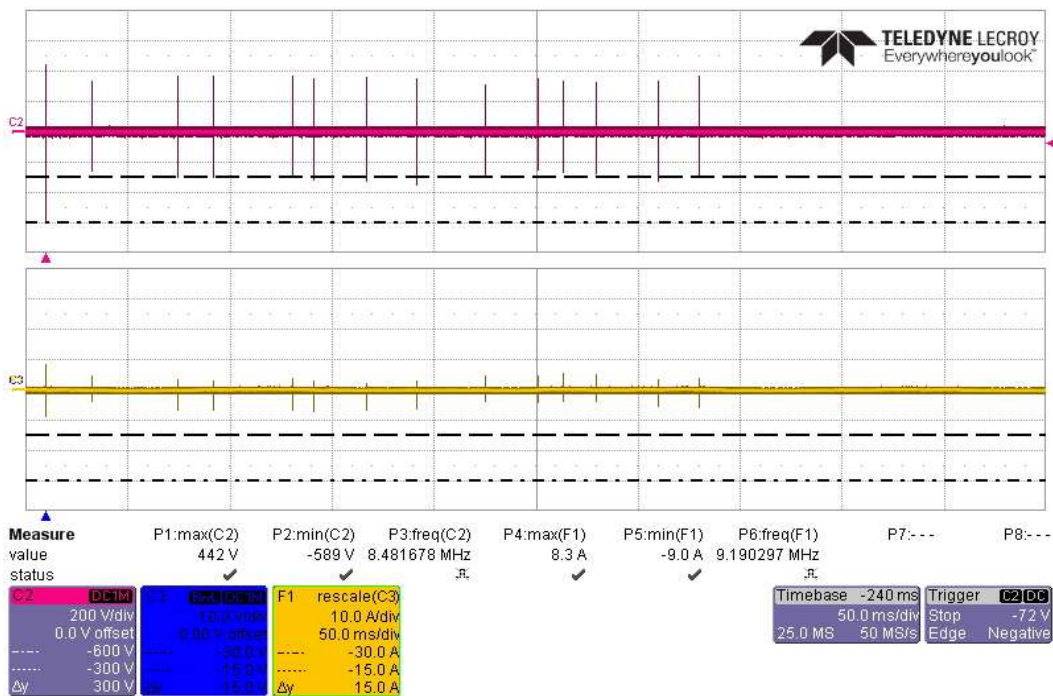

Actual Test CS117 Waveform #3 at 10MHz, 14 Transients -600/300V, on Battery Return Side

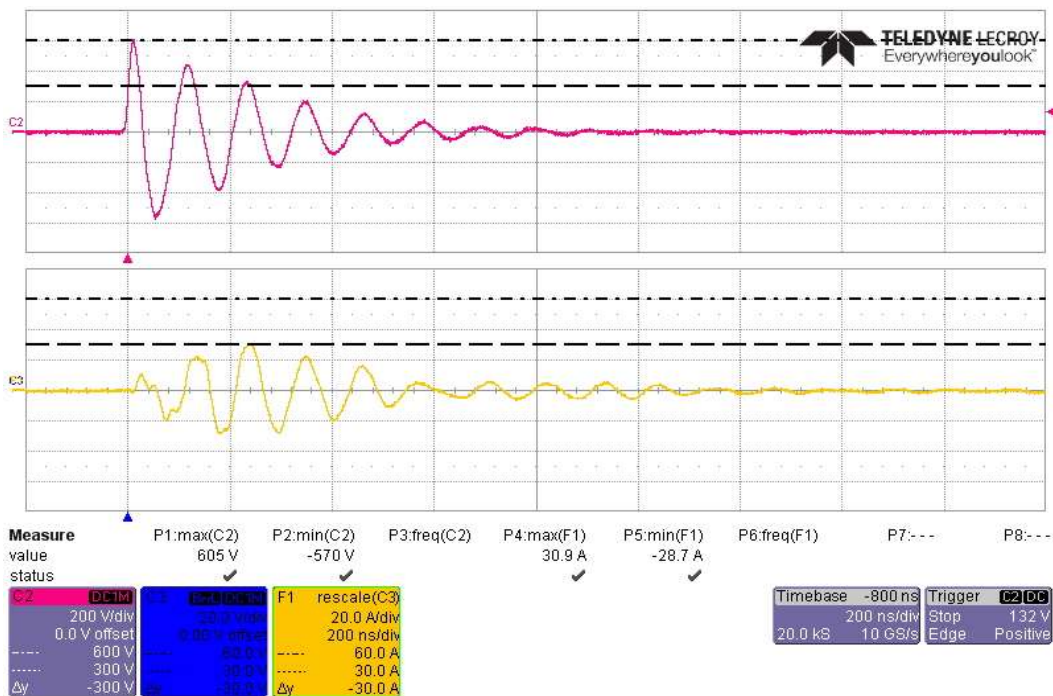

Actual Test CS117 Waveform #3 at 10MHz, First Transient +600V, on Battery Bundle

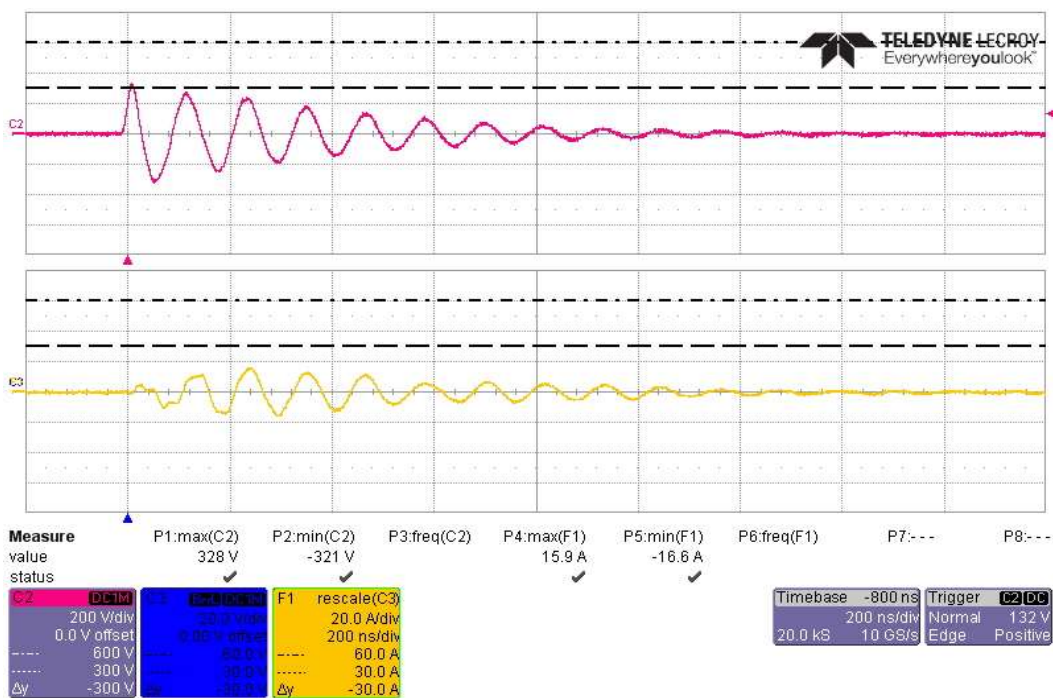

Actual Test CS117 Waveform #3 at 10MHz, Subsequent Transient +300V, on Battery Bundle

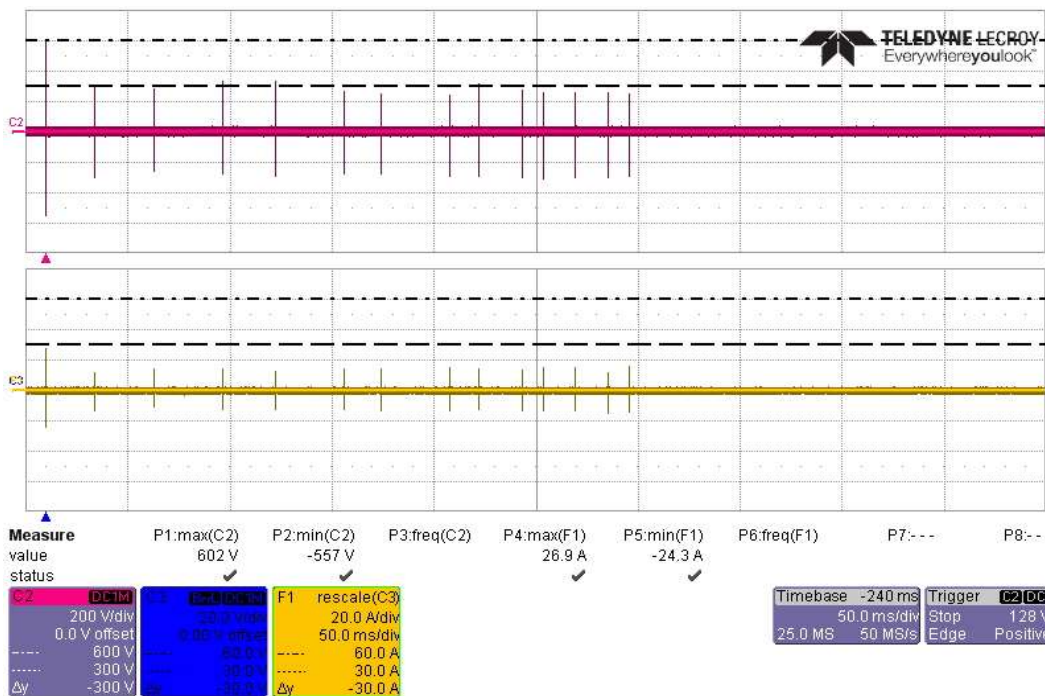

Actual Test CS117 Waveform #3 at 10MHz, 14 Transients +600/+300V, on Battery Bundle

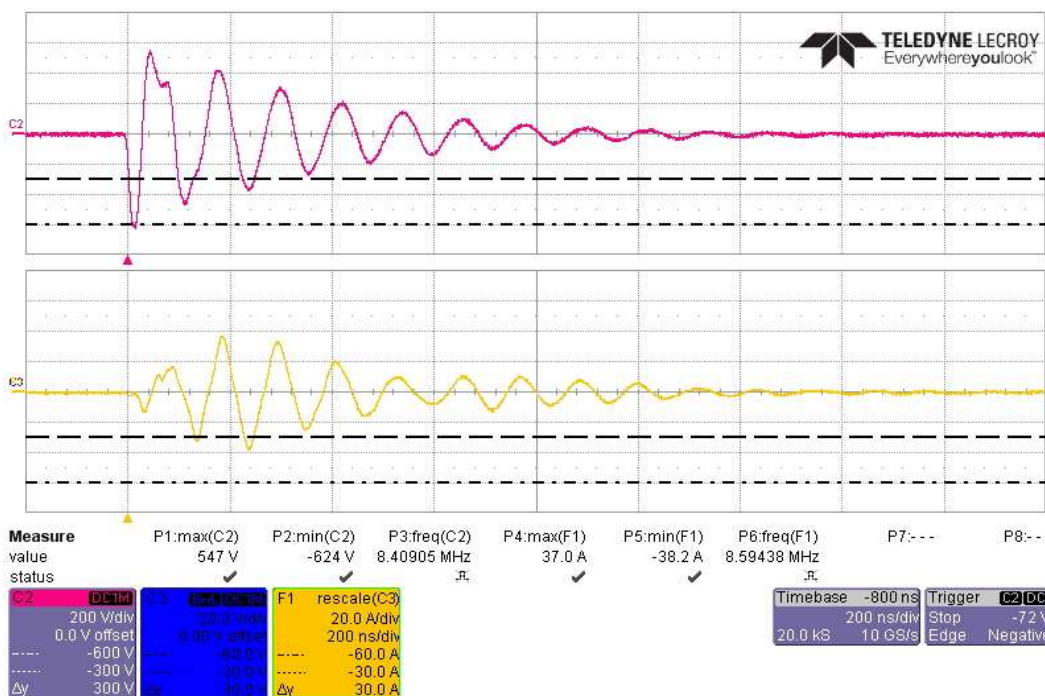

Actual Test CS117 Waveform #3 at 10MHz, First Transient -600V, on Battery Bundle

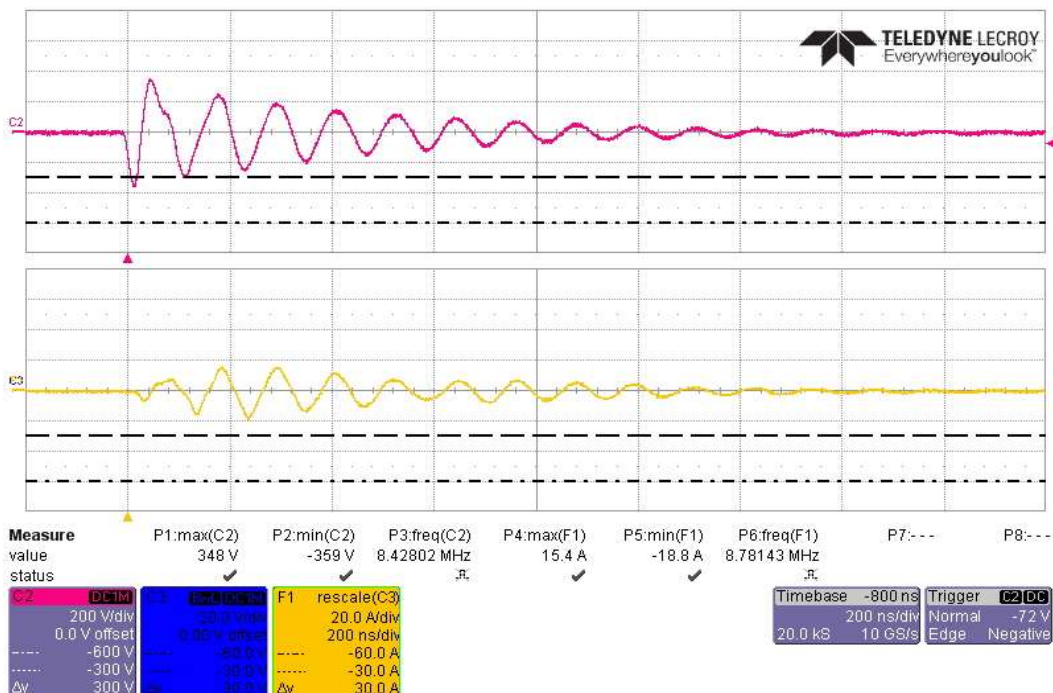

Actual Test CS117 Waveform #3 at 10MHz, Subsequent Transient -300V, on Battery Bundle

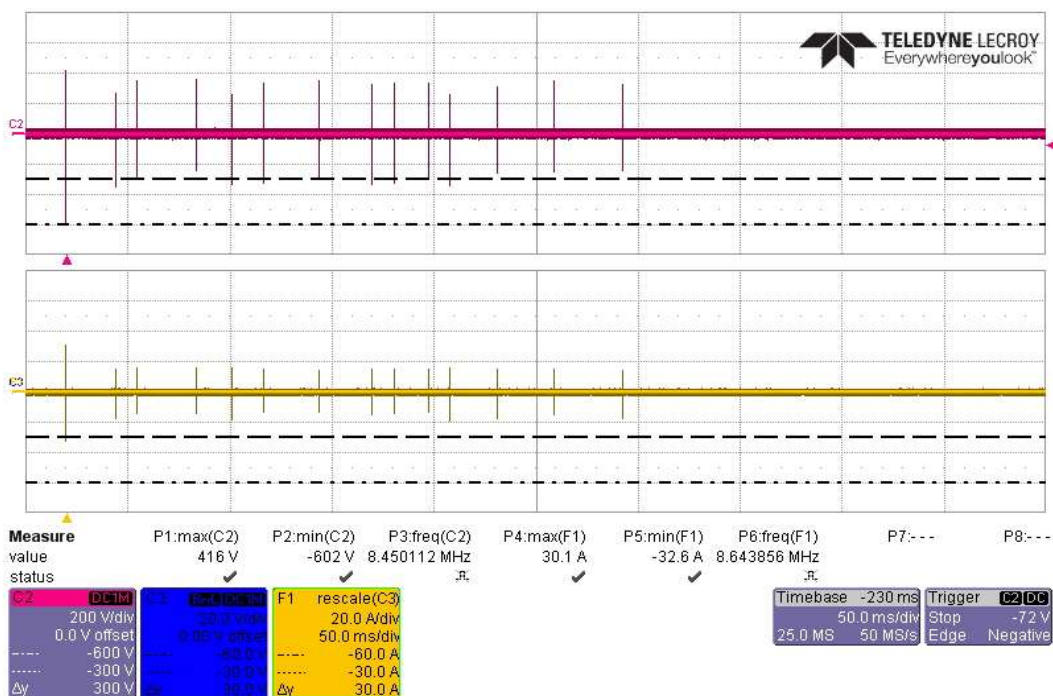

Actual Test CS117 Waveform #3 at 10MHz, 14 Transients -600/-300V, on Battery Bundle

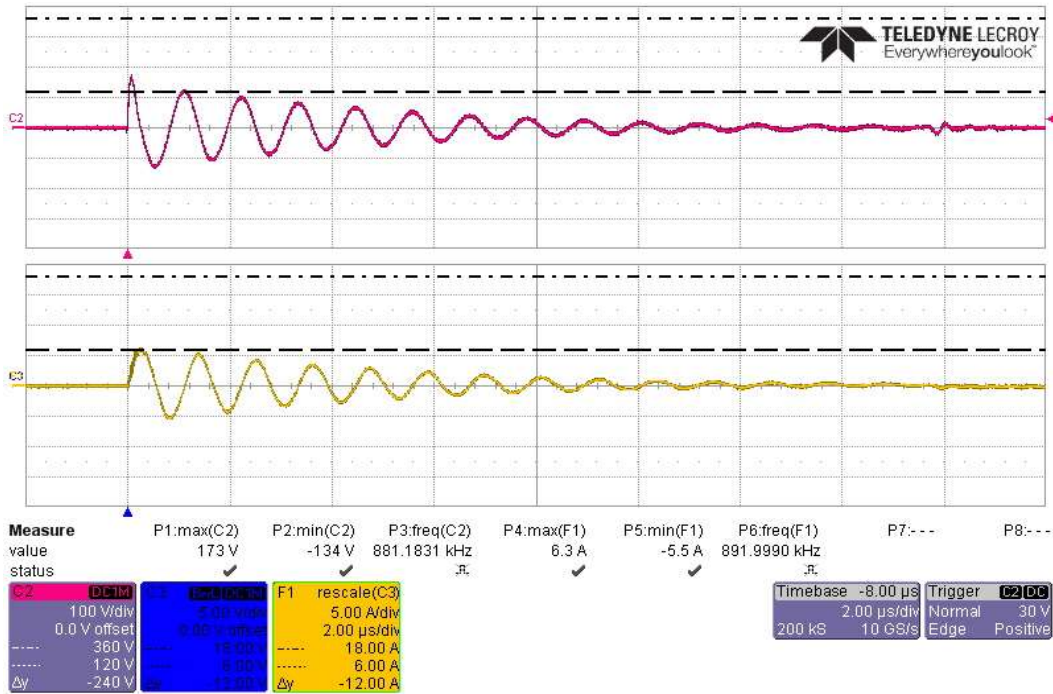
CS117 Actual Test Multiple Burst Waveform #3 at 1MHz with 360V/6A

Actual Test CS117 Waveform #3 at 1MHz, First Transient +360V/6A, on Battery High Side

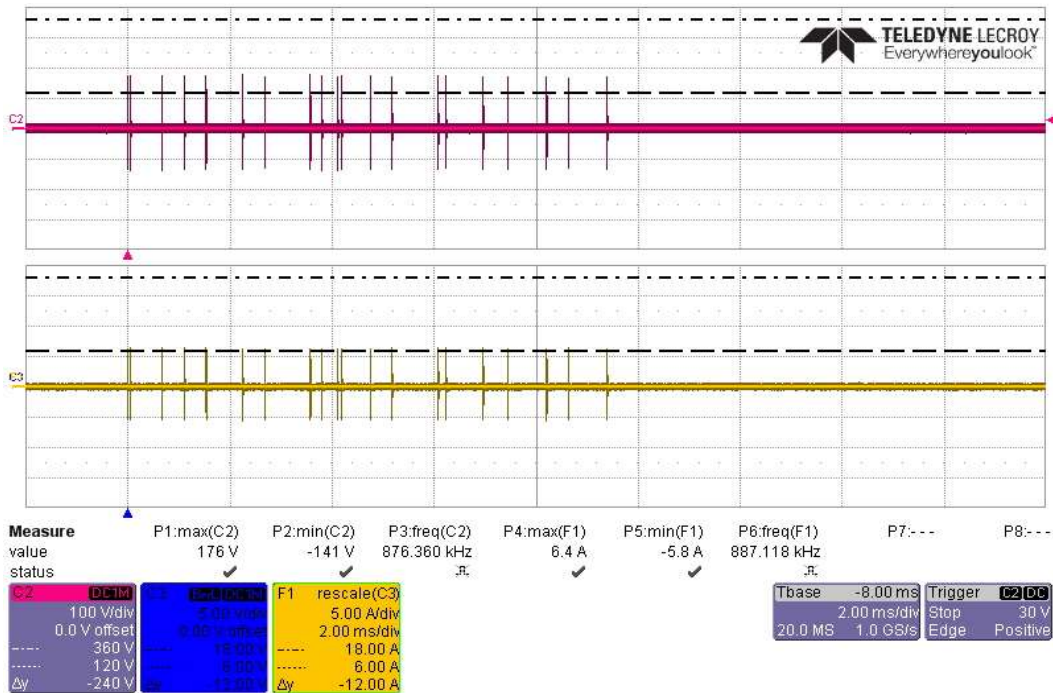

Actual Test CS117 Waveform #3 at 1MHz, 20 Transients +360V/6A, on Battery High Side

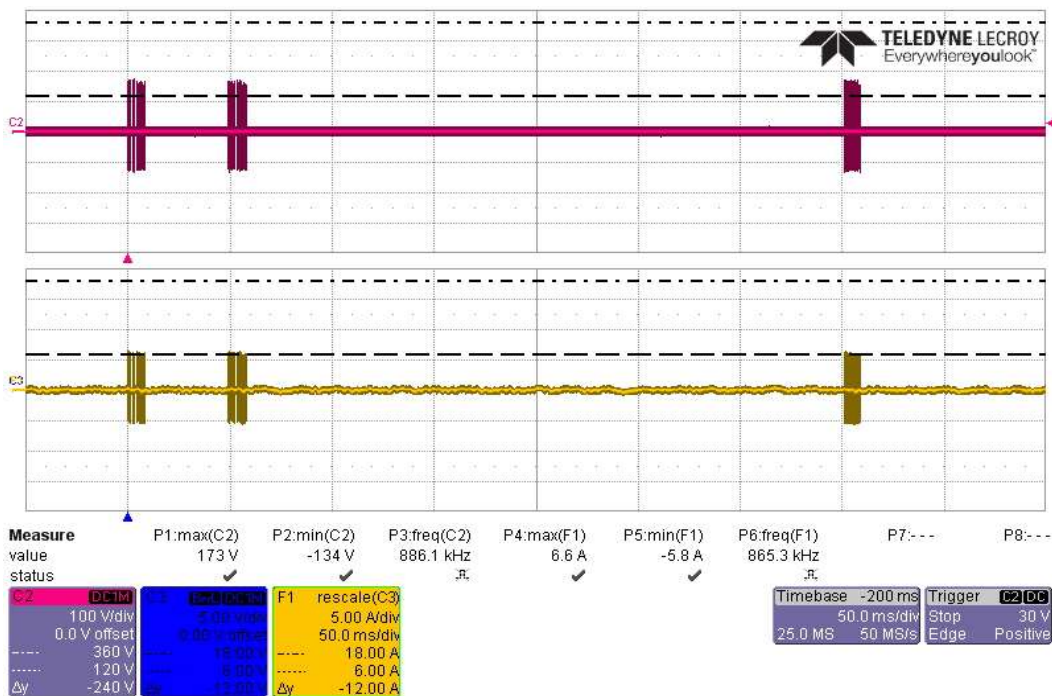

Actual Test CS117 Waveform #3 at 1MHz, 3 Bursts +360V/6A, on Battery High Side

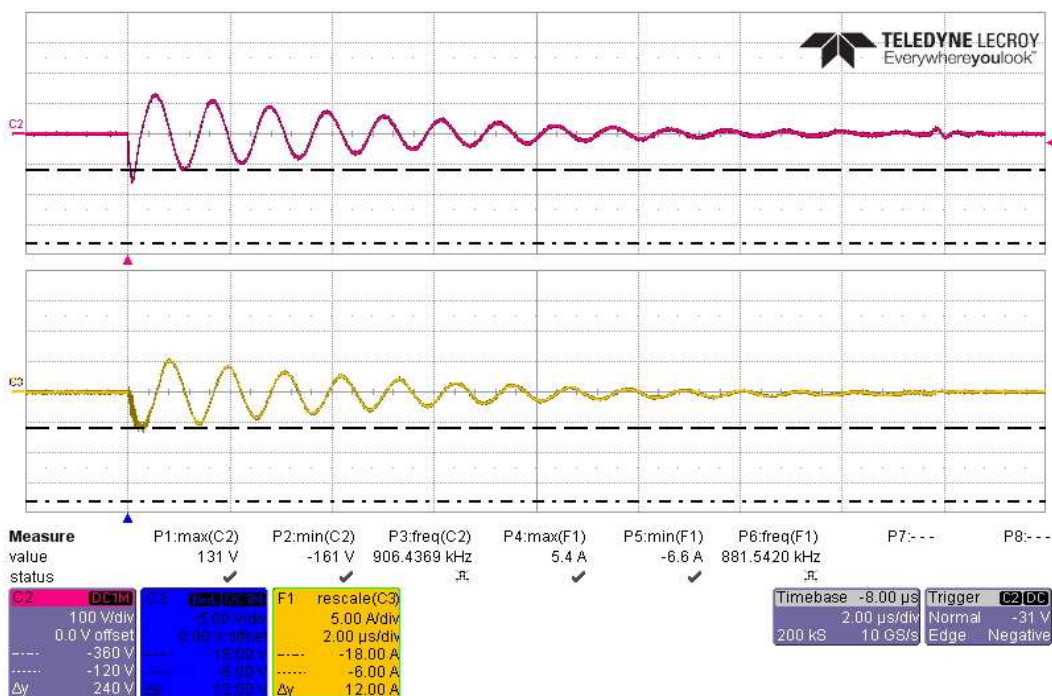

Actual Test CS117 Waveform #3 at 1MHz, First Transient -360V/6A, on Battery High Side

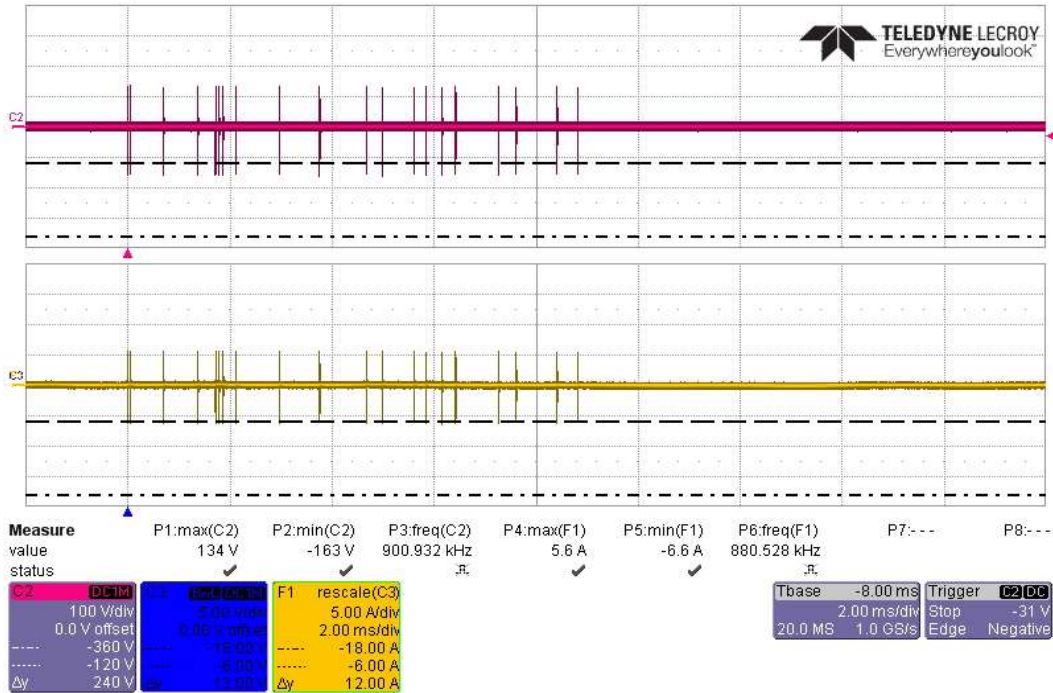

Actual Test CS117 Waveform #3 at 1MHz, 20 Transients -360V/6A, on Battery High Side

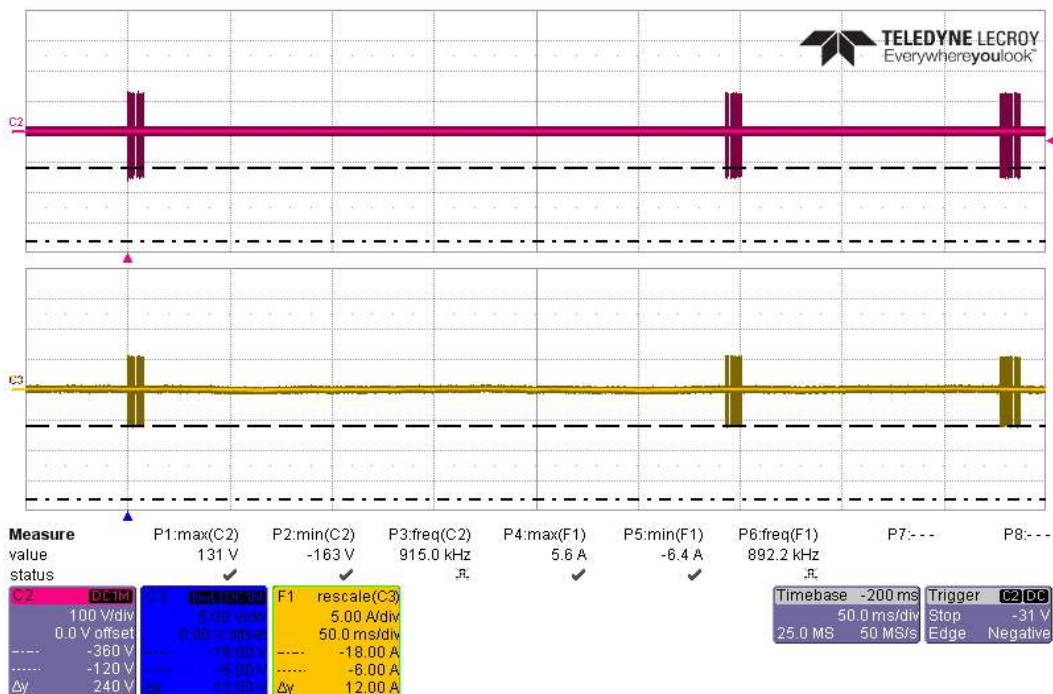

Actual Test CS117 Waveform #3 at 1MHz, 3 Bursts -360V/6A, on Battery High Side

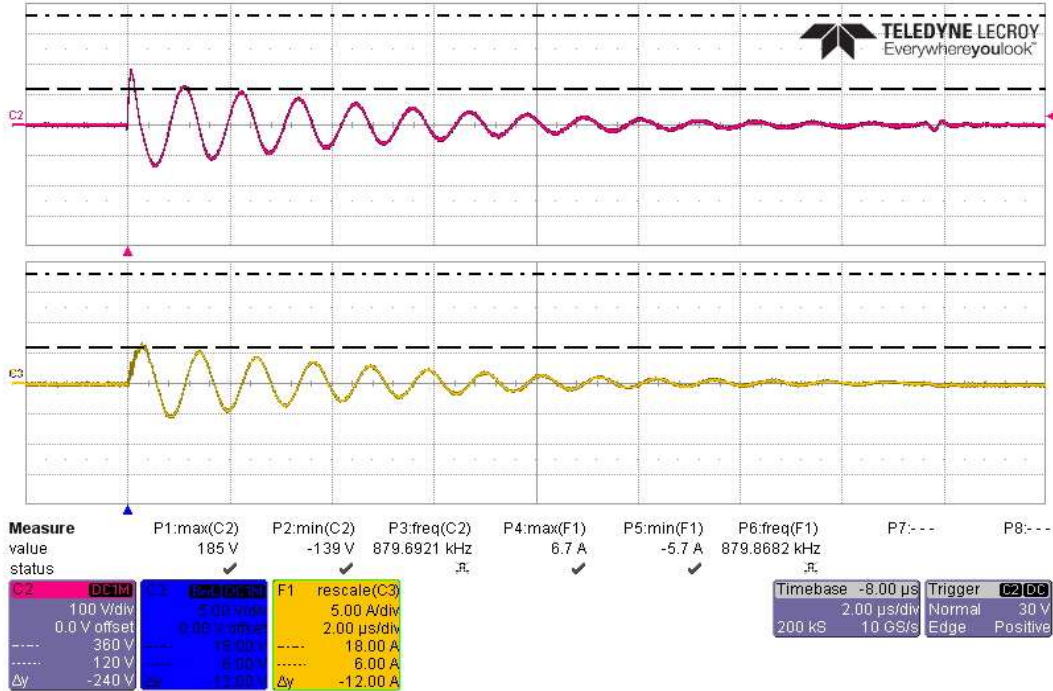

Actual Test CS117 Waveform #3 at 1MHz, First Transient +360V/6A, on Battery Return Side

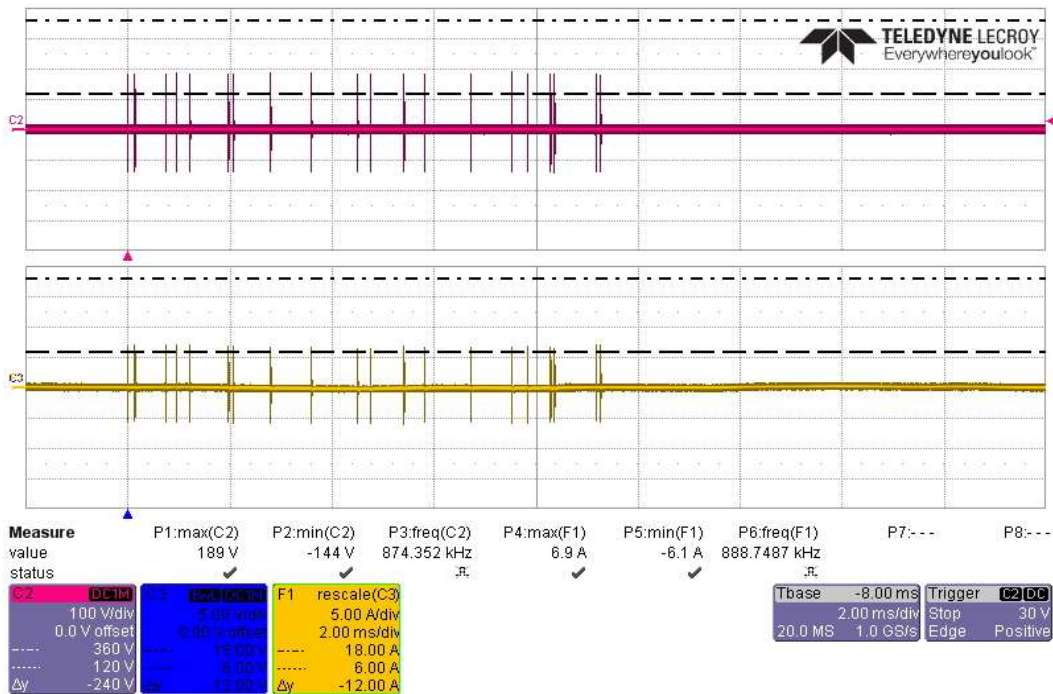

Actual Test CS117 Waveform #3 at 1MHz, 20 Transients +360V/6A, on Battery Return Side

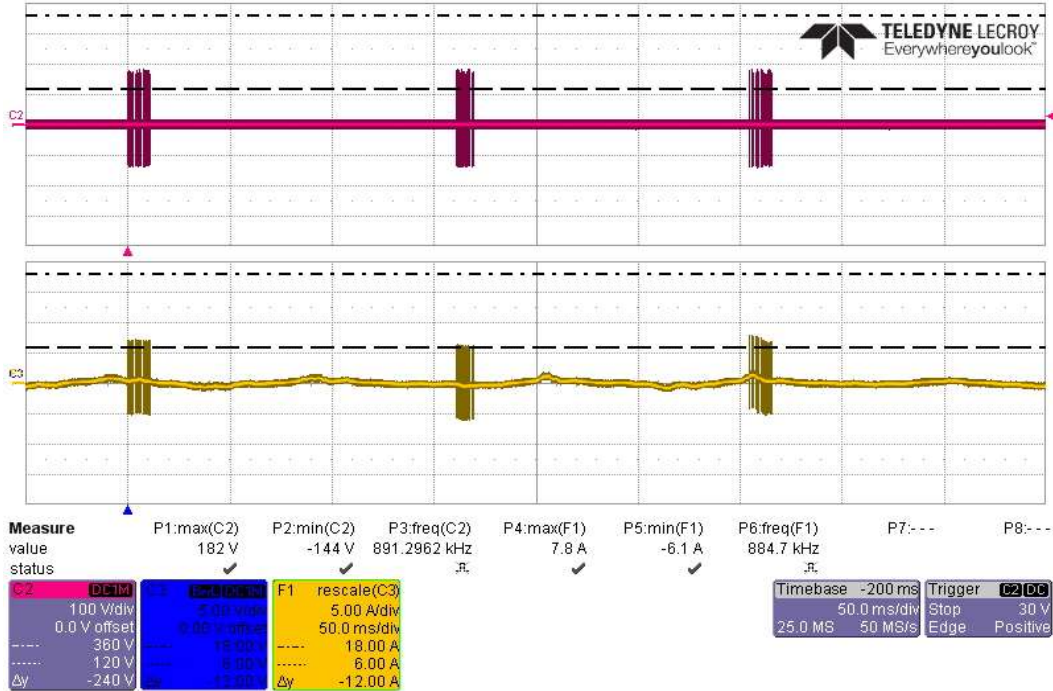

Actual Test CS117 Waveform #3 at 1MHz, 3 Bursts +360V/6A, on Battery Return Side

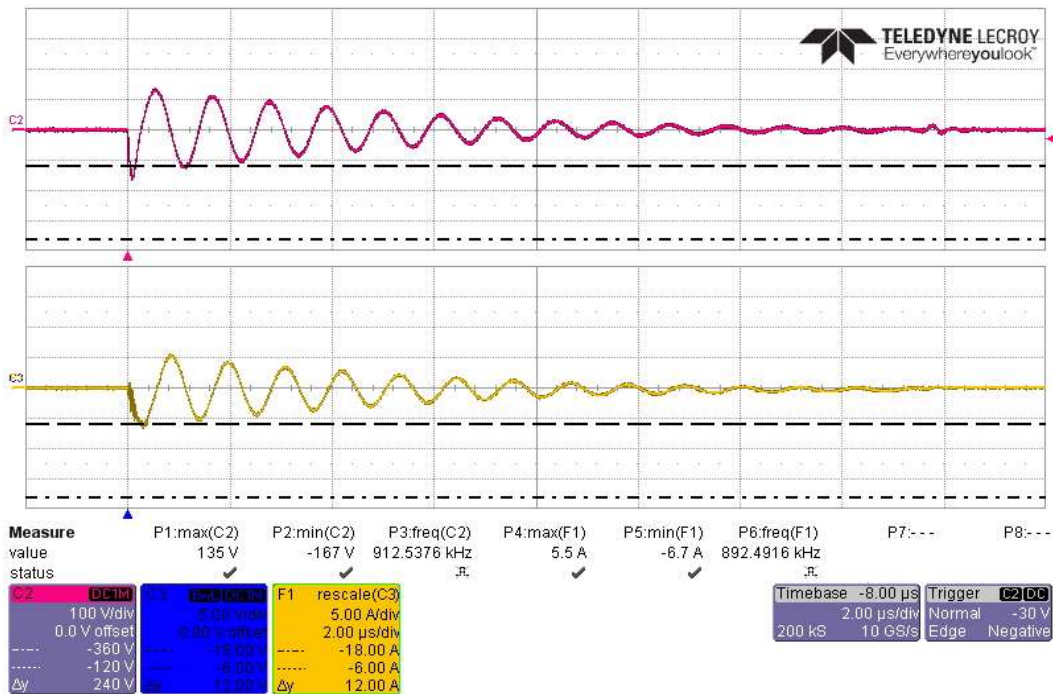

Actual Test CS117 Waveform #3 at 1MHz, First Transient -360V/6A, on Battery Return Side

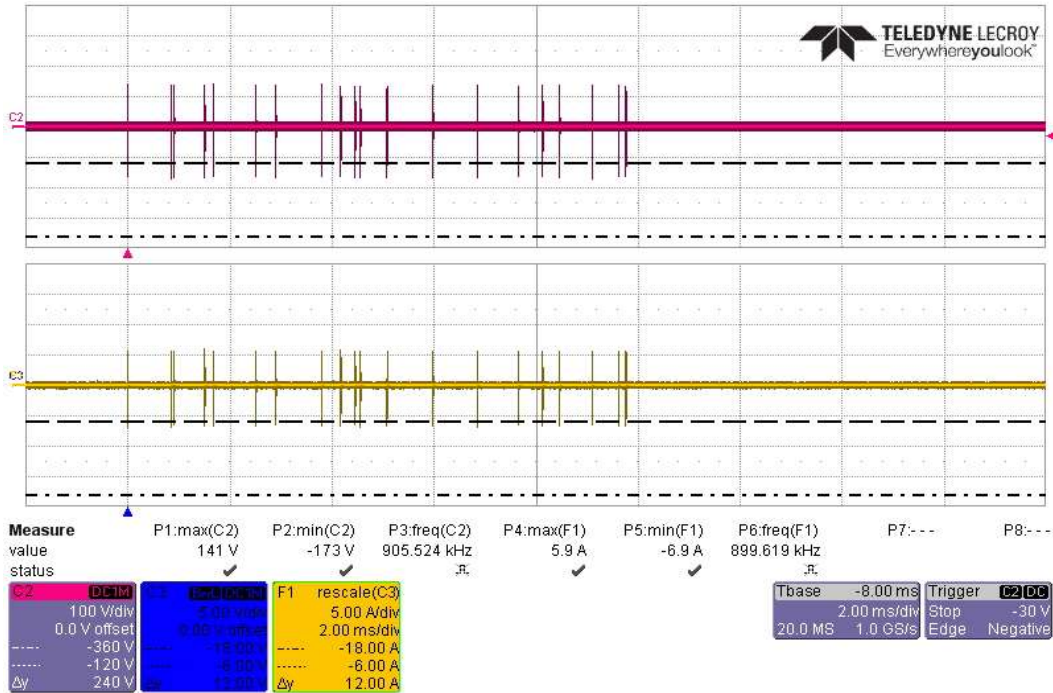

Actual Test CS117 Waveform #3 at 1MHz, 20 Transients -360V/6A, on Battery Return Side

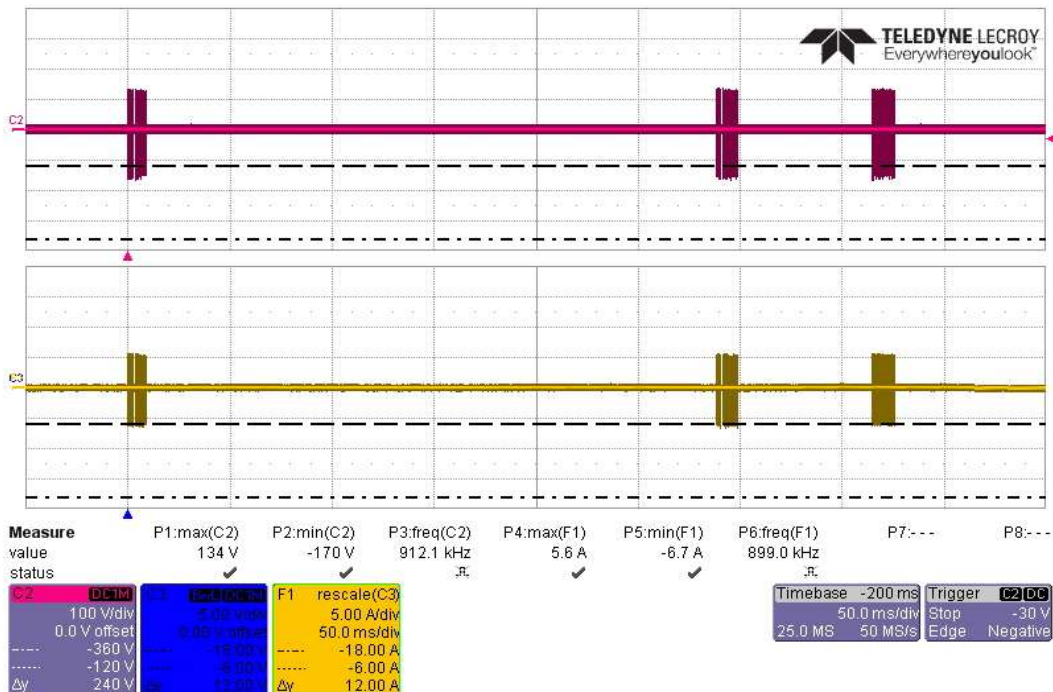

Actual Test CS117 Waveform #3 at 1MHz, 3 Bursts -360V/6A, on Battery Return Side

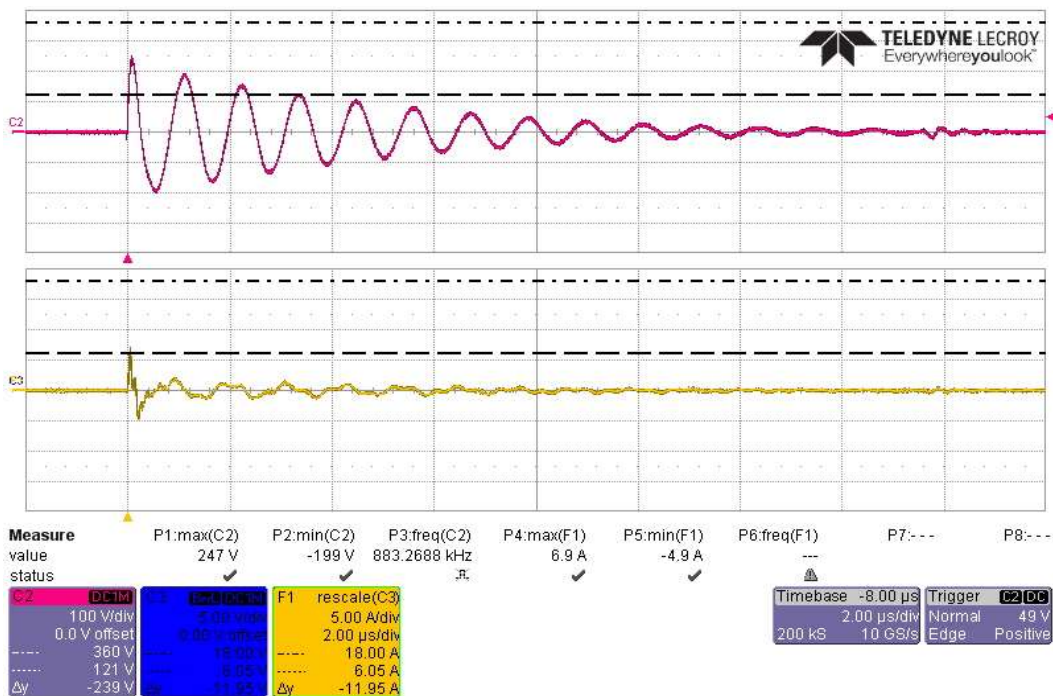

Actual Test CS117 Waveform #3 at 1MHz, First Transient +360V/6A, on Battery Bundle

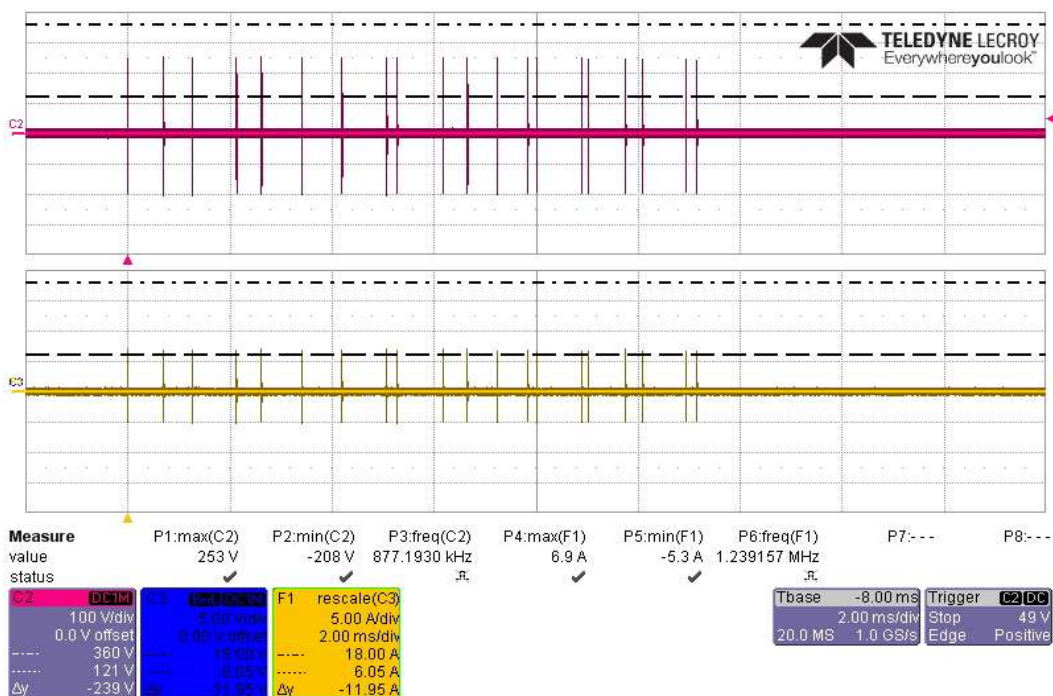

Actual Test CS117 Waveform #3 at 1MHz, 20 Transients +360V/6A, on Battery Bundle

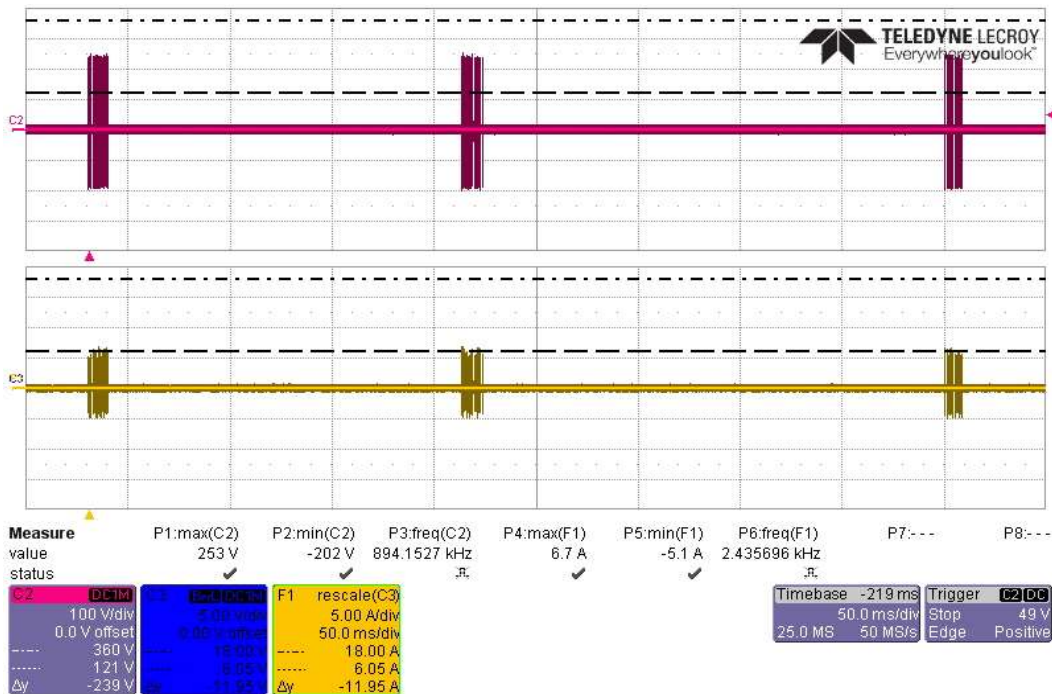

Actual Test CS117 Waveform #3 at 1MHz, 3 Bursts +360V/6A, on Battery Bundle

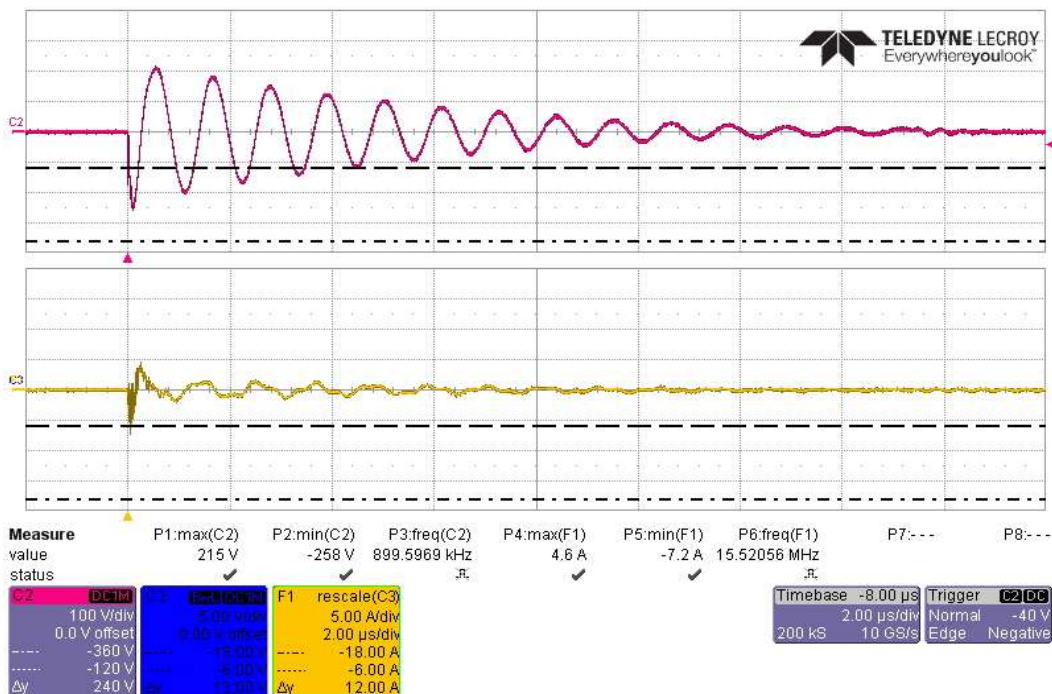

Actual Test CS117 Waveform #3 at 1MHz, First Transient -360V/6A, on Battery Bundle

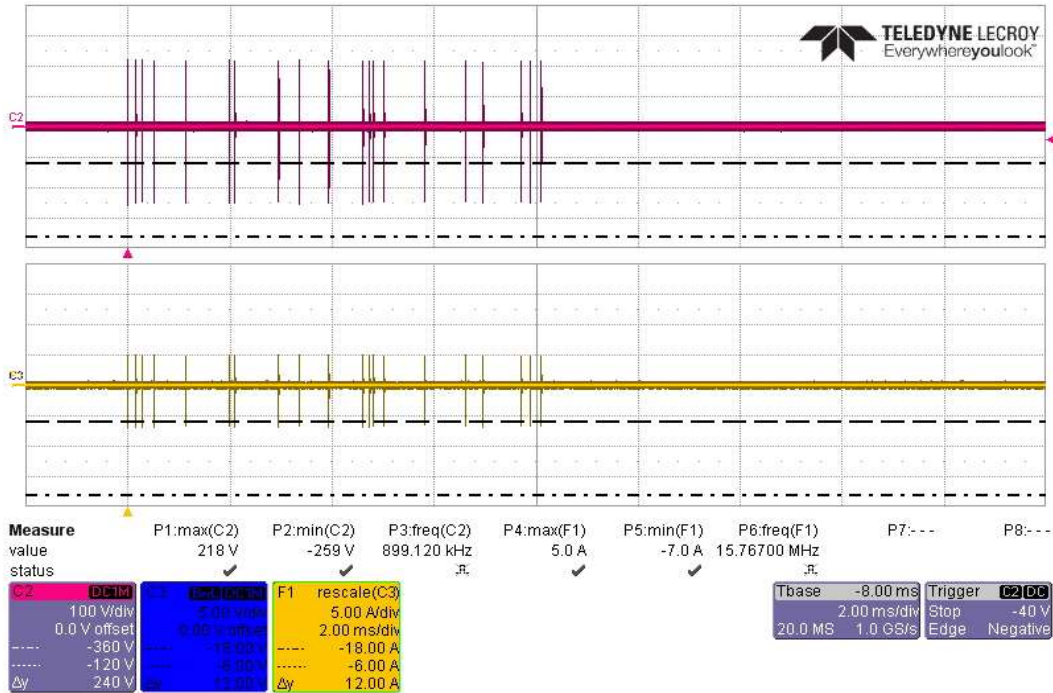

Actual Test CS117 Waveform #3 at 1MHz, 20 Transients -360V/6A, on Battery Bundle

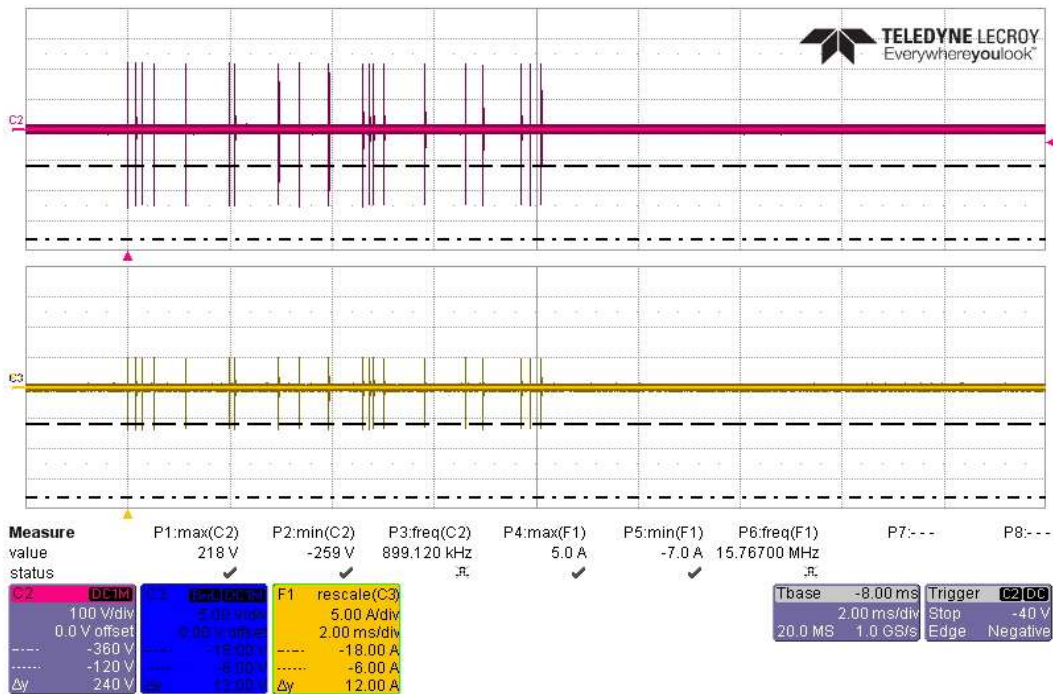

Actual Test CS117 Waveform #3 at 1MHz, 3 Bursts -360V/6A, on Battery Bundle

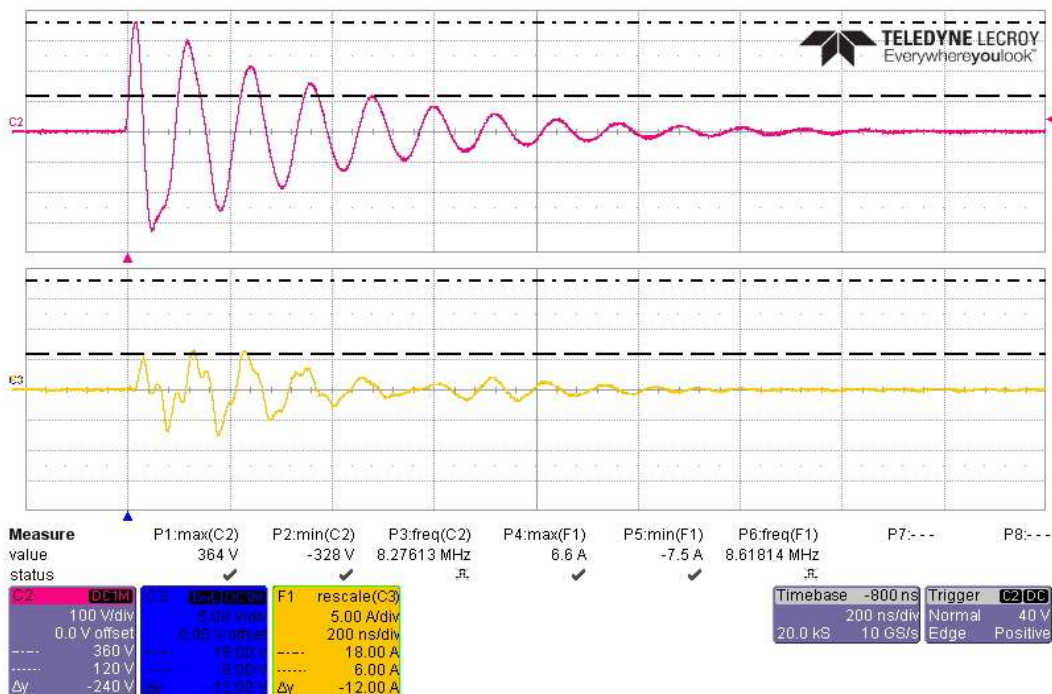
CS117 Actual Test Multiple Burst Waveform #3 at 10MHz with 360V/6A

Actual Test CS117 Waveform #3 at 10MHz, First Transient +360V/6A, on Battery High Side

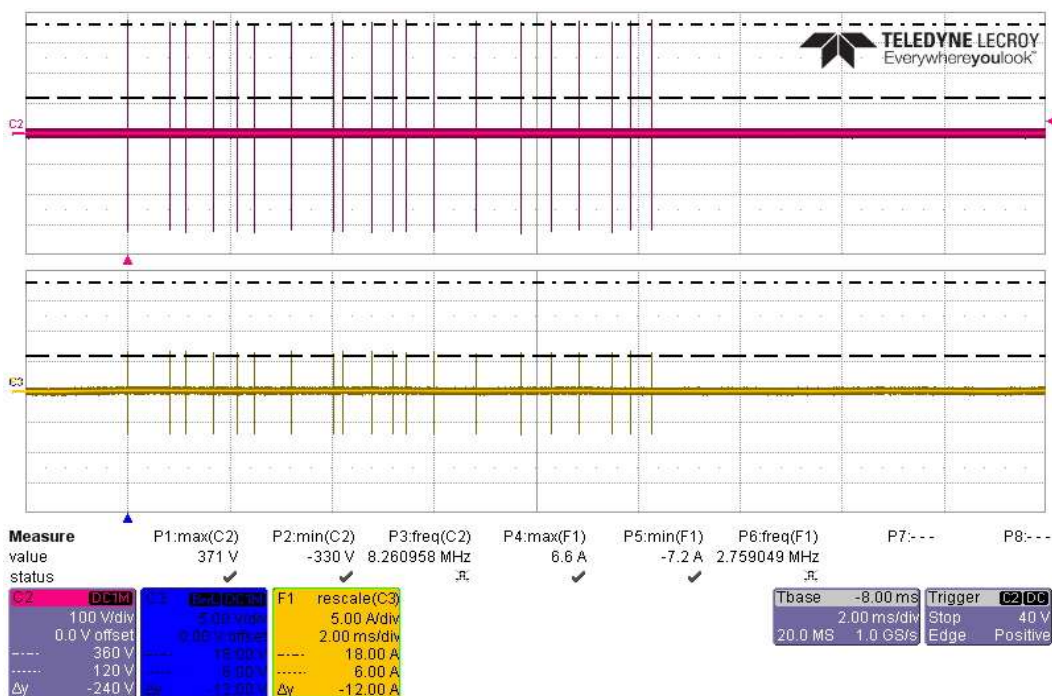

Actual Test CS117 Waveform #3 at 10MHz, 20 Transients +360V/6A, on Battery High Side

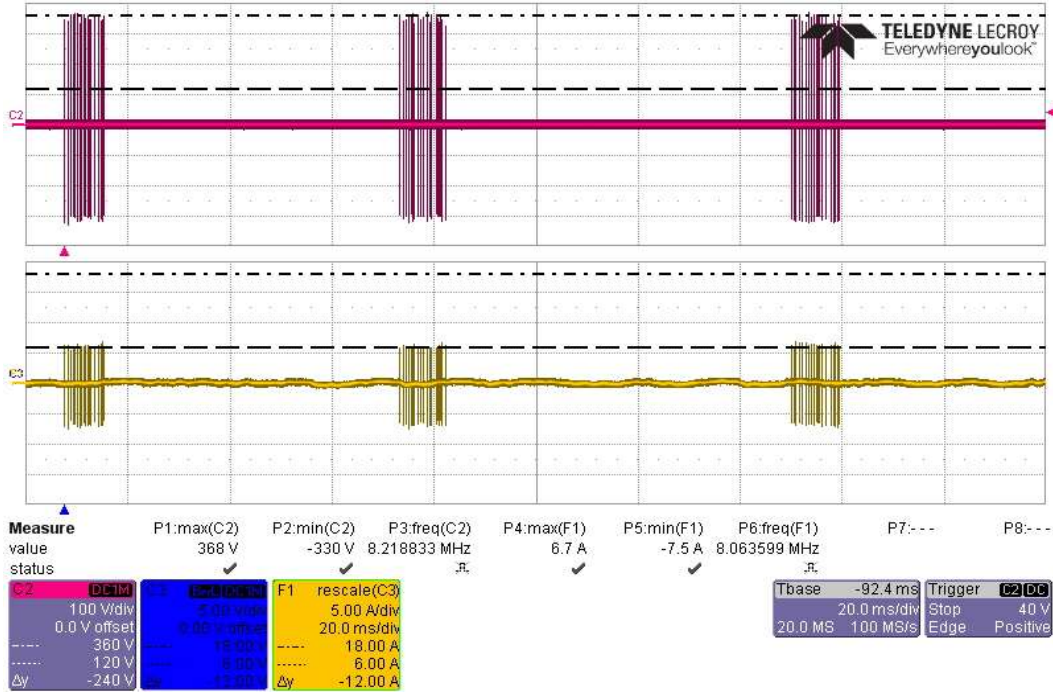

Actual Test CS117 Waveform #3 at 10MHz, 3 Bursts +360V/6A, on Battery High Side

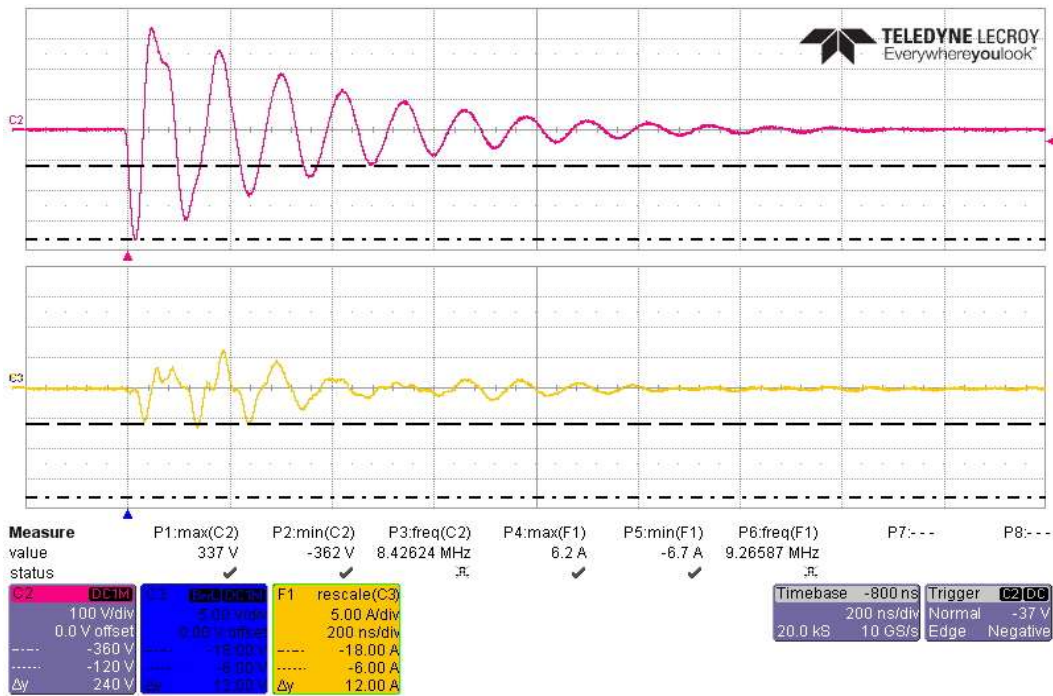

Actual Test CS117 Waveform #3 at 10MHz, First Transient -360V/6A, on Battery High Side

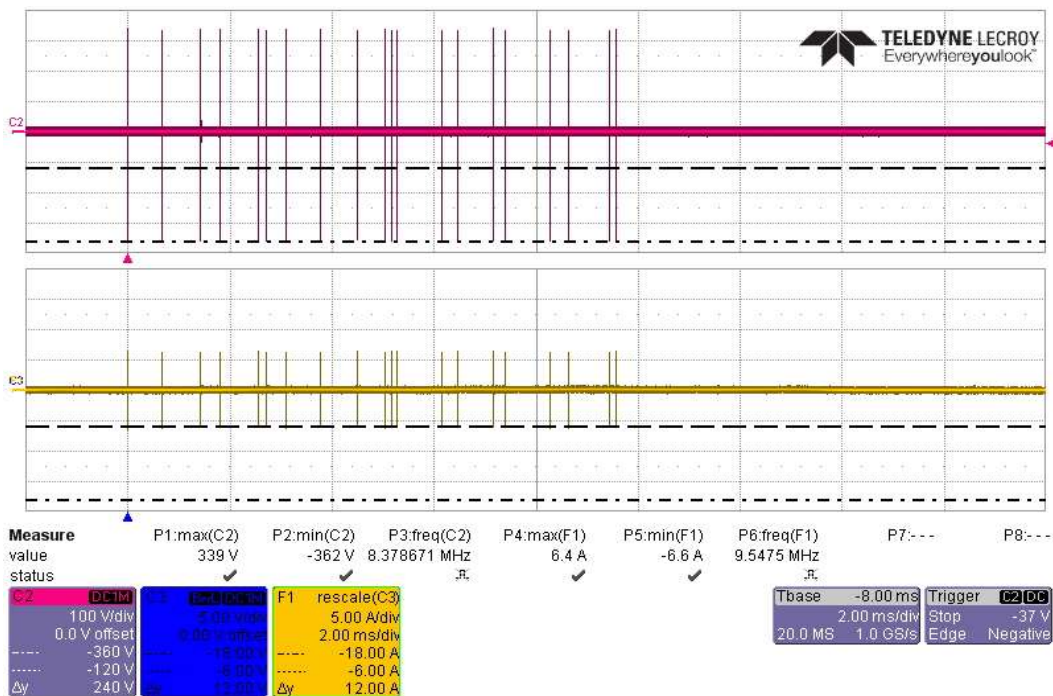

Actual Test CS117 Waveform #3 at 10MHz, 20 Transients -360V/6A, on Battery High Side

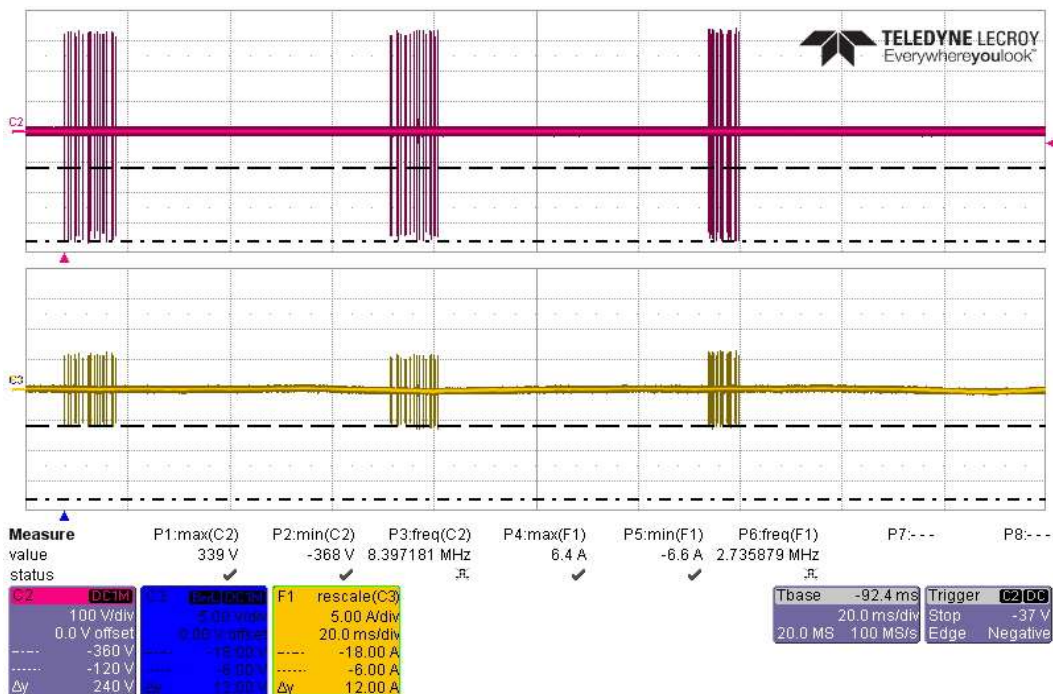

Actual Test CS117 Waveform #3 at 10MHz, 3 Bursts -360V/6A, on Battery High Side

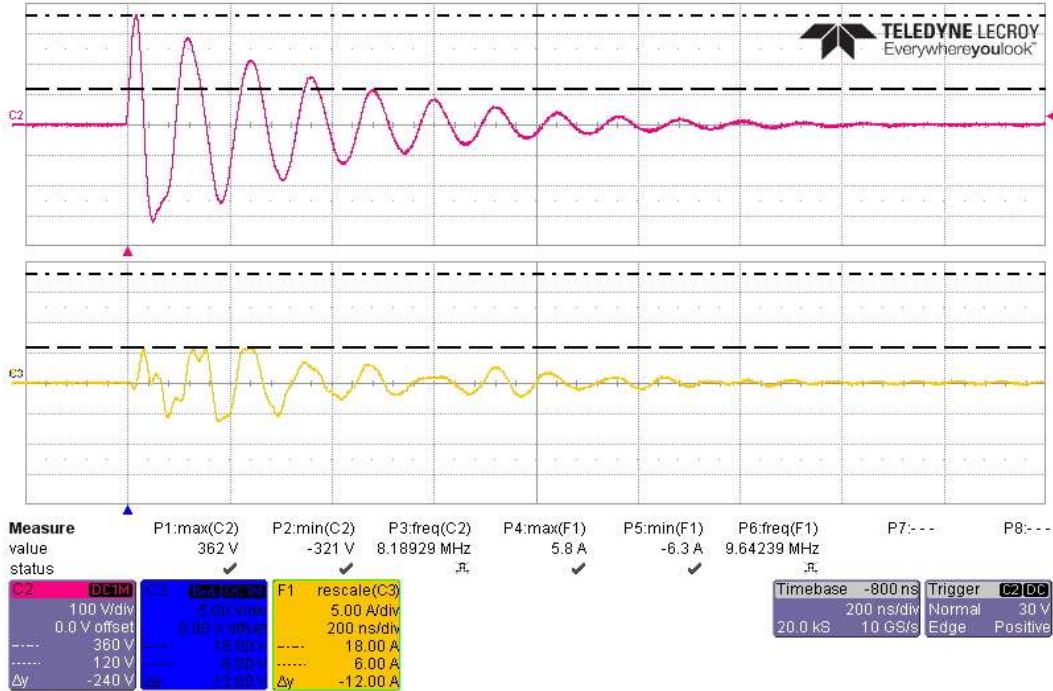

Actual Test CS117 Waveform #3 at 10MHz, First Transient +360V/6A, on Battery Return Side

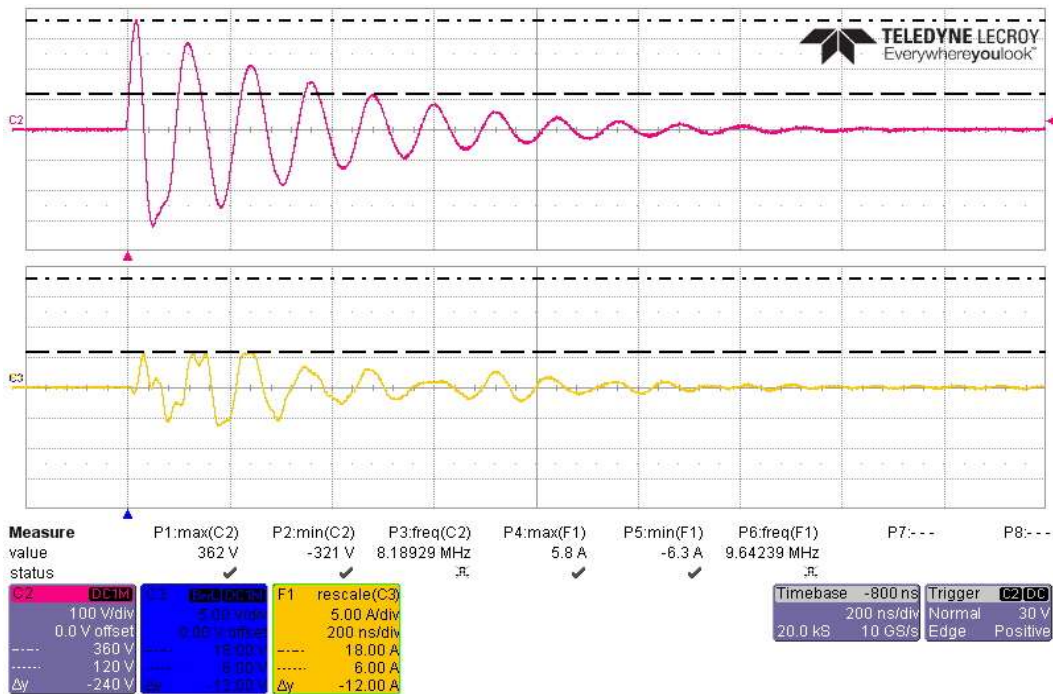

Actual Test CS117 Waveform #3 at 10MHz, 20 Transients +360V/6A, on Battery Return Side

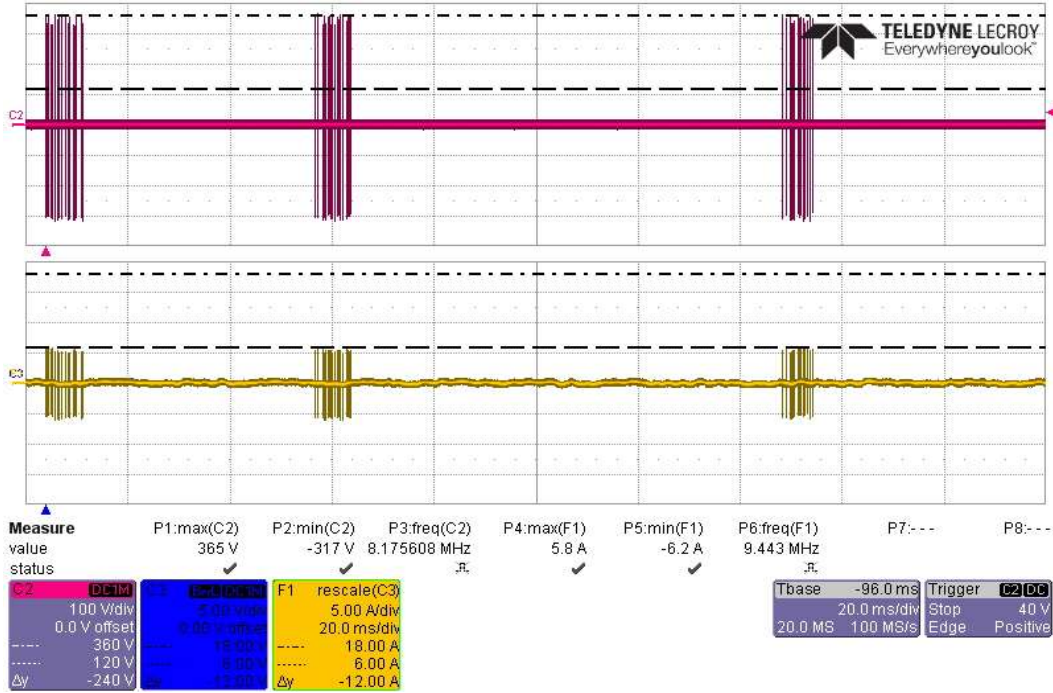

Actual Test CS117 Waveform #3 at 10MHz, 3 Bursts +360V/6A, on Battery Return Side

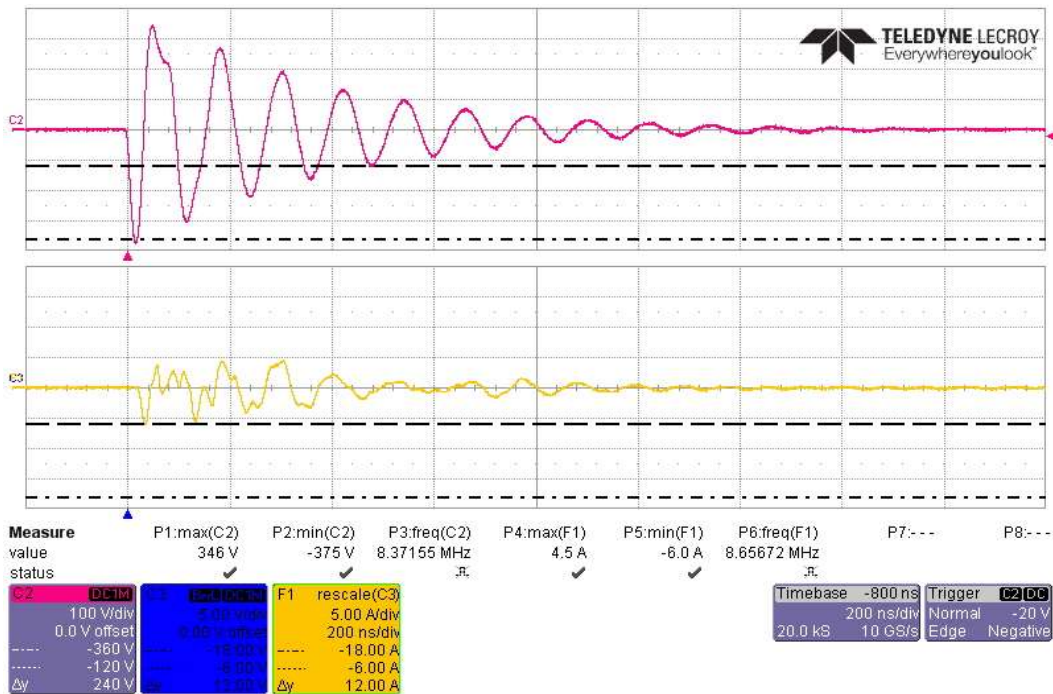

Actual Test CS117 Waveform #3 at 10MHz, First Transient -360V/6A, on Battery Return Side

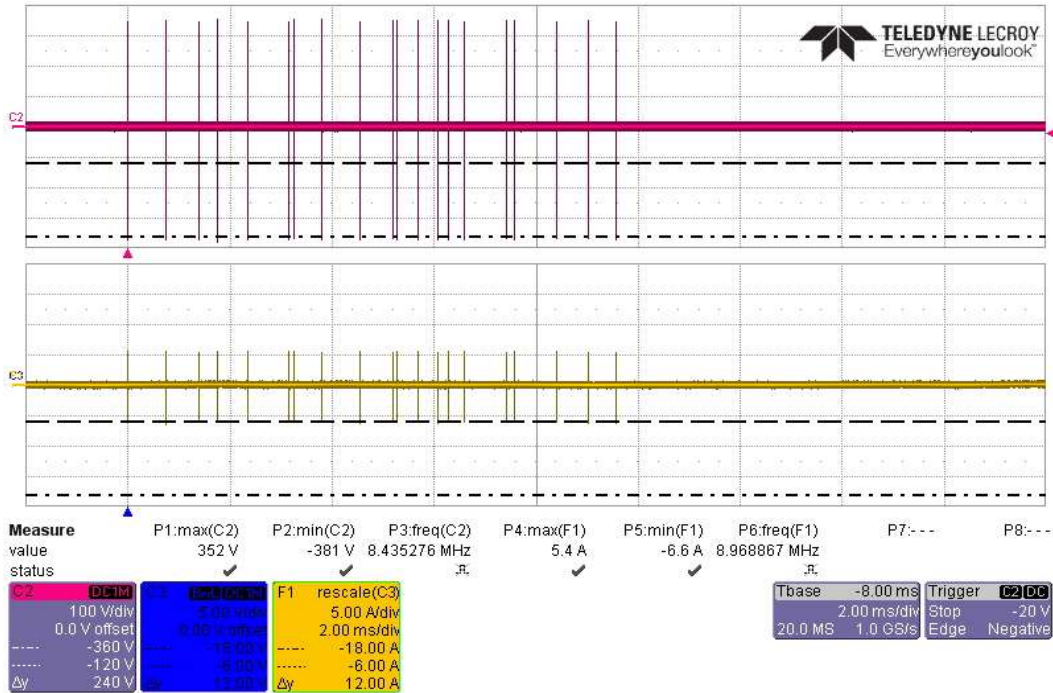

Actual Test CS117 Waveform #3 at 10MHz, 20 Transients -360V/6A, on Battery Return Side

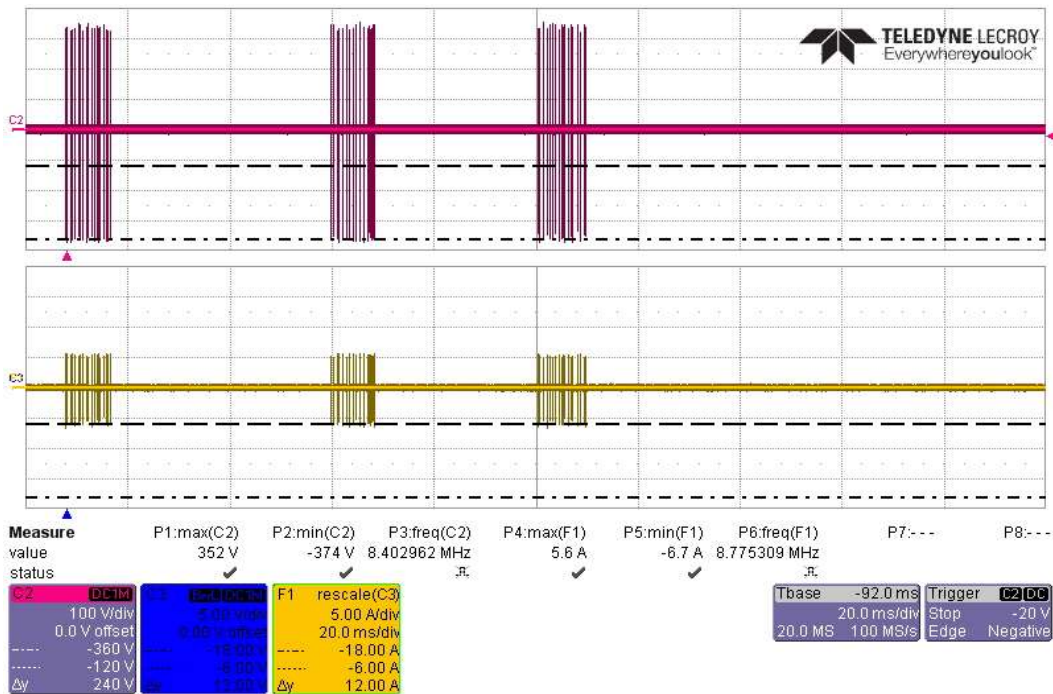

Actual Test CS117 Waveform #3 at 10MHz, 3 Bursts -360V/6A, on Battery Return Side

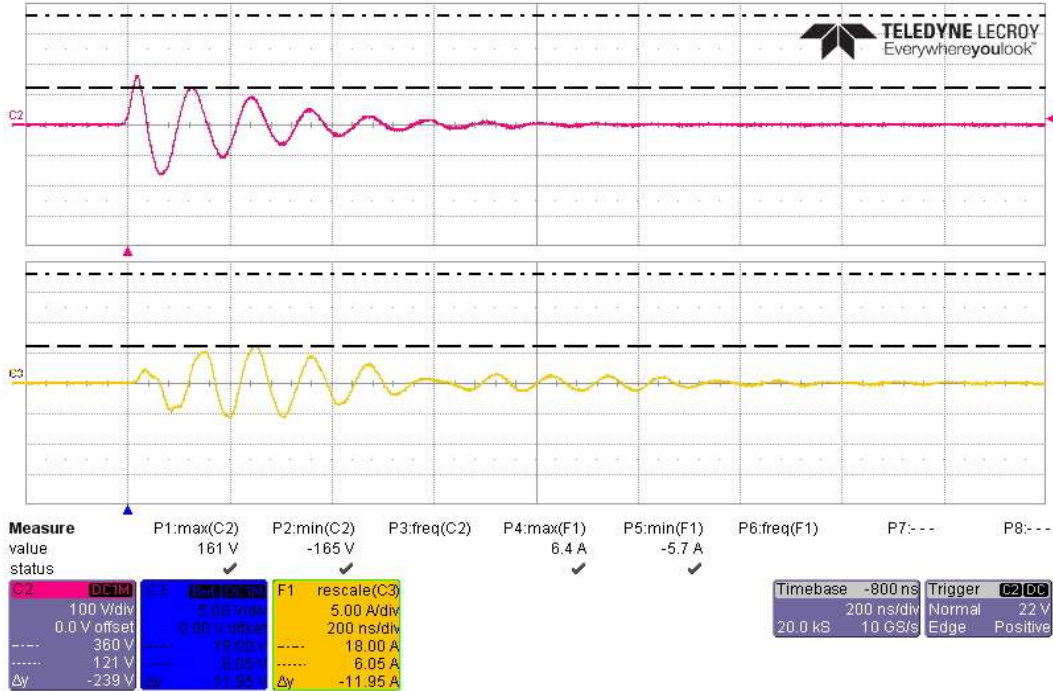

Actual Test CS117 Waveform #3 at 10MHz, First Transient +360V/6A, on Battery Bundle

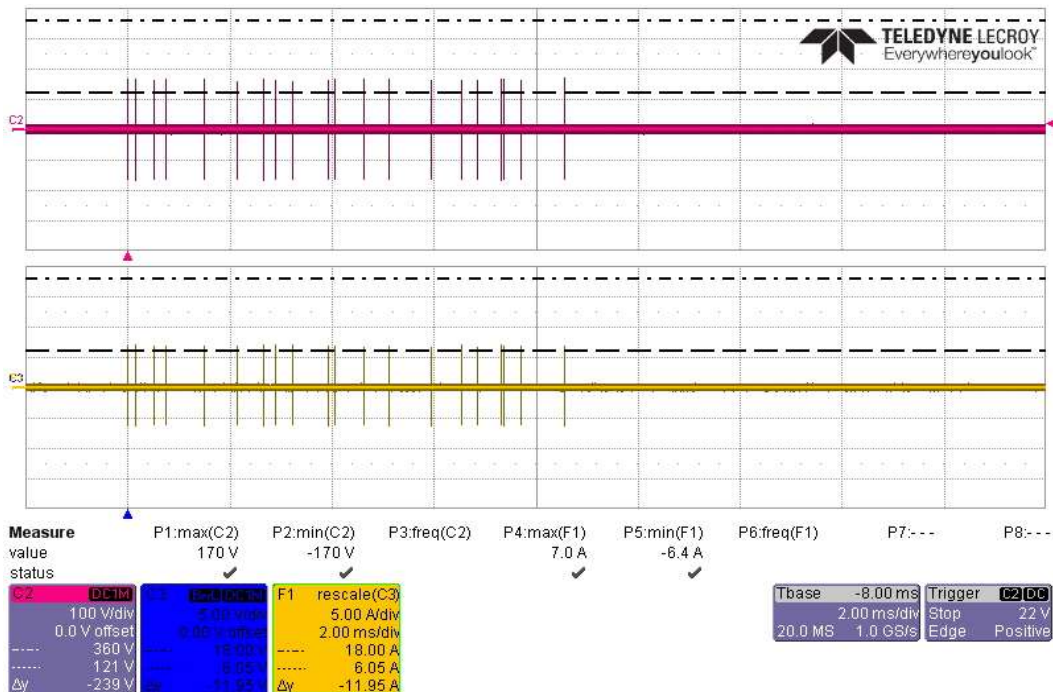

Actual Test CS117 Waveform #3 at 10MHz, 20 Transients +360V/6A, on Battery Bundle

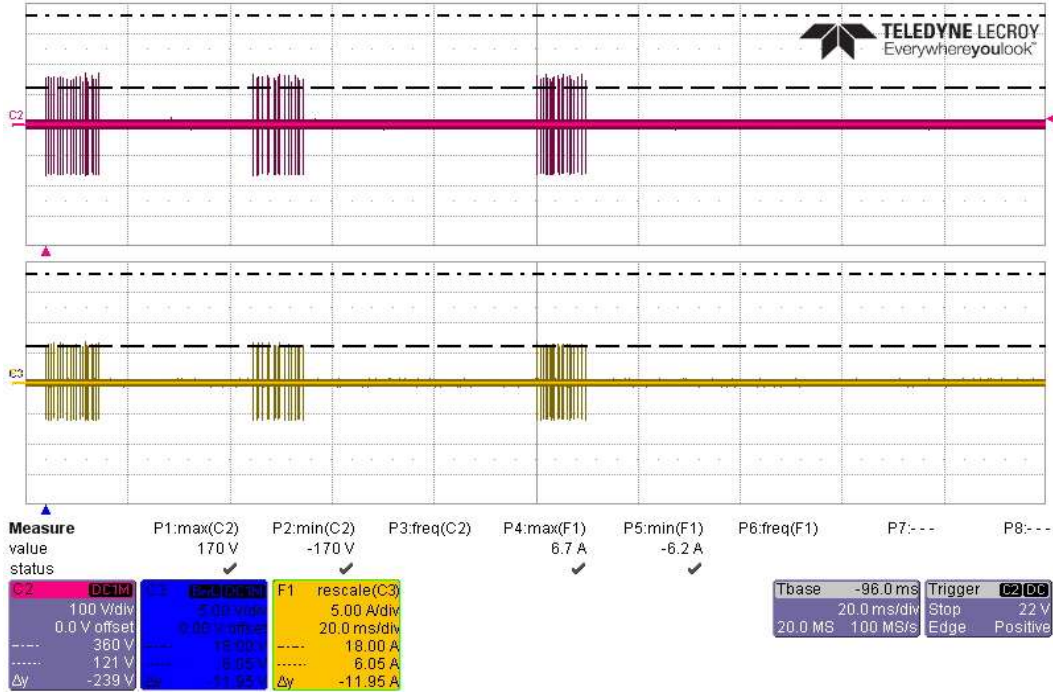

Actual Test CS117 Waveform #3 at 10MHz, 3 Bursts +360V/6A, on Battery Bundle

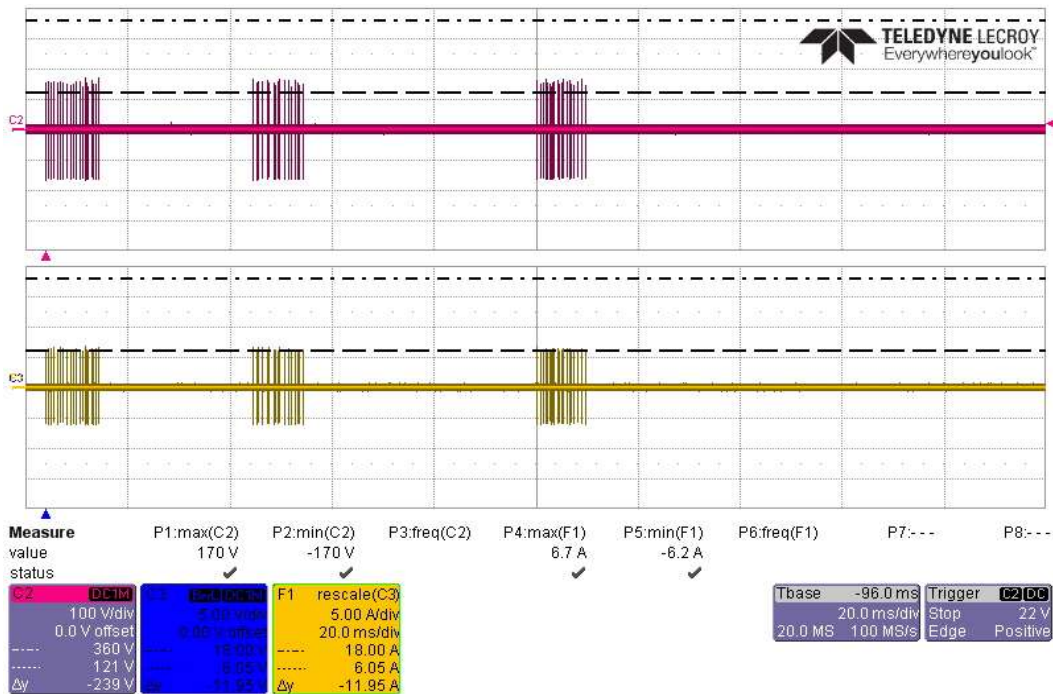

Actual Test CS117 Waveform #3 at 10MHz, First Transient -360V/6A, on Battery Bundle

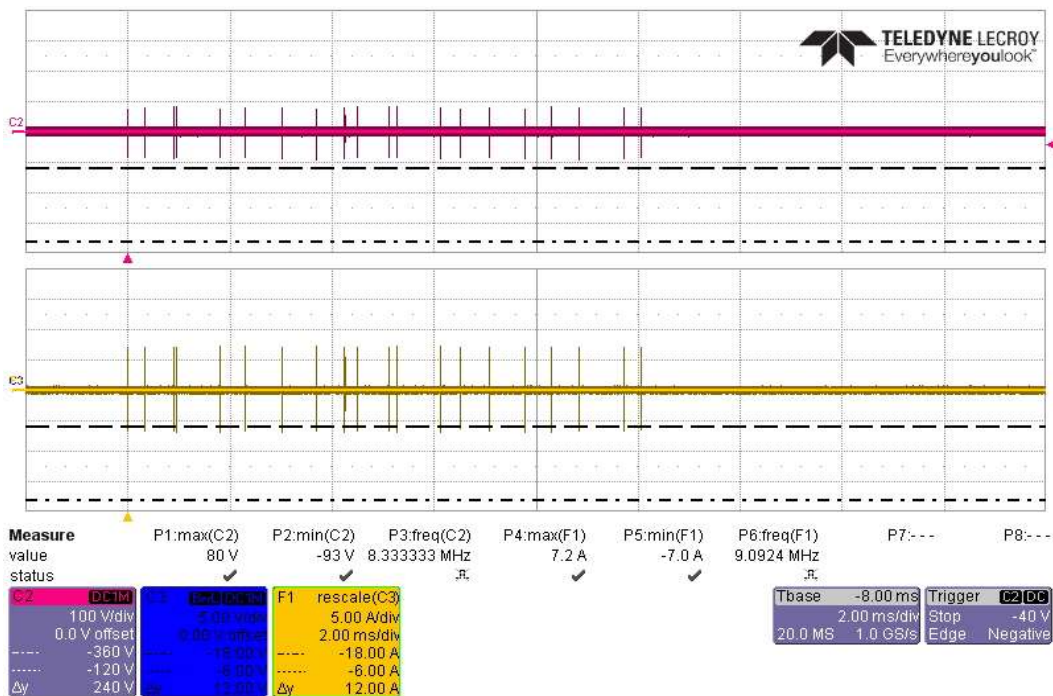

Actual Test CS117 Waveform #3 at 10MHz, 20 Transients -360V/6A, on Battery Bundle

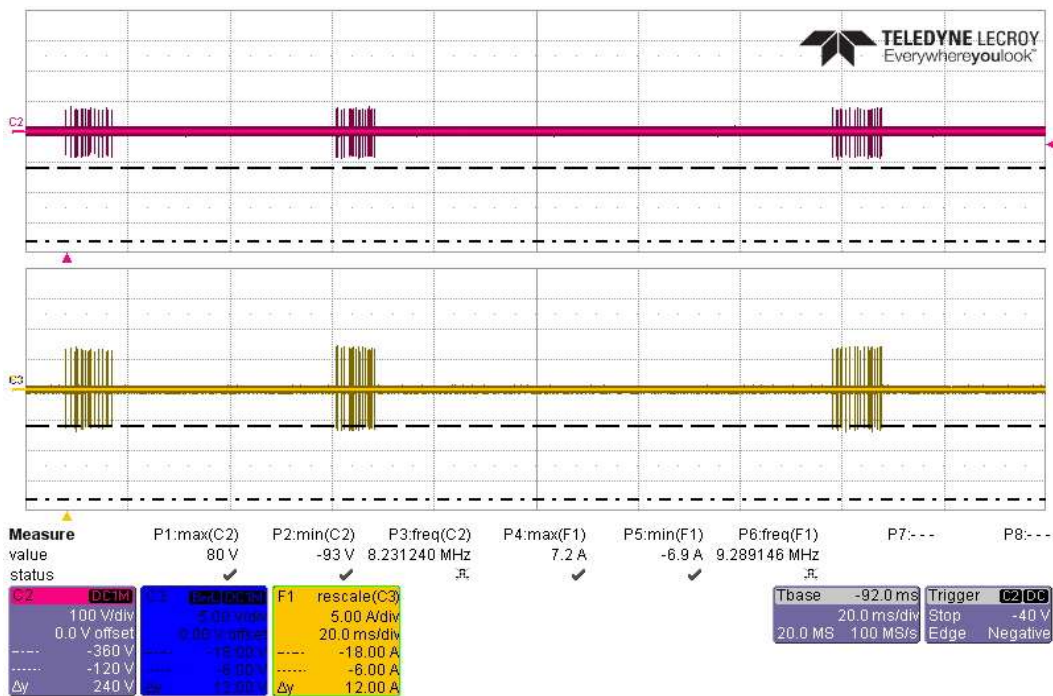

Actual Test CS117 Waveform #3 at 10MHz, 3 Bursts -360V/6A, on Battery Bundle

5.3.3 CS117 Test Equipment

CS117 Test Equipment List			
Element ID#	Manufacturer/Model	Duration	Cal Due
WC021313	Solar LISN 8028-50-TS-24-BNC 10K-50MHz	12 months	4/11/2025
WC021338	Solar LISN, 8028-50-TS-24BNC, Above 20MHz	12 months	5/13/2025
WC021084	LeCroy WaveRunner Oscilloscope (Digital), WR104Mxi	12 months	1/19/2025
TOTA	Pearson 100x Current Monitor, Model: 101, SN: 150271	36 months	3/15/2027
WC021645	EMC-Partner Modular Impulse Generator Model MIG-OS-MB; WF2 & 3	NCR	N/A
WC066422	EMC-Partner Injection Transformer Model CN-MIG-BT-1540; WF2, 3 & 6	NCR	N/A
WC021644	EMC-Partner Modular Impulse Generator Model MIG0600SS; WF1, 4, 5A & 5B	NCR	N/A
WC021643	EMC-Partner Modular Impulse Generator Model MIG0600MS; WF1, 4, 5A & 5B	NCR	N/A
WC021025	EMC-Partner Coupling Transformer Model CN-GI-CI; WF1, 5A & 5B	NCR	N/A
WC018365	EMC-Partner AC-DC Decoupler2, SN: 103170	NCR	N/A

Calibration Abbreviation

NCR: No Calibration Required

NA: Not Applicable

End of Report