

# EG4<sup>®</sup> MINI-SPLIT LINE SET EXTENSION

---

## INSTALLATION GUIDE



## TABLE OF CONTENTS

1.	TECHNICAL SPECIFICATIONS .....	1
2.	PACKING LIST.....	1
3.	INSTALLATION.....	2
3.1	OVERVIEW.....	2
3.2	INSTALLATION STEPS.....	3

## 1. TECHNICAL SPECIFICATIONS

SYSTEM DATA	
DESIGN PRESSURE (PSIG)	<651 PSI
REFRIGERANT	R410A
PRE-VACUUMED REFRIGERANT LINE	16.4 ft. (5 m)
CHARGE REQUIRED PER ADDITIONAL FT	0.2 oz. (6 ml)
LIQUID VALVE DIAMETER	0.25 in. (6.35 mm)
GAS VALVE DIAMETER (12K AC/DC)	0.375 in. (9.53 mm)
GAS VALVE DIAMETER (9K/12K AC & 24K AC/DC)	0.5 in. (12.7 mm)

## 2. PACKING LIST

SUPPLIED COMPONENTS	
Quantity	Description
1	(A) 16.4 ft. (5m) line set (gas refrigerant)
1	(B) 16.4 ft. (5m) line set (liquid refrigerant)
2	Double-sided male connector
4	Retaining pin
2	Foam insulation



The photograph shows the components listed in the packing list. On the left, there are two coils of black refrigerant lines. The top coil is labeled 'A' and the bottom coil is labeled 'B'. To the right of the coils are two double-sided male connectors, four retaining pins, and two pieces of black foam insulation.

## 3. INSTALLATION

### 3.1 OVERVIEW

EG4® mini-split air conditioners include two 16.4 ft. (5m) lines, one for liquid refrigerant and one for gas refrigerant. A line set extension supports an additional 16.4 ft. (5m) between the outdoor unit to the indoor unit. When adding line set extensions, do not exceed the maximum length and maximum height difference as shown in the chart below:

ITEM	9K & 12K	24K
Maximum line set length	49 ft. (15 m)	66 ft. (25 m)
Maximum height difference between indoor and outdoor unit	26 ft. (8 m)	33 ft. (10 m)

**Note:** Any attempt to increase the line set length beyond what is specified in the table above, could result in reduced heating/cooling performance, system damage or failure, and **WILL VOID THE WARRANTY.**

Installing a line set extension adds volume to the system which may lead to an approximate 3% loss in efficiency per additional line set. To compensate for the added volume, a licensed HVAC technician can add refrigerant (.2 oz./ft.) to the system.



#### **CAUTION: When working with the refrigerant line set:**

- Do not change the length of the line set tubing as it is pre-vacuumed and ready to install. Excess tubing can be coiled behind the outdoor unit, taking care not to block its airflow.
- Use extreme caution during installation to prevent any kinks in the tubing; bent tubes may lead to leakage.
- The minimum bend radius for the line set is 4 in. (102mm).
- The ends of the tubing have protective covers on them to prevent any dirt or debris from coming in contact with the connections. Do not remove the protective covers until immediately before the connection is made.
- If the line set connections are tightened with too little torque, they will leak. If they are tightened with too much torque, the connections could suffer damage. Please refer to the torque requirements when making the connections.
- The line sets are designed to only be installed once. The seal within the line set cannot be guaranteed if they are installed more than once.
- The line set quick connects contain a compression fitting to seal and do not require a thread sealant (Teflon tape, etc.). Using a sealant may cause the connection to leak over time.
- Contact a licensed HVAC technician if there are any concerns connecting the line set connectors.

## 3.2 INSTALLATION STEPS



**NOTE:** The ends of the tubing have protective covers on them to prevent any dirt or debris from coming in contact with the connections. Do not remove the protective covers until immediately before the connection is made.

Be careful to align all the line set connections correctly, making sure the dimensions of each refrigerant line set and the adapter match in diameter. Unscrew the protective caps and place the threaded connector just inside the threads of opposite end and tighten the first few threads by hand.

The line set extensions should be installed during the initial installation of the indoor and outdoor units. This line set extension kit is not intended to extend the line sets of a system that has already released refrigerant into the system by opening the refrigerant valves on the outdoor unit.

The installation steps below pickup after the indoor unit is installed to the included line set and the outdoor unit secured in place. See the image below for the line set extension and line set adapter installation locations.

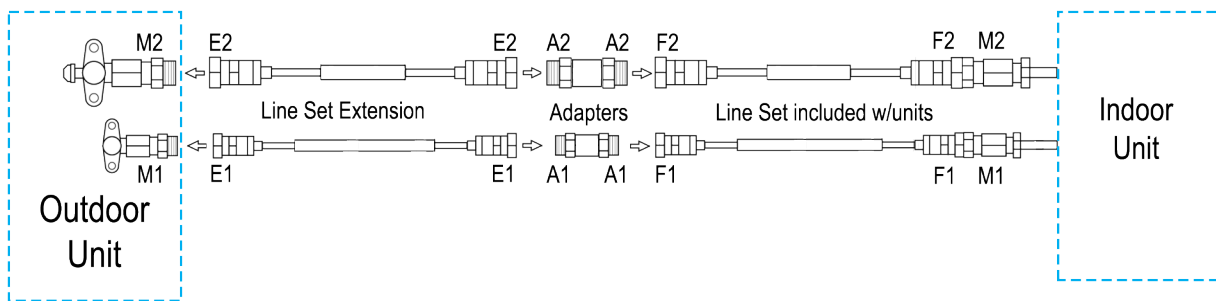

1. Verify the outdoor unit is securely fastened in place and the line sets shipped with the indoor/outdoor units are connected to the indoor unit as described in the Mini-Split User Manual.
2. Prepare the line set extension set by carefully unwinding it to the length required to make the connection from outdoor unit to the line set installed to the indoor unit. Only unwind as much as necessary and allow the remaining line to remain coiled.
3. Connect the male adapter connector “A1” to the existing line set connector “F1” coming from the indoor unit. Tighten to 19-22 ft-lbs. (25-30Nm).
4. Connect the opposite end of male adapter “A1” to the line set extension “E1”. Tighten to 19-22 ft-lbs. (25-30Nm).
5. Connect the opposite end of the line set extension connector “E1” to the outdoor unit connector “M1”. Tighten to 19-22 ft-lbs. (25-30Nm).
6. Repeat the steps above for second line set using the line set extension and male adapter. Be sure to tighten all connections to 19-22 ft-lbs. (25-30Nm).
7. Install the included retaining pins into each end of the line set adapters to ensure the connections remain tight.
8. Wrap the exposed adapter area with the included foam insulation. Wrap the insulation with tape (not included).
9. Return to the Minisplit User Manual section 6.6 to continue the installation.

9k & 12k  
User Manual



12k & 24k Hybrid  
User Manual







## CONTACT US

[support@eg4electronics.com](mailto:support@eg4electronics.com)

(903) 609-1988

[www.eg4electronics.com](http://www.eg4electronics.com)