

# EG4® LIFEPOWER4 48V V2 & V3 SERVER RACK

## CONNECTIONS OVERVIEW & PARALLELING GUIDE



## TABLE OF CONTENTS

1.	TECHNICAL SPECIFICATIONS .....	1
2.	BATTERY SAFETY .....	3
2.1	SAFETY INSTRUCTIONS.....	3
2.2	IMPORTANT SAFETY NOTIFICATIONS .....	3
3.	SÉCURITÉ DE LA BATTERIE.....	5
3.1	CONSIGNES DE SÉCURITÉ.....	5
3.2	NOTIFICATIONS DE SÉCURITÉ IMPORTANTES.....	5
4.	INSTALLING THE BATTERY .....	7
4.1	BATTERY DIAGRAM (NO DIPS).....	7
4.2	BATTERY DIAGRAM (WITH DIPS) .....	8
4.3	PRE-WIRE STEPS AND WIRING.....	9
4.4	MULTIMETER TESTING AND WIRING.....	9
5.	EXAMPLE CONNECTION CONFIGURATIONS.....	10
5.1	ADDITIONAL CONFIGURATIONS WITH EG4 BATTERY MODELS.....	11
6.	BATTERY COMMUNICATIONS.....	13
6.1	AUTO-ID BMS PROTOCOL FEATURE.....	13
6.2	AUTO-ID SETUP .....	14
6.3	BMS COMMUNICATION WIRING.....	15
6.4	MULTIPLE BATTERIES IN PARALLEL (NO DIPS).....	16
6.5	MULTIPLE BATTERIES IN PARALLEL (WITH DIPS) .....	17
7.	PROTOCOL SELECT.....	18
7.1	PROTOCOL ID DIP SWITCH .....	18
7.2	RS485 PROTOCOL AUTODETECTION .....	19
8.	EMERGENCY STOP (RSD, ESS DISCONNECT) .....	20
9.	WARRANTY INFORMATION.....	20
10.	CHANGELOG .....	21

## 1. TECHNICAL SPECIFICATIONS

MODULE OPERATING PARAMETERS			
PARAMETER	BMS	RECOMMENDED SYSTEM SETTING	
VOLTAGE	51.2V	-	
CAPACITY	100Ah	-	
CHARGING VOLTAGE (BULK/ABSORB)	56.8V	-	
LOW DC CUTOFF/SOC CUTOFF	44.8V	48V ± 0.2V*   20%**	
CHARGING CURRENT	100A (Max. continuous)	50A	
DISCHARGING CURRENT	100A (Max. continuous)	50A	
MAXIMUM CONTINUOUS DISCHARGE RATE	5.12kW	-	
NAMEPLATE ENERGY CAPACITY	5.12kWh	-	
BMS PARAMETERS			
CHARGE	SPEC	DELAY	RECOVERY
CELL VOLTAGE PROTECTION	3.8V	1s	3.45V
MODULE VOLTAGE PROTECTION	60.0V	1s	55.2V
OVER CHARGING CURRENT 1	>102A	10s	-
OVER CHARGING CURRENT 2	≥120A	3s	-
TEMPERATURE PROTECTION	<23°F or >158°F <-5°C or >70°C	1s	<32°F or >140°F >0°C or 60°C
DISCHARGE			
CELL VOLTAGE PROTECTION	2.3V	1s	3.1V
MODULE VOLTAGE PROTECTION	44.8V	1s	48.0V
OVER DISCHARGING CURRENT 1	>102A	10s	60s
OVER DISCHARGING CURRENT 2	>150A	3s	60s
SHORT-CIRCUIT	>300A	<0.1ms	-
TEMPERATURE PROTECTION	<-4°F or >167°F <-20°C or >75°C	1s	>14°F or <149°F >-10°C or <65°C
PCB TEMP PROTECTION	>230°F (>110°C)	1s	<176°F (<80°C)

\*When running the battery in open-loop communications, note that battery SOC% and battery voltage do not directly correlate.

\*\*EG4 recommends this value be set no lower than 20% to maintain the recommended 80% depth of discharge.

GENERAL SPECIFICATIONS			
PARAMETER	SPEC	TYPE	CONDITION
CELL BALANCE	120mA	Passive Balance	Cell Voltage Difference >40mV
TEMPERATURE ACCURACY	3%	Cycle Measurement	Measuring Range 40°F – 212°F (-40°C – 100°C)
VOLTAGE ACCURACY	0.5%	Cycle Measurement	For Cells/Module
CURRENT ACCURACY	3%	Cycle Measurement	Measurement Range +/-200A
SOC	5%	-	Integral Calculation
POWER CONSUMPTION (SLEEP & OFF MODE)	<300uA	-	Storage/Transport/Standby
POWER CONSUMPTION (OPERATING)	<25mA	-	Charging/Discharging
COMMUNICATION PORTS	RS485/CAN	-	Customizable
MAXIMUM MODULES IN SERIES			1
MAXIMUM MODULES IN PARALLEL			64
E-STOP FUNCTION			Yes
DIMENSION (H×W×D)	6.1 in × 19 in × 17.4 in (155 mm × 442 mm × 470 mm)		
WEIGHT	99.6 lbs. (45.2 kg)		
ENVIRONMENTAL PARAMETERS			
CHARGING RANGE	32°F – 122°F (0°C to 50°C)		
DISCHARGING RANGE	-4°F – 131°F (-20°C – 55°C)		
STORAGE RANGE	32°F – 113°F (0°C – 45°C)		
OPERATING ALTITUDE	<16404 ft. (<5000 m)		
INGRESS PROTECTION	IP20		
STANDARDS AND CERTIFICATIONS			
MODULE	UL 1973 ETL Recognized Component Certification UL9540A (Passed) UL9540 listed with 18kPV-12LV		

## 2. BATTERY SAFETY

### 2.1 SAFETY INSTRUCTIONS

Before any work begins, carefully read all safety instructions, and always observe them when working on or with the battery. The installation must follow all applicable national or local standards and regulations. Consult with the local AHJ to obtain the proper permits and permissions before installation.

**Incorrect installation may cause:**

- *Injury or death to the installer, operator or third party*
- *Damage to the battery or other attached equipment*

### 2.2 IMPORTANT SAFETY NOTIFICATIONS



#### **DANGER: Hazardous Voltage Circuits!**

There are various safety concerns that must be carefully observed before, during, and after the installation, as well as during future operation and maintenance. The following are important safety notifications for the installer and any end users of this product under normal operating conditions.

1. **Do not disassemble the battery.** Contact the distributor for any issues that need repair for more information and proper handling instructions. Incorrect servicing or re-assembly may result in a risk of electric shock or fire and void the warranty.
2. **Never short-circuit DC inputs.** Short-circuiting the battery may result in a risk of electric shock or fire and can lead to severe injury or death and/or permanent damage to the unit and/or any connected equipment.
3. **Use caution when working with metal tools on or around batteries and systems.** **Risk** of electrical arcs and/or short circuiting of equipment can lead to severe injury or death and equipment damage.
4. **Beware of high battery current.** Ensure that the battery module breakers and/or on/off switches are in the “open” or “off” position before installing or working on the battery. Use a voltmeter to confirm there is no voltage present to avoid electric shock.
5. **Do not make any connections or disconnections to the system while the batteries are operating.** Damage to system components or risk of electrical shock may occur if working with energized batteries.
6. Make sure the battery and rack are properly grounded.
7. An installer should make sure to be well protected by reasonable and professional insulative equipment [e.g., personal protective equipment (PPE)].
8. Before installing, operating, or maintaining the system, it is important to inspect all existing wiring to ensure it meets the appropriate specifications and conditions for use.
9. Ensure that the battery and system component connections are secure and proper to prevent damage or injuries caused by improper installation.



## **WARNING: TO REDUCE THE RISK OF INJURY, READ ALL INSTRUCTIONS!**

All work on this product (system design, installation, operation, setting, configuration, and maintenance) must be carried out by qualified personnel. To reduce the risk of electric shock, do not perform any servicing other than those specified in the operating instructions unless qualified to do so.

1. Read all instructions before commencing installation. For electrical work, follow all local and national wiring standards, regulations, and these installation instructions. All wiring should be in accordance with the National Electrical Code (NEC), ANSI/NFPA 70.
2. The battery and system can connect with the utility grid only if the utility provider permits. Consult with the local AHJ before installing this product for any additional regulations and requirements for the area.
3. All warning labels and nameplates on this battery should be clearly visible and must not be removed or covered.
4. The installer should consider the safety of future users when choosing the battery's correct position and location as specified in this manual.
5. Keep children away from touching or misusing the battery and relevant systems.

The battery is designed to stop charging when reaching the low threshold of 32°F. If charging current is observed when the internal battery temperature is below 32°F, disconnect battery immediately and consult distributor.



## **WARNING!**

**Cancer and Reproductive Harm – See [www.P65Warnings.ca.gov](http://www.P65Warnings.ca.gov) for more details.**

## **DISCLAIMER**

EG4 reserves the right to make changes to the material herein at any time without notice.

Please refer to [www.eg4electronics.com](http://www.eg4electronics.com) for the most updated version of our manuals/spec sheets.

## 3. SÉCURITÉ DE LA BATTERIE

### 3.1 CONSIGNES DE SÉCURITÉ

Avant de commencer tout travail, lisez attentivement toutes les consignes de sécurité et respectez-les toujours lorsque vous travaillez sur ou avec la batterie. L'installation doit être conforme à toutes les normes et réglementations nationales ou locales applicables. Consultez l'autorité compétente locale et/ou le service public pour obtenir les permis et les autorisations appropriés avant l'installation.

#### Une installation incorrecte peut entraîner les effets suivants :

- *Blessure ou décès de l'installateur, de l'exploitant ou d'un tiers*
- *Domages à la batterie ou à tout autre équipement attaché*

### 3.2 NOTIFICATIONS DE SÉCURITÉ IMPORTANTES



#### **DANGER:** *Circuits à haute tension!*

Il existe divers problèmes de sécurité qui doivent être soigneusement observés avant, pendant et après l'installation, ainsi que lors de l'utilisation et de la maintenance futures. Ce qui suit sont des notifications de sécurité importantes pour l'installateur et tout utilisateur final de ce produit dans des conditions de fonctionnement normales.

1. **Ne démontez pas la batterie.** Contactez le distributeur pour tout problème nécessitant une réparation pour plus d'informations et des instructions de manipulation appropriées. Un entretien ou un remontage incorrect peut entraîner un risque d'électrocution ou d'incendie et annuler la garantie.
2. **Ne court-circuitez jamais les entrées CC.** Un court-circuit de la batterie peut entraîner un risque d'électrocution ou d'incendie et peut entraîner des blessures graves ou la mort et/ou des dommages permanents à l'appareil et/ou à tout équipement connecté.
3. **Soyez prudent lorsque vous travaillez avec des outils métalliques sur ou à proximité des batteries et des systèmes.** Le risque d'arcs électriques et/ou de court-circuit de l'équipement peut entraîner des blessures graves ou la mort et des dommages à l'équipement.
4. **Attention au courant de batterie élevé.** Assurez-vous que les disjoncteurs du module de batterie et/ou les interrupteurs marche/arrêt sont en position « ouvert » ou « arrêt » avant d'installer ou de travailler sur la batterie. Utilisez un voltmètre pour confirmer qu'il n'y a pas de tension présente afin d'éviter les chocs électriques.
5. **N'effectuez aucune connexion ou déconnexion du système pendant que les batteries fonctionnent.** Des dommages aux composants du système ou un risque d'électrocution peuvent survenir si vous travaillez avec des batteries sous tension.
6. Assurez-vous que le banc de batteries est correctement mis à la terre.
7. Un installateur doit s'assurer d'être bien protégé par un équipement isolant raisonnable et professionnel [par exemple, un équipement de protection individuelle (EPI)].
8. Avant d'installer, d'utiliser ou d'entretenir le système, il est important d'inspecter tout le câblage existant pour s'assurer qu'il répond aux spécifications et aux conditions d'utilisation appropriées.
9. Assurez-vous que les connexions de la batterie et des composants du système sont sécurisées et appropriées pour éviter les dommages ou les blessures causés par une mauvaise installation.



## **AVERTISSEMENT : Pour réduire le risque de blessure, lisez toutes les instructions !**

Tous les travaux sur ce produit (conception du système, installation, fonctionnement, réglage, configuration et maintenance) doivent être effectués par du personnel qualifié. Pour réduire le risque d'électrocution, n'effectuez aucun entretien autre que ceux spécifiés dans le mode d'emploi, à moins d'être qualifié pour le faire.

1. Lisez toutes les instructions avant de commencer l'installation. Pour les travaux électriques, suivez toutes les normes de câblage locales et nationales, les réglementations et ces instructions d'installation. Tout le câblage doit être conforme au Code national de l'électricité (NEC), ANSI/NFPA 70.
2. La batterie et le système ne peuvent se connecter au réseau public que si le fournisseur d'électricité l'autorise. Consultez l'AHJ local avant d'installer ce produit pour connaître les réglementations et exigences supplémentaires de la région.
3. Toutes les étiquettes d'avertissement et les plaques signalétiques de cette batterie doivent être clairement visibles et ne doivent pas être retirées ou couvertes.
4. L'installateur doit tenir compte de la sécurité des futurs utilisateurs lors du choix de la position et de l'emplacement corrects de la batterie, comme spécifié dans ce manuel.
5. Tenez les enfants à l'écart de la batterie et des systèmes concernés ou de les utiliser à mauvais escient.

La batterie est conçue pour arrêter de se charger lorsqu'elle atteint le seuil bas de 23 °F. Si un courant de charge est observé lorsque la température interne de la batterie est inférieure à 23 °F, débranchez immédiatement la batterie et consultez le distributeur.



**Cancer et troubles de la reproduction – Voir [www.P65Warnings.ca.gov](http://www.P65Warnings.ca.gov) pour plus de détails.**

### **DISCLAIMER**

EG4® se réserve le droit de modifier le contenu de ce document à tout moment sans préavis. Veuillez consulter [www.eg4electronics.com](http://www.eg4electronics.com) pour la version la plus récente de nos manuels/fiches techniques.

## 4. INSTALLING THE BATTERY

When installing multiple batteries or adding a battery to an existing rack, please ensure each battery is charged individually to 100% before paralleling them together. This step is crucial to optimize battery performance and ensure proper operation.

### 4.1 BATTERY DIAGRAM (NO DIPS)

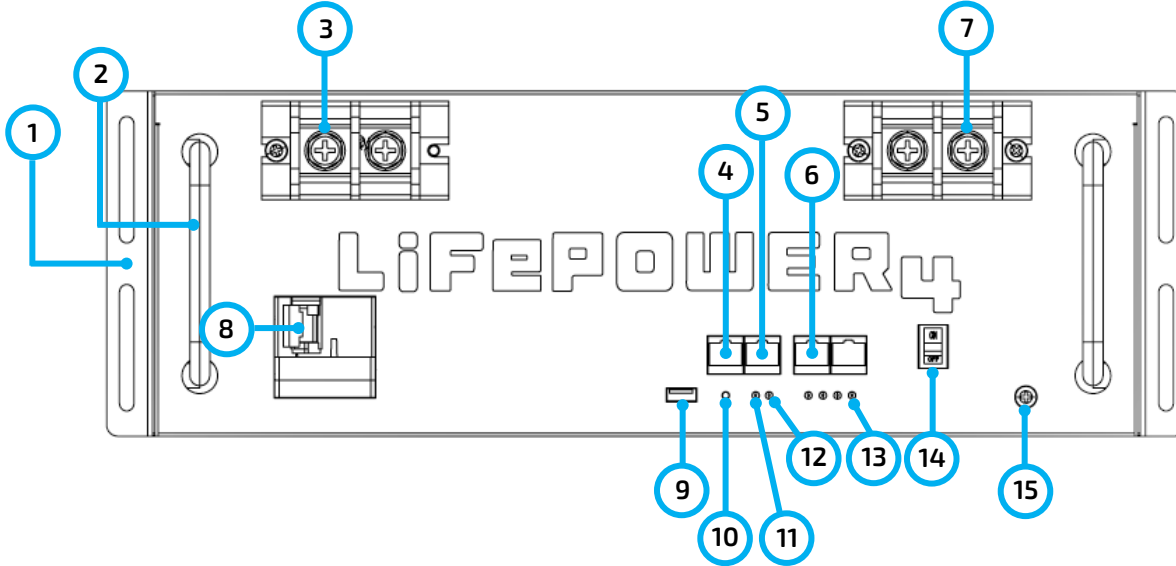

NO.	ITEM	DESCRIPTION	REMARKS
1	Rack mount ear	For battery rack mounting	Secures the battery to the rack
2	Handle	For carrying/handling battery	-
3	Positive terminal	M8 bolt (x2)	-
4	CAN	CAN communication interface	Pin 4 – CAN_H Pin 5 – CAN_L
5	RS485	RS485 communication interface	Pin 1 & Pin 8 – RS485_B Pin 2 & Pin 7 – RS485_A
6	Battery Communications	Parallel battery communication port	Used for closed-loop communication
7	Negative terminal	M8 bolt (x2)	-
8	Breaker	Circuit breaker	DC Output
9	USB Port	Reserved	-
10	Reset	Emergency Reset	-
11	ALM	Alarm LED Display	-
12	RUN	Run LED Display	-
13	SOC	State Of Charge Display	LEDs indicate charge level
14	ON/OFF Switch	Turn BMS on/off	-
15	GND	Ground connection for safety	-

## 4.2 BATTERY DIAGRAM (WITH DIPS)

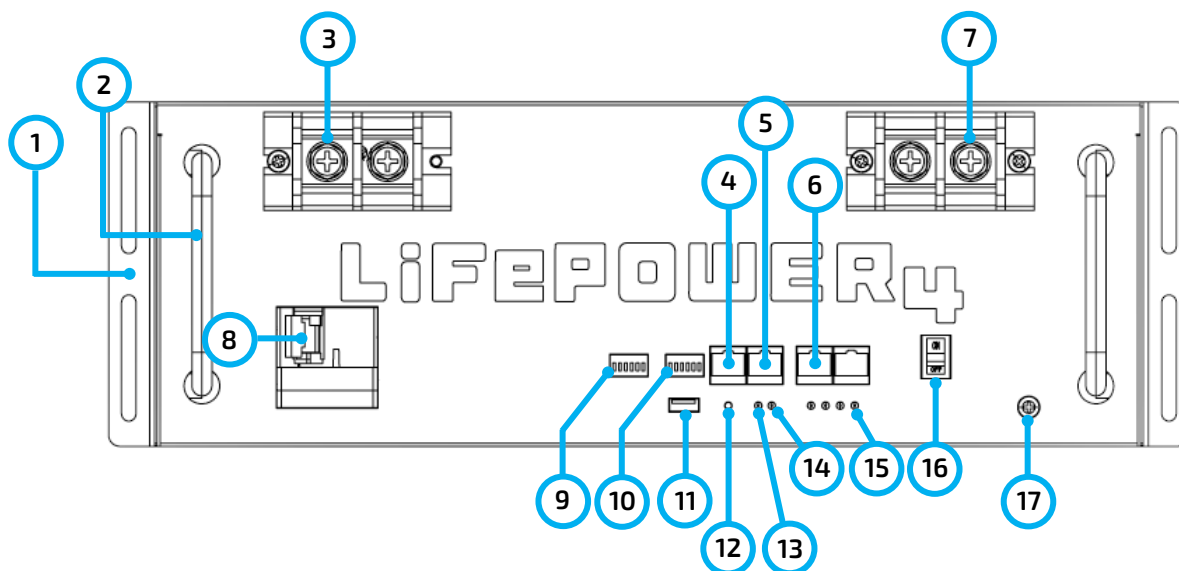

NO.	ITEM	DESCRIPTION	REMARKS
1	Rack mount ear	For battery rack mounting	Secures the battery to the rack
2	Handle	For carrying/handling battery	-
3	Positive terminal	M8 bolt (x2)	-
4	CAN	CAN communication interface	Pin 4 – CAN_H Pin 5 – CAN_L
5	RS485	RS485 communication interface	Pin 1 & Pin 8 – RS485_B Pin 2 & Pin 7 – RS485_A
6	Battery Communications	Parallel battery communication port	Used for closed-loop communication
7	Negative terminal	M8 bolt (x2)	-
8	Breaker	Circuit breaker	DC Output
9	Protocol DIP Switch	Select inverter protocol	6 position DIP switch
10	Battery ID DIP Switch	ID for battery arrangement	6 position DIP switch, can support 64 in parallel
11	USB Port	Reserved	-
12	Reset	Emergency Reset	-
13	ALM	Alarm LED Display	-
14	RUN	Run LED Display	-
15	SOC	State Of Charge Display	LEDs indicate charge level
16	ON/OFF Switch	Turn BMS on/off	-
17	GND	Ground connection for safety	-

## 4.3 PRE-WIRE STEPS AND WIRING

The battery will come with 1 set of 4 AWG power cables. Please refer to the inverter documentation that the battery will be connected to for torque specs and wire sizing needs for specific use cases.



### NOTE:

Where ambient temperature is above 86°F (30°C), cable size must be increased according to NEC 310. **The 4 AWG cable included in the package is intended only for the connection from the module to an EG4 battery rack busbar.**



### CAUTION:

*The battery can charge/discharge up to 100A before the BMS shuts off the pack. Ensure the inverter is configured to handle this high of a current and size all wires accordingly! Refer to an NEC approved ampacity chart or consult with the installer or a solar electrician for more information.*



### DANGER:

***No connections should be made until the proper polarity of the cables have been confirmed between the battery and inverter!***

## 4.4 MULTIMETER TESTING AND WIRING

Follow the steps outlined below to both test the inputs and wire the battery pack to the system. Refer to the system's user manual for specific torque values. If using non-EG4 inverters, please refer to the appropriate manufacturer user manual and/or spec sheet.

1. Ensure all circuit breakers in the system are open (off). Using a multimeter, check for voltage at all available disconnects and lines. Once no voltage is confirmed, proceed to the next step.
2. Connect the included set of 4 AWG to the battery's positive and negative terminals, respectively.
3. If applicable, route the battery power cables through the conduit box to the inverter **before making any connections!**
4. Ensure proper polarity of cables. Once confirmed, proceed to the next step.
5. Install the positive battery cable to the inverter's positive battery terminals following proper torque values.
6. Install the negative battery cable to the inverter's negative battery terminals following proper torque values.



### NOTE:

If installing the battery pack with the optional conduit box, secure the conduit fittings to the enclosure using the counter nuts after step 2.



### IMPORTANT:

Ensure a minimum installation space volume of 55 m<sup>3</sup>, if not ventilated. This ensures flammable gas stays below 25% of the Lower Flammable Limit (LFL) in case of thermal runaway. Room volume is based on released gases and the number of battery cells affected during testing. Adding more EG4® LifePower4 48V V2 & V3 batteries does not require a larger installation location, as tests showed no propagation between units. Required installation volume may be reduced with proper ventilation per code and jurisdictional requirements.

## 5. EXAMPLE CONNECTION CONFIGURATIONS



### NOTE:

The image below represents 6 EG4® LifePower4 V2 batteries with an EG4 Welded Indoor Cabinet. When installing multiple batteries or adding a battery to an existing rack, please ensure each battery is charged individually to 100% before paralleling them together. This step is crucial to optimize battery performance and ensure proper operation.

1. Insert the battery into the rack slot, beginning with the bottom slot and progressing upward. Slide in until the battery is firmly seated in the rack.
2. **Use the included 4 AWG power cable to connect each battery to the busbar.**
3. **DO NOT** finger tighten the battery or busbar terminal bolts. The battery bolts require a certain torque [60 in-lbs. (6.8Nm)] to ensure they do not loosen during operation. Failure to properly tighten the terminal bolts can result in serious damage and will void the warranty.
4. Clearly identify the location of the batteries positive and negative terminals—red to the positive terminal and black to the negative terminal. Then connect to the inverters positive and negative terminals.

### Grounding

Attach a grounding wire from the rack/cabinet to an equipment grounding conductor, then terminate the EGC at a grounding electrode.



### WARNING:

**Do not ground rack/cabinet or door to negative or positive bus bars!**

*In this image, there are 6 LifePower4 V2 100Ah batteries wired in parallel. This battery bank still maintains the appropriate 48V needed for a system. However, the amp hour rating of this bank has increased to 600Ah. In addition, the potential output amperage of the rack increases.*



### NOTE:

Use the included battery cables and/or size the battery cables appropriately! Refer to an NEC approved ampacity chart for specifications.



### NOTE:

EG4 recommends using a **properly sized** (amp rated) busbar to parallel batteries together. Paralleling via the battery terminals will cause inconsistent charging and discharging issues in the bank.

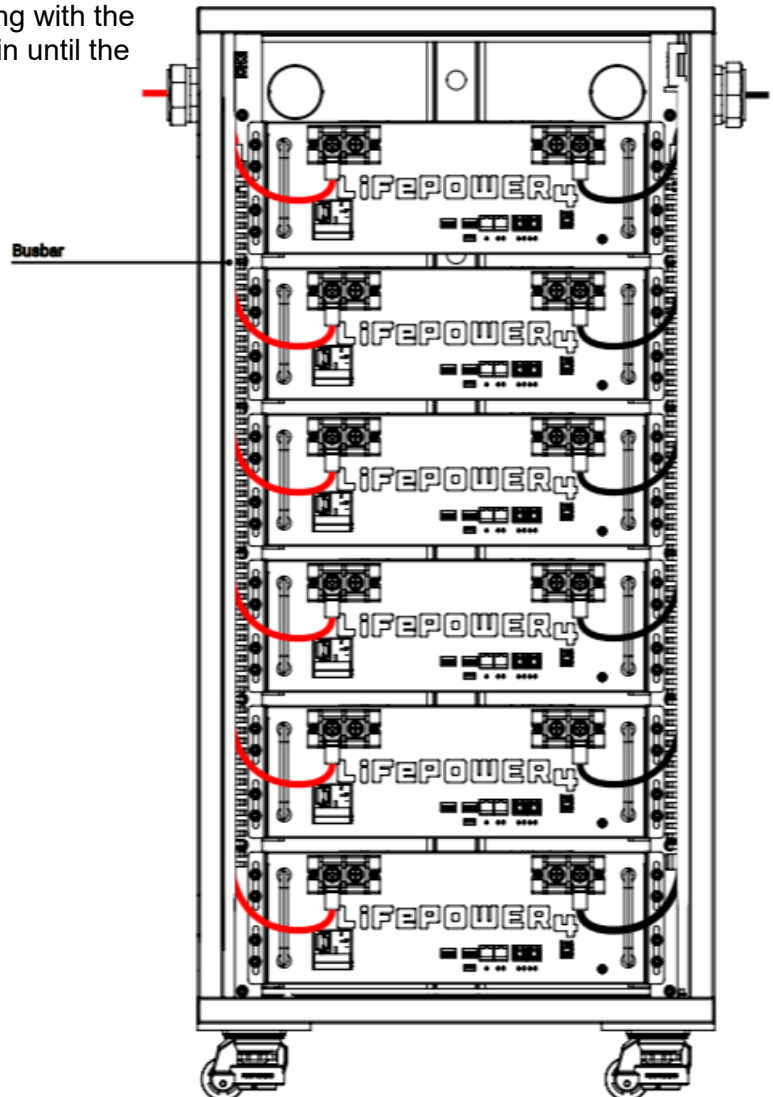

## 5.1 ADDITIONAL CONFIGURATIONS WITH EG4 BATTERY MODELS

EG4® LifePower4 batteries can communicate with all EG4 48V server rack modules.



### NOTE:

When installing multiple batteries or adding a battery to an existing rack, please ensure each battery is charged individually to 100% before paralleling them together. This step is crucial to optimize battery performance and ensure proper operation.

If communicating multiple EG4 batteries together, the *Multipack firmware* will need to be used via an RS485 Update. For the example below, all batteries will need to be updated **EXCEPT** the EG4 LifePower V2.

*RSD will be disabled on the battery models that have this feature when using the multipack firmware.*

Please visit <https://eq4electronics.com/resources/downloads> for the *Multipack firmware*.

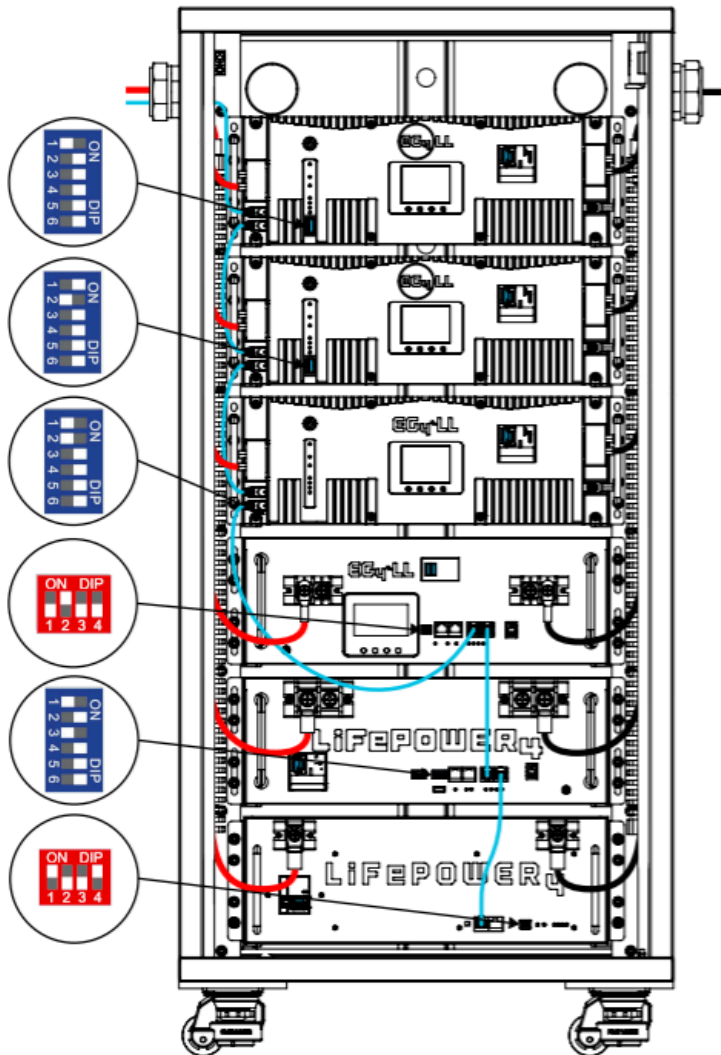

1. **Always use the newest model of LL** at the top of the rack as this will need to be the battery that communicates with the system. This battery is also known as the master and will need to have ID number 1.
2. When installing the batteries, ensure that the same models are grouped together in the bank. This allows for communication to flow between the batteries consistently.
3. After installing the batteries into the rack, refer to the DIP Switch ID table to assign the address code of the bank in numerical order, beginning with the master and progressing among the different models.

The image on the left shows a bank with the following EG4 modules:

1. **LL-S (6 DIP) [ID-1]:**  
Requires Multipack Firmware.
2. **LL-V2 (6 DIP) [ID-2]:**  
Requires Multipack Firmware.
3. **LL-V2 (4 DIP) [ID-3]:**  
Requires Multipack Firmware.
4. **LL-V1 [ID-4]:**  
Requires Multipack Firmware.
5. **LifePower4 V2 [ID-5]:**  
No firmware update needed. Set the Inverter Protocol dipswitch set to the "Simplified Link Protocol." See Section 7.
6. **LifePower4 [ID-6]:**  
Requires latest firmware.

## PARALLEL CABLES NEEDED



**NOTE:** If utilizing an external E-Stop switch on the LifePower4 V2 battery, the following pinout information stays relevant to the function. Once the E-Stop engages, all batteries in the bank will initiate the stop function.

To successfully communicate between each model of battery, a standard Cat5e (or higher) cable will need to be connected between each battery.

### BATTERY-TO-BATTERY CABLE PINOUT

The pins utilized for battery-to-battery communication are as follows:

LL-V1/LifePower4	
Pin	Description
7	RS485-B
8	RS485-A

LL-S/LL-V2 (4&6 DIP)	
Pin	Description
7	RS485-B
8	RS485-A

The battery will only send a transmit/receive signal over these two pins. Ensure the battery-to-battery communication cable is only utilizing pins 7 & 8.



**NOTE:** When using LL-V1 and LifePower4 V1 batteries in communications with the LifePower4 V2, ensure the communications cable between the LL-V2 and all older model batteries down are pinned to this standard. If there are extra pins populated, the LifePower4 V2 will trip its breaker if it receives a signal from pins 3 or 6 along with all other batteries in this parallel configuration.

## FIRMWARE UPDATES

Visit <https://eg4electronics.com/resources/downloads> to get the latest version of the software. The file can be located on the downloads page underneath the product in question.

Once the file has been downloaded, unzip the file. Once the file is unzipped, refer to the included "Connection guide for BMS Tools V1.0.pdf" for an extensive walkthrough to set up BMS Tools.

If confirmation of the port numbers for battery to PC communications is needed, please consult the following section.

### UPDATE CABLES NEEDED

Each battery requires the same RS485 cable to apply the firmware updates. Please refer to the table below for the pinout description.

Ensure all batteries' firmware matches the numbers listed below for seamless communication.

Pin	Description
1	RS485-B
2	RS485-A

## MULTIPACK FIRMWARE VERSIONS NEEDED

Listed below are the multipack firmware version numbers that need to be used for each battery type:

1. EG4 LL V2/S (ID:6) 51.2V 100ah: Z02T12
2. EG4 LL V2 (ID:4) 51.2V 100ah: Z01T16
3. EG4 LL V1 51.2V 100ah: V15P15
4. LifePower4 51.2V 100ah: V3.37 or V2.16

## 6. BATTERY COMMUNICATIONS

Each EG4 Electronics® battery is designed with the end-user in mind, displaying as much information as possible in the simplest manner. EG4 Electronics includes the option of connecting the battery to PC software to monitor the module status. This enables users to monitor and comprehend the battery's performance and to troubleshoot any issues that may occur.

*When a single battery is used, it will communicate directly with the system via the RS485 or CAN port. The battery will connect via a properly pinned battery communications cable (included).*

**The communication cable from battery to battery is a standard CAT5 cable. If the battery to inverter communication cable is not long enough to span the distance from inverter to master battery, scan the QR code below to access the Communication Cable Pinout Table in Section 10.6 of the Quick Start Guide.**



### **WARNING:**

Make sure to install the communication cables into their respective ports! Improper installation may lead to component damage!

EG4 recommends double checking all points of connection before introducing power to the system to mitigate any potential issues.

## 6.1 AUTO-ID BMS PROTOCOL FEATURE

The EG4® LifePower4 V2 48V battery comes in two designs. One with DIP switches and one without. The newest design comes with a new Auto-ID feature.

At its core, Auto-ID handles two key functions: protocol detection and ID assignment. When the first battery is powered on and connected, the BMS checks for inverter communication signals and automatically selects the proper protocol. For example, when paired with the EG4 FlexBOSS21 inverter, the BMS would set to the EG4/Lux protocol without requiring any user configuration.

At the same time, the system assigns the first battery as ID:1 (master). Additional Auto-ID batteries added to the chain automatically receive unique IDs in the proper sequence. This means that installers no longer need to set the master unit manually or configure each subsequent battery; the process is handled internally by the BMS. Auto-ID BMS Protocol is only available on EG4 batteries that have no DIP switches. Scan the QR code below for more information regarding Auto-ID BMS Protocol features.



## 6.2 AUTO-ID SETUP



### **NOTE:**

The 120Ω terminating resistor is used for establishing battery to battery closed-loop communication. The inverters listed below are capable of closed-loop communication with the battery. All other inverters will not support closed-loop communications with EG4® WallMount 314Ah Indoor batteries.

1. Ensure all battery breakers in the parallel battery bank are in the OFF position.
2. Verify all physical connections have been placed securely and correctly according to the wiring diagrams for communication found in section 6.3.
3. Install a 120Ω terminating resistor in Comm1 of the master battery and Comm2 of the last battery in the parallel battery bank.
4. Press the BMS On/Off button to turn on the BMS on the master battery. This will allow the Auto-ID feature of the master battery to assign battery ID's to the slave batteries as they are powered on.
5. Power on each remaining battery one at a time by pressing the BMS On/Off button, starting with the battery directly after the master and continuing down the line.
6. The batteries should have successfully been assigned ID's automatically. Confirm with all batteries and inverters that no faults or protections have been triggered after powering on the batteries.

### **RS485 Communication Compatible Inverters:**

EG4  
Growatt  
Schneider  
Voltronic

### **CAN Communication Compatible Inverters:**

EG4  
Growatt  
Sol-Ark  
Deye  
Megarevo  
Luxpower  
Pylon  
Victron  
Solis  
Sunny Boy

## 6.3 BMS COMMUNICATION WIRING

The following diagram shows the battery communication cable wiring when using strictly Auto-ID BMS Protocol for the no DIP LifePower4 V2 batteries.

Follow the guidelines listed below:

1. Starting from the last battery in the stack, use the included communication cables to parallel the batteries together. Plug the cable into the Comm Port 1 on the last battery, and daisy chain up to Comm Port 2 on the next battery up and repeat until the master battery is reached.
2. Depending on whether the system uses CAN or RS485 communications, plug the battery to inverter communication cable in either the CAN or RS485 port on the master battery and then connect the cable to the respective battery communication port on the inverter.
3. Use the included  $120\Omega$  terminating resistor to “close” the communication loop by plugging in to the “Batt Comm 1” port on the master battery.
4. Use the included  $120\Omega$  terminating resistor to “close” the communication loop by plugging in to the “Batt Comm 2” port on the last battery in the stack.

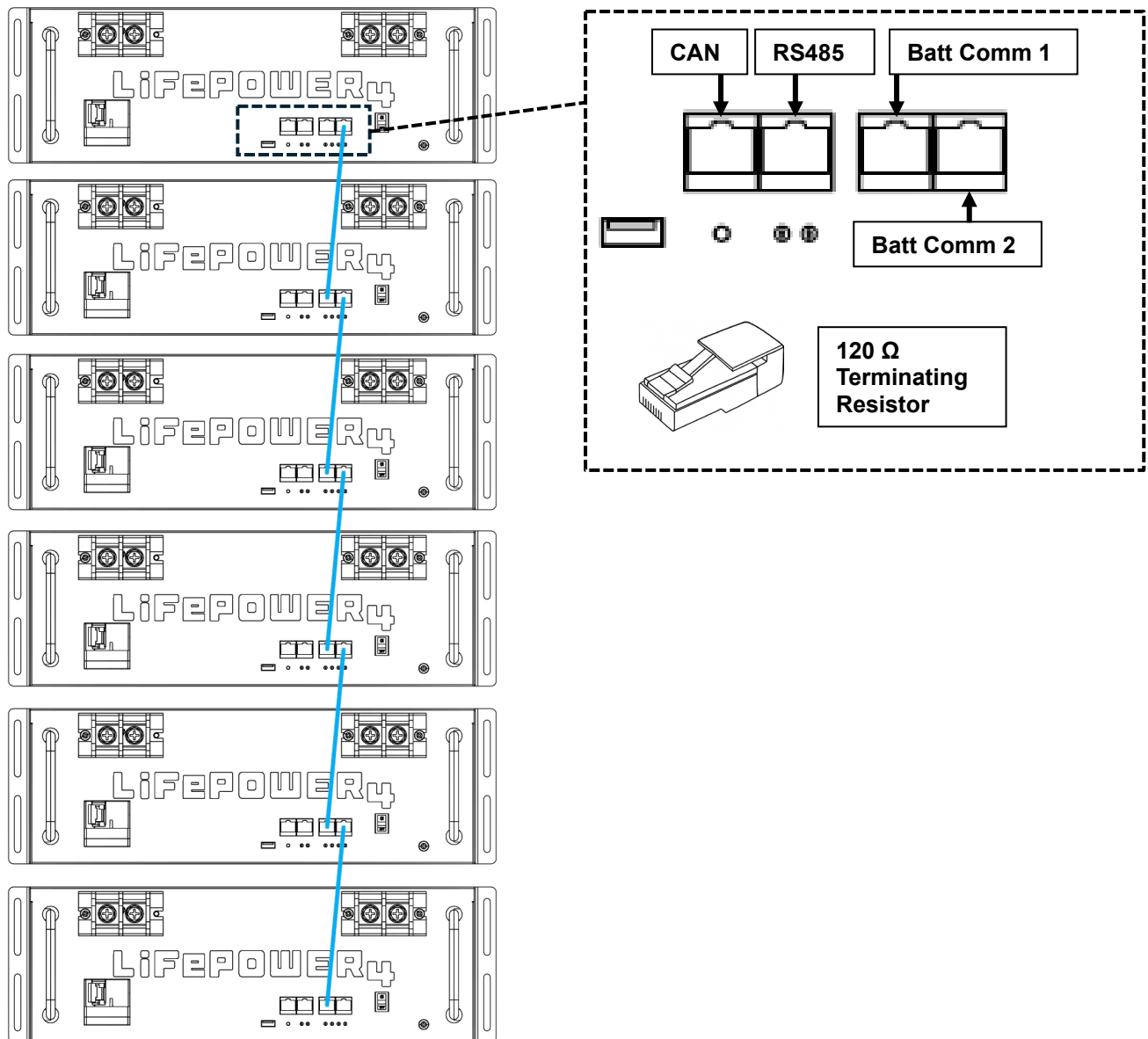

## 6.4 MULTIPLE BATTERIES IN PARALLEL (NO DIPS)

1. Ensure all battery breakers and BMS are OFF.
2. Establish communication between the batteries via the “Battery-Comm” ports. Starting with the bottom battery and working all the way to the top battery. (See Section 10.3 for communication cable installation)



### NOTE:

When using EG4® LifePower4 V2 no DIP with the Auto-ID BMS Protocol as the “Master”, all other batteries DIPs will have to be set manually in the correct sequence before turning on the system. See image below for reference.

3. The mastery battery (referred to as the host) will connect to the system via communication cable using the RS485 or CAN port. (See image below)
4. Power on each battery breaker and BMS ON switch one at a time beginning with the host battery.



### NOTE:

When using closed-loop communication, connect the 120Ω RJ45 terminating resistor to the left Battery-Comm port on the master battery with. Verify this is connected to the correct port. Connecting to the wrong port may cause damage to the system and attached components.

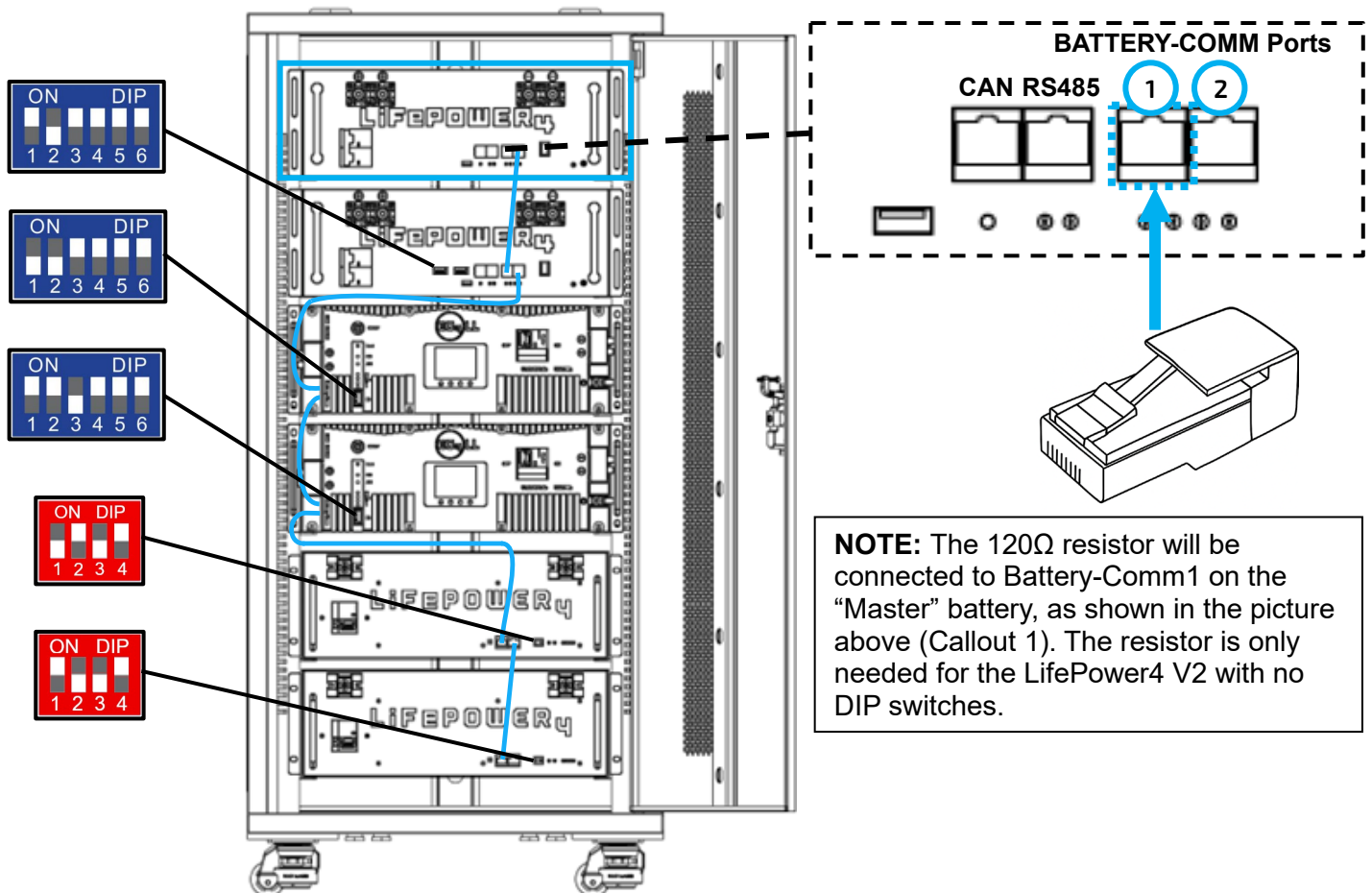

**NOTE:** The 120Ω resistor will be connected to Battery-Comm1 on the “Master” battery, as shown in the picture above (Callout 1). The resistor is only needed for the LifePower4 V2 with no DIP switches.





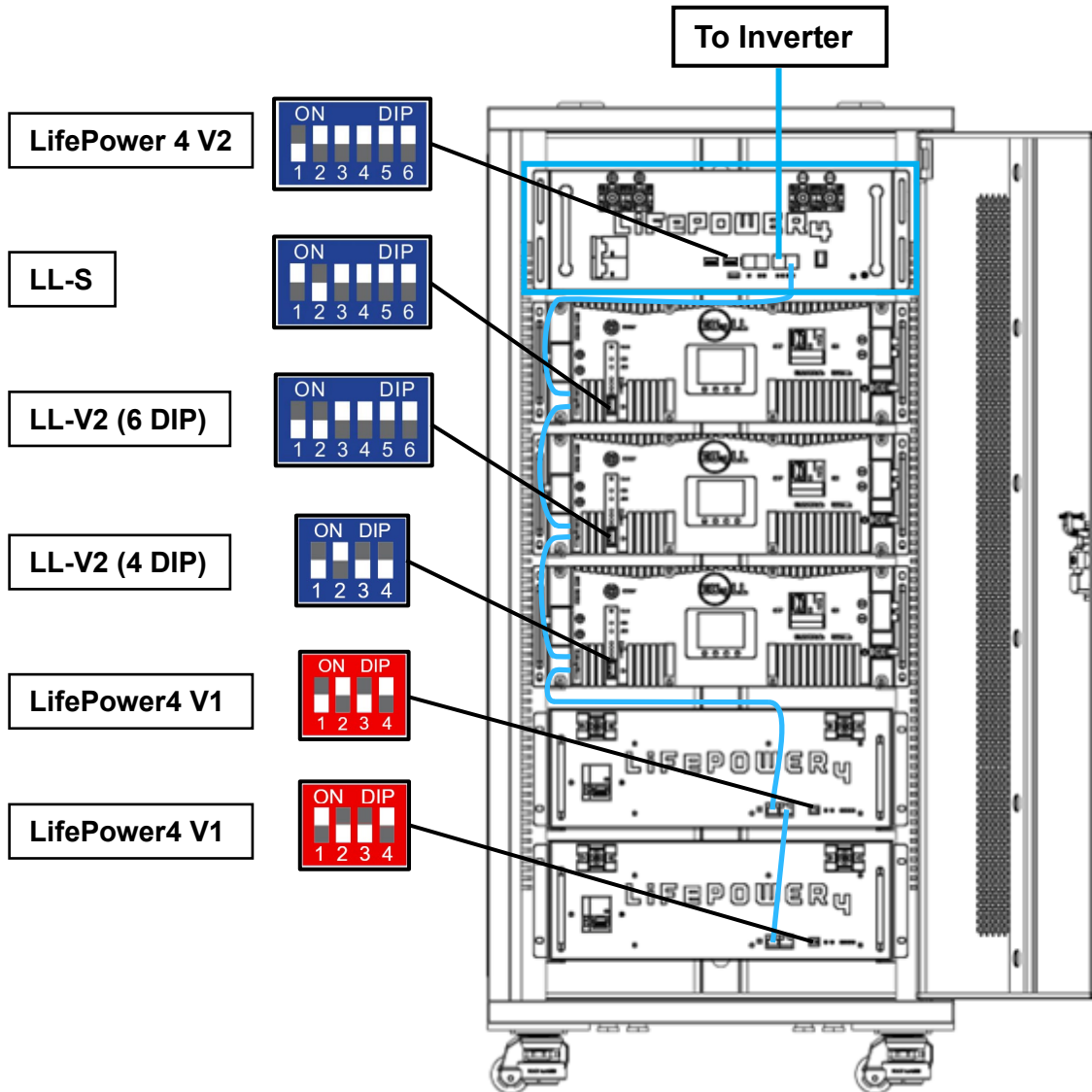

## 6.5 MULTIPLE BATTERIES IN PARALLEL (WITH DIPS)

1. Ensure all battery breakers and BMS are OFF.
2. Set the address code of each battery according to the DIP Switch ID Table in the respective battery's user manual, making sure there are no duplicate addresses.
3. Establish communication between the batteries via the "Battery-Comm" ports. Starting with the bottom battery and working all the way to the top battery.
4. The battery with DIP Switch ID 1 (referred to as the host) connects to the system via communication cable using the RS485 or CAN port. (See image below)
5. Power on each battery breaker and BMS ON switch one at a time beginning with the host battery.

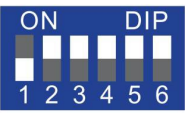
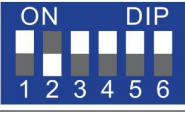
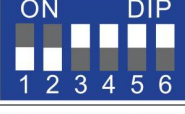
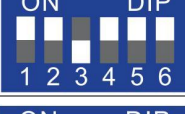

## 7. PROTOCOL SELECT

### 7.1 PROTOCOL ID DIP SWITCH

CODE	DIP SWITCH POSITION	BRAND	COMMUNICATIONS
1		EG4/Lux	CAN
2		Growatt	CAN
3		Sol-Ark	CAN
4		Deye	CAN
5		Megarevo	CAN
6		Victron	CAN
7		Luxpower	CAN
8		SMA	CAN
<p><b>Note:</b> Protocol DIP switch 6 will be used to allow battery communication to the other batteries depending on which battery version you have.</p>			
9		Complete LINK protocol	In the "ON" position, this allows the battery to communicate with the Indoor and Outdoor WallMount and version 2 LL's and original batteries with the Multipack firmware.
10		Simplified LINK protocol	In the "OFF" position, this allows the battery to communicate with version 1 LL's and original LifePower4 with the Multipack firmware.



**NOTE:** The Complete Link Protocol and the Simplified Link Protocol will **ONLY** work with CAN communication, not RS485.

## 7.2 RS485 PROTOCOL AUTODETECTION



### NOTE:

When using RS485 communications, the battery will auto detect the inverter protocol being used.

CODE	DIP SWITCH POSITION	BRAND	COMMUNICATIONS
64		EG4	RS485
64		Growatt	RS485
64		Schneider	RS485

**Note:** Confirm that the RS485 cable being used is pinned correctly in respect to the inverter being used.

PIN	DESCRIPTION
1	RS485-B
2	RS485-A



**NOTE:** BMS ON/OFF switch will have to be powered off and back on for the address changes to take effect and reengage.

## 8. EMERGENCY STOP (RSD, ESS DISCONNECT)



### WARNING

*Make sure to install the communication cables into their respective ports! Improper installation may lead to component damage!*

*EG4 recommends double checking all points of connection before introducing power to the system to mitigate any potential issues.*

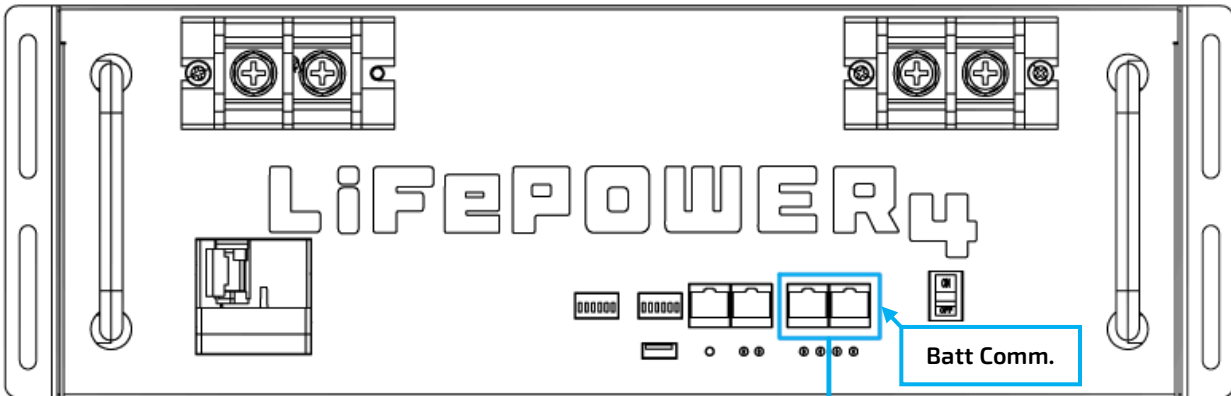

The optional E-Stop Switch disconnect can be used to shut down all batteries and inverters (if equipped) with the push of a button.

When paralleling multiple batteries, the E-Stop Switch only needs to have connections made with the master battery.

This integrated safety feature ties directly into the battery communication system via an open Battery-Comm port using a standard Cat-5/6 ethernet cable.

Pins 3 & 6 are used to communicate the emergency stop information to the batteries once the stop button is pressed.

If the inverter is equipped with rapid shut down (RSD) capabilities, the emergency stop feature can be used to initiate this function, eliminating the need for an external RSD switch. Check with the local AHJ and NEC code for compliance.

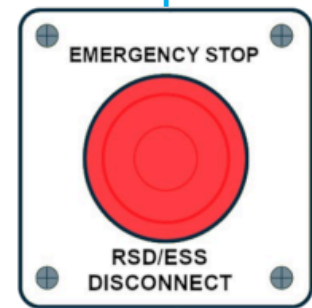

To inverter, RSD Initiator, or ESS Disconnect (inverter recommended if compatible with inverter's RSD system) Normally Open (NO) or Normally Closed (NC) contacts depending on inverter.

## 9. WARRANTY INFORMATION

For information regarding warranty registration on EG4® Electronics products, please navigate to <https://eg4electronics.com/warranty/> and select the corresponding product to begin the registration process.

## 10. CHANGELOG

### Version 1.1.7

- Added spacing volume to section 4.4

### Version 1.1.6

- Updated section 6 to section 7 on page 11
- Updated verbiage in quick part note to have “of the Quick Start Guide”
- Added Quick Start Guide QR code to page 13
- Updated section 8.1 to section 6.3 on page 14

### Version 1.1.5

- Modified firmware versions needed for multi-pack communications
- Modified inverter protocol DIP selection information
- Updated battery image to reflect latest model
- Added information regarding Auto-ID BMS Protocol upgrade
- Added new section for BMS communication for the new BMS Auto-ID feature, section 6.1.

### Version 1.1.4

- Added operating altitude in environmental parameters
- Modified recommended charging current from 30A to 50A
- Added recommended discharging current of 50A
- Modified temperature range for charge range, discharge range, and storage range
- Modified PCB Temp protection from >221°F (>105°C) to >230°F (>110°C)

### Version 1.1.3

- Added French warnings/danger section
- Modified over charge current delay from 20s to 10s
- Modified over discharge current delay from 30s to 10s

### Version 1.1.2

- Modified Safety Sheet information in Section 2.
- Added cETL logo to cover page.
- Modified warranty in section 8
- Added communication error in Section 5.3

### Version 1.1.1

- Modified SOC cutoff row to also show Voltage cut-off

### Version 1.1

- Modified spec sheet to show 20% recommended battery cut-off
- Added RS485 Protocol Autodetection Section 6.2

### Version 1.0

- First version release



## CONTACT US

[support@eg4electronics.com](mailto:support@eg4electronics.com)

(903) 609-1988

[www.eg4electronics.com](http://www.eg4electronics.com)