

EG4[®] MINI-SPLIT OUTDOOR WALL BRACKET

QUICK START GUIDE

This guide has been created to give the end-user a simple and efficient way to install the EG4 Mini-Split outdoor wall bracket.



TABLE OF CONTENTS

1.	OVERVIEW.....	1
2.	RECOMMENDED TOOLS.....	1
3.	PACKING LIST.....	1
4.	INSTALLATION STEPS.....	2
4.1	IDENTIFY THE INSTALLATION LOCATION.....	2
4.2	CHECK WALL STRENGTH.....	3
4.3	INSTALL THE CROSSBAR.....	3
4.4	PREPARE THE BRACKETS.....	4
4.5	ATTACH THE BRACKETS.....	4
4.6	INSTALL OUTDOOR UNIT ON BRACKETS.....	5
4.7	VALIDATE INSTALLATION.....	5

1. OVERVIEW

The EG4 Mini-Split outdoor wall mount bracket has been made to withstand a maximum weight of 352 lbs. and supports all EG4 outdoor units. The bracket is made of powder-coated metal to withstand extreme weather keeping the outdoor unit off the ground and protected from ground threats, such as snow or rodents.

The bracket also includes a level in the horizontal crossbar which helps to precisely install the support bar. The included mounting hardware is designed to support most installations.

2. RECOMMENDED TOOLS

- A. Tape Measure
- B. Drill Motor
- C. Drill Bit Set
- D. Hex Nut Driver Bits

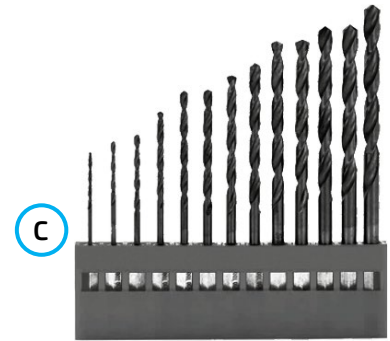
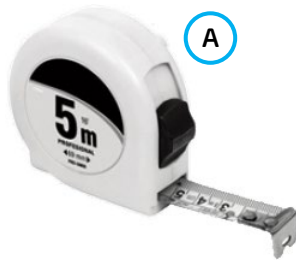

3. PACKING LIST

- A. Parts Bag – Qty 1
- B. Crossbar – Qty 1
- C. Vertical Brackets – Qty 2
- D. Horizontal Brackets – Qty 2

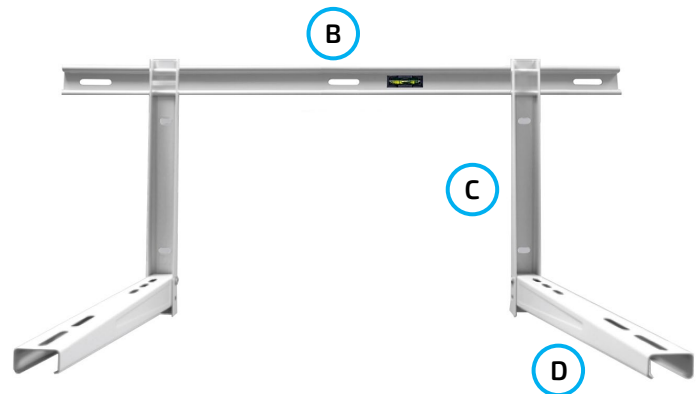

4. INSTALLATION STEPS

This guide provides the necessary steps to properly install the Outdoor Wall Bracket.



IMPORTANT: The Outdoor Wall Bracket should be installed with the outdoor unit securely fastened to the bracket before attaching the refrigerant line set as well as any required electrical cables. Attaching the line set and electrical cables to a secure unit will assist in protecting the line set and cables from over-flexing and possible damage due to unexpected movement of the unit.

4.1 IDENTIFY THE INSTALLATION LOCATION

Before installing the unit, ensure a suitable location is identified following the manufacturer's space requirements for the outdoor unit. Take into account adequate height above the ground to prevent contact with external elements like water, snow, mud, and debris.

The following installation guidelines meet the installation requirements for EG4 Mini-Split outdoor units:

- Meets all spatial requirements shown in Installation Space Requirements
- Good air circulation and ventilation
- Firm and solid location that can support the unit and mitigate vibration
- Noise from the unit will not disturb others
- Protected from prolonged periods of direct sunlight or rain
- Where snowfall is anticipated, raise the unit above the base pad to prevent ice buildup coil damage
- Mount the unit high enough to be above the average accumulated area snowfall. The minimum height must be 18 inches
- Mount the Mini-Split Outdoor Wall Bracket to a stable, non-moving structure to help mitigate excess vibrations

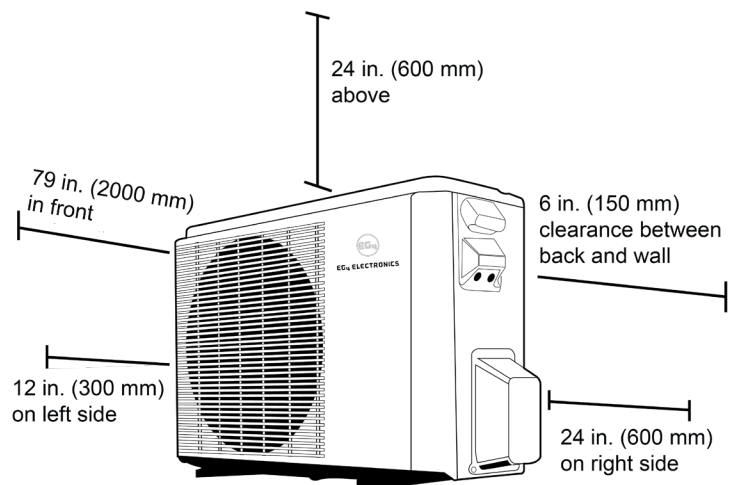

DO NOT INSTALL

- Near an obstacle that will block air inlets and outlets
- Near a public street, crowded areas, or where noise from the unit will disturb others
- Near animals or plants that will be harmed by hot air discharge
- Near any source of combustible gas or in a location that is exposed to large amounts of dust
- In a location exposed to excessive amounts of salty air

4.2 CHECK WALL STRENGTH

Verify that the chosen wall can adequately support the weight of the unit. Ensure it is structurally sound. When mounting the wall bracket on concrete or brick, use the included wall anchors. When mounting the bracket on other substrates (i.e. wood, vinyl, hardy board, stucco, etc), locate wall studs to support the weight of the bracket and outdoor unit. Wall anchor expanders may be used if supported by the wall material (siding).



NOTE: The 3 holes in the crossbar bracket have a 14-inch on-center spacing and will not properly align to common 16-inch or 24-inch on-center studs as shown by the measurements below.

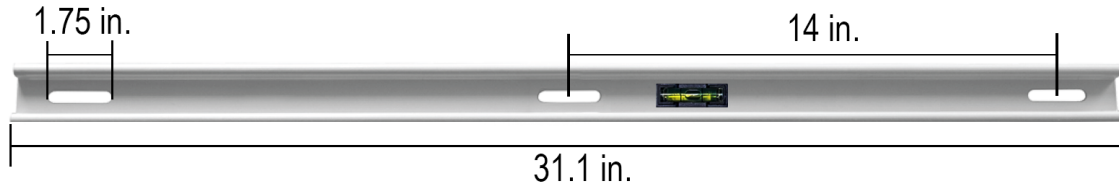

CAUTION: The Outdoor Mounting Bracket must be properly installed to support the weight of the Outdoor Mini-Split unit. Improper installation could cause damage to the unit and/or exterior siding. Consult a licensed contractor if there is any concern with the installation requirements.

The recommended wall mounting procedures and hole placement are listed in the chart below.

Brick or Concrete	16" or 24" on center wall studs
Mark and drill all 3 bracket holes. Use the supplied wall anchors for bracket attachment.	Attach the crossbar center hole to a stud. Use appropriate wall anchors (not included) in the two outside holes. Wall blocking may be required.

4.3 INSTALL THE CROSSBAR

- a. Level the crossbar, using the built-in level, at the designated installation location.



- b. Mark at least two holes in preparation for pre-drilling. See the previous section "Checking Wall Strength" for more details on proper hole placement.
- c. Carefully drill the marked holes using the proper size drill bit for the anchor expanders or screws if mounting into a stud.
- d. If wall anchor expanders are used, insert them into the holes, ensuring they are suitable for the wall material and weight expectations.
- e. Secure the bracket to the wall using the proper screws.

4.4 PREPARE THE BRACKETS

- Prepare the brackets by expanding the bottom bracket to 90°.
- Insert the security pin in the bottom hole to keep the horizontal brackets from folding closed.
- Screw in the back levelers on the brackets.



4.5 ATTACH THE BRACKETS

- Slide the brackets onto the crossbar so they evenly distribute the weight along the crossbar and mounting locations.



- Measure the distance between the base feet of the Condensing Unit. The measurements for the outdoor units are listed below.

EG4 9K and 12K BTU Units	A	21.2 in. (539mm)	
	B	12.9 in. (327mm)	
EG4 24K BTU Unit	A	25.0 in. (635mm)	
	B	13.3 in. (337mm)	

- d. Set the distance between the brackets to match the distance between the feet of the outdoor unit (measurement A). The distance between the brackets should be verified from center hole to center hole as shown below.

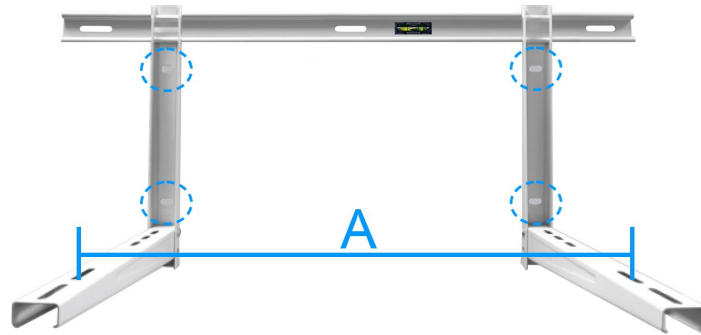

- e. If needed, attach additional wall anchors or screws (circled above) into the vertical brackets to support the required load capacity.
- f. Verify the brackets are securely in place and ready for the weight of the outdoor unit.

4.6 INSTALL OUTDOOR UNIT ON BRACKETS

- a. Place the outdoor unit onto the brackets. Be sure to follow proper clearance requirements between the back of the unit and the wall.
- b. Insert rubber pads below the feet of the outdoor unit.
- c. Use the provided nuts and bolts to fasten the unit securely to the brackets.

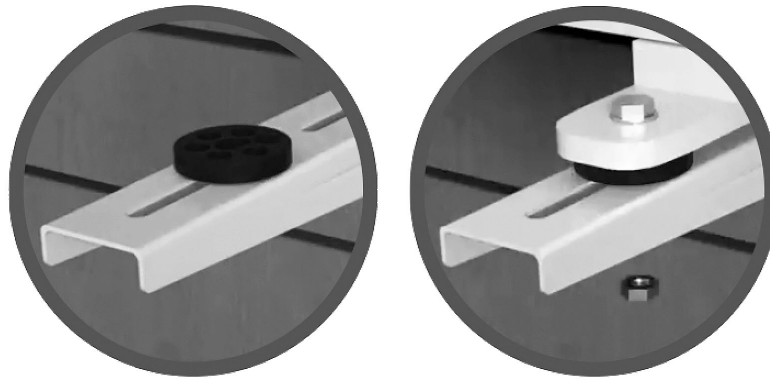

4.7 VALIDATE INSTALLATION

- a. Verify the outdoor unit is securely fastened to the brackets.
- b. Verify the unit is level side to side and front to back to ensure proper condensation drainage when running in heat pump mode.
- c. Verify proper clearances are met on all sides of the unit.
- d. The outdoor unit is now ready for the attachment of the refrigerant line set and wiring.



CONTACT US

support@eg4electronics.com

(903) 609-1988

www.eg4electronics.com