

EG4® 12kPV HYBRID INVERTER

CONNECTIONS & PARALLELING GUIDE

This document contains information to guide the end-user through the connections and overview for both inverter and battery paralleling.



TABLE OF CONTENTS

1.	TECHNICAL SPECIFICATIONS	1
2.	INVERTER SAFETY	3
2.1	SAFETY INSTRUCTIONS.....	3
2.2	IMPORTANT SAFETY NOTIFICATIONS	3
3.	SÉCURITÉ DE L'ONDULEUR.....	5
3.1	INSTRUCTIONS DE SÉCURITÉ	5
3.2	NOTIFICATIONS DE SÉCURITÉ IMPORTANTES.....	5
4.	CABLE BOX KNOCKOUTS	7
5.	PV CONNECTION.....	8
5.1	CONNECTING PV TO THE INVERTER	8
5.2	PV WIRING INSTRUCTIONS.....	9
6.	BATTERY CONNECTION	11
6.1	BATTERY CABLE CONNECTION.....	11
6.2	LITHIUM BATTERY COMMUNICATIONS	12
7.	AC CONNECTION.....	12
7.1	STEPS FOR AC CONNECTION.....	13
7.2	CURRENT TRANSFORMER (CT) CONNECTION	14
7.3	OFF-GRID CONNECTION	16
8.	GENERATOR CONNECTION	16
8.1	GENERATOR SYSTEM CONNECTION	16
8.2	DRY CONTACT INFORMATION (GEN PORT)	17
8.3	GENERATOR AC CONNECTIONS	18
8.4	GENERATOR START AND STOP SETTINGS.....	19
9.	PARALLELING INFORMATION	20
9.1	PARALLEL COMMUNICATION CONNECTIONS	20
9.2	PARALLEL CONFIGURATION.....	20
10.	WARRANTY INFORMATION.....	22

1. TECHNICAL SPECIFICATIONS

AC INPUT DATA				
NOMINAL AC VOLTAGE	120/240VAC; 120/208VAC (L1/L2/N required)			
FREQUENCY	50/60Hz			
MAX. AC INPUT POWER	8000W			
MIN. GENERATOR SIZE	>5000W			
MAX. GEN GRID PASSTHROUGH CURRENT	80A 80A			
AC GRID OUTPUT DATA				
MAX. OUTPUT CURRENT	33.3A@240VAC 38.5A @208VAC			
OUTPUT VOLTAGE	120/240VAC; 120/208VAC			
NOMINAL POWER OUTPUT	8000W			
OUTPUT FREQUENCY	50/60Hz			
POWER FACTOR	0.99 @ Full Load			
REACTIVE POWER ADJUST RANGE	±0.8			
MAX CONT. LINE WATTAGE	4000W			
PEAK POWER	0.5 s	1 s	1 min	12 min
	16kW	12kW	10kW	8.8kW
OPERATING FREQUENCY	50/60Hz			
THD (V) @FULL LOAD	<3%			
TRANSFER TIME	Single			Parallel
	20 ms – Default, 10 ms – Selectable			20 ms
PV INPUT DATA				
NUMBER OF MPPTS	2			
INPUTS PER MPPT	2			
MAX. USABLE INPUT CURRENT	25/25A			
	25A per MPPT 41.6A in total			
MAX. SHORT CIRCUIT INPUT CURRENT	31/31A			
DC INPUT VOLTAGE RANGE	100-600 VDC			
UNIT STARTUP VOLTAGE	100 VDC			
MPPT OPERATING VOLTAGE RANGE	120-500 VDC			
NOMINAL MPPT VOLTAGE	360 VDC			
MAXIMUM UTILIZED SOLAR POWER	12000W			
RECOMMENDED MAXIMUM SOLAR INPUT	15000W			
EFFICIENCY				
MAXIMUM EFFICIENCY (PV TO GRID)	97.5%			
MAXIMUM EFFICIENCY (BATTERY TO GRID)	94%			
CEC WEIGHTED EFFICIENCY	96.4%			
MAXIMUM EFFICIENCY (PV TO BATTERY)	99.9%			
IDLE CONSUMPTION (STANDBY MODE)	<55W			

BATTERY DATA

COMPATIBLE BATTERY TYPES	Lead-Acid/Lithium
MAX. CHARGE/DISCHARGE CURRENT	167A @ 48 VDC
NOMINAL VOLTAGE	48 VDC
VOLTAGE RANGE	40-60 VDC (Lithium); 40-60 VDC (Lead-Acid)
RECOMMENDED BATTERY CAPACITY PER INVERTER	>200Ah

GENERAL DATA

MAX. UNITS IN PARALLEL	10
PRODUCT DIMENSIONS (H×W×D)	29.5×20.5×11.2 in (750×520×285 mm)
UNIT WEIGHT	110 lbs. (50 kg)
DESIGN TOPOLOGY	High Frequency - Transformerless
RELATIVE HUMIDITY	0-100%
OPERATING ALTITUDE	<2000m (<6561 ft)
OPERATING AMBIENT TEMPERATURE RANGE	-13°F – 140°F (-25°C – 60°C)
STORAGE AMBIENT TEMPERATURE RANGE	-13°F – 140°F (-25°C – 60°C)
NOISE EMISSION (TYPICAL)	<50 dB @ 3 ft
LOCKED ROTOR AMPS (LRA)	195A
COMMUNICATION INTERFACE	RS485/Wi-Fi/CAN
STANDARD WARRANTY*	10-year standard warranty
ENCLOSURE RATING	NEMA 4X
SAFETY FEATURES	PV Arc Fault Protection, PV Ground Fault Protection, PV Reverse Polarity Protection, Pole Sensitive Leakage Current Monitoring Unit, Surge Protection Device, integrated PV disconnect

STANDARDS AND CERTIFICATIONS

UL1741 SB

CSA C22.2#107.1:2016

CSA C22.2#330:2017 ED. 1

HECO SRD-IEEE-1547.1:2020 ED. 2

RAPID SHUT DOWN (RSD) NEC 2020:690.12

FCC PART 15, CLASS B

*For information regarding warranty registration on EG4® Electronics products, please navigate to <https://eg4electronics.com/warranty/> and select the corresponding product to begin the registration process.

2. INVERTER SAFETY

2.1 SAFETY INSTRUCTIONS

International safety regulations have been strictly observed in the design and testing of the inverter. Before beginning any work, carefully read all safety instructions, and always observe them when working on or with the inverter. The installation must follow all applicable national or local standards and regulations.

Incorrect installation may cause:

- Injury or death to the installer, operator or third party
- Damage to the inverter or other attached equipment

2.2 IMPORTANT SAFETY NOTIFICATIONS



DANGER: *Hazardous Voltage Circuits!*

There are various safety concerns that must be carefully observed before, during, and after the installation, as well as during future operation and maintenance. The following are important safety notifications for the installer and any end users of this product under normal operating conditions.

1. **Beware of high PV voltage.** Install an external DC disconnect switch or breaker and ensure it is in the “off” or “open” position before installing or working on the inverter. Use a voltmeter to confirm there is no DC voltage present to avoid electric shock.
2. **Beware of high grid voltage.** Ensure the AC switch and/or AC breaker are in the “off” or “open” position before installing or working on the inverter. Use a voltmeter to confirm there is no voltage present to avoid electric shock.
3. **Beware of high battery current.** Ensure that the battery module breakers and/or on/off switches are in the “open” or “off” position before installing or working on the inverter. Use a voltmeter to confirm there is no DC voltage present to avoid electric shock.
4. **Do not open the inverter while it is operating to avoid electric shock and damage from live voltage and current within the system.**
5. Do not make any connections or disconnections (PV, battery, grid, communication, etc.) while the inverter is operating.
6. An installer should make sure to be well protected by reasonable and professional insulative equipment [e.g., personal protective equipment (PPE)].
7. Before installing, operating, or maintaining the system, it is important to inspect all existing wiring to ensure that it meets the appropriate specifications and conditions for use.
8. Ensure that the PV, battery, and grid connections to the inverter are secure and proper to prevent damage or injuries caused by improper installation.
9. Some components of the system can be very heavy. Be sure to utilize team-lift among other safe lifting techniques throughout the installation.



WARNING: TO REDUCE THE RISK OF INJURY, READ ALL INSTRUCTIONS!

All work on this product (system design, installation, operation, setting, configuration, and maintenance) must be carried out by qualified personnel. To reduce the risk of electric shock, do not perform any servicing other than those specified in the operating instructions unless qualified to do so.

1. Read all instructions before installing. For electrical work, follow all local and national wiring standards, regulations, and these installation instructions.
2. Make sure the inverter is properly grounded. All wiring should be in accordance with the National Electrical Code (NEC), ANSI/NFPA 70.
3. The inverter and system can inter-connect with the utility grid only if the utility provider permits. Consult with the local AHJ (Authority Having Jurisdiction) before installing this product for any additional regulations and requirements for the immediate area.
4. All warning labels and nameplates on the inverter should be clearly visible and must not be removed or covered.
5. The installer should consider the safety of future users when choosing the inverter's correct position and location as specified in this manual.
6. Keep children from touching or misusing the inverter and relevant systems.
7. **Beware!** The inverter and some parts of the system can be hot when in use. Do not touch the inverter's surface or most of the parts when they are operating. During operation, only the LCD and buttons should be touched.



WARNING!

Cancer and Reproductive Harm – See www.P65Warnings.ca.gov for more details.

DISCLAIMER

EG4 reserves the right to make changes to the material herein at any time without notice.

Please refer to www.eg4electronics.com for the most updated version of our manuals/spec sheets.

3. SÉCURITÉ DE L'ONDULEUR

3.1 INSTRUCTIONS DE SÉCURITÉ

Les réglementations internationales de sécurité ont été strictement observées lors de la conception et des tests de l'onduleur. Avant de commencer tout travail, lisez attentivement toutes les instructions de sécurité et respectez-les toujours lorsque vous travaillez sur ou avec l'onduleur. L'installation doit suivre toutes les normes et réglementations nationales ou locales applicables. Consultez l'autorité locale compétente et/ou le fournisseur d'électricité pour obtenir les permis et autorisations nécessaires avant l'installation.

Une installation incorrecte peut causer:

- Des blessures ou la mort de l'installateur, de l'opérateur ou d'un tiers
- Des dommages à l'onduleur ou à d'autres équipements connectés

3.2 NOTIFICATIONS DE SÉCURITÉ IMPORTANTES



DANGER: *Circuits à haute tension!*

Il y a divers problèmes de sécurité qui doivent être soigneusement observés avant, pendant et après l'installation, ainsi que pendant l'exploitation et la maintenance futures. Les notifications de sécurité suivantes sont importantes pour l'installateur et tout utilisateur final de ce produit dans des conditions normales de fonctionnement.

1. **Attention à la haute tension PV.** Installez un interrupteur ou disjoncteur externe de déconnexion DC et assurez-vous qu'il est en position "off" ou "ouvert" avant d'installer ou de travailler sur l'onduleur. Utilisez un voltmètre pour confirmer qu'il n'y a pas de tension DC présente afin d'éviter les chocs électriques.
2. **Attention à la haute tension du réseau.** Assurez-vous que l'interrupteur AC et/ou le disjoncteur AC sont en position "off" ou "ouvert" avant d'installer ou de travailler sur l'onduleur. Utilisez un voltmètre pour confirmer qu'il n'y a pas de tension présente afin d'éviter les chocs électriques.
3. **Attention au courant élevé de la batterie.** Assurez-vous que les disjoncteurs des modules de batterie et/ou les interrupteurs on/off sont en position "ouvert" ou "off" avant d'installer ou de travailler sur l'onduleur. Utilisez un voltmètre pour confirmer qu'il n'y a pas de tension DC présente afin d'éviter les chocs électriques.
4. **Ne pas ouvrir l'onduleur pendant qu'il fonctionne pour éviter les chocs électriques et les dommages dus à la tension et au courant en direct dans le système.**
5. Ne pas effectuer de connexions ou de déconnexions (PV, batterie, réseau, communication, etc.) pendant que l'onduleur fonctionne.
6. Un installateur doit s'assurer d'être bien protégé par un équipement isolant raisonnable et professionnel (par exemple, équipement de protection individuelle (EPI)).
7. Avant d'installer, d'exploiter ou de maintenir le système, il est important d'inspecter tous les câblages existants pour s'assurer qu'ils répondent aux spécifications et conditions appropriées pour l'utilisation.
8. Assurez-vous que les connexions PV, batterie et réseau à l'onduleur sont sécurisées et appropriées pour éviter les dommages ou les blessures causés par une installation incorrecte.
9. Certains composants du système peuvent être très lourds. Assurez-vous d'utiliser des techniques de levage en équipe parmi d'autres techniques de levage sûres tout au long de l'installation.



AVERTISSEMENT : POUR RÉDUIRE LE RISQUE DE BLESSURE, LISEZ TOUTES LES INSTRUCTIONS !

Tous les travaux sur ce produit (conception du système, installation, exploitation, réglage, configuration et maintenance) doivent être effectués par du personnel qualifié. Pour réduire le risque de choc électrique, ne réalisez aucun entretien autre que ceux spécifiés dans les instructions de fonctionnement, sauf si vous êtes qualifié pour le faire.

10. Lisez toutes les instructions avant d'installer. Pour les travaux électriques, suivez toutes les normes et réglementations locales et nationales de câblage, ainsi que ces instructions d'installation.
11. Assurez-vous que l'onduleur est correctement mis à la terre. Tous les câblages doivent être conformes au Code National de l'Électricité (NEC), ANSI/NFPA 70.
12. L'onduleur et le système peuvent se connecter au réseau électrique uniquement si le fournisseur d'électricité le permet. Consultez l'autorité locale compétente avant d'installer ce produit pour toute réglementation et exigence supplémentaire pour la zone immédiate.
13. Toutes les étiquettes d'avertissement et les plaques signalétiques sur l'onduleur doivent être clairement visibles et ne doivent pas être retirées ou couvertes.
14. L'installateur doit tenir compte de la sécurité des futurs utilisateurs lors du choix de la position et de l'emplacement corrects de l'onduleur, comme spécifié dans ce manuel.
15. Empêchez les enfants de toucher ou de mal utiliser l'onduleur et les systèmes pertinents.
16. **Attention !** L'onduleur et certaines parties du système peuvent être chauds lorsqu'ils sont utilisés. Ne touchez pas la surface de l'onduleur ou la plupart des pièces lorsqu'elles fonctionnent. Pendant le fonctionnement, seuls l'écran LCD et les boutons doivent être touchés.



AVERTISSEMENT !

Cancer et dommages reproductifs – Voir www.P65Warnings.ca.gov pour plus de détails.

DISCLAIMER

EG4® se réserve le droit de modifier le contenu de ce document à tout moment sans préavis. Veuillez consulter www.eg4electronics.com pour la version la plus récente de nos manuels/fiches techniques.

4. CABLE BOX KNOCKOUTS

Back View of the Cable Box Knockouts

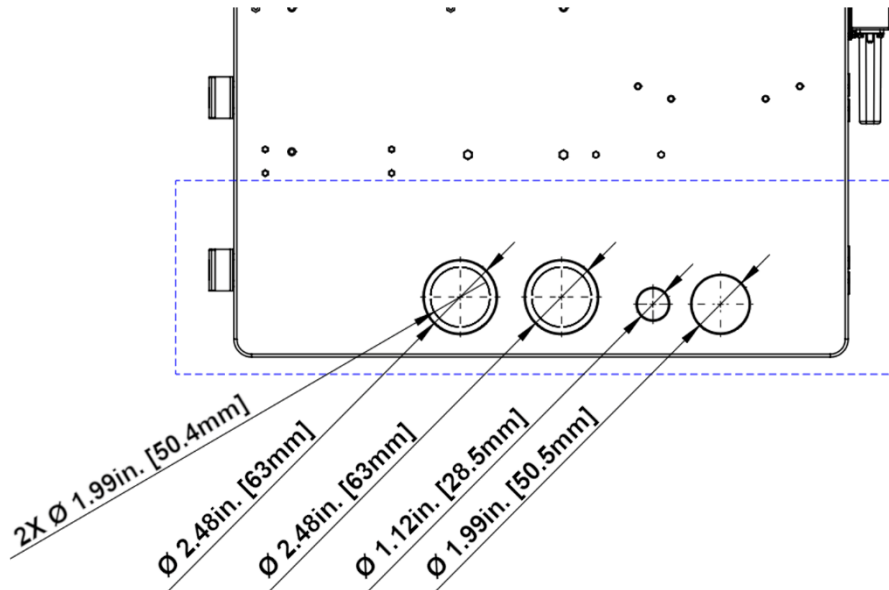

Bottom View of Cable Box Knockouts

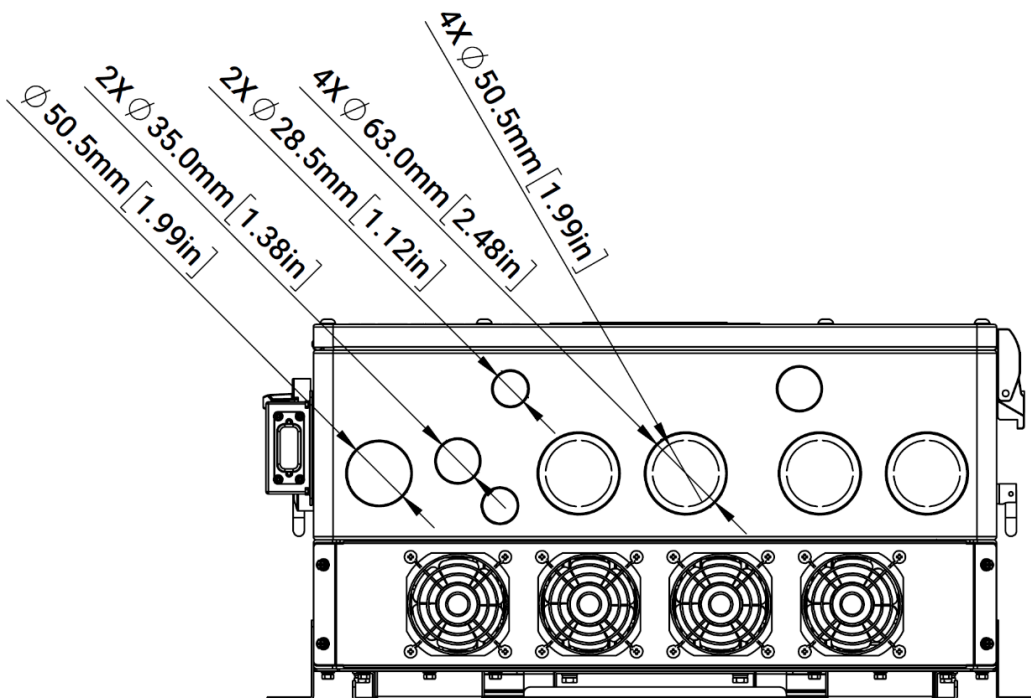

U.S. NOM. TRADE SIZE	ACTUAL KNOCKOUT SIZE
1/2 in.	0.88 in. (22.2 mm)
3/4 in.	1.12 in. (28.5 mm)
1 in.	1.38 in. (35 mm)
1 1/4 in.	1.73 in. (44 mm)
1 1/2 in.	1.99 in. (50.5 mm)
2 in.	2.48 in. (63 mm)

5. PV CONNECTION

5.1 CONNECTING PV TO THE INVERTER



CAUTION:

Consult with an installer to ensure that appropriate cable sizing is used; due to various factors such as voltage drop and VOC.

PV CABLE SIZE	MINIMUM INSULATOR VOLTAGE
10 AWG – 6 AWG (Max) (6 mm ² – 16 mm ²)	600V



REMINDER:

Verify the lowest ambient temperature of the installation location. The rated Voc on the solar module nameplate is obtained at Standard Testing Conditions (STC) (77°F/25°C). As the ambient temperature drops, the solar module VOC increases. Ensure the maximum solar string voltage, corrected at the lowest temperature, DOES NOT EXCEED the inverter's maximum input voltage of 600VDC.

PV INPUT DATA	DESCRIPTION	PARAMETER
DC Input Voltage Range	Range required for the unit to operate up to max input	100 – 600 VDC
Unit Startup Voltage	Voltage needed for the LCD to power on	100 VDC
Load Output Minimum Voltage	Minimum voltage needed to output power on Load side	>140 VDC
MPP Operating Voltage Range	Range where the MPPT can track	120 – 500 VDC
Nominal MPPT Voltage	The MPPT will operate most optimally at this voltage	360 VDC
Maximum Utilized Solar Power	Watts the unit can utilize from array after considering all power loss factors	12kW
Rec. Maximum Solar Input	The suggested PV power input into the device for it to utilize the full 8kW of PV	15kW

String Sizing

When solar modules are wired in series, the voltage is multiplied by the number of modules and the amperage stays the same as the rating of each module.

For example: Using solar modules that have a 40VDC VOC (@77°F) with a max. power current of 10 Amps (I_{mp}) – 10 modules wired in a series string would have a VOC of 400 VDC (@77°F) and a string amperage of 10 Amps. When the temperature lowers, the voltage can rise above the maximum allowed by the MPPT and damage will result.

Finally, calculate the maximum current of the string so as not to exceed the inverter's MPPT circuit ratings. Double check if the calculated V_{mp} range is within the 120-500 VDC optimal MPPT circuit operating range. It is recommended to consult a solar designer for assistance.

FOR ALL MODULES, THE CALCULATIONS NEED TO BE PERFORMED OR VERIFIED BY USING A STRING CALCULATOR AND CONSULTING A PROFESSIONAL.



CAUTION:

To determine how many modules are ideal per string, first verify the lowest possible ambient temperature of the installation location. Next, find the rated VOC, VMP, Isc and Imp of the solar module at 25°C and the temperature coefficients for voltage and power. Then calculate highest possible VOC for the entire string when the ambient temperature falls to the lowest possible ambient temperature upon sunrise. To make this calculation, use a string calculator or consult a solar designer or solar technician.

The inverter has two separate MPPTs which will utilize up to 25A each. Therefore, two strings can be paralleled for any modules having less than 12.5A (Imp) rating.

When sizing strings for each MPPT, they **MUST** be the same model, brand and number per string (series and parallel).

All panels in a series/parallel string should face the same orientation and be exposed to roughly the same shading across the string. Consideration should be placed on string location and wiring order on the racking to minimize shading effects. One shaded module can disproportionately reduce output for the entire string. This is because shading on a solar module will cause a drop in voltage. All panels in a string will drop to match the lowest voltage experienced in any module. Using Optimizers and/or avoiding linear strings in favor of rectangular strings can minimize losses due to shading.



NOTE:

The array may have a higher Imp than the 25A specified, but the MPPTs will not make full use of the extra current and may lead to component deterioration over time.

5.2 PV WIRING INSTRUCTIONS

Follow the steps listed below to ensure proper PV connections:

1. It is recommended to install a separate PV Isolator disconnect near the inverter for ease of installation and added safety. Before installing PV wiring into the inverter, ensure all breakers and disconnects are open (off) and confirm the PV strings are not energized by using a multimeter to ensure there is no DC voltage on the lines. Once that has been verified, proceed to step 2.
2. Strip off 1/2 – 2/3 in. (12.7 – 17 mm) insulation from the PV strings' positive and negative conductors.
3. Insert the conduit fitting into the opening for the PV connection and tighten it from the inside using the counter nut.
4. Route the PV conductors through the conduit fitting and into the inverter.
5. Secure the PV conductors in place to the inverter inputs. Verify that they are secured properly by lightly pulling on them.
6. Ensure the conduit and conduit fittings are fastened reliably and the cable entry holes are sealed.



NOTE:

If using fine stranded wire, use ferrules to secure the connection.

DO NOT GROUND NEGATIVE PV LINES, ONLY SOLAR PANEL FRAMES.



NOTE:

It is recommended to install a separate DC earth ground for grounding of the solar panel frames. This ground should connect to the existing DC earth ground rod. All exposed metal parts of the system must be grounded regardless of voltage.

See the diagram below for PV terminal labeling.

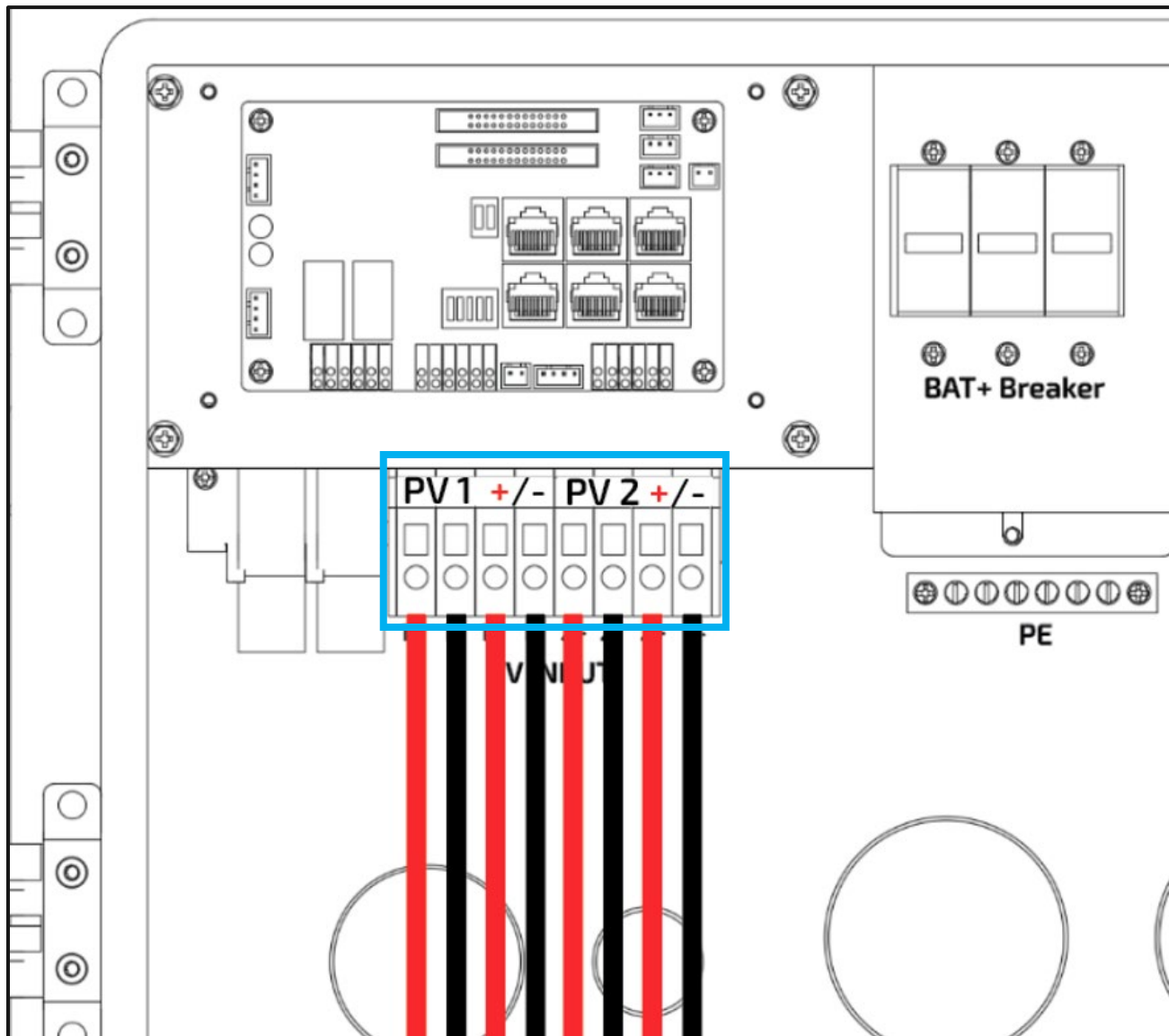

6. BATTERY CONNECTION

The EG4® 12kPV can utilize either lithium or lead-acid batteries. For each battery type, there is a specific combination of settings (*See the battery user manual for more information*).

6.1 BATTERY CABLE CONNECTION

Follow the steps below to properly connect the battery cables:

1. Place all breakers in the open (off) position before connecting or disconnecting wires. Ensure there is no voltage present by using a voltmeter.
2. If using a battery rack, ensure all battery connections are installed properly before proceeding. Refer to the battery rack manual for more information.



NOTE:

Size all battery cables accordingly! Refer to an NEC approved ampacity chart or consult with the installer or solar electrician for more information.

3. Connect the positive battery cable (RED) to the positive battery terminal (BAT+) and the negative battery cable (Black) to the negative battery terminal (BAT-) with a torque rating of 150 in-lbs. (17Nm) per connection.
4. Be sure not to cross polarize, as this will damage the equipment.



NOTE:

The recommended battery capacity of one 12kPV inverter is ≥200AH.

The recommended battery cable and terminal size are as follows:

MAX. CONTINUOUS CHARGE/DISCHARGE AMPERAGE	BATTERY CAPACITY	WIRE SIZE	TORQUE VALUE
167A	200AH	2/0 AWG	150 in-lbs. (17Nm)

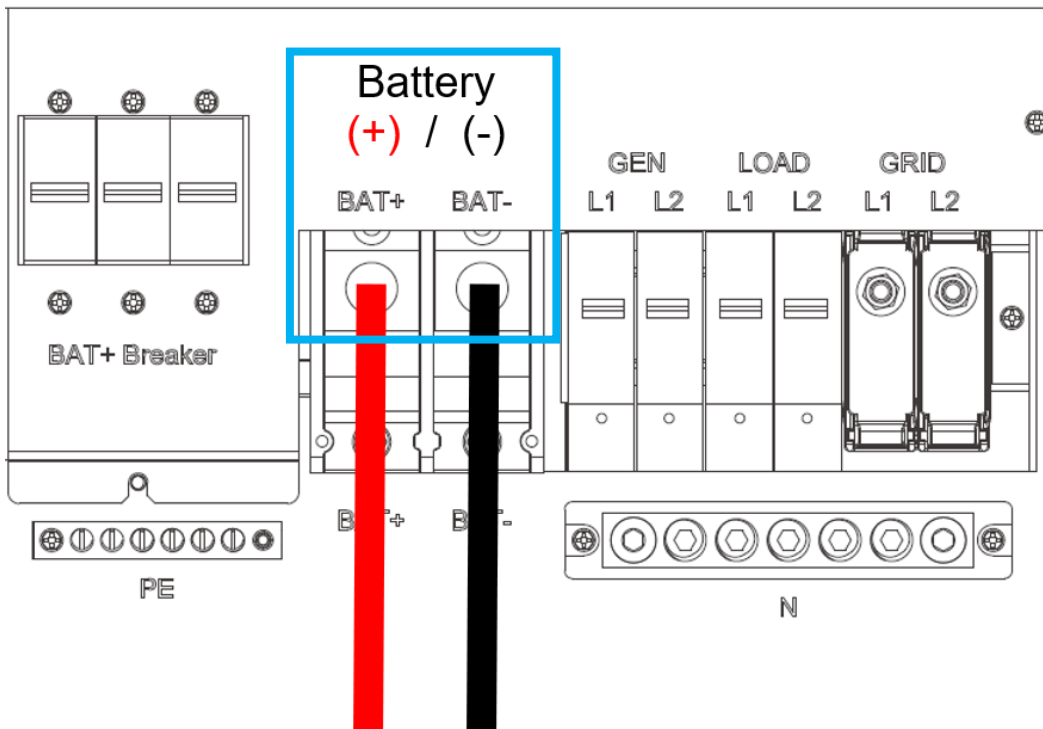

6.2 LITHIUM BATTERY COMMUNICATIONS

Upon successful installation of the batteries, follow the next steps to enable closed-loop communications (with compatible battery modules) between batteries and inverter.

1. Connect either the CAN or RS485 (depending on make/model of battery) communications cable between inverter and master battery. *See diagram below.*
2. For the inverter to communicate with the battery BMS, setting 3 must be changed to “Li-ion”.
3. The inverter will then switch to a secondary setting. Here, select the appropriate model of battery and press enter.

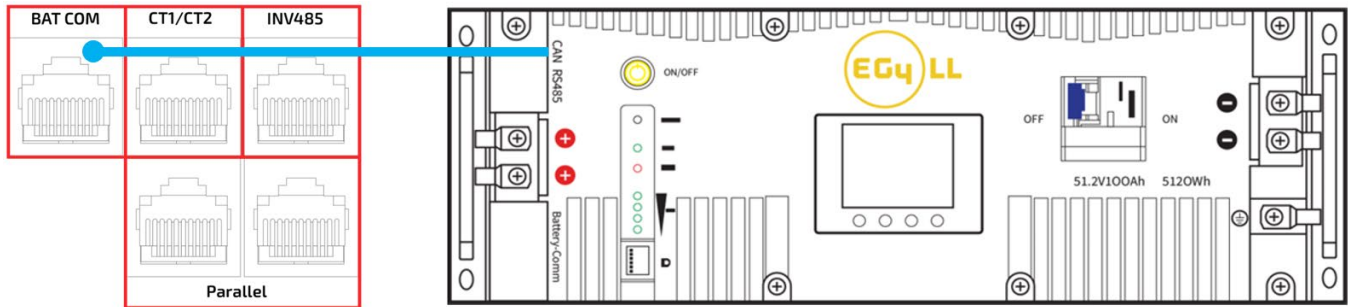

The table below shows the communication protocol for the inverter. For battery specific pinouts, refer to the battery user manual.

PIN #		1	2	3	4	5	6	7	8
CAN	Pin	X	X	X	BMS_CAN H	BMS_CAN L	X	X	X
RS485	Description	BMS_485 B	BMS_485 A	X	X	X			

7. AC CONNECTION

When sizing AC wires, adhere to the following information.

AC Cable Requirements:

TERMINAL CONNECTION	WIRE SIZE	TORQUE VALUES
GRID	Max. 4 AWG (21.2 mm ²)	17.7 in. lbs. (2Nm)
GEN	Max. 4 AWG (21.2 mm ²)	17.7 in. lbs. (2Nm)
LOAD	Max. 4 AWG (21.2 mm ²)	17.7 in. lbs. (2Nm)

Neutral-Ground Bonding

The information below describes the nature of the neutral and ground in the inverter and their relationship to the system. Always consult with an installer or a licensed electrician to ensure that the right configuration is being used:

- The neutral line is a solid connection between AC input and AC output (known as a Common Neutral Architecture).
- The neutral line between the AC input and AC output is never disconnected.
- This architecture assumes there is a single neutral-ground bond in the system. Typically, the neutral-ground bond for a system will be located at the first means of disconnect for the grid.



REMINDER:

The system should have one and only one neutral-ground bond. (This is typically the Main Bonding Jumper located at the first grid system disconnect.)

7.1 STEPS FOR AC CONNECTION

Follow the steps outlined below to ensure proper AC Input/Output connections:

1. Before installation of **any** wiring, ensure all breakers are open (off) before making any connections. Use a multimeter to confirm the AC Input lines (L1, L2 and neutral) are not energized.
2. Strip off 3/5 – 4/5 in. (15.2 – 20.3 mm) insulation from the AC cables.



NOTE:

If using fine stranded wire, use ferrules to secure the connection.

3. Insert the conduit fitting into the opening for the AC connection and tighten it from the inside using the counter nut.
4. Route the AC conductors through the conduit fitting and into the inverter.
5. Fasten the AC Input wires into their respective terminals using the proper torque (17.7 in. lbs. – 2 Nm). The terminals located above “N.BUS” (neutral bus) are defined as such: LOAD is the AC output, GRID (input) is the AC terminal, and GEN is the generator’s input.
6. Ensure the conduit and conduit fittings are fastened reliably and the cable entry holes are sealed.



NOTE:

Always be sure to connect the AC Output ground wire to the Ground terminal first before installing the AC Outputs L1 and L2.

See the diagram below for terminal labeling.

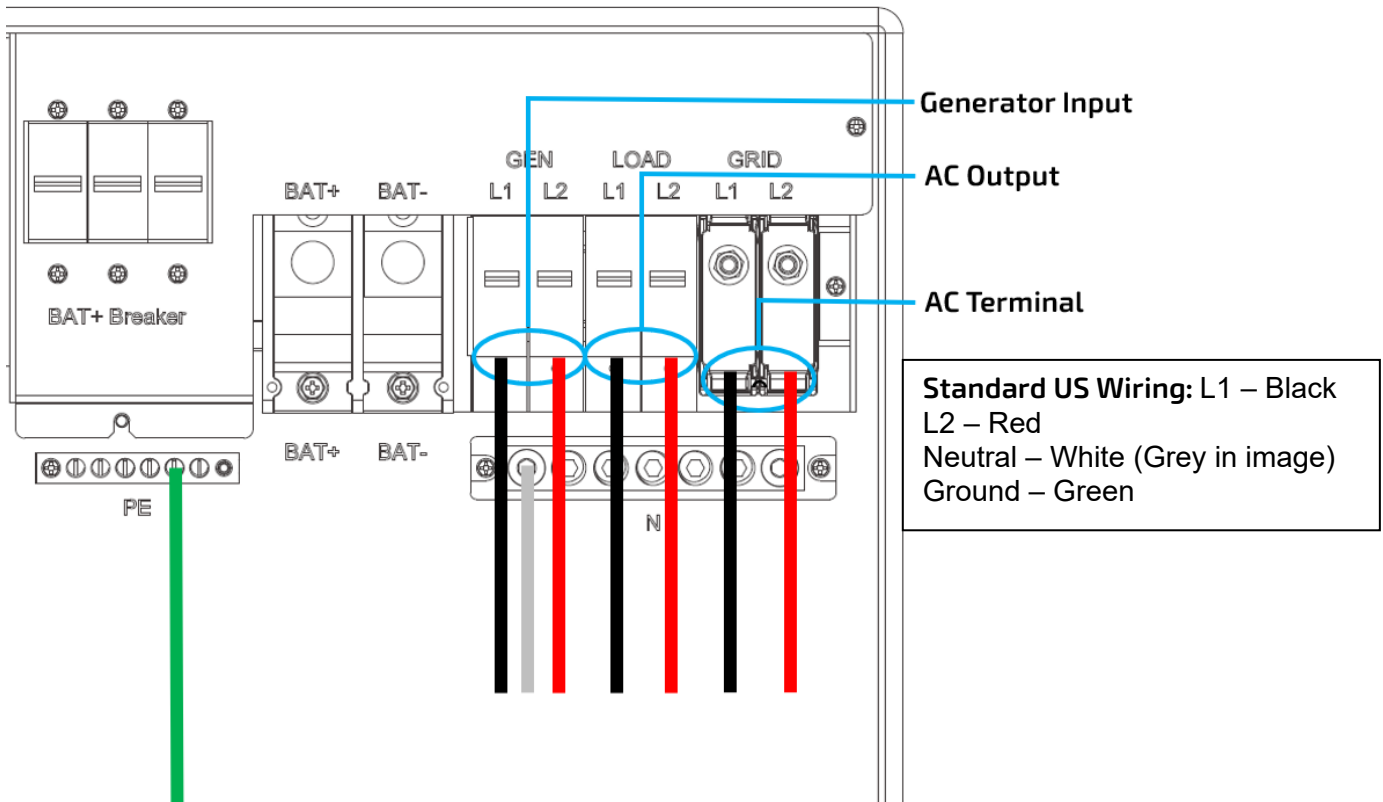

7.2 CURRENT TRANSFORMER (CT) CONNECTION

To measure the power imported from and exported to the grid, a pair of CTs or one three-phase meter must be installed at the service entry point in or near the main service panel. Two CTs are provided with each inverter.

CT Port Pin Definition

The interface for the CT connections is one RJ45 port labeled: CT1/CT2. The included CTs come with prewired connectors so they can be connected directly to their respective ports.

PIN(S)	DESCRIPTION
1-4	Reserved
5	CT2N CT2P
6	CT2P
7	CT1N
8	CT1P

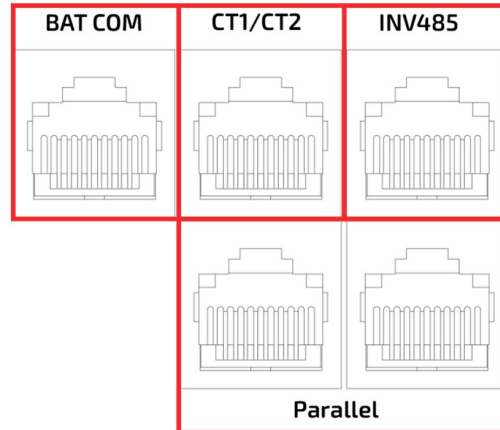

If a cable for CT connections is needed, the diagram on the right and the table above show which pins are utilized for proper operations.

The following diagram shows the connections and installation orientation of the CTs. For the CTs to function as intended, they must be installed as shown in the diagram to the right. Begin by clamping CT1 (labeled) on the AC Input Line 1 (L1). Clamp CT2 (labeled) on AC Input Line 2 (L2), and make sure the arrows on the CTs are pointing towards the inverter.

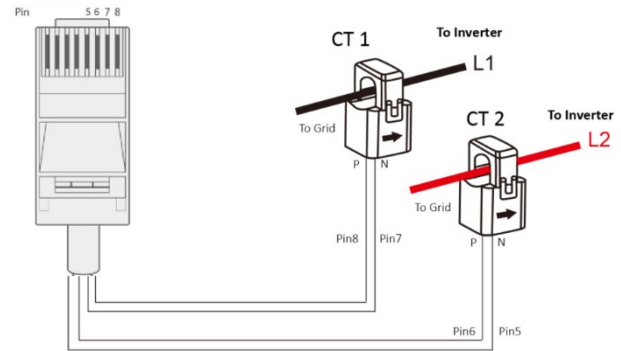

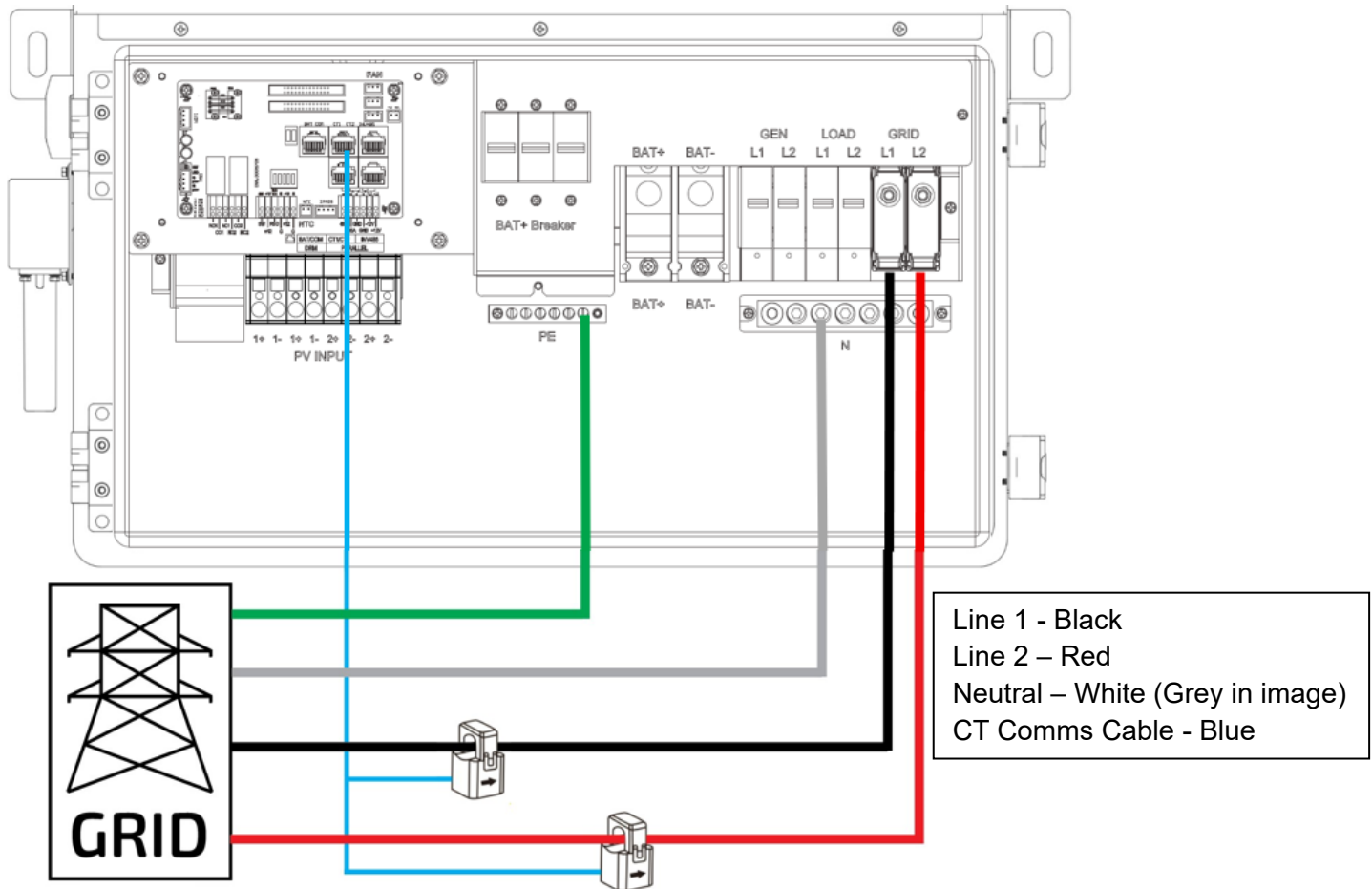

Once the CTs are clamped on the AC Input Lines, connect the CT communications cable (RJ45) to the port on the inverter.



NOTE:

The CTs must be installed in or near the Main Service Panel for accurate readings.

CT Clamp Ratio

The 12kPV supports 3 ratios of CT clamps – 1000:1, 2000:1 and 3000:1. The CT clamps included with the inverter are rated at 3000:1. If using a 3rd party CT, ensure that the CTs match one of the above ratios. Next, navigate to the inverter settings (either on the physical display or via the monitoring page) and select the correct CT ratio according to the hardware.



Extending the CT Clamp Cable
 The CT communications cable can be extended with a common ethernet cable if more length is required. An RJ45 jack-to-jack adapter is required to extend the existing cable. The CT communications cable can be extended up to 300 ft. (around 100 m).

7.3 OFF-GRID CONNECTION

The 12kPV can function fully in off-grid only mode, eliminating the need for utility or a generator. It is highly recommended that purely off-grid systems without access to the utility have a backup generator with remote start for extended cloudy periods (minimum 5kW diesel generator per 12kPV inverter). Off-grid systems should have robust battery banks sized to ensure multiple days of power and to reduce generator run time.

The 12kPV can also utilize AC-coupled solar input through the GEN port in purely off-grid systems. The generator can then be connected to the grid port in case of emergency. The inverter must be set to Microgrid anytime a generator is connected to the grid port.

Off-Grid Wiring

The 12kPV can accept up to 50 Amps (12kW) of generator power and will pass all available power through to the loads. The main breaker in the Loads subpanel can be selected based on the number of inverters, with a 60A minimum per inverter.

8. GENERATOR CONNECTION

8.1 GENERATOR SYSTEM CONNECTION

The 12kPV can utilize supplemental 240VAC generator power ($\geq 12\text{kW}$ generator recommended) for backup in the case of grid failure. When sizing generators to provide adequate power and optimal frequency, the Total Harmonic Distortion (THD) of the generator must be $< 3\%$. To achieve this optimal THD value, it is recommended to size the generator for **at least** 1.5x the output of the inverter to allow for powering loads and charging batteries. The table below shows the recommended generator capacity for optimal operations.

NUMBER OF INVERTERS IN PARALLEL	RECOMMENDED GENERATOR CAPACITY
1	>12kW
2	>24kW
3	>36kW
4	>48kW

When properly wired and configured, the generator will start automatically when the battery voltage is lower than the cut-off value or there is a charge request from the BMS. When the generator is running, it will charge the batteries and excess AC power will be diverted to the AC output (LOAD) to power loads. The pass-through relay on the inverter’s Generator terminal (GEN) is 50A. When the generator is on, ensure the total load and charge current does not exceed 50A. When utilizing the “Gen Boost” function and the generator’s power is not adequate to power all loads, the inverter will pull from batteries and PV as supplemental power. When the battery voltage exceeds the threshold for AC charging, the generator will stop.

8.2 DRY CONTACT INFORMATION (GEN PORT)

This inverter has a dry contact connection that can be used to remotely enable external devices such as a generator. The GEN contacts (NO1, CO1) can be used to remotely start a generator. To do so, the generator start signal must be connected to the inverter GEN contacts, NO1 and CO1.

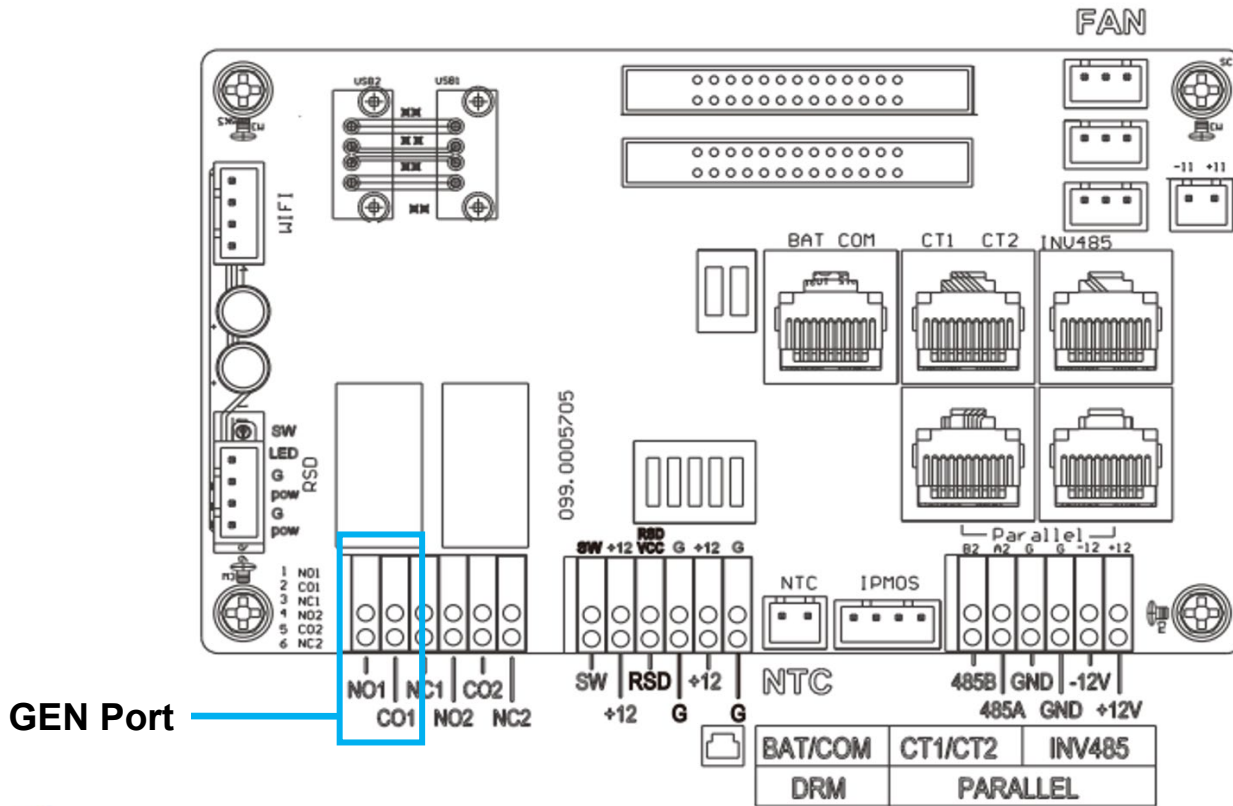

NOTE:

NO1 = Normally Open, CO1 = Common. GEN contact relay maximum specification: 250VAC, 5A

8.3 GENERATOR AC CONNECTIONS



NOTE:

If running more than one inverter in the system, the generator must be wired to provide power to EVERY inverter running in parallel for the inverters to function as intended.

Follow the steps listed below to ensure the generator connections are installed correctly:

1. Before making any wiring connections, be sure to have the inverter(s) powered off, the generator powered off, and all circuit breakers open (off) to prevent damage to the unit.
2. Properly identify the generator's output lines. By US wiring standards, the L1 wire will be black and the L2 will be red, neutral will be white, and ground will be green or bare. Once identified, remove approximately 3/8in. (10mm) from the insulation sleeve on the wires.
3. Ground the generator's output ground to the ground bus (labelled PE) of the inverter.
4. Install L1 (black) to the GEN port's L1 terminal, then install L2 (red) to the GEN port's L2 terminal. Next, fasten the neutral (white) wire (represented by grey wire in image) from the generator into the N-BUS GEN port terminal.

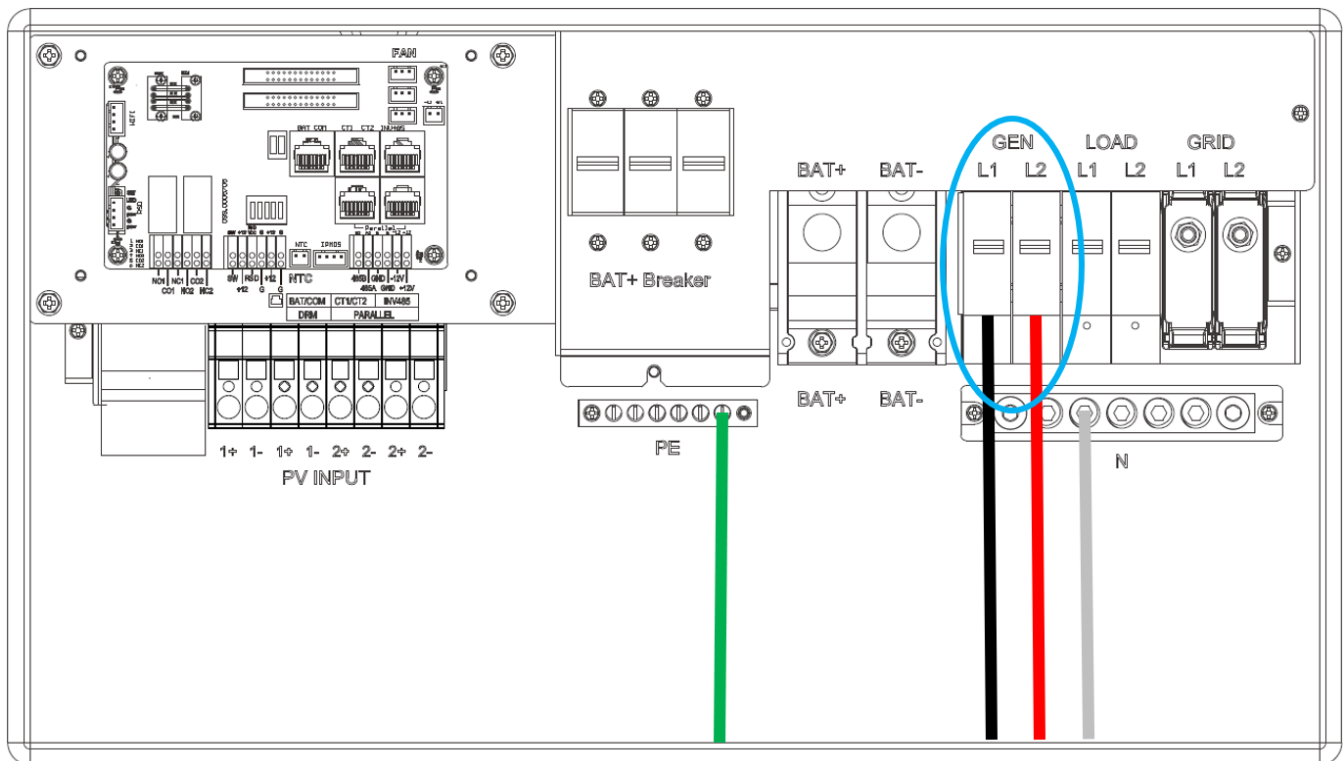

8.4 GENERATOR START AND STOP SETTINGS

Using the EG4® Monitoring Center, go to the “Maintenance” page, where “Remote Set” will be selected automatically. In the “Model” section in “Common Setting”, select the “Battery Type” (see *image below*). Normally, lead-acid batteries are charged according to voltage and lithium batteries are charged according to SOC. Scroll down to the “Generator Charge” section to find the “Charge Start Volt(V)/SOC(%)” and “Charge End Volt(V)/SOC(%)” settings.



WARNING:

The system must be placed into standby mode via the Monitor Center or LCD screen before changing the battery type setting.

The image displays two screenshots of the EG4 Monitoring Center interface. The top screenshot shows the 'Common Setting' page. The 'Battery Type' dropdown menu is open, showing options: '<Empty>', '0: No battery', '1: Lead-acid', and '2: Lithium'. The bottom screenshot shows the 'Generator Charge' page. The 'Charge Start Volt(V)' is set to 40, 'Charge End Volt(V)' is set to 56, 'Charge Start SOC(%)' is set to 10, and 'Charge End SOC(%)' is set to 100. These four settings are highlighted with blue boxes.

Generator Start Conditions:

The generator will start *when utility fails and* one of the following conditions are met:

- The battery is discharged to the cut-off setting **or**
- There is a force charge request from battery **or**
- The battery voltage or SOC is lower than the “**Charge Start Volt(V)/SOC(%)**” setting.

Generator Stop Conditions:

When battery voltage or SOC is higher than the “**Charge End Volt(V)/SOC(%)**” settings.

9. PARALLELING INFORMATION

9.1 PARALLEL COMMUNICATION CONNECTIONS

Multiple 12kPVs can be paralleled to expand energy storage and backup capacity to suit different scenarios. **Up to 10 units can be paralleled to reach a load capacity of up to 80kW.** The parallel communication wiring diagrams are shown below.



REMINDER:

Put the CAN communication PIN to ON status for the first and last inverter and OFF for inverters in between.

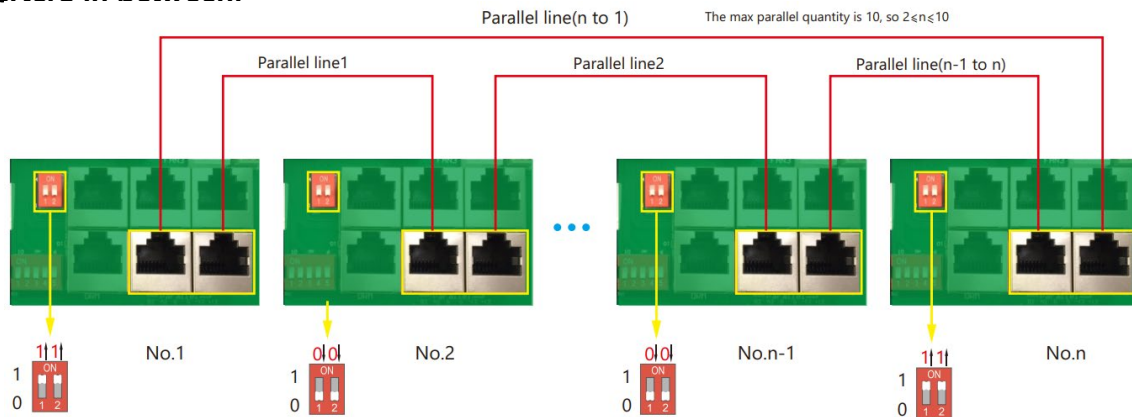

NOTE:

Both switches in the “ON” position translates to address 1. Both switches in the “OFF” position translates to address 0.

Contact the inverter supplier for more detailed guidance on paralleling systems.

9.2 PARALLEL CONFIGURATION

Important notices for parallel system:

- If utilizing the Generator input (GEN), ensure that the generator is connected to all inverters in parallel.
- If it is not possible to evenly divide solar strings per inverter, it is recommended to have more PV strings on the master inverter.
- The values shown on the LCD of each inverter display the individual inverter’s contribution to the system, **not the system’s total.**



REMINDER:

If needing to extend the inverter-to-inverter paralleling cable, ensure the cable is a straight-through CAT5 and up cable. See image below for reference.

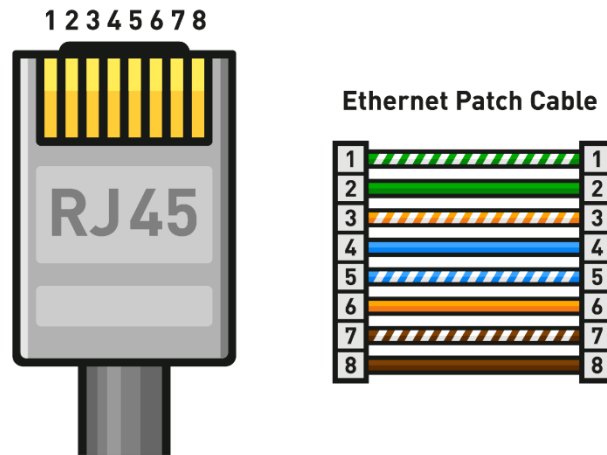

Before commissioning:

1. Verify that all inverters in the system are updated to the latest firmware. Contact the distributor to confirm the latest version.
2. Make sure the power cables and parallel communications cables have been properly connected and verify the DIP-switch settings are correct.
3. If using battery power, close (turn on) the battery breaker and then begin powering batteries on one by one to provide power to the inverter, If using AC power, close the GRID breaker to power on the inverter.
4. Set the system to standby via the “**Basic**” page in the settings.
5. Verify that the inverter status is set to “**0.**”
6. Select which unit will be the Master by selecting “**1 phase master**” in Advanced Settings. Set all others to “**Slave.**”
7. Ensure all inverters are set to “**R**” phase.
8. For closed-loop communications, enable “**Share Battery**” setting for all paralleled inverters.
9. Ensure the battery to inverter communications cable is properly connected from master battery to the master inverter.

Commissioning steps:

1. Turn on the battery and make sure the communication works on all units.
2. Check the parallel info via the Home page.
3. Turn on the “**Off-grid output**” function in the “**Advanced**” page.
4. Before connecting load to load output terminal, check the output of L1 to N (120V in the U.S.), L2 to N (120V in the U.S.) and L1 to L2 (240V in the U.S.).
5. Add some small loads to the load output and verify power output.

10. WARRANTY INFORMATION

For information regarding warranty registration on EG4® Electronics products, please navigate to <https://eg4electronics.com/warranty/> and select the corresponding product to begin the registration process.

CHANGELOG

Version 1.2.6

- Modified AC input power max from 12000 to 8000W
- Added French safety section & warnings

Version 1.2.3

- Added cable box knockout dimensions image.

Version 1.2.2

- Modified warranty information

Version 1.2.1

- Added California Prop. 65 warning label to Safety section

Version 1.2

- Added warranty information
- Updated safety information

Version 1.1

- Modified safety information for consistency.
- Changed verbiage throughout document for clarity.
- Modified Max. Usable Input Current & Max. Short Circuit Input Current for clarity in Sec. 1.
- Added additional grounding information to Sec. 3.2.
- Modified Battery Cable Connection list and table for clarity in Sec. 4.1.
- Modified Sec. 5.1 for consistency and clarity.
- Added additional setting information in Sec. 6.4.
- Modified Sec. 7.2 list for clarity.
- Modified structure of document for readability.

Version 1.0.1

- Added inverter communication pinout to Section 7.2

Version 1.0

- First version completed.



CONTACT US

support@eg4electronics.com

(903) 609-1988

www.eg4electronics.com