

EG4[®] WALLMOUNT ALL WEATHER 280Ah LITHIUM BATTERY

QUICK-START GUIDE



TABLE OF CONTENTS

1.	SAFETY.....	1
1.1	SAFETY INSTRUCTIONS.....	1
1.2	IMPORTANT SAFETY NOTIFICATIONS.....	1
2.	PACKING LIST.....	3
2.1	LOCATION SELECTION AND INSTALLATION	3
3.	PARALLEL EXAMPLES.....	3
4.	ORIENTATION EXAMPLES.....	4
5.	INSTALLING THE BATTERY.....	5
5.1	STANDALONE BATTERY INSTALL	5
5.2	BATTERY INSTALL WITH CONDUIT BOX.....	6
5.3	BATTERY INSTALL WITH CONDUIT BOX & 18KPV	6
6.	PRE-WIRE STEPS AND WIRING	8
6.1	MULTIPLE BATTERY PARALLEL INSTALL.....	8
6.2	MULTIMETER TESTING AND WIRING.....	9
7.	BMS COMMUNICATIONS.....	9
7.1	CLOSED LOOP COMMUNICATIONS	10
8.	FIRMWARE UPDATES	11
9.	WARRANTY INFORMATION.....	11
10.	CHANGELOG.....	12

1. SAFETY

1.1 SAFETY INSTRUCTIONS



DANGER!

AVERTISSEMENT!

Hazardous Voltage Circuits!

Circuits à tension élevée!

International safety regulations have been strictly observed in the design and testing of the battery. Before beginning any work, carefully read all safety instructions, and always observe them when working on or with the battery. The installation must follow all applicable national or local standards and regulations.

Incorrect installation may cause:

- Injury or death to the installer, operator or third party
- Damage to the battery or other attached equipment

1.2 IMPORTANT SAFETY NOTIFICATIONS

There are various safety concerns that must be carefully observed before, during, and after the installation, as well as during future operation and maintenance. The following are important safety notifications for the installer and any end users of this product under normal operating conditions.

1. **Beware of high PV voltage.** Please install an external DC disconnect switch or breaker and ensure it is in the “off” or “open” position before installing or working on the battery. Use a voltmeter to confirm there is no DC voltage present to avoid electric shock.
2. **Beware of high grid voltage.** Please ensure the AC switch and/or AC breaker are in the “off” or “open” position before installing or working on the battery. Use a voltmeter to confirm there is no voltage present to avoid electric shock.
3. **Beware of high battery current.** Please ensure that the battery module breakers and/or on/off switches are in the “open” or “off” position before installing or working on the battery. Use a voltmeter to confirm there is no DC voltage present to avoid electric shock.
4. **Do not open the battery while it is operating** to avoid electric shock and damage from live voltage and current within the system.
5. **Do not make any connections or disconnections (PV, battery, grid, communication, etc.) while the battery is operating.**
6. An installer should make sure to be well protected by reasonable and professional insulative equipment [e.g., personal protective equipment (PPE)].
7. Before installing, operating, or maintaining the system, it is important to inspect all existing wiring to ensure that it meets the appropriate specifications and conditions for use.
8. Ensure that the PV, battery, and grid connections to the battery are secure and proper to prevent damage or injuries caused by improper installation.



WARNING: To reduce the risk of injury, read all instructions

All work on this product (system design, installation, operation, setting, configuration, and maintenance) must be carried out by qualified personnel. To reduce the risk of electric shock, do not perform any servicing other than those specified in the operating instructions unless you are qualified to do so.

1. Read all instructions before installing. For electrical work, follow all local and national wiring standards, regulations, and these installation instructions.
2. Make sure the battery is properly grounded. All wiring should be in accordance with the National Electrical Code (NEC), ANSI/NFPA 70.
3. The battery and system can inter-connect with the utility grid only if the utility provider permits. Consult with the local AHJ (Authority Having Jurisdiction) before installing this product for any additional regulations and requirements for your area.
4. All warning labels and nameplates on this battery should be clearly visible and must not be removed or covered.
5. The installer should consider the safety of future users when choosing the battery's correct position and location as specified in this manual.
6. Please keep children away from touching or misusing the battery and relevant systems.

DISCLAIMER

EG4 reserves the right to make changes to the material herein at any time without notice.

Please refer to www.eg4electronics.com for the most updated version of our manuals/spec sheets.

2. PACKING LIST

The items listed below will arrive with the product shipment:

EG4 WallMount All Weather

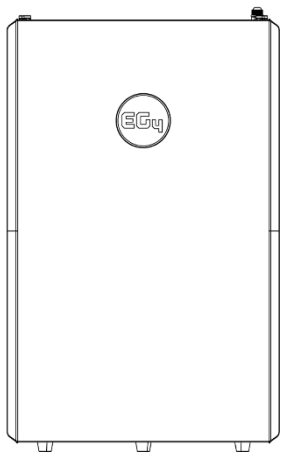

(1) EG4 WallMount All Weather

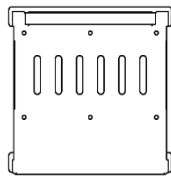

(1) Mounting Bracket *

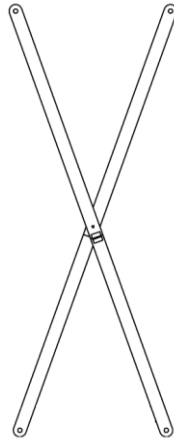

(1) X-Bracket



(6) Concrete Expansion Bolts

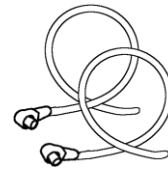

(2) Red power cables 2/0 AWG (39.4 in.)

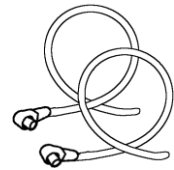

(2) Black power cables 2/0 AWG (39.4 in.)

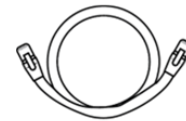

(1) Battery to Inverter Communication Cable

***The mounting bracket will arrive attached to the back of the battery**

2.1 LOCATION SELECTION AND INSTALLATION

Requirements for installation location:

- The WallMount is heavy. Use a lift or other equipment to lift and carry the unit.
- The battery can be installed on either flat ground or on the wall. If installing on flat ground, ensure there is proper drainage on the ground surrounding the battery to maintain integrity of the module over time. If installing on the wall, ensure at least a 6 in. (152.4 mm) gap on each side of the unit for adequate airflow and operations.
- Install the battery in a location that prevents damage from flooding.
- Ensure the battery is mounted upright.
- The battery must be installed with at least 6 in. (152.4 mm) of clearance on all sides of the unit.



NOTE: The battery will be shipped with temporary lifting handles for removing the battery from its packaging. The battery is very heavy. Use the team-lift technique during installation and remove the temporary lifting handles before making any connections within the system.

3. PARALLEL EXAMPLES

The diagrams below show different parallel orientations. These diagrams are for reference only!

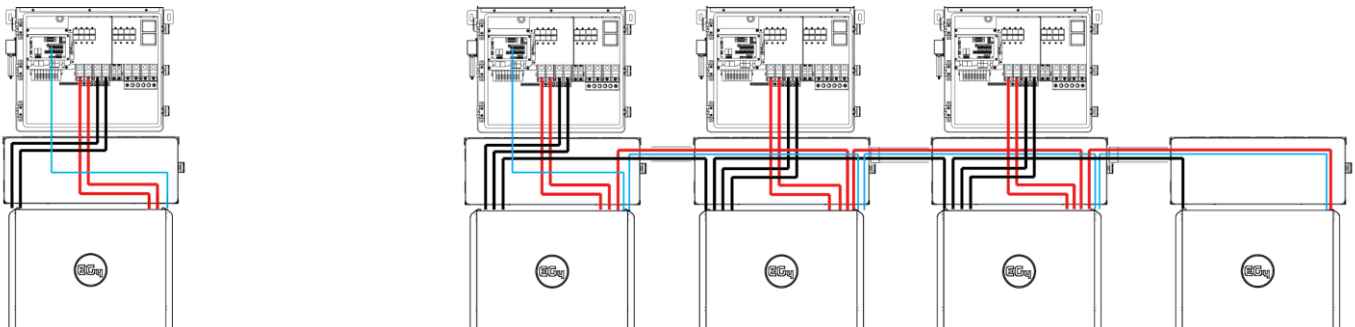

4. ORIENTATION EXAMPLES

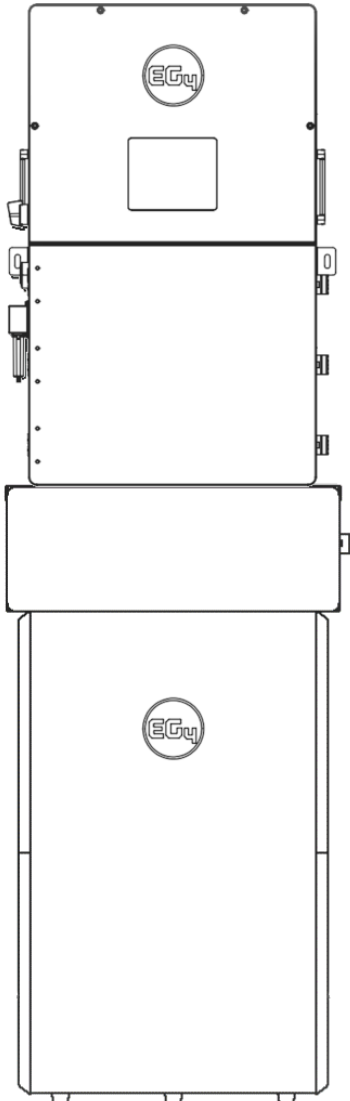

**(1) 18kPV Inverter +
(1) WallMount All
Weather Battery**

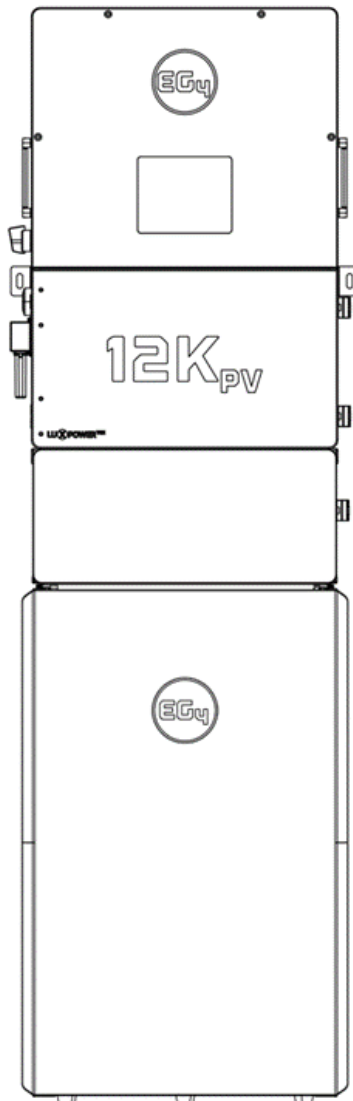

**(1) 12kPV Inverter +
(1) WallMount All
Weather Battery**

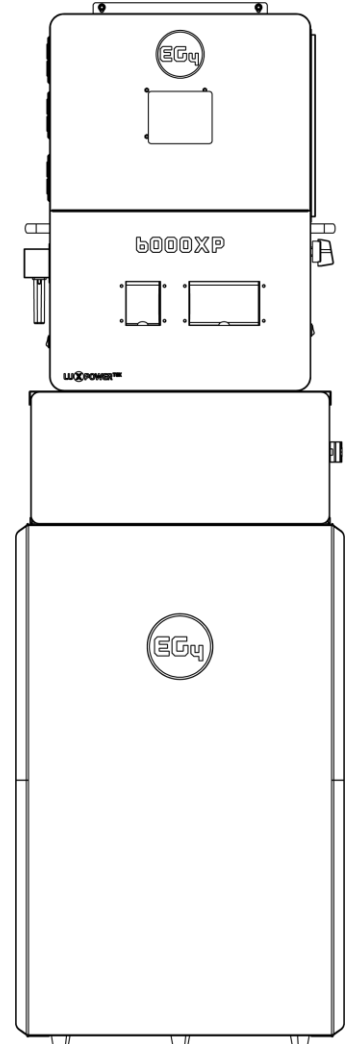

**(1) 6000XP Inverter +
(1) WallMount All
Weather Battery**

5. INSTALLING THE BATTERY

The WallPower All Weather battery is designed to be wall mounted. Follow the steps listed below to ensure the battery is mounted correctly.



NOTE: The battery will be shipped with temporary lifting handles for removing the battery from its packaging. EG4 recommends these handles be removed before making any connections.



NOTE: When installing multiple batteries or adding a battery to an existing rack, please ensure all batteries are charged to 100% before paralleling together. This step is crucial to optimize battery performance and ensure proper operation.

5.1 STANDALONE BATTERY INSTALL

1. Remove the 4 set screws holding the mounting bracket to the back of the battery pack and set them to the side.
2. Remove the mounting bracket from the battery.
3. Position the bottom of the mounting bracket on the wall at desired mounting height, with a minimum clearance of 28.0625 in. from the ground.
4. Using a level, ensure the bracket is level and drill 6 holes to accommodate the mounting hardware used.
5. Secure the mounting bracket to the wall using the included expansion bolts or appropriate hardware required for the mounting surface.
6. Attach the battery pack to the mounting bracket. Using the team-lift technique, lift the battery and hook the back flange onto the front flange of the mounting bracket.
7. Secure the battery to the mounting bracket using the 4 included side screws.
8. Finally, properly ground the battery, attaching a grounding conductor to the M6 grounding screw on top of the battery to the Equipment Grounding System.

DO NOT GROUND THE NEGATIVE BATTERY CABLE!

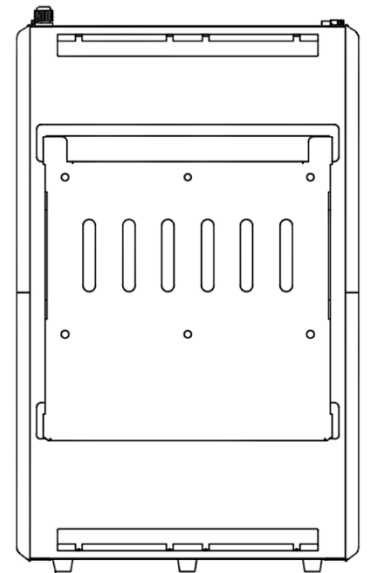

Rear View

5.2 BATTERY INSTALL WITH CONDUIT BOX

1. Remove the 4 set screws holding the mounting bracket to the back of the battery pack and set them to the side.
2. Remove the mounting bracket from the battery.
3. Position the mounting bracket on the wall at desired mounting height, with a minimum clearance of 28.0625 in.
4. Using a level, ensure the bracket is level and drill 6 holes to accommodate the mounting hardware used.
5. Secure the mounting bracket to the wall using the included expansion bolts (concrete or brick walls) or appropriate hardware for the mounting surface.
6. Attach the battery to the mounting bracket. Using the team-lift technique, lift the battery and hook its back flange onto the front flange of the mounting bracket.
7. Secure the battery to the mounting bracket using the 4 included side screws.
8. Attach the optional conduit box to the top of the battery using the included hardware.
9. Finally, properly ground the battery, attaching a grounding conductor to the M6 grounding screw on top of the battery to the Equipment Grounding System.

DO NOT GROUND THE NEGATIVE BATTERY CABLE!

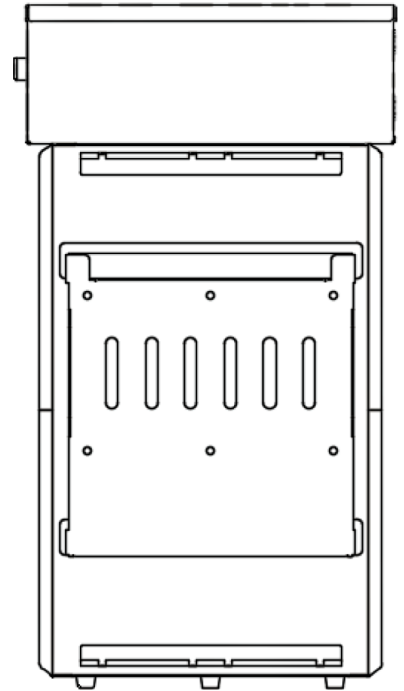

Rear View



NOTE: *If mounting the bracket at 28.0625 in. from the ground, the battery will rest on the ground.*

5.3 BATTERY INSTALL WITH CONDUIT BOX & 18KPV

The WallPower All Weather battery is designed to mate perfectly with the EG4 18kPV Hybrid Inverter. Follow the steps listed below to ensure proper connections are made in the system.

1. Remove the 4 set screws holding the mounting bracket to the back of the battery pack and set them to the side.
2. Remove the mounting bracket from the battery.
3. Position the mounting bracket on the wall at desired mounting height, with a minimum clearance of 28.0625 in.
4. Using a level, ensure the bracket is level and drill 6 holes to accommodate the mounting hardware used.
5. Align the provided X-bracket with the holes on the mounting bracket and secure both to the wall, using the included expansion bolts (concrete/brick walls) or appropriate hardware required for the mounting surface. The X-bracket will be behind the mounting plate, against the wall.
6. Attach the optional conduit box to the top of the battery using the included hardware.
7. Attach the 18kPV to the inverter mounting bracket and ensure the inverter's bottom knockouts align with the conduit box.
8. Finally, properly ground the battery, attaching a grounding conductor to the M6 grounding screw on top of the battery to the Equipment Grounding System.

DO NOT GROUND THE NEGATIVE BATTERY CABLE!

The image to the right represents a completed install showing a rear view.

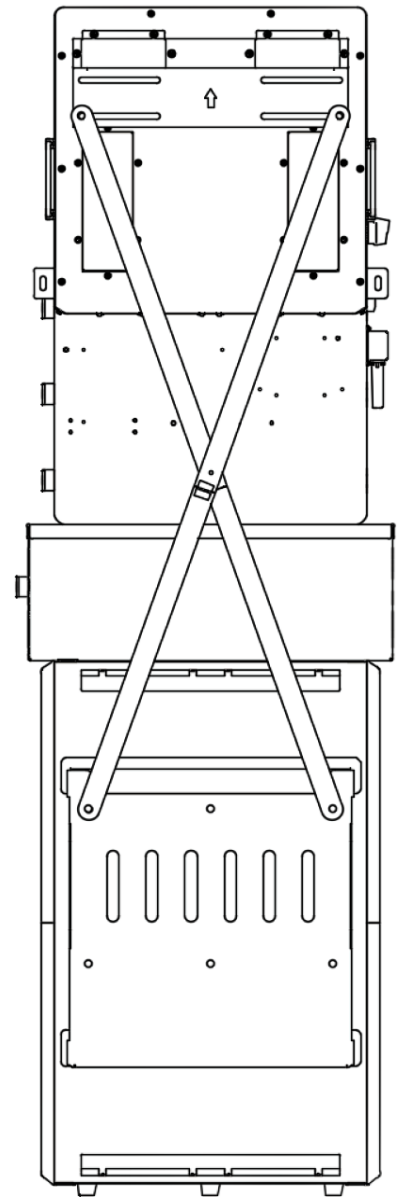

Rear View

6. PRE-WIRE STEPS AND WIRING

Refer to the table below for wire size and torque recommendations for the battery cables.

# OF CABLES	CABLE SIZE	MAX. DISTANCE	TORQUE VALUES
2 sets	1/0 AWG (53.5 mm ²)	10 ft.	Max. 165 in-lbs. (18.6 Nm)
2 sets	2/0 AWG (67.4 mm ²)	20 ft.	Max. 165 in-lbs. (18.6 Nm)
1 set	4/0 AWG (107 mm ²)	10 ft.	Max. 275 in-lbs. (31.1 Nm)
1 set	250 kcmil (127 mm ²)	20 ft.	Max. 275 in-lbs. (31.1 Nm)



IMPORTANT

The battery is capable of charging/discharging up to 200A before the BMS shuts off the pack. Ensure the inverter is configured to handle this high of a current, and size all wires accordingly! Refer to an NEC approved ampacity chart or consult with the installer or a solar electrician for more information.

6.1 MULTIPLE BATTERY PARALLEL INSTALL

When paralleling multiple WallMount All Weather batteries, an optional paralleling kit must be purchased through the distributor.



NOTE: When installing multiple batteries or adding a battery to an existing rack, please ensure all batteries are charged to 100% before paralleling together. This step is crucial to optimize battery performance and ensure proper operation.

Follow the steps outlined below to ensure proper installation of multiple batteries in parallel.

1. Ensure all circuit breakers are open (off). Using a multimeter, check for voltage at all available disconnects and lines. Once no voltage is confirmed, proceed to the next step.
2. Set the DIP switch address on the master battery to address 1, and all other batteries in parallel to differing addresses going in ascending order. (See image) →
3. Reset the battery BMS via the power button to register the address change.
4. Set up communication between the batteries via the “Battery-Com” ports by using a CAT 5, 5e, or 6 cable. Refer to the image below for an example.

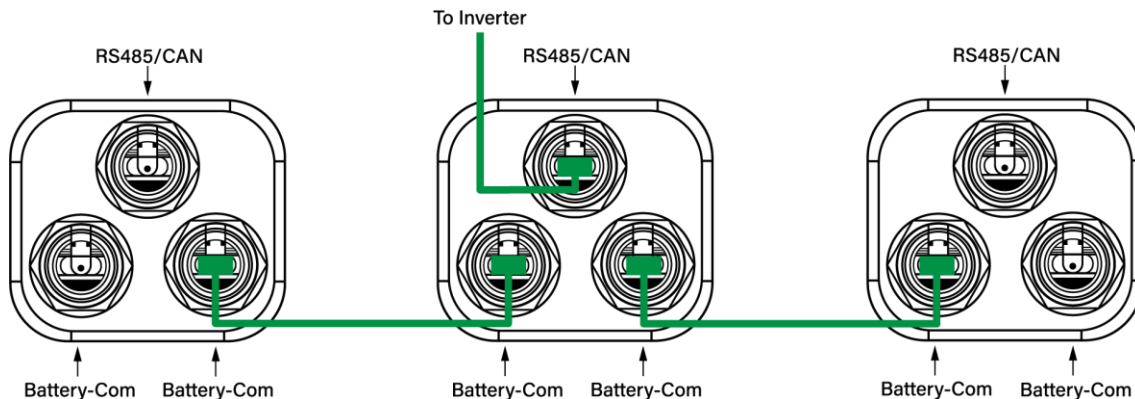

5. The battery set to address 1 will connect directly to the inverter BMS communication port via CAT 5, 5e or CAT 6 cable.
6. Install battery paralleling cables between the batteries included in the optional paralleling kit ensuring the connectors are seated properly.

6.2 MULTIMETER TESTING AND WIRING

Follow the steps outlined below to both test the inputs and wire the battery pack to the inverter.

1. Ensure all circuit breakers are open (off). Using a multimeter, check for voltage at all available disconnects and lines. Once no voltage is confirmed, proceed to the next step.
2. Connect the included sets of 2/0 AWG (70mm²) with outdoor rated connectors to the battery's positive and negative terminals. The connectors will "click" when seated properly.



NOTE: *If installing the battery pack with the optional conduit box, secure the conduit fittings to the enclosure using the counter nuts after step 2.*

3. If applicable, route the battery power cables through the conduit box to the inverter **without making any connections!**



DANGER!

No connections should be made until proper polarity of cables has been confirmed!

4. Ensure proper polarity of cables. Once confirmed, proceed to the next step.
5. Install the 2 positive battery cables to the inverter's positive battery terminals following proper torque values.
6. Install the 2 negative battery cables to the inverter's negative battery terminals following proper torque values.

7. BMS COMMUNICATIONS

EG4 batteries interface with compatible inverters by designating a "Master" battery (DIP switch ID No. 1).





The battery will connect directly to the inverter via an RS485 battery communications cable or a standard CAT 5, 5e, or 6 cable for closed loop communications with supported EG4 and non-EG4 inverters using CAN bus protocol.

The PC software "BMS TOOLS" provides real-time battery analysis and diagnostics. The battery cannot communicate with the software and a closed loop inverter simultaneously.

Scan the QR code for a white sheet walking through the BMS Tools setup process.

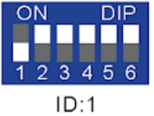

7.1 CLOSED LOOP COMMUNICATIONS

1. Power off all battery DC breakers and BMS power buttons.
2. The inverter protocol can only be changed with the master battery temporarily set to address 64 (all switches ON). After the DIP switch is changed, restart the BMS using the BMS power button for the settings to take effect. (See image) 
3. On the master battery, press and hold the “Return”  key for 5 seconds and release to enter the “Protocol Setting” menu.
4. Select the corresponding CAN protocol (P01-EG4/LUX) for the system if using EG4 inverters, (See table below).
5. Change the master DIP switch address back to address 1 for inverter communications & power cycle the BMS. (See image) 

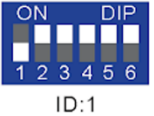

The tables below show compatibility lists depending on the type of communication protocol used for closed-loop communications between battery and inverter.

CLOSED LOOP COMMS. WITH EG4 INVERTERS	
MODEL	PROTOCOL SELECTION
18kPV	CAN – P01
6000XP	CAN – P01
8k Hybrid	CAN – P01
6000-EX	RS485 – P01*
6500-EX	RS485 – P01*
3000EHV	RS485 – P01*

CAN PROTOCOL LIST	
PROTOCOL #	MANUFACTURER
P01-EG4/LUX	EG4/LUX
P02-GRW	Growatt
P03-SLK	Sol-Ark
P04-DY	Deye
P05-MGR	Megarevo
P06-VCT	Victron
P07-LUX	Luxpower
P08-SMA	SMA

RS485 PROTOCOL LIST	
PROTOCOL #	MANUFACTURER
P01-EG4	EG4
P02-GRW	Growatt
P03-SLK	Sol-Ark
P04-SCH	Schneider



***NOTE:** Closed loop communications using RS485 protocols require a specific pinout on the comms cable from battery to inverter. Refer to the table below for EG4 specifics.

EG4 INVERTER MODEL	COMMUNICATION CABLE PINOUT
3000EHV	To Inverter – USB Type B To Battery – RJ45 Pins 1-B & 2-A
6000EX	To Inverter – RJ45 Pins 3 & 5 To Battery – RJ45 Pins 1-B & 2-A
6500EX	To Inverter – RJ45 Pins 3 & 5 To Battery – RJ45 Pins 1-B & 2-A

8. FIRMWARE UPDATES

Always ensure all system components are fully up to date before commissioning the system. Navigate to [the EG4 WallMount All Weather product page](#) to find the latest downloads for the battery. A PDF walkthrough will be included in the downloaded .zip file.

If encountering difficulties during the updating process, contact the distributor for more information.

9. WARRANTY INFORMATION

For information regarding warranty registration on EG4® Electronics products, please navigate to <https://eg4electronics.com/warranty/> and select the corresponding product to begin the registration process.

10. CHANGELOG

Version 1.1.2

- Added new spacing requirements from 12 in. to 6 in.

11-12-24 | v1.1.1

- Modified warranty in section 9.



CONTACT US

support@eg4electronics.com

(903) 609-1988

www.eg4electronics.com