

INSTALLATION INSTRUCTIONS BRIGHTMOUNT



SOLAR GROUND MOUNT SYSTEM

SCAN FOR UPDATED
DOCUMENTS



TABLE OF CONTENTS

1.	INTRODUCTION	1
2.	PACKING LIST	1
3.	ENGINEERING DRAWINGS	2
4.	LAYOUT AND INSTALLATION INFO.....	3
4.1	OVERALL LAYOUT	3
4.2	TOOLS NEEDED.....	3
4.3	TORQUE VALUES	3
5.	INSTALLATION INSTRUCTIONS	4
5.1	LEG GROUP ASSEMBLY.....	4
5.2	LEG GROUP INSTALLATION	7
5.3	RACK RAIL ASSEMBLY	8
5.4	OPTIONAL BRIGHTMOUNT EXTENSION KIT.....	10
5.4.1	PACKING LIST	10
5.4.2	BRIGHTMOUNT EXTENSION INSTALLATION.....	10
5.5	SOLAR PANEL INSTALLATION	12
5.6	GROUND LUG INSTALLATION	14
5.7	GROUND WIRE INSTALLATION.....	14

1. INTRODUCTION

The EG4 BrightMount Solar Ground Mount is an innovative, heavy duty solar ground mount system designed specifically for ground mounted solar panel arrays. Manufactured from anodized aluminum with stainless steel hardware, this ground mount system is designed for the rigors of outdoor use. Each BrightMount kit comes with everything you need to install up to 4 solar panels side-by-side and the inclination angle can be adjusted to three pre-set angles of 25°, 30°, or 35°.

2. PACKING LIST

The following items are included with the EG4 BrightMount Solar Ground Mount system. Before assembly and installation, please inspect the contents to ensure no components were damaged in transit.

**End Clamp w/ T-slot nut
(30, 35, and 40mm, Qty 4ea.)**



Rack Rail (Qty 4)



Mid Clamp w/ T-slot nut (Qty 8)



**Grounding Lug w/ T-slot nut and
pre-installed ground clip (Qty 2)**



**Leg Group (Qty 4)
(assembly required)**



Anchor Bolt (Qty 16)



“L” Bracket w/ T-slot nut (Qty 8)



**Splice Connector and
Bonding Jumper (Qty 2)**



Grounding Clip (Qty 6)



3. ENGINEERING DRAWINGS

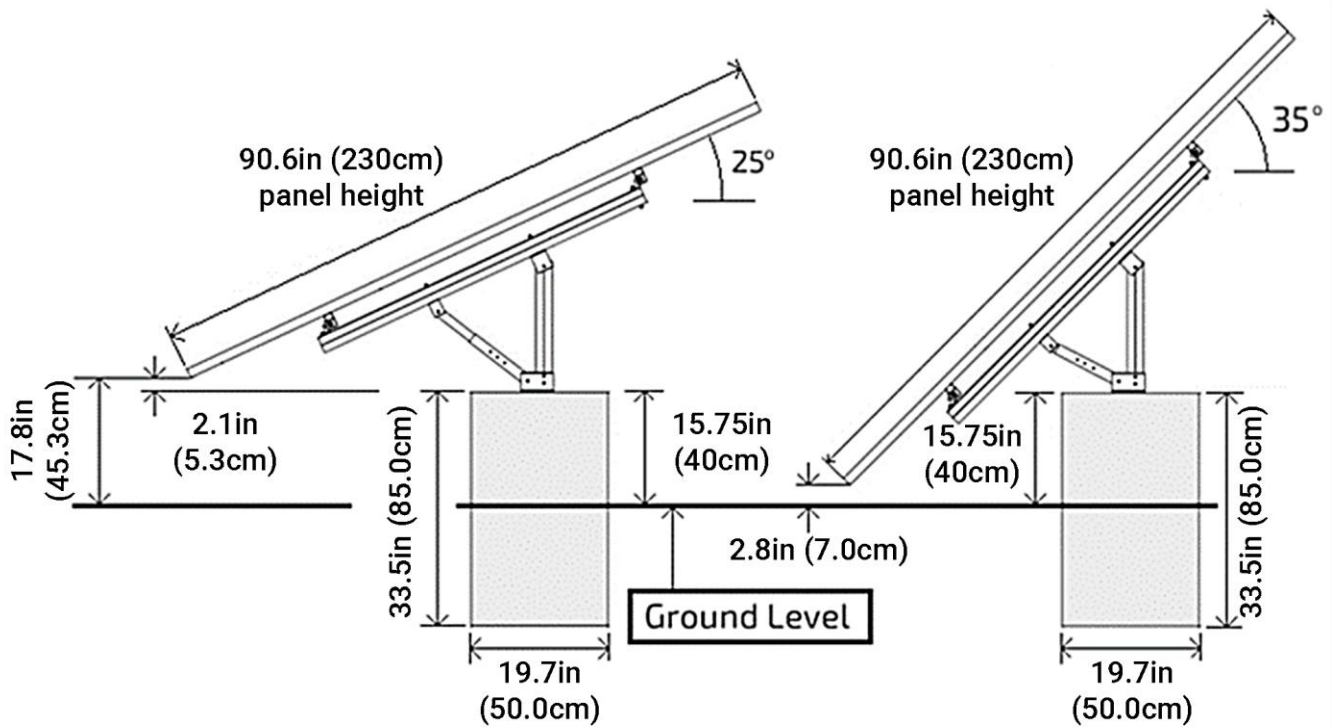
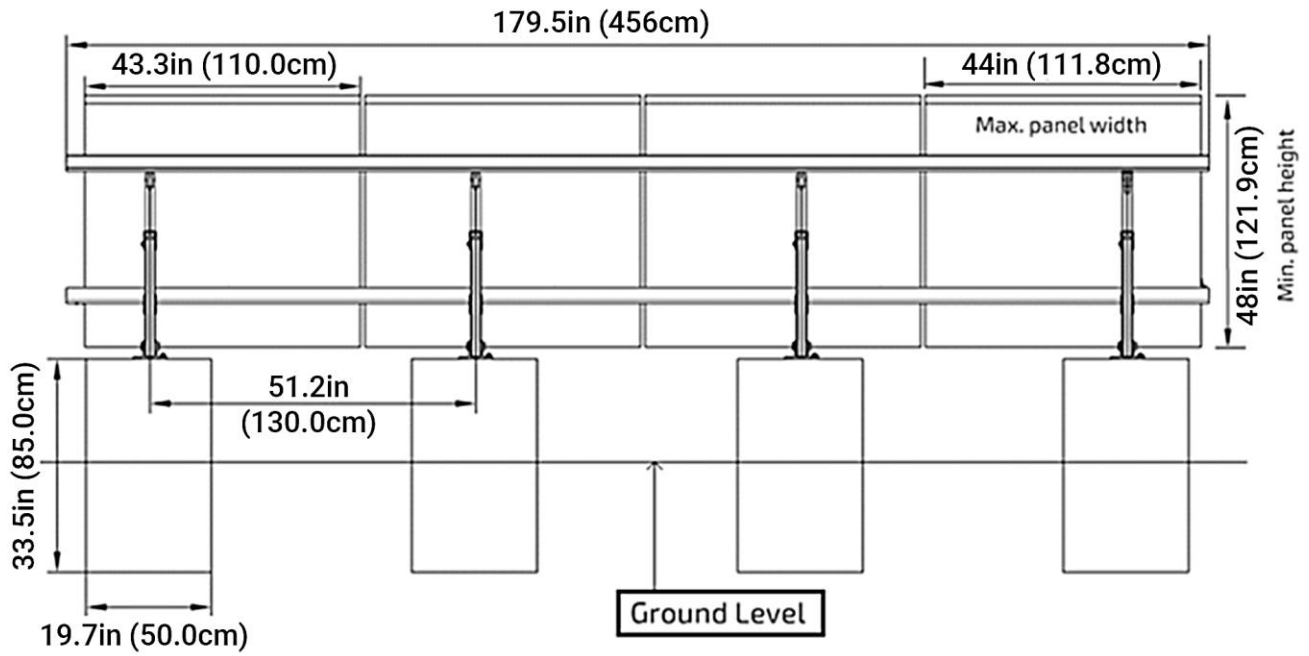

4. LAYOUT AND INSTALLATION INFO

4.1 OVERALL LAYOUT

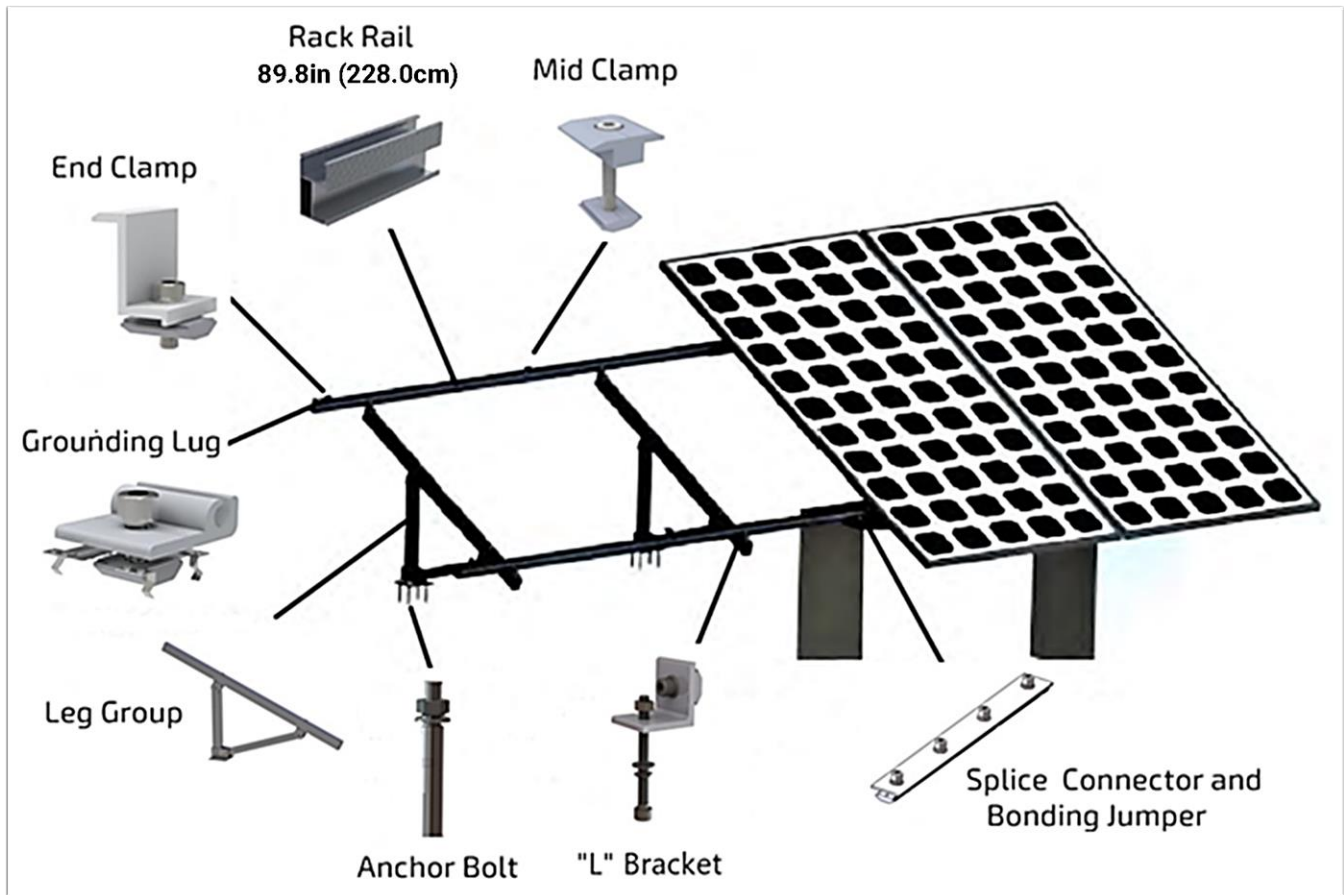

4.2 TOOLS NEEDED



4.3 TORQUE VALUES

FASTENER	RECOMMENDED TORQUE
M10 Bolt + M10 Nut	228 in-lbs (25.8 Nm)
M8 Bolt + M8 Nut	115 in-lbs (13 Nm)
M8 Bolt + T-slot Nut	97 in-lbs (11 Nm)
M8x10mm Set Screw	80 in-lbs (9 Nm)

5. INSTALLATION INSTRUCTIONS

5.1 LEG GROUP ASSEMBLY

Each leg group is made up of the following parts:

- One (1) 2.4x1.5x51.2in. (6x3.8x130cm) extruded aluminum main beam.
- One (1) 2.4x1.5x18.5in. (6x3.8x47cm) extruded aluminum leg.
- One (1) 1.5x1.5x14.8-17.3in. (3.8x3.8x37.5-44cm) telescoping aluminum leg (*).
- One (1) 5.3x4.7x2.8in. (13.5x12x7cm) main base bracket.
- One (1) large 2.8x2.4x1.9in. (7x6x4.9cm) aluminum U-bracket.
- One (1) small 2.2x1.6x1.7in. (5.5x4x4.2cm) aluminum U-bracket.
- Two (2) M8x80mm stainless steel bolts with 6mm Allen head.
- Four (4) M8x70mm stainless steel bolts with 6mm Allen head.
- Two (2) M8x55mm stainless steel bolts with 6mm Allen head.
- Sixteen (16) M8 stainless steel flat washers.
- Eight (8) M8 stainless steel spring washers.
- Eight (8) M8 stainless steel 13mm hex nuts.



(*) HELPFUL TIP: The telescoping leg can be adjusted to three preset lengths of 14.7in. (37.5cm), 16.1in. (41cm), and 17.3in. (44cm), each corresponding to a fixed solar panel angle on level ground of 35°, 30°, and 25°, respectively.

STEP 1: Attach the two U-brackets to the 51.2in. (130cm) extruded aluminum main beam as shown in the figure below. The order of U-bracket mounting is irrelevant as the main beam is symmetric. Each U-bracket requires one M8x80mm bolt with a flat washer secured with one flat washer, one spring washer, and one 13mm hex nut. Hold the M8x80mm bolt head with a 6mm Allen wrench and torque the 13mm nut to 115 in-lbs (13 Nm).

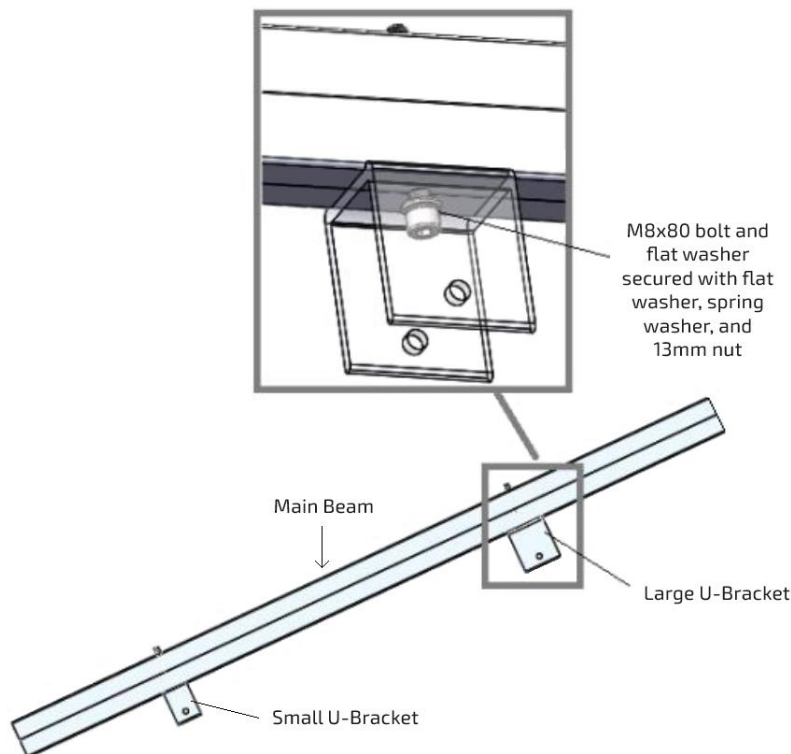

STEP 2: Assemble the remainder of the leg group according to the figure below. Do not tighten the hardware until the unit is completely assembled and have decided on the final angle of the solar array. Step 3 below describes how to adjust the array angle on each leg group. All leg groups in an array must be set to the same angle.

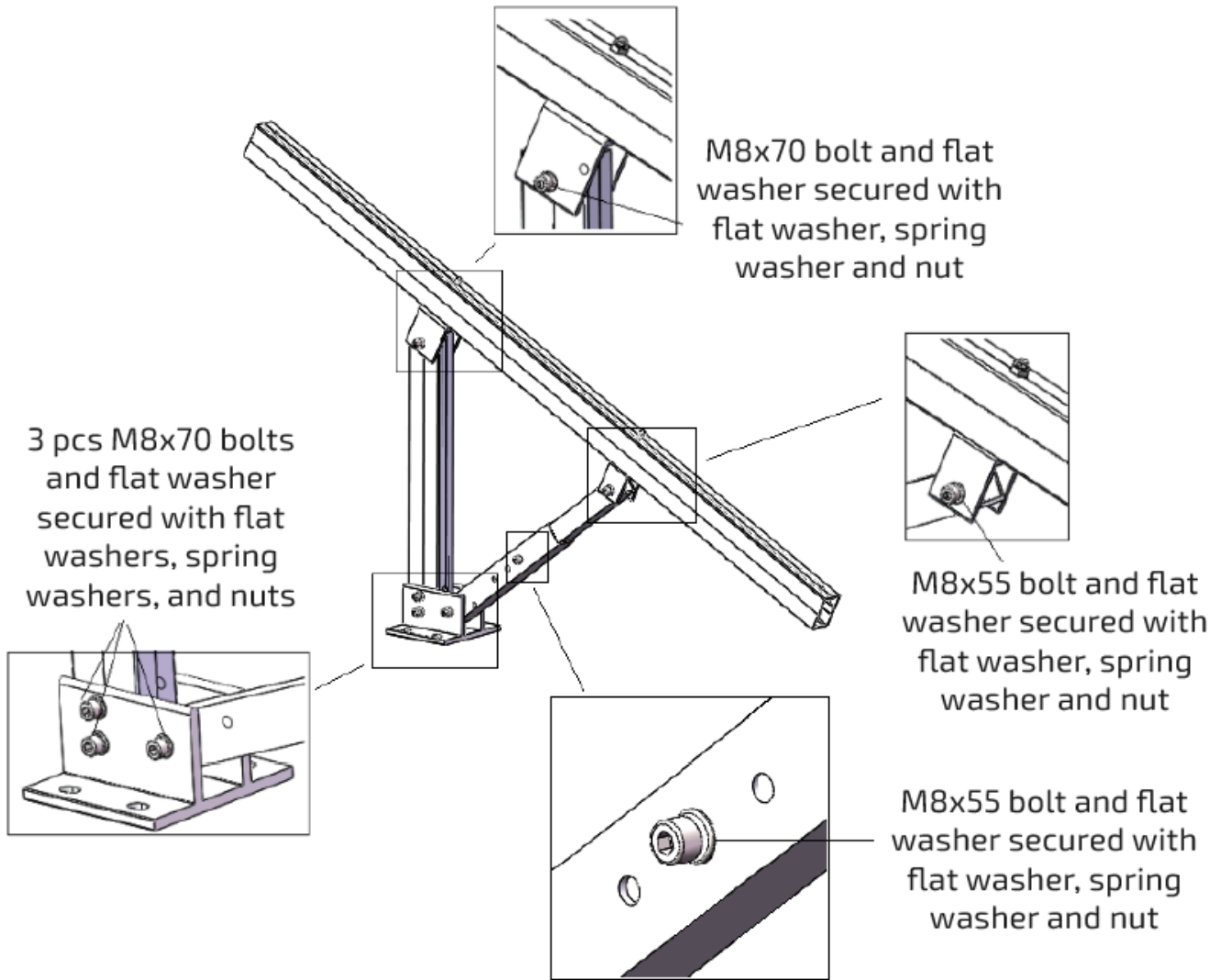

STEP 3: The telescoping aluminum leg can be adjusted to create different angles of inclination to maximize solar energy transfer. The inner section of the telescoping leg has one hole, and the outer section has three holes. By aligning the hole in the inner section with one of the holes in the outer section, three different fixed angles can be configured (see figure to the right and table below).

ANGLE	LENGTH (L)
25°	17.4 in. (44.2 cm)
30°	16.1 in. (41.0 cm)
35°	14.7 in. (37.4 cm)

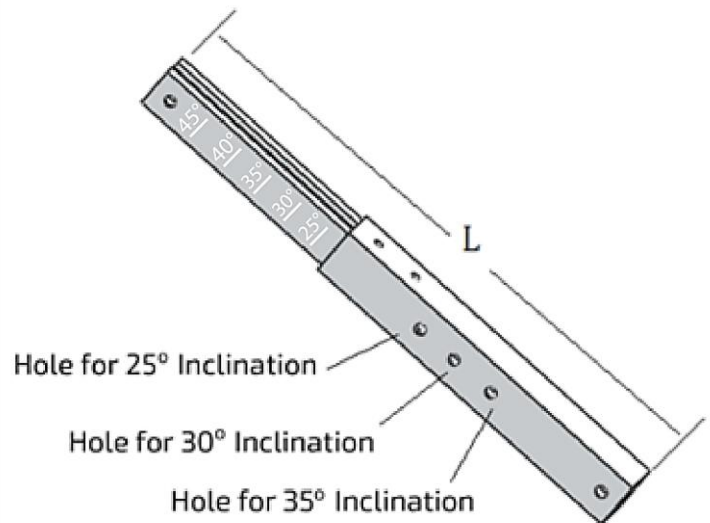

NOTE: A 4mm Allen head wrench can be used to tighten the two M8x10mm set screws in the telescoping leg. These set screws can be used to temporarily set and hold a specific angle; however, they should NOT be used to permanently secure the telescoping leg. An M8x55mm bolt with flat washer must be inserted into the aligned holes and secured with a flat washer, spring washer and nut for long term mechanical stability under heavy wind loads.



After aligning the holes for the desired angle, insert an M8x55mm bolt with a flat washer through the aligned holes and secure with an M8 flat washer, spring washer, and nut. See the figure to the right.

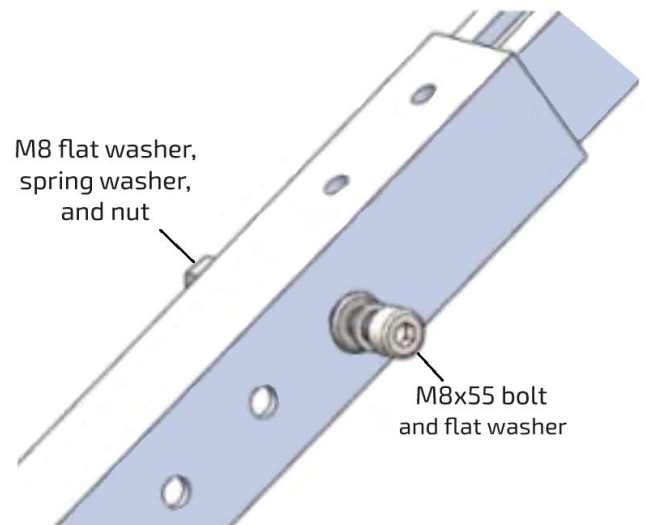

NOTE: Hold the M8x55mm bolt head with a 6mm Allen wrench and torque the 13mm nut to 115 in-lbs. (13Nm).



NOTE: After fixing the leg group angle in Step 3 above, tighten all leg group hardware. Hold the M8 bolt heads with a 6mm Allen wrench and torque the 13mm nuts to 115 in-lbs. (13Nm).

STEP 4: Install an “L” bracket on each end of the main beam as shown in the figure below. Secure the “L” brackets to the main beam using an M8x80mm bolt and flat washer secured with a flat washer, a spring washer, and a 13mm hex nut. Hold the M8x80mm bolt head with a 6mm Allen wrench and torque the 13mm nut to 115 in.-lbs. (13Nm).

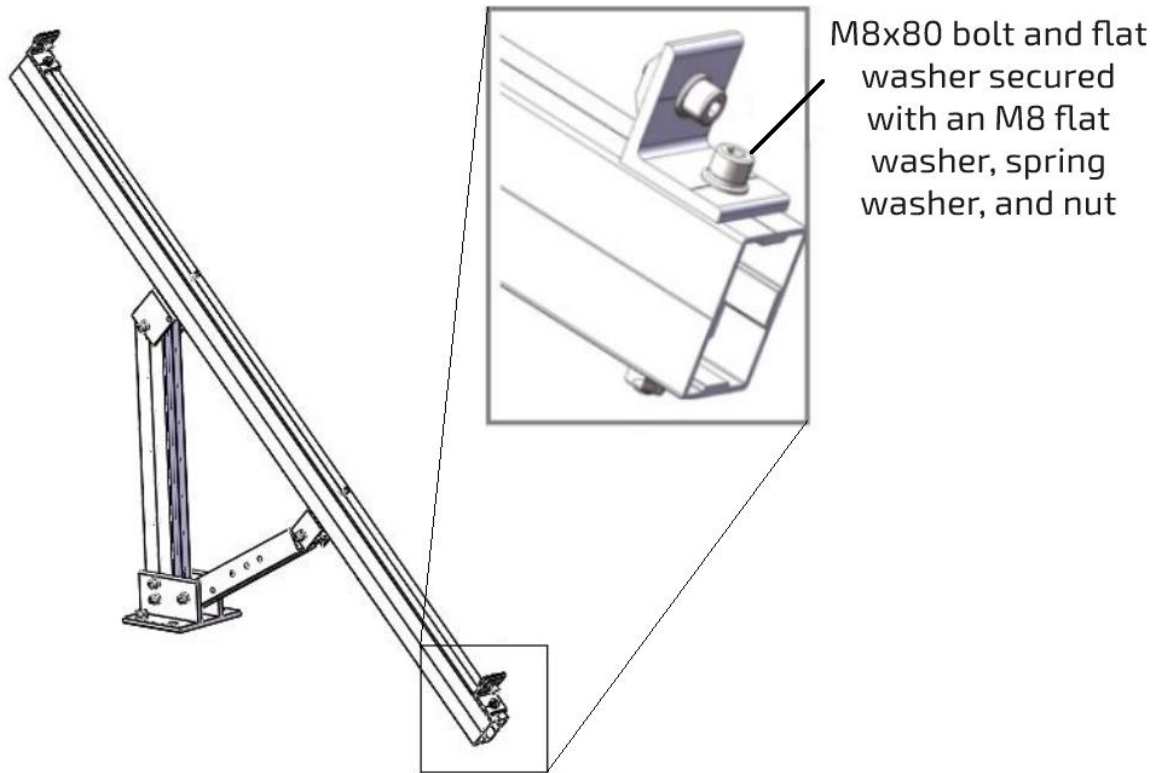

5.2 LEG GROUP INSTALLATION

Each leg group requires a concrete base to provide a solid foundation that will resist movement due to heavy winds. The dimensions of each base should be 19.7x19.7x33.3in. (50x50x85cm) with 17.7 in. (45cm) of each base below ground level.

STEP 1: Pour concrete bases for each leg group according to the figure below. The bases should be 51.2 in. (130cm) apart, center-to-center.

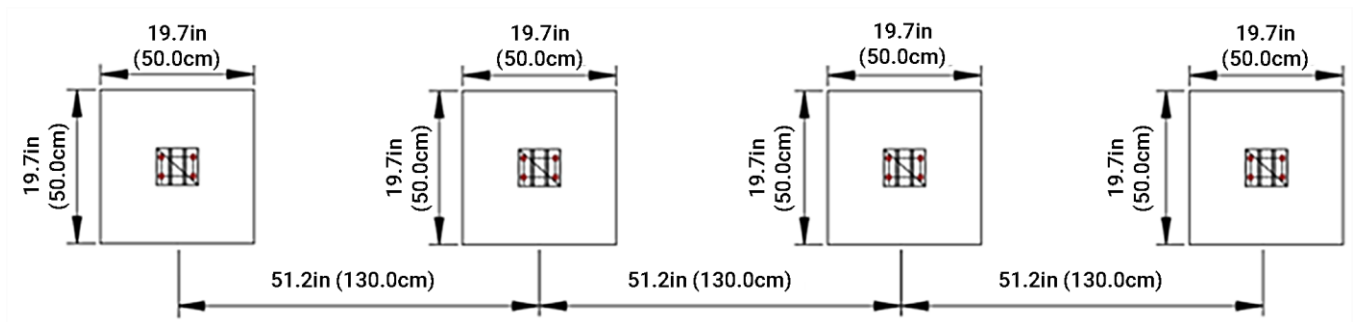

STEP 2: The detailed top-down view of a concrete base, shown below, indicates the mounting location, orientation, and dimensions for the leg group main base bracket. After the concrete bases have dried sufficiently, use the main base bracket as a template to mark the correct hole locations on the top of each base. Drill four (4) 0.5in. (1.25cm) diameter by 3in. (7.6cm) deep holes. Install the four (4) M10x100mm concrete expansion bolts into the holes **without the flat washer, spring washer, and hex nut** (these are installed and tightened after the leg group is installed).

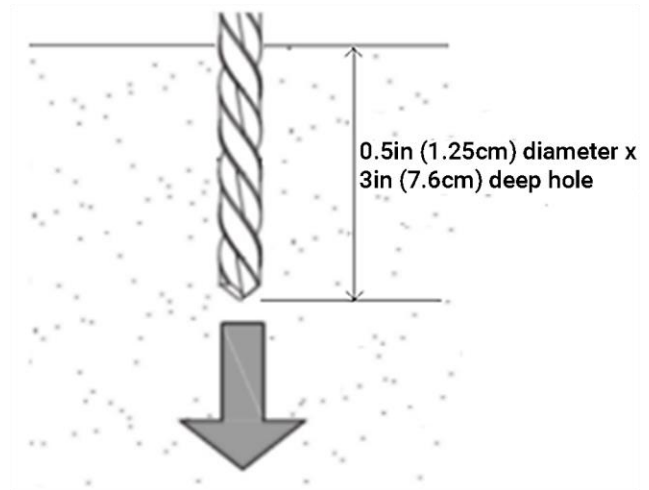
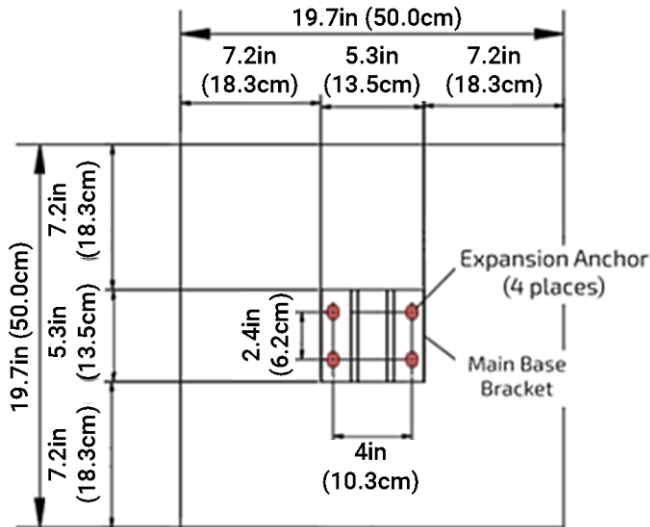

STEP 3: Install a leg group on top of each base by placing the main base bracket over the four anchor bolts installed in Step 2. Install a flat washer, spring washer, and 17mm nut on each anchor bolt and torque the 17mm nuts to 228 in-lbs. (25.8Nm).

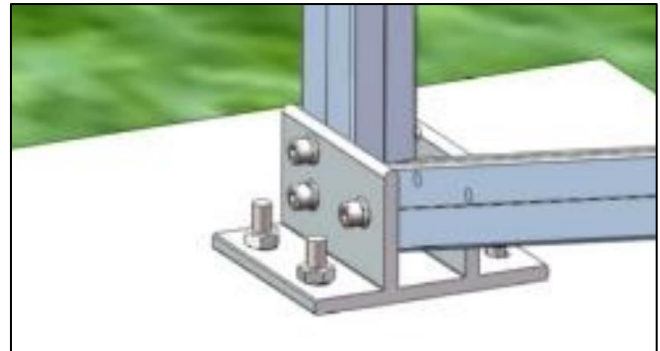

5.3 RACK RAIL ASSEMBLY

The following figures provide examples of how to install the various clamps onto the BrightMount rack rails and secure them with the set screws.

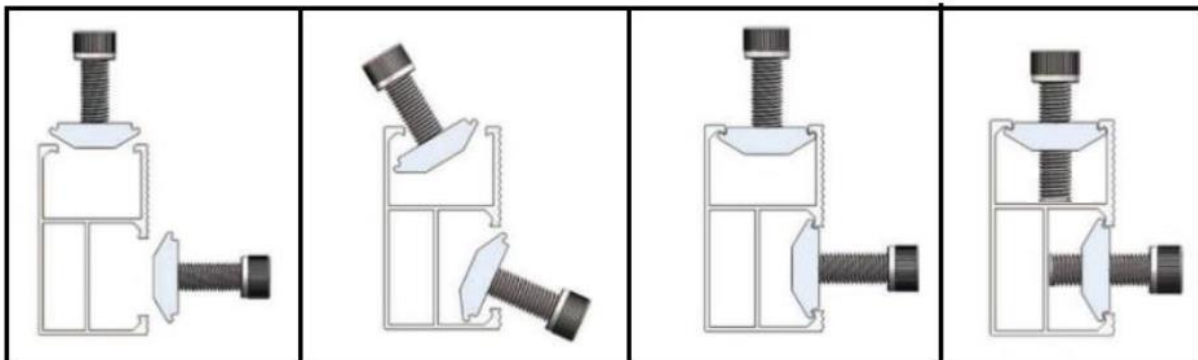

STEP 1: Attach the rack rails to the leg groups using the “L” bracket on each end as shown below,

- a) Align the rack rail with the leg group “L” bracket.
- b) Attach the rack rail to the leg group “L” bracket.
- c) Ensure the rack rail is aligned properly and torque the “L” bracket fasteners to 97 in-lbs. (11Nm).

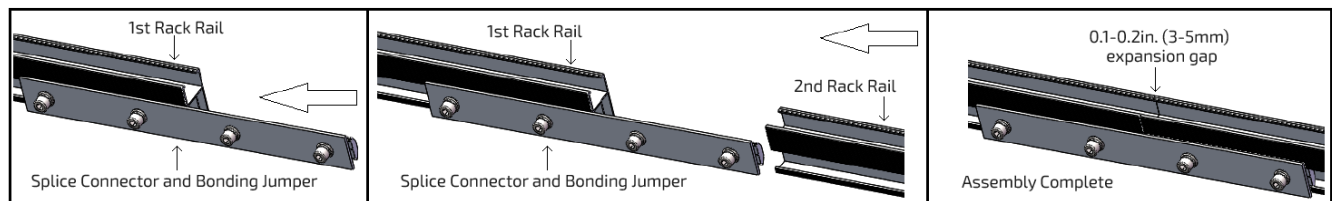
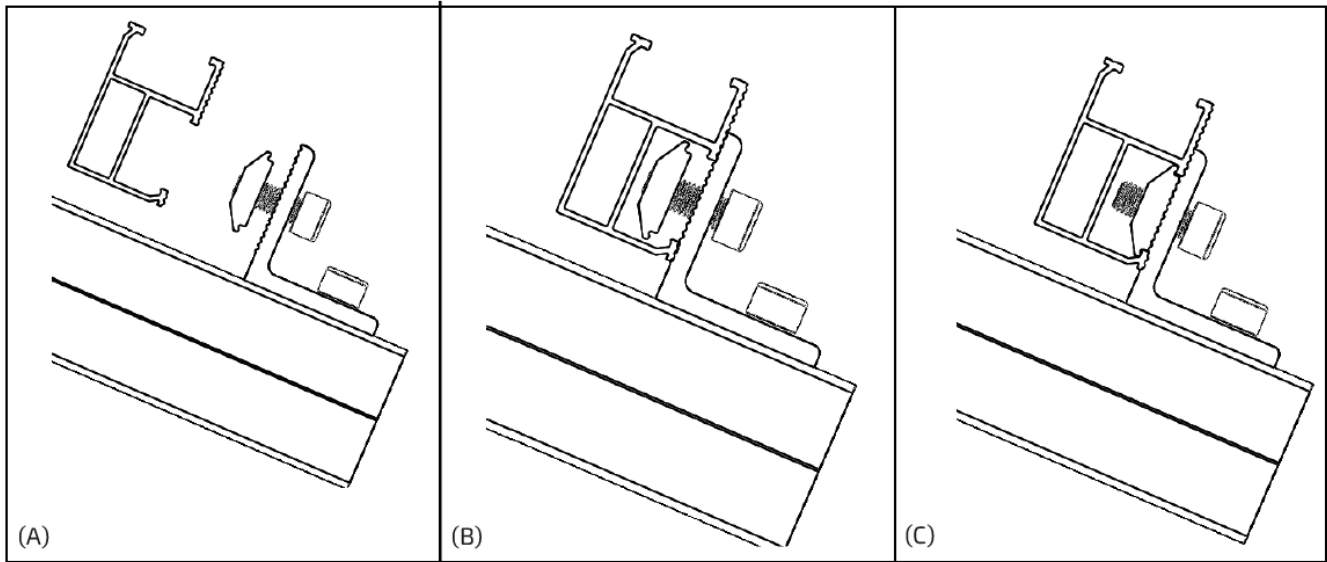

Note: If purchasing the optional BrightMount Extension Kit go to Section 5.4.2 for installation.

STEP 2: The figure above shows how to connect rack rails to each other using the splice connector and bonding jumper. It is recommended that a 0.1-0.2in. (0.3-0.5cm) gap be left between the rack rails to allow for thermal expansion and contraction in the final assembly. Torque all splice connector and bonding jumper fasteners to 97 in-lbs (11Nm).



NOTE: Each fastener on the splice connector and bonding jumper has an integrated circular grounding shim. Ensure the grounding shims are between the splice connector flat bar and the outside of the rack rail as shown in the figure to the right. This will ensure proper grounding of all solar rack rails.

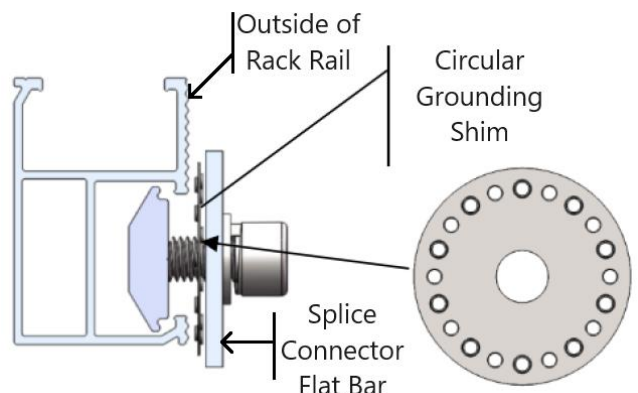

WARNING: Failure to properly ground the rack rails may adversely impact the operation of your solar system.

The final assembly should appear similar to the following:

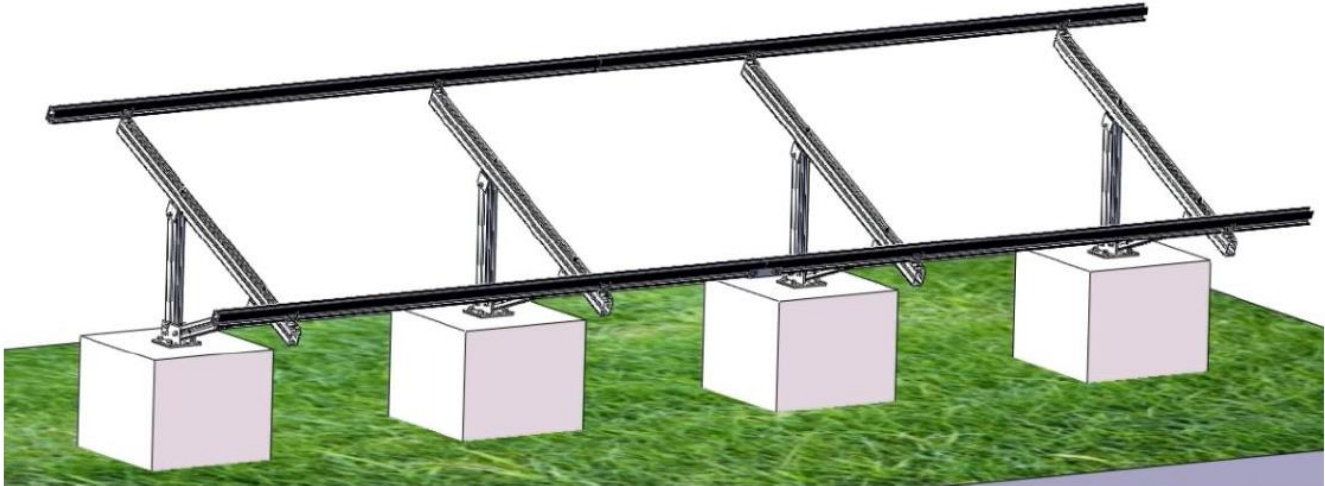

5.4 OPTIONAL BRIGHTMOUNT EXTENSION KIT

When purchasing the Brightmount Solar Ground Mount, there will be an option to add the Brightmount Extension Kit. This kit will allow the horizontal rails that support the panels to extend an additional 5 in.(12.9cm) between the connection points of both horizontal rails. Not all panels are the same, some are wider than others. This is the solution for wider panels that did not fit on the ground mount before. The packing list and installation instructions needed to complete the extension on the ground mount are below.

5.4.1 PACKING LIST

**5" Rack Rail Extension
(Qty 2)**

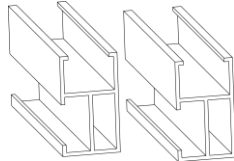

**13" Rail Tube Bar
(Qty 2)**

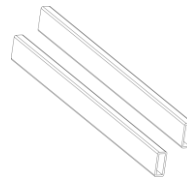

Note: Depending on the unit purchased, some earlier versions of the BrightMount Solar Ground Mount Systems will come with a 5.5in.(14cm) splice connector/bonding jumper. The more recently purchased BrightMount systems come with a 13.5in.(34.3cm) connector/jumper. The 13.5in.(34.3cm) connector/jumper allows users to extend their system. If users received the version with the 5.5in.(14cm) connector/jumper and wish to extend their system, the 13.5in.(34.3cm) is available separately for purchase. Multiple BrightMount systems can be spliced together with the 13.5in.(34.3cm) connector/jumper.

5.4.2 BRIGHTMOUNT EXTENSION INSTALLATION

The figure below shows how to connect the extension rack rail and rail tube bar to each other using the splice connector and bonding jumper.

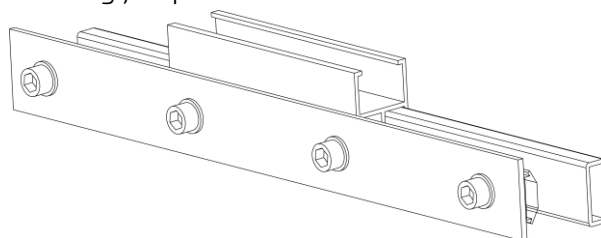

STEP 1: Before proceeding with connecting the rails together with the splice connector and bonding jumper. Take one rail and one rail tube bar, that are already assembled, and insert the rail tube bar into the 1st rack rail with the splice connector and bonding jumper attached.

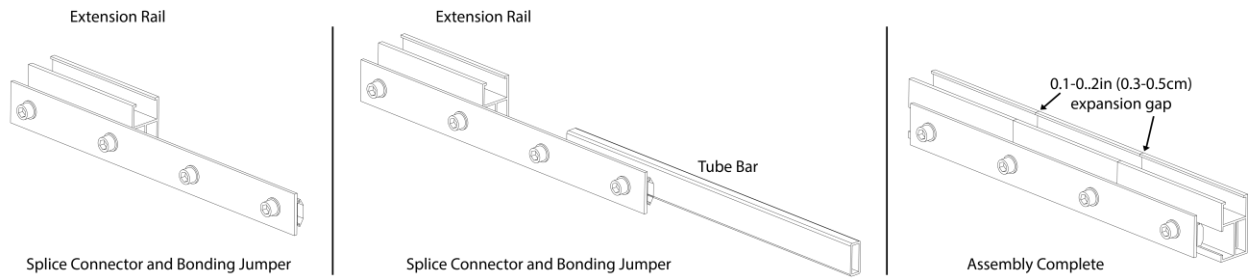

STEP 2: After completing Step 1 take the other end of the rail and rail tube bar and insert it into the 2nd rack rail. Once the rack rails and bars are assembled. It is recommended that a 0.1-0.2in. (0.3-0.5cm) gap be left between the rack rails to allow for thermal expansion and contraction in the final assembly. Torque all splice connector and bonding jumper fasteners to 97 in-lbs (11Nm).

The final assembly should appear similar to the following:

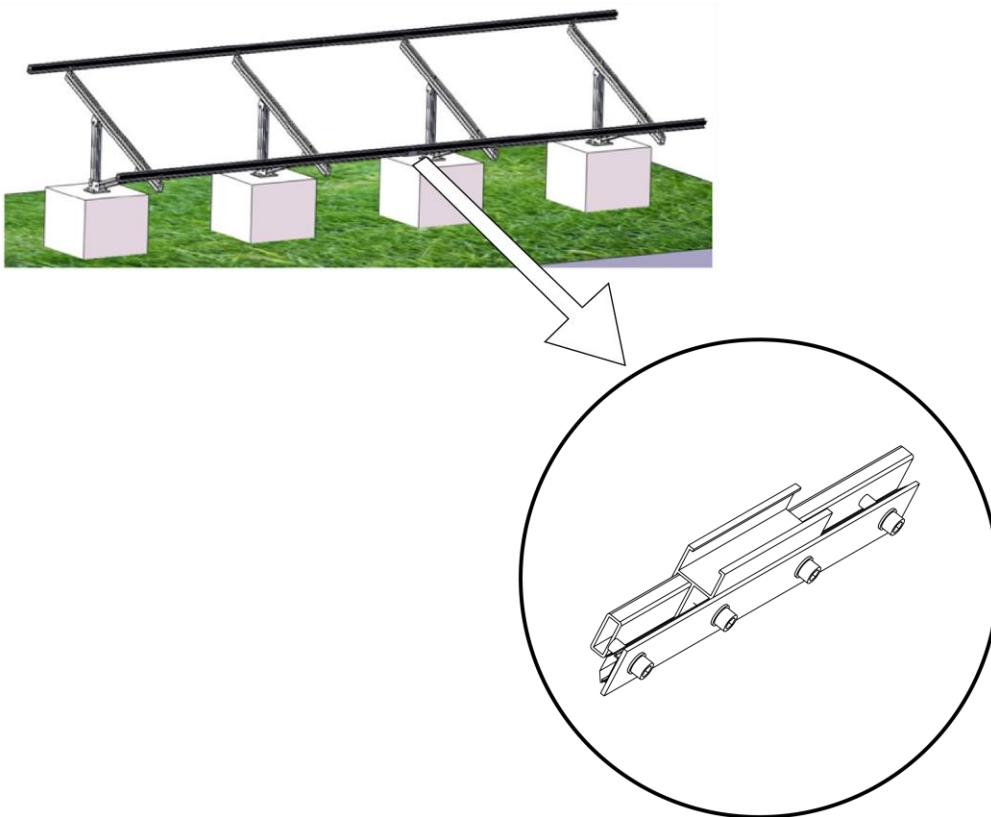

5.5 SOLAR PANEL INSTALLATION

The solar panels should be installed in the “portrait” orientation with the top and bottom of each panel extending above and below the top and bottom rack rail, respectively, (i.e. the top and bottom of the panels should overlap the rack rails the same amount so that the panels are approximately centered top-to-bottom on the rack rails).



IMPORTANT:

- These instructions describe solar panel installation from left to right with panels in the “portrait” orientation.
- There are three different size end clamps: 1.18, 1.38, and 1.57in. (3, 3.5, and 4cm). Ensure the end clamps used are properly sized for the solar panels being installed.
- Panels mounted on the end of the BrightMount rack system will require two end clamps and two mid clamps.
- Panels mounted between other panels will require four mid clamps.
- Mid clamps are shared between adjacent panels and can be adjusted to accommodate panel thicknesses of 1.18, 1.38, and 1.57in. (3, 3.5, and 4cm).
- Mid clamps require a grounding clip.
- End clamps do not require a grounding clip.

STEP 1: Using the team-lift technique, center the solar panel on the upper and lower rack rails. While the panel is held in place, install two end clamps on the left side of the panel as described below.

- a) Referencing the following figure, insert end clamps into the end of both rack rails.
- b) Push the end clamp against the solar panel so that the top of the end clamp overlaps the top of the solar panel, and the body of the clamp is flush against the side of the solar panel.
- c) Tighten the end clamp fasteners, but do not apply torque until all clamps and panels are installed.

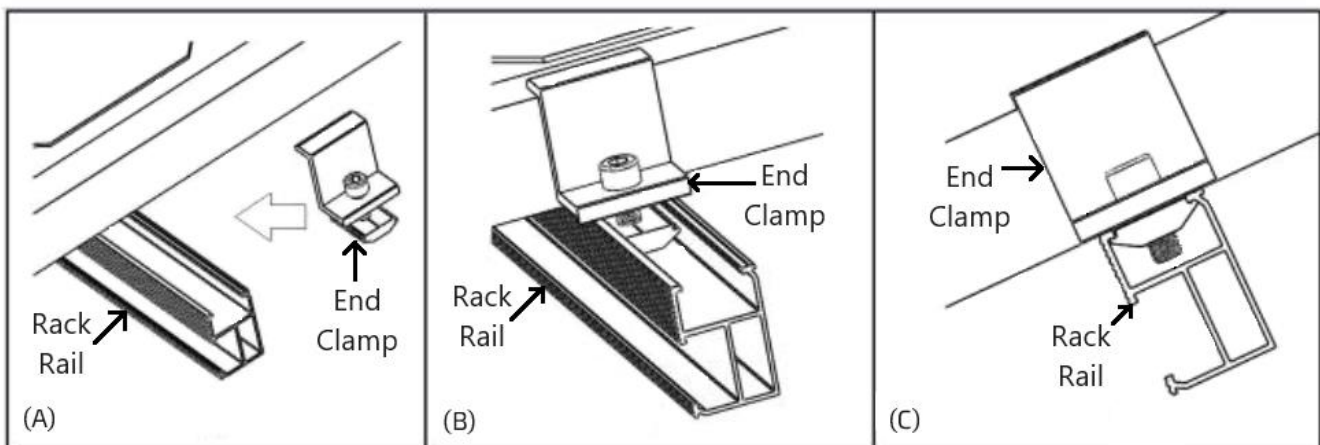

STEP 2: Install two mid clamps on the right side of the panel as described below.

- a) Referencing the figure below, insert mid clamps with grounding clips onto both rack rails.
- b) Push the mid clamps against the panel so that the mid clamps overlap the top of the panel, and the body of the clamps are flush against the side of the panel. The grounding clip must be between the top of the rack rail and the bottom of the panel for proper grounding.
- c) Mid clamps are shared between adjacent panels. Tighten the mid clamp fasteners to hold the panel in place, but do not torque the mid clamps until all panels are installed. Figure (C) below shows a semi-transparent view of two adjacent panels and one mid clamp.

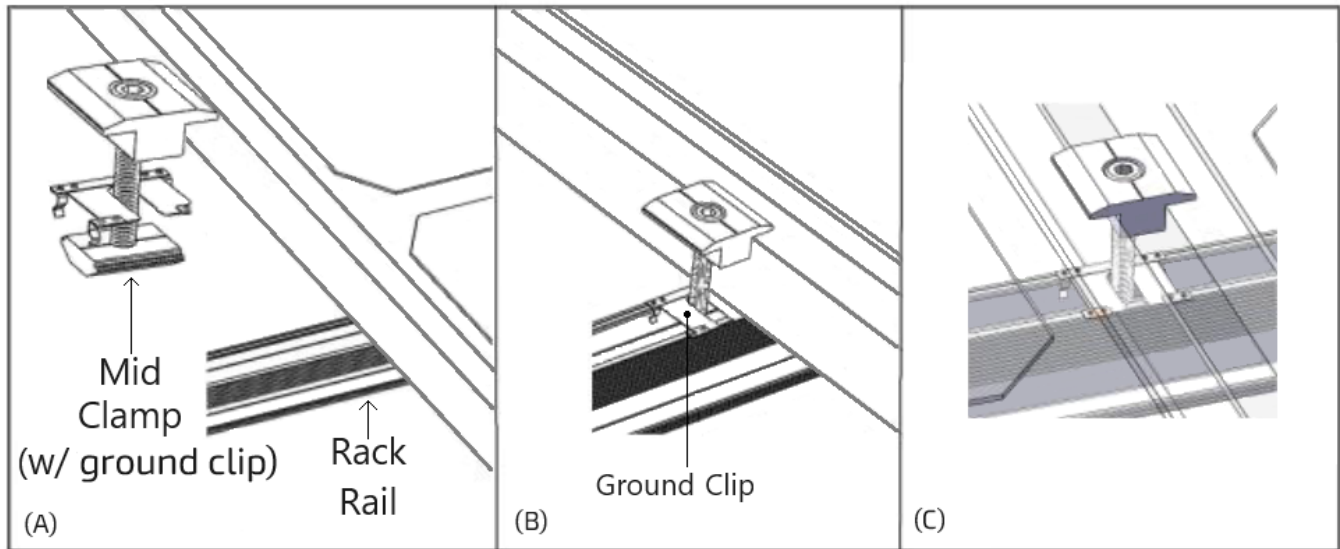

NOTE: Each mid clamp must have a grounding clip as shown above. Ensure the grounding clips are installed between the bottom of the solar panel and the top of the rack rail. This will ensure proper grounding of all solar panels.



WARNING: Failure to properly ground the solar panels may adversely impact the operation of your solar system.

STEP 3: Repeat Steps 1 and 2 above for the remaining solar panels. When installing four (4) solar panels, the left-most and right-most panels will require two (2) end clamps and two (2) mid clamps. The middle panels will require four (4) mid clamps, but mid clamps are shared between adjacent panels as shown in Figure (C) above.

STEP 4: After installing all solar panels, make any final adjustments to the panel positions and torque all end clamps and mid clamps to 97 in-lbs (11Nm).

5.6 GROUND LUG INSTALLATION

Install grounding lugs (with pre-installed grounding clips) on the end of the top and bottom rack rails as described below,

- a) Referencing the figure below, align grounding lugs with the end of both rack rails.
- b) Install grounding lugs at the end of both rack rails and ensure the ground clips are between the bottom of the ground lugs and the top of the rack rails. Torque the fasteners to 97 in-lbs (11Nm)

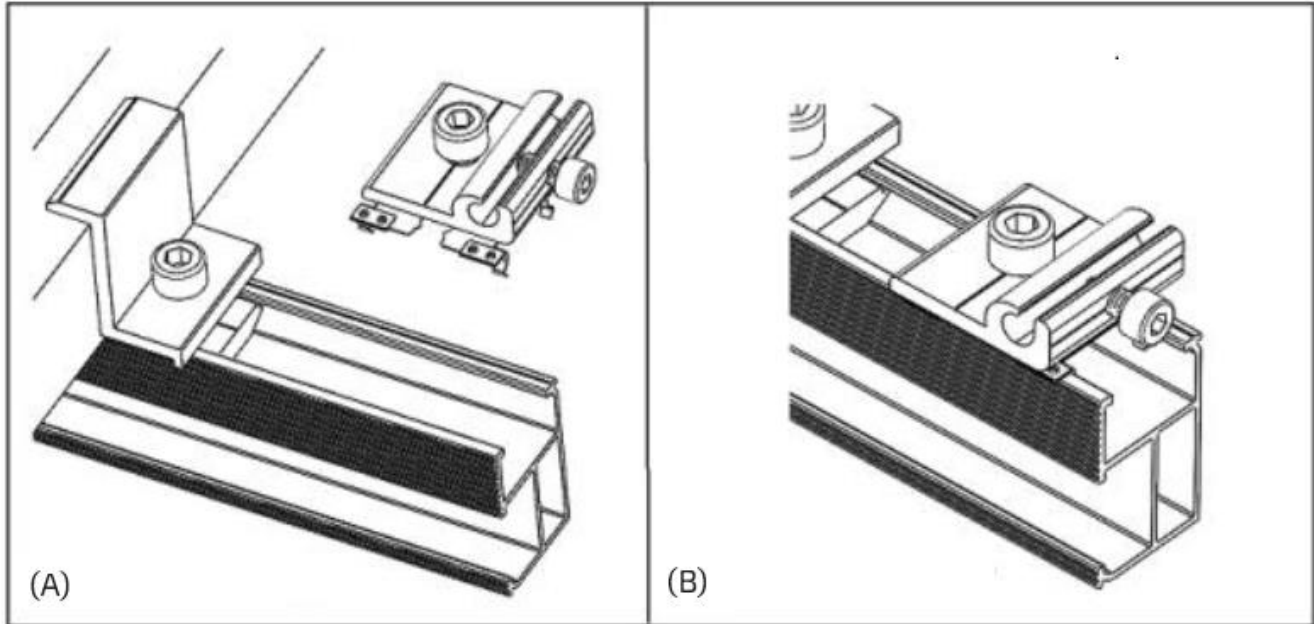

NOTE: As shown in the previous figure, it is highly recommended that both the top and bottom rack rails be grounded to earth using grounding lugs.



NOTE: Each grounding lug must have a grounding clip. Ensure the grounding clips are installed between the bottom of the grounding lug and the top of the rack rail. This will ensure proper grounding of all solar panels.

5.7 GROUND WIRE INSTALLATION

After installing a grounding lug on the end of both rack rails, use a properly gauged ground wire (e.g. 6-4 AWG) to connect the rack rails to earth ground.



WARNING: Failure to properly ground the BrightMount Solar Ground Mount System may adversely impact the operation of your solar system.



CONTACT US

support@eg4electronics.com

(903) 609-1988

www.eg4electronics.com