

EG4 Waterproof Battery 48V 100Ah



User Manual

1.1.0

Table of Contents

About This Manual.....	2
Introduction.....	3
Installation.....	4
Charging.....	4
Introduction to the BMS.....	5
Battery Module Performance Curve.....	6
Battery Storage.....	7
Battery End of Life.....	7
Warranty.....	8

About This Manual

Purpose

This manual describes installation, commissioning, operation, and troubleshooting. Please read the manual fully and carefully before installing and operating. Keep this manual for future use.

Scope

This manual provides basic installation guidelines as well as information on tools and wiring.

Safety Notice

Attention: The following contains important safety and operating instructions. Read and keep this manual for future reference.

1. Before installing or using the unit read all instructions and cautionary markings on the unit and all appropriate sections of the manual.
2. CAUTION - Do not disassemble the unit. Take it to a qualified service center when service or repair is required. Incorrect re-assembly may result in a risk of electric shock or fire.
3. To reduce the risk of electric shock, shutdown and disconnect all wiring before attempting any maintenance or cleaning. Turning off the unit alone will not reduce the risk of shock or injury.
4. CAUTION - Only qualified personnel can install this equipment.
5. NEVER charge a battery below the specified minimum temperature; refer to the battery data sheet.
6. Wire size is critical for safe operation, and optimal performance of the equipment. Refer to an accredited sizing resource or cable manufacturer specifications to meet charge/discharge requirements.
7. Use caution when working with metal tools on or around all systems and batteries. Risk of electrical arcs and/or short circuiting of equipment can lead to severe injury and damage.
8. Strictly follow installation procedure when connecting/disconnecting DC terminals. Refer to the Installation section of this manual for details.
9. Size and install the correct overcurrent protection for conductors and battery.
10. Grounding - The grounding system must meet the Authority Having Jurisdiction (AHJ) requirements for your area.
11. NEVER short DC inputs. Do NOT connect the system to the grid with a shorted DC input.
12. WARNING - Only qualified service personnel are able to service this equipment. If errors persist after following the troubleshooting table, please contact your retailer for further assistance.

Introduction

Product Description

EG4-Waterproof-48100 is a 51.2V100Ah Lithium iron phosphate battery module which is designed for energy storage, power supply or UPS, solar system, portable devices, boat, or motive system application. This battery module, integrated with intelligent BMS inside, has big advantages on safety, cycle life, energy density, temperature range and environmental protection. This product specification describes the type, size, structure, electrochemistry performance, service life, and BMS characteristics.

The battery module consists of single LFP cells, wire, BMS and container.

- Packed with high performance LFP single cell, long life, safety and wide temperature range
- High energy density, small size, light weight, no pollution
- Packing with single cell container, fire retardant wire and laser welding, stable and safe
- Built-in BMS, with battery voltage, current, temperature and health management
- Integrated Bluetooth inside, customized APP for battery monitoring
- Flexible customization of dimensions
- More than 15 years design life
- Stable performance, maintenance-free

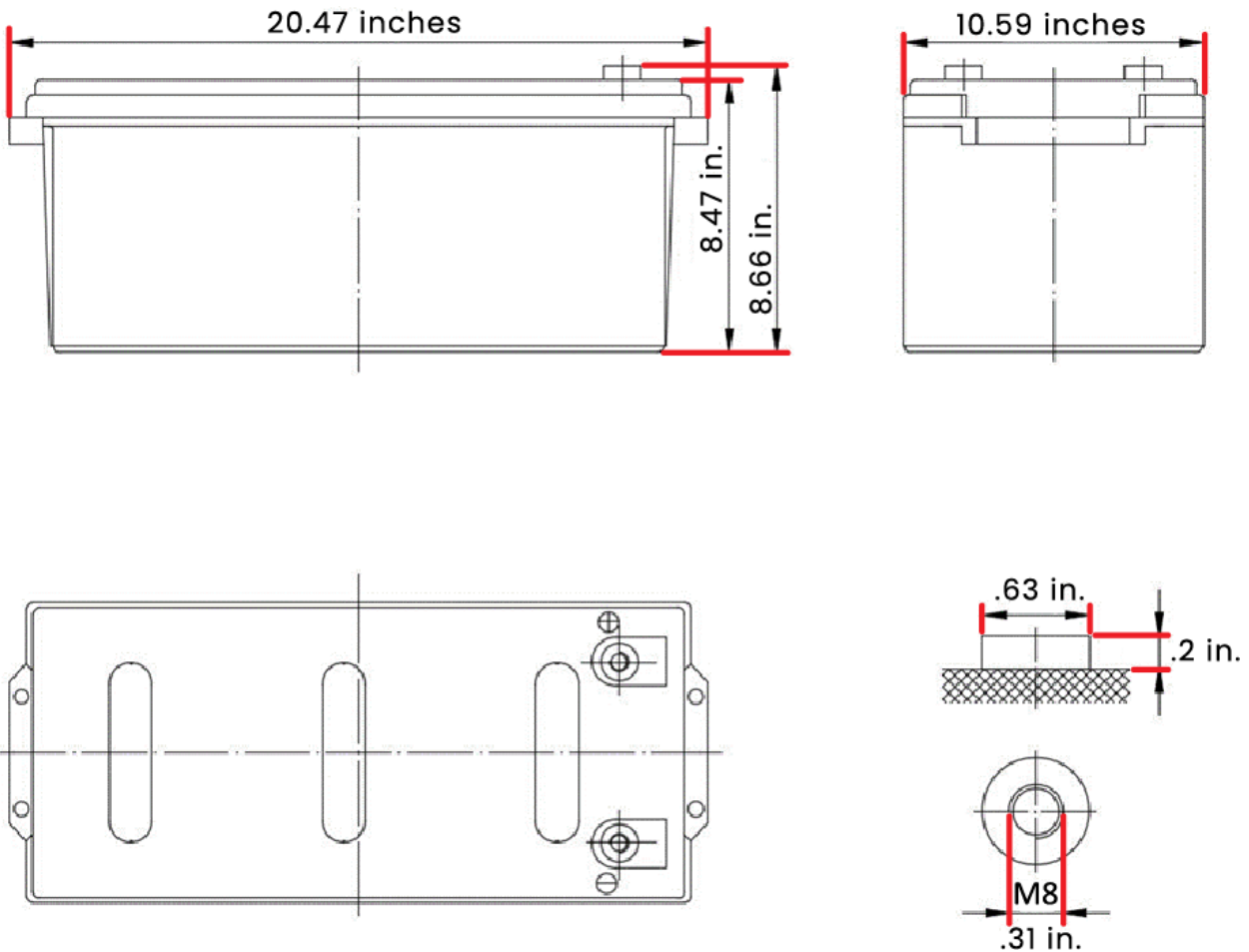

Installation

Needed Tools For Installation

The tools required may vary depending on how you choose to mount your battery. In general, you will need the following items to install your battery into an EG4 racking solution.

1. 10mm socket and ratchet
2. Phillips head screwdriver
3. Torque wrench of proper size

How to Connect Cables to the Battery Terminals

1. Identify the positive and negative terminals on your battery. These are labeled and color coded. (Red for Positive, Black for Negative)
2. Verify you have all hardware to attach the cable properly. Check to ensure the bolt insert for the terminal fully seats and can be tightened to the proper torque.
3. Connect the cables to your battery terminals by removing the terminal bolts, inserting them through the eyelet of the proper cable, and reseating the bolt into the terminal block to the correct torque.
4. DO NOT finger tighten the terminal bolts. They require a specific torque (60 in-lb/7nm) to ensure they do not loosen during operation. Failure to properly tighten the terminal bolts can result in serious damage and will void your warranty.

Battery Charging

Once you are ready to charge your batteries, you must ensure that you use the proper settings. This will ensure that you don't over-charge or damage your batteries.

1. Bulk/Absorption: 56.0V (+/- 1%)
2. Float: 54V (+/- 2%)
3. Battery Charge Temperature Range: 32°F - 113°F
4. Battery Discharge Temperature Range: -4°F - 131°F

What To Expect During a Charge Cycle

It is normal for LFP batteries that have their own internal BMS and that are wired in parallel to demonstrate a fairly wide variety of SOC readings during any given charge or discharge cycle. Variations of up to 10% are common. This is not cause for concern or indication you are getting anything less than the full capacity of your pack. This is caused by even slight variations in wiring resistance to each battery, internal resistance, temperature differences and variations in cell manufacture. Even a slight variation causes one battery to take more of the load or charge for a while. Over the duration of the discharge or charge cycle, this will balance out with the lagging battery then taking the load or charge at the other end of the cycle resulting in recovering the full listed KWH capacity of the pack. The voltage differences created as batteries diverge in SOC will eventually cause them to converge at some point in the cycle.

Introduction to the BMS

The BMS (Battery Management System) is designed to protect your battery and battery cells from a number of situations that may damage or destroy your system. This protection also helps keep your battery and the battery cells operable for a larger number of life cycles. Each EG4 battery is specifically configured to ensure the optimal performance and operation of your equipment. The EG4 Waterproof batteries are integrated with Bluetooth, check the battery by mobile APP, and support both Android and IOS.

PCB Temperature Protection

The BMS will ensure that the PCB (Printed Circuit Board) does not overheat. This is the part that houses most of the “brains” of the battery. This feature will turn off the battery if it begins to overheat.

Cell Balance Protection

Cell balance ensures that each cell is within a specific voltage range of each other. Cell balance is crucial for ensuring that your battery is operating properly for its lifespan. This is done automatically at all times.

Environmental Temperature Protection

In periods of extreme heat or cold, it may be dangerous for your battery to operate. Continued operation in these conditions can cause permanent damage to your battery, and electrical system. To ensure this does not happen, the BMS is designed to measure the temperature while it is charging/discharging, and will shut down the battery to prevent damage.

Voltage Protection

The BMS is designed to constantly monitor the voltage of each individual cell and ensure that they do not become over/undercharged.

Current Protection

The BMS is designed to constantly monitor the charge/discharge amperage, and has built in protections against exceeding specific parameters. These include built in timers that shut off quickly in the event of extremely large amperage, and delayed shut down for amperage that is only slightly above maximum. This also protects from short circuits.

EG4 BLUETOOTH APPLICATION DOWNLOAD:



SCAN TO DOWNLOAD

Download the app using the QR codes here. (You may need to enable “Allow install from unknown sources” on Android devices.)



iOS App



Android App

Battery Module Performance Curve

Charge & Discharge curve with 0.5C @ 25°C

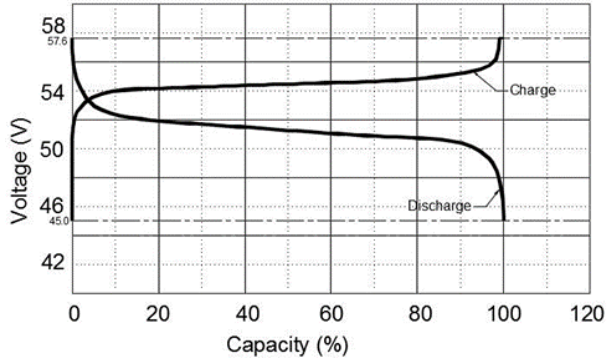

Discharge performance with different rate @ 25°C

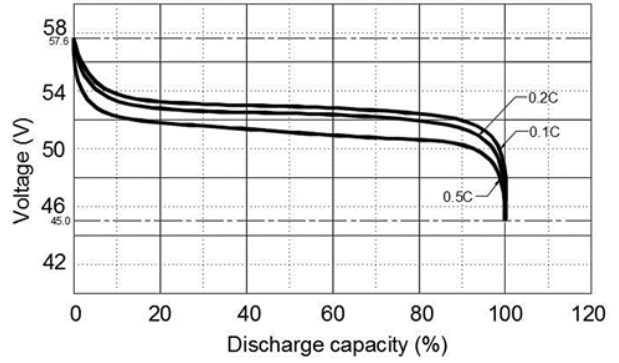

Discharge capacity with different temperature @ 0.5C

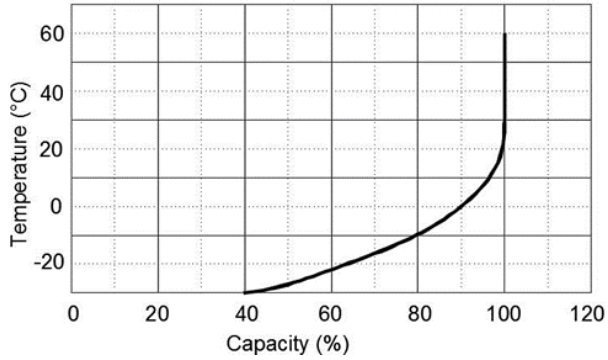

Cycle life with DOD @ 0.5C, 25°C

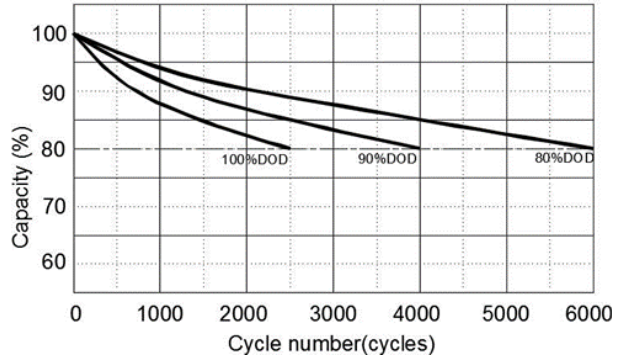

Self-discharge @ different temperature

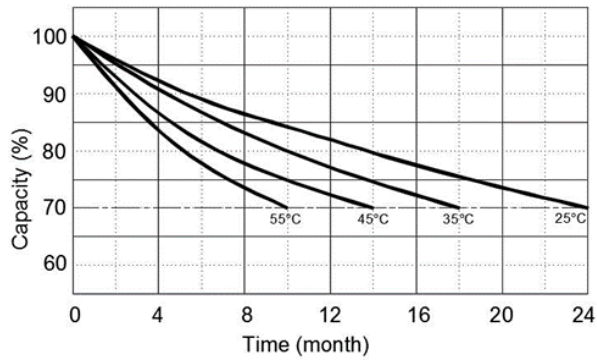

Battery Storage

How do you properly store your battery?

If you plan to store your batteries, there are a few steps you can take to ensure that they are stored safely and in a state that will ensure they are not damaged while storing them. These include a few factors as detailed below.

Battery State

The state of the battery when placed into storage will affect how long it can be stored for as well as the condition when you begin using it again. EG4 recommends that each battery is brought to a SOC (state of charge) of 100% prior to placing it in storage. Lithium iron phosphate batteries will lose a certain percentage of their total charge while in storage, depending on how long they are stored and the conditions they are stored in. Our recommendation is to ensure they are fully charged to allow them to be stored as safely and for as long as possible.

Environmental Factors

The environment you store your EG4 battery in can greatly affect the health of the battery. The temperature should remain moderate. We also suggest keeping the battery away from locations where it may get wet, or locations with extremely high humidity.

What steps should you take to maintain a healthy battery?

EG4 batteries are an advanced lithium iron phosphate battery. This means that in reality, they require very little maintenance. If used correctly by following this manual, we have designed these to be 'set it and forget it' for most of their lifespan. We do recommend connecting to the batteries periodically using the monitoring software to ensure there aren't any irregularities, and if you are placing the batteries in series without a bus-bar, to ensure you fully charge your batteries periodically. Beyond that, after initial set up you shouldn't need to do much with your batteries at all.

Battery End of Life

How should you properly recycle or dispose of your batteries?

The EG4 battery is designed to last for 15+ years when used correctly. We have worked tirelessly to ensure that our batteries will maintain a charge after thousands of cycles, and typically the battery will outlast most enclosures. However, when it does come time to retire your battery, there are a few things you must consider.

Lithium iron phosphate batteries are considered a hazardous material and should not be disposed of by simply placing them in the trash. There are a number of online websites and organizations that will accept your battery to recycle at little to no cost to you. At EG4, we understand that we are working with customers across the United States and the world. Our best recommendation is to visit your favorite search engine, and search the term "Lithium Battery Disposal Near Me". You will likely get an assortment of organizations that can safely dispose of your battery. We highly recommend calling ahead of time to ensure that the location is still open and accepting materials.

If, however, you are unable to locate a disposal location safely, we are here to help. Before dumping your battery or disposing of it incorrectly, please contact our customer service team for further assistance.

EG4 Warranty

Your warranty must be registered within the first year of purchase to remain valid. If you choose not to register your warranty, your warranty may be invalidated. This limited warranty is to the original purchaser of the product and not transferable to any other person or entity. All BMS and Cell Exchanges are covered throughout the warranty period. If a full replacement warranty is needed the warranty is prorated 1/9th per year after the first year at the current retail pricing.

Warranty Exclusions - EG4 Electronics has no obligation under this limited warranty for product subjected to the following conditions (including but not limited to):

- Damages incurred during installation or removal
- Damages caused during mishandling of product
- Inappropriate Environmental Exposure
- Damages caused by improper maintenance
- Tampering, Altering, and/or Disassembly of product
- Using product in applications other than which it was intended for by manufacturer
- Lightning, Fire, Flood, or Acts of God
- Any product whose serial number has been altered, defaced, or removed

The equipment sold by EG4 Electronics is designed to be installed only by licensed, trained, and insured solar electrical installation professionals. We strongly advise the customer to seek the assistance of such a professional to exclusively perform the implementation of any of these products, and we make no warranty of the purchaser's safety, success of equipment implementation, or compliance with local codes and regulations.

EG4 Electronics disclaims all additional warranties, expressed or implied, including but not limited to, any implied warranty with respect to the accuracy or completeness of the information they disseminate and /or fitness of the materials sold for a particular purpose. No warranty may be created or extended by sales or promotional materials on these items. Each party hereby irrevocably waives its rights to trial by jury in any Action or proceeding arising out of this agreement or the transactions relating to its subject matter. All installation advice provided by EG4 before, during, or after purchase of solar equipment is purely for the purpose of general concept education and must not replace the expertise of a licensed and trained solar specialist. The Customer agrees to full indemnification for EG4 henceforth from any legal recourse relating to and arising out of losses, direct or consequential, from the installation of the products purchased by the customer in excess of the value of the equipment purchase price.